

HUSSMANN®



DOE 2017
Energy Efficiency
Compliant

ISF and ISM Low and Medium Temperature Self Contained Island Merchandisers



IMPORTANT
Keep in store for
future reference!

Installation & Operation Manual

P/N 0515154_L
June 2018

Spanish 0531291
French 0531292

ATTENTION

Merchandiser must operate for 24 hours
before loading product!

Regularly check merchandiser temperatures.

Do not break the cold chain. Keep products
in cooler before loading into merchandiser.

These merchandisers are designed
for pre-chilled products only.



IMPORTANT
KEEP IN STORE FOR FUTURE REFERENCE
Quality that sets industry standards!

12999 St. Charles Rock Road • Bridgeton, MO 63044-2483

U.S. & Canada 1-800-922-1919 • Mexico 1-800-890-2900

www.hussmann.com

© 2018 Hussmann Corporation

TABLE OF CONTENTS

<p>ANSI Z535.5 DEFINITIONS vi</p> <p>INSTALLATION</p> <p>UL Listing 1-1</p> <p>Federal / State Regulation 1-1</p> <p>Husmann Product Control 1-1</p> <p>Shipping Damage 1-1</p> <p>Location 1-1</p> <p>Self Contained Location 1-2</p> <p>Model Description 1-3</p> <p>Unloading 1-3</p> <p>Exterior Loading 1-3</p> <p>Shipping Skid 1-3</p> <p>Merchandiser Leveling 1-4</p> <p>Serial Plate Location 1-4</p> <p>Refrigeration Unit Access 1-4</p> <p>Sealing Merchandiser to Floor 1-4</p> <p>Self-Contained Refrigeration Equipment Start Up Check List 1-5</p> <p>ELECTRICAL / REFRIGERATION</p> <p>Merchandiser Electrical Data 2-1</p> <p>Field Wiring 2-1</p> <p>Electrical Connections 2-1</p> <p>Electrical Outlet 2-1</p> <p>Refrigeration (Self Contained Models) .. 2-1</p> <p>Compressor (Self Contained). 2-2</p> <p>Waste Outlet and Water Seal 2-2</p> <p>START UP / OPERATION</p> <p>Controller Operation 3-1</p> <p>KDEPLUS Buttons 3-1</p> <p>Technical Data 3-2</p> <p>Connections 3-4</p> <p>LED 3-5</p> <p>KDEPLUS Buttons 3-6</p> <p>Setpoint: Setting and Edit Lock 3-7</p> <p>Display Probes Value 3-7</p> <p>Key-Activated Functions 3-7</p> <p>Low temp to medium temperature set-point adjustment 3-8</p>	<p>Typical Sensor Location 3-9</p> <p>Controls and Adjustments 3-10</p> <p>Start Up 3-11</p> <p>TEV Adjustment 3-11</p> <p>Load Limits 3-12</p> <p>Stocking 3-12</p> <p>Thermometer 3-12</p> <p>MAINTENANCE</p> <p>Care and Cleaning 4-1</p> <p>Removing Scratches from Bumper 4-2</p> <p>Cleaning Under Fan Plenum 4-2</p> <p>Cleaning Discharge Air Louvers 4-2</p> <p>Cleaning Stainless Steel Surfaces 4-3</p> <p>Cleaning Coils 4-3</p> <p>Cleaning Evaporation Pan 4-4</p> <p>Self-Contained Refrigeration Equipment Maintenance Check List 4-5</p> <p>SERVICE</p> <p>Replacing Fan Motors and Blades 5-1</p> <p>Replacing Nosing Anti-Sweat Heater ... 5-3</p> <p>APPENDIX</p> <p>Replacement Parts List A-1</p> <p>Plan View A-3</p> <p>Cross Section and Refrigeration Data... A-4</p> <p>Electrical Data A-5</p> <p>Shipping Weights and Amps A-6</p> <p>ISFGG-5DG (Self Contained) Wiring Diagram A-7</p> <p>ISMGG-5B (Self Contained) Wiring Diagram A-8</p> <p>ISF-GG10DG (Self Contained) Wiring Diagram A-9</p> <p>ISMGG-10B (Self Contained) Wiring Diagram A-10</p> <p>WARRANTY</p>
---	--

REVISION HISTORY

REVISION L — JUNE 2018

- 1. Removed sensor wire color, Page 3-9

REVISION K — DECEMBER 2017

- 1. Added Page 3-8; Updated Note on Page A-5

REVISION J — SEPTEMBER 2017

- 1. Page 3-1 to 3-6-Remove previous controller information
- 2. Page 3-7 -Replace picture on the page top with coil
- Replace Sensor Connections picture with Sensors
-On left bottom image replace Black with Green and Yellow with Orange-On right bottom picture select correctly the Defrost Sensor
- 3. Page 3-8-Change Temperature termination value of the ISFGG to 48 F-On first text paragraph replaced controller-Remove word knob
- 4. Page 3-9- On first paragraph replaced controller -Change Defrost Sensor color Yellow to Orange
- 5. Page A-2-Replace Safenet III table with Controller Parts IS
- 6. Page A-4 -and text -Change Defrost Termination to 48 on ISF
- 7. Pages A-7, A-8, 5-13, 5-14 - . Replaced diagrams

REVISION H — APRIL 2017

Revised Cover; 2-1 changed pan heater note in box; A-2 Added not for USA and Canada on Condensate Pan Heater; A-5- Updated values

REVISION G — OCTOBER 2014

Parameter Codes, Page 3-2
Dual Temp Label Drawing, Page 3-6
New Parts List, Page A-1 and A-2
Updated Wiring Diagrams

REVISION F — NOVEMBER 2013

Removed all remote references throughout the manual
New Sensor Drawing Page 3-7

REVISION E — OCTOBER 2013

- 1. Warning Box Page 1-2.
- 2. Checklist, Page 1-5 Checklist Page 4-5
- 3. Dual Temp Control Settings 3-6.
- 4. Revised Sensor to Control Locations.
- 5. Safe-NET PNs Page A-1.

REVISION D — AUGUST 2013

- 1. Page A-6 Appendix, deleted wiring diagram and replace with new.
- 2. Page A-7 Appendix, Please delete wiring diagram and replace with new.
- 3. Page 3-1 - 3-7 Delete logo from the control.
- 4. Last Page Remove logo marked in RED

REVISION C — AUGUST 2012

- 1. Revised Pan and Heater Part numbers, Section 5

REVISION B — OCTOBER 2010

- 1. Added self contained location drawings, page 1-2
- 2. Added Line Sizing, page 2-9
- 3. Added Koolgas and Remote Refrigeration, page 2-9
- 4. Added TEV drawing and adjustment, page 3-1
- 5. Added Cleaning Precautions, page 4-4
- 6. Added plan views and cross section, pages A-1, A-2

ORIGINAL ISSUE — MARCH 2010

ANSI Z535.5 DEFINITIONS



• **DANGER** – Indicate[s] a hazardous situation which, if not avoided, will result in death or serious injury.



• **WARNING** – Indicate[s] a hazardous situation which, if not avoided, could result in death or serious injury.



• **CAUTION** – Indicate[s] a hazardous situation which, if not avoided, could result in minor or moderate injury.

• **NOTICE** – *Not related to personal injury* – Indicates[s] situations, which if not avoided, could result in damage to equipment.

INSTALLATION

UL LISTING

These merchandisers are manufactured to meet ANSI/ UL 471 standard requirements for safety. Proper installation is required to maintain the listing.

FEDERAL / STATE REGULATION

These merchandisers at the time they are manufactured, meet all federal and state/provincial regulations. Proper installation is required to ensure these standards are maintained. Near the serial plate, each merchandiser carries a label identifying the environment for which the merchandiser was designed for use. A Type II fan speed control kit is required for each merchandiser to operate at Type II conditions.

ANSI/NSF-7 Type I – Display Refrigerator / Freezer

Intended for 75°F (24°C) / 55%RH Ambient Application

ANSI/NSF-7 Type II – Display Refrigerator / Freezer
Intended for 80°F / 55%RH Ambient Application

ANSI/NSF-7 – Display Refrigerator
Intended for Bulk Produce

HUSSMANN PRODUCT CONTROL

The serial number and shipping date of all equipment is recorded in Hussmann's files for warranty and replacement part purposes. All correspondence pertaining to warranty or parts ordering must include the serial number of each piece of equipment involved. This is to ensure the customer is provided with the correct parts.

SHIPPING DAMAGE

All equipment should be thoroughly examined for shipping damage before and during

unloading. This equipment has been carefully inspected at our factory. Any claim for loss or damage must be made to the carrier. The carrier will provide any necessary inspection reports and/or claim forms.

Apparent Loss or Damage

If there is an obvious loss or damage, it must be noted on the freight bill or express receipt and signed by the carrier's agent; otherwise, carrier may refuse claim.

Concealed Loss or Damage

When loss or damage is not apparent until after equipment is uncrated, retain all packing materials and submit a written response to the carrier for inspection within 15 days.

LOCATION

These merchandisers are designed for displaying products in air conditioned stores where temperature is maintained at or below the ANSI / NSF-7 specified level and relative humidity is maintained at or below 55%. Placing refrigerated merchandisers in direct sunlight, near hot tables or near other heat sources could impair their efficiency. Like other merchandisers, these merchandisers are sensitive to air disturbances. Air currents passing around merchandisers will seriously impair their operation. Do NOT allow air conditioning, electric fans, open doors or windows, etc. to create air currents around the merchandiser.

<p>Recommended operating ambient temperature is between 65°F (18°C) to 80°F (26.7°C). Maximum relative humidity is 55%.</p>
--

1-2 INSTALLATION

SELF CONTAINED (LOCATION)

Product should always be maintained at proper temperature. This means that from the time the product is received, through storage, preparation and display, the temperature of the product must be controlled to maximize the life of the product.

BE SURE TO POSITION SELF CONTAINED MERCHANDISERS PROPERLY.

SELF CONTAINED models have vented base panels to allow air circulation through the condensing unit.

For California Businesses:

WARNING

This product may contain chemicals known to the State of California to cause cancer, birth defects, or other reproductive harm.

This warning is the result of the California State law known as the California Safe Drinking Water and Toxic Enforcement Act of 1986, which is commonly referred to as "Proposition 65." This warning does not mean that Hussmann products will cause cancer or reproductive harm, or is in violation of any product-safety standards or requirements. As clarified by the California State government, Proposition 65 can be considered more of a 'right to know' law than a pure product safety law. When used as designed, Hussmann believes that our products are not harmful. We provide the Proposition 65 warning to stay in compliance with California State law. It is your responsibility to provide accurate Proposition 65 warning labels to your customers when necessary. For more information on Proposition 65, please visit the California State government website.

Allow for a minimum 4 in. clearance from walls, merchandisers, and any other large objects near the merchandiser's vented base panels (for self contained models). Blocking or restricting air flow will adversely affect performance and may damage the refrigeration system.

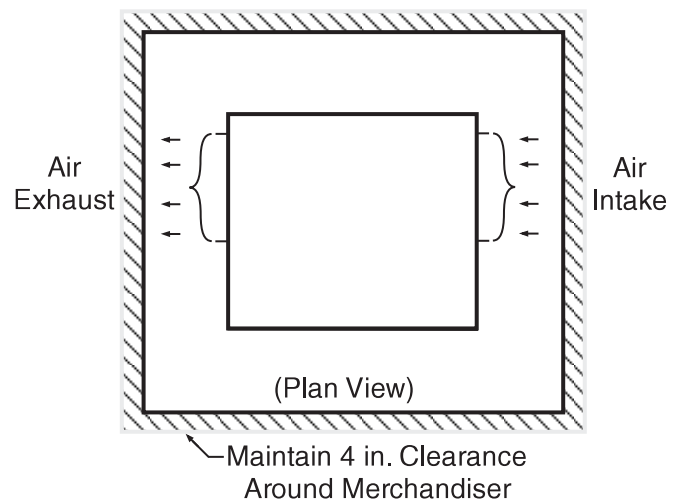
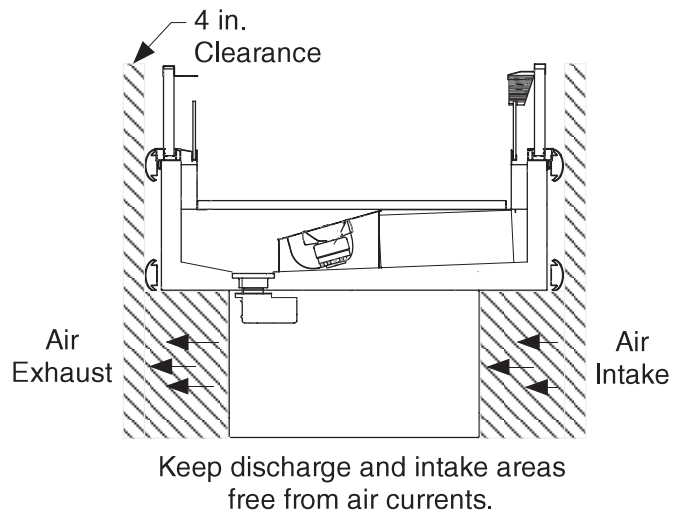

WARNING

Do NOT stand or walk on top of merchandiser. Do not store items or flammable materials atop the unit.

MODEL DESCRIPTION

The ISFGG and ISMGG models are island, spot display merchandisers. Each self contained model will have its own condensing unit, factory installed beneath the display area of the case ready for operation when electrical service is connected.

ISFGG models are designed for low temperature and dual-temperature operation: either low temperature (frozen food), or medium temperature (fresh meat, dairy and delicatessen models). ISMGG model is designed for medium temperature operation. ISFGG and ISMGG have upper glass on all four sides of the merchandiser.



CAUTION

Do not walk or put heavy objects on case.
Do not place objects atop the unit.

UNLOADING

Unloading from Trailer:

Lever Bar (also known as a Mule, Johnson Bar, J-bar, Lever Dolly, or Pry Lever)

Move the merchandiser as close as possible to its permanent location and remove all packaging. Check for damage before discarding packaging. Remove all separately packed accessories such as kits and shelves.

Improper handling may cause damage to the merchandiser when unloading. To avoid damage:

1. Do not drag the merchandiser out of the trailer. Use a Johnson bar (mule).
2. Use a forklift or dolly to remove the merchandiser from the trailer.

EXTERIOR LOADING

Do NOT walk on top of merchandisers or damage to the merchandisers and serious personal injury could occur.

MERCHANDISERS ARE NOT STRUCTURALLY DESIGNED TO SUPPORT EXTERNAL LOADING such as the weight of a person. Do not place heavy objects on the merchandiser.

SHIPPING SKID

Each merchandiser is shipped on a skid to protect the merchandiser's base, and to make positioning the case easier.

Remove the top of the crate and detach walls from each other. Lift crate from the skid. Unscrew the case from the skid. The fixture can now be lifted off the crate skid. **Lift only at base of skid!** Remove any braces and/or skids attached (blanket wrapped merchandiser may have skids).

DO NOT LAY MERCHANDISER OVER ON THE FLOOR TO REMOVE SKID.

Once the skid is removed, the merchandiser must be lifted —NOT PUSHED— to reposition. To remove the skid, remove screws attaching skid to the merchandiser.

Check floor where cases are to be set to see if it is a level area. Determine the highest part of the floor.



WARNING

Do NOT remove shipping crate until the merchandiser is positioned for installation.

1-4 INSTALLATION

MERCHANDISER LEVELING

BE SURE TO POSITION MERCHANDISERS PROPERLY. Level the merchandiser by all four corners. Merchandiser(s) must be installed level to ensure proper operation of the refrigeration system, and to ensure proper drainage of defrost water.

SERIAL PLATE LOCATION

The serial plate is located on the inside of the merchandiser's display area.

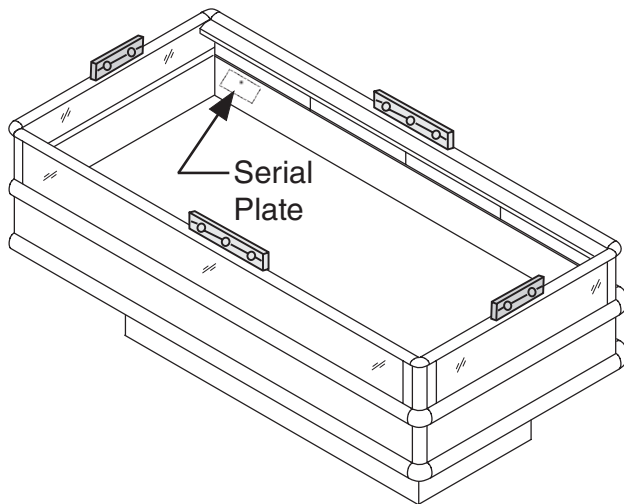

REFRIGERATION UNIT ACCESS

The lower front panel may be removed by lifting the panel straight upward and over the tabs on which it is hanging. In a self contained merchandiser, two screws will have to be removed from either end of the panel. The panel is installed by reversing the above procedure. Ensure lower front panel is flat against the floor when installed to prevent air circulation problems for self contained merchandisers.

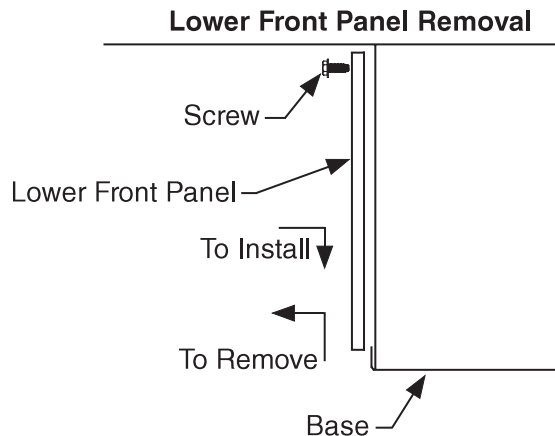

SEALING MERCHANDISER TO FLOOR

If required by local sanitary codes, or if the customer desires, merchandisers may be sealed to the floor using a vinyl cove base trim. The size needed will depend on how much variation there is in the floor, from one end of the merchandiser to the other. Sealing of the lower front and rear panels on self contained models may hamper their removal for servicing or maintenance of the condensing unit.

NOTE: Do not allow trim to cover any intake or discharge grilles located in the lower front panel.

Hussmann Self-Contained Refrigeration Equipment Start Up Check List

Please note that failure to follow this start-up document may void your factory warranty

Step	Startup Activity	Check
1	Locate, read and maintain install/operation manual in a safe place for future reference.	<input type="checkbox"/>
2	Examine unit. Confirm there is NO damage or concealed damage.	<input type="checkbox"/>
3	Level the unit, side to side and front to rear.	<input type="checkbox"/>
4	Remove all shipping brackets/compressor straps/bolts etc.	<input type="checkbox"/>
5	Unit must be run on a dedicated electrical circuit without the use of an extension cord.	<input type="checkbox"/>
6	Ensure that the proper electrical requirements for the equipment are supplied.	<input type="checkbox"/>
7	Verify field electrical connections are tight.	<input type="checkbox"/>
8	Verify all electrical wiring is secured and clear of any sharp edges or hot lines.	<input type="checkbox"/>
9	Verify the condensate drain line is properly trapped and pitched.	<input type="checkbox"/>
10	Verify all required clearances on the sides and back of unit.	<input type="checkbox"/>
11	Verify there are no air disturbances external to the unit. Heat and air registers, fans, and doors etc.	<input type="checkbox"/>
Advise owner/operator that merchandiser must operate at temperature for 24 hrs prior to loading with product.		

Form HSCW01 Rev. 30MAY12 P/N 0525209_B

LEGAL DISCLAIMER:

Hussmann shall not be liable for any repair or replacements made without the written consent of Hussmann, or when the product is installed or operated in a manner contrary to the printed instructions covering installation and service which accompanied such product.

1-6 INSTALLATION

NOTES:

ELECTRICAL / REFRIGERATION

MERCHANDISER ELECTRICAL DATA

Refer to the technical data sheets and merchandiser serial plate for electrical information.

FIELD WIRING

Field wiring must be sized for component amperes stamped on the serial plate. Actual ampere draw may be less than specified.

ALWAYS CHECK THE SERIAL PLATE FOR COMPONENT AMPERES

ELECTRICAL CONNECTIONS

All wiring must be in compliance with NEC and local codes.

ELECTRICAL OUTLET:

Before the merchandiser is connected to any wall circuit, use a voltmeter to check that the outlet is at 100% of the rated voltage. The wall circuit must be dedicated for the merchandiser. Failure to do so voids the warranty. Do not use an extension cord. Never plug in more than one merchandiser per electrical circuit.

- Always use a dedicated circuit with the amperage stated on the unit.
- Plug into an outlet designed for the plug.
- Do not overload the circuit
- Do not use long or thin extension cords. Never use adapters.
- If in doubt, call an electrician.

Self-contained models have factory-installed power cords attached at the electrical box.

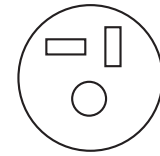

NEMA 6-20P
Receptacle
ISF

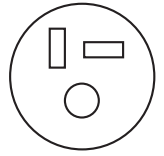

NEMA 5-20P
Receptacle
ISM

IMPORTANT:

For USA/Canada, a HI-Humidity Condensate Pan Kit is provided with ISFGG-5D/G or a 10D/G, a separate dedicated circuit is required- 230V, 15 Amp circuit and a NEMA 6-15R receptacle. ISFGG-10D/G requires 2 circuits.

For USA/Canada, a HI-Humidity Condensate Pan Kit is provided with ISMGG-5B or a 10B, a separate dedicated circuit is required- 120V, 15 Amp circuit and a NEMA 5-15R receptacle. ISMGG-10B requires 2 circuits.

NOTE:

This extra circuit is only for the Hi-Humidity Condensate Pan Kit. It is not part of the case circuit.

REFRIGERATION (Self Contained Models)

Each self contained model is equipped with its own condensing unit and control panel located beneath the display area. The correct type of refrigerant will be stamped on each merchandiser's serial plate. The merchandiser refrigeration piping is leak tested. The unit is charged with refrigerant, and shipped from the factory with all service valves open.

**COMPRESSOR
(Self Contained)**

The ISF compressor is mounted on vibration springs. The compressor is banded down during shipment. **This band MUST be cut and removed to allow the compressor to float freely once placed into operation.** Failure to cut compressor shipment band may result in excessive noise or system damage.

WASTE OUTLET AND WATER SEAL

The condensate water outlet is located in the center of the merchandiser. The outlet has a factory installed, external water seal.

For self contained models, this water seal drains into the condensate evaporator pan located beneath the merchandiser.

NOTE: All lower base panels must be in place when the refrigerator is operating. If not, airflow from the condenser will be directed over the evaporator pan and defrost water in the pan may overflow.



WARNING

Product will be degraded and may spoil if allowed to sit in a non-refrigerated area.



WARNING

Refrigeration lines are under pressure. Refrigerant must be recovered before attempting any connection or repair.



WARNING

— LOCK OUT / TAG OUT —

To avoid serious injury or death from electrical shock, always disconnect the electrical power at the main disconnect when servicing or replacing any electrical component. This includes, but is not limited to, such items as doors, lights, fans, heaters, and thermostats.



WARNING

**Merchandiser must be grounded.
Do not remove the power supply cord ground.**



CAUTION

Risk of Electric Shock. If cord or plug becomes damaged, replace only with a cord and plug of the same type.

START UP / OPERATION

CONTROLLER OPERATION

The electronic controller is located in the cassette compartment. The controller comes factory set, and is ready for use. The front grille must be removed in order to access this control. When removing the grille for this operation or for condenser cleaning, care must be taken not to damage the display interface cable. It may be unplugged during this task.

1. Plug the merchandiser plug into its receptacle.
 - a. The controller display will illuminate.
 - b. The interior light will illuminate.
2. After the control preprogrammed time delay of up to 6 minutes, the compressor and evaporator fan(s) will start if the control is calling for cooling.
3. The control will cycle the compressor but may also cycle evaporator fan(s) on and off determined by the Set-Point and Differential temperatures.
 - a. The Set-Point is the adjustable preprogrammed temperature.
 - b. The Differential is the non-adjustable pre programmed temperature.
 - c. The Control is designed to read and display a cabinet temperature not a product temperature.

This cabinet temperature may reflect the refrigeration cycle of the Set-Point and it's Differential. The most accurate temperature on a cabinets operation is to verify the product temperature.

Taking as an example a VRL case, freezer, If the Set-Point is -12°F and the Differential is 9°F . (Set-Point) $-12^{\circ}\text{F} + 9$ (Differential) = -3°F . The compressor and evaporator fan(s) will cycle off -12°F and back on at -3°F .

Main Features:

- Panel-mounted
- Energy saving algorithms and optimised defrost control
- 8 preloaded applications
- Defrost at single / double evaporator
- Frame Heater
- Local network auto-configuration
- Direct load connection (up to 2 HP)
- Supply voltage control LVD
- Presence of an open collector output



KDEPLUS BUTTONS

The KDEPlus keyboard has 4 keys, as shown in the illustration:



Key Functions:

- 2 ON/OFF regulators for HOT/COLD
- Single defrost and double evaporator
(heatings, modulated heaters, reverse cycle, hot gas)
- Evaporator fans and condenser fans
- Frame Heater
- AUX
- Light
- Door switch
- ON /OFF
- Deep cooling cycle
- Day / Night
- Diagnostics
- “Easy Map” programming
- Programmable inputs/outputs
- LINK2 local area network
- RS485 communication protocol: Modbus
- Compatible with Device Manager (DM)
- Compatible with Unicard and Multi-function key

TECHNICAL DATA

Classification:	electronic automatic control (not safety) device for incorporation
Mounting:	panel mounting
Type of action:	1.B
Pollution class:	2
Material class:	IIIa
Overvoltage category:	II
Nominal pulse voltage:	2500V
Temperature:	Use: -5 ... +55°C - Storage: -30 ... +85°C
Power supply:	SMPS 100-240Va ±10% 50/60 Hz
Power consumption:	5.5W max
Fire resistance category:	D
Software class:	A
RTC battery life:	In absence of external power, the clock battery will last 3 years.

FURTHER INFORMATION

INPUT CHARACTERISTICS

Measurement range:	NTC: -50.0°C ... +110°C; PTC: -55.0°C ... +150°C; PT1000: -60.0°C ... +150°C (on 3-digit display with +/- sign)
Accuracy:	±1.0° for temperatures below -30°C ±0.5° for temperatures between -30°C and +25°C ±1.0° for temperatures above +25°C
Resolution:	1 or 0.1°C
Buzzer:	NO
Analogue/Digital Inputs:	5 configurable NTC/PTC/PT1000/DI inputs 1 multi-function, voltage-free digital input (D.I.)

OUTPUT CHARACTERISTICS

Digital Outputs:	OUT1: 1 SPST relay: 2HP max 240V~ OUT2: 1 SPDT relay: 1HP max 250V~ OUT3: 1 SPDT relay: 8(4)A max 250V~ OUT4: 1 SPST relay: 8(4)A max 250V~
OC (Open Collector) Output:	OC: 1 multifunctional output: 12V= 20mA

MECHANICAL CHARACTERISTICS

Dimensions:	121x92 mm
Terminals:	faston and screw for wires with cross-section of 2.5mm ²
Connectors:	TTL for Unicard / Device Manager connection (via DMI)
Humidity:	Usage / Storage: 10...90% RH (non-condensing)

REGULATIONS

Electromagnetic compatibility:	The device complies with Directive 2004/108/EC
Safety:	The device complies with Directive 2006/95/EC
Food Safety:	The device complies with standard EN13485 as follows: <ul style="list-style-type: none"> • Suitable for storage. • Application: air. • Climate range A • measurement class 1 in the range from -25°C to 15°C (*) <p>(* with Eliwell probes only)</p>

NOTE: The technical specifications stated in this document regarding measurement (range, accuracy, resolution, etc.) refer to the instrument alone and not to any accessories provided, such as the probes. This means, for example, that the error introduced by the probe must be added to the error of the instrument.

CONNECTIONS

TERMINALS

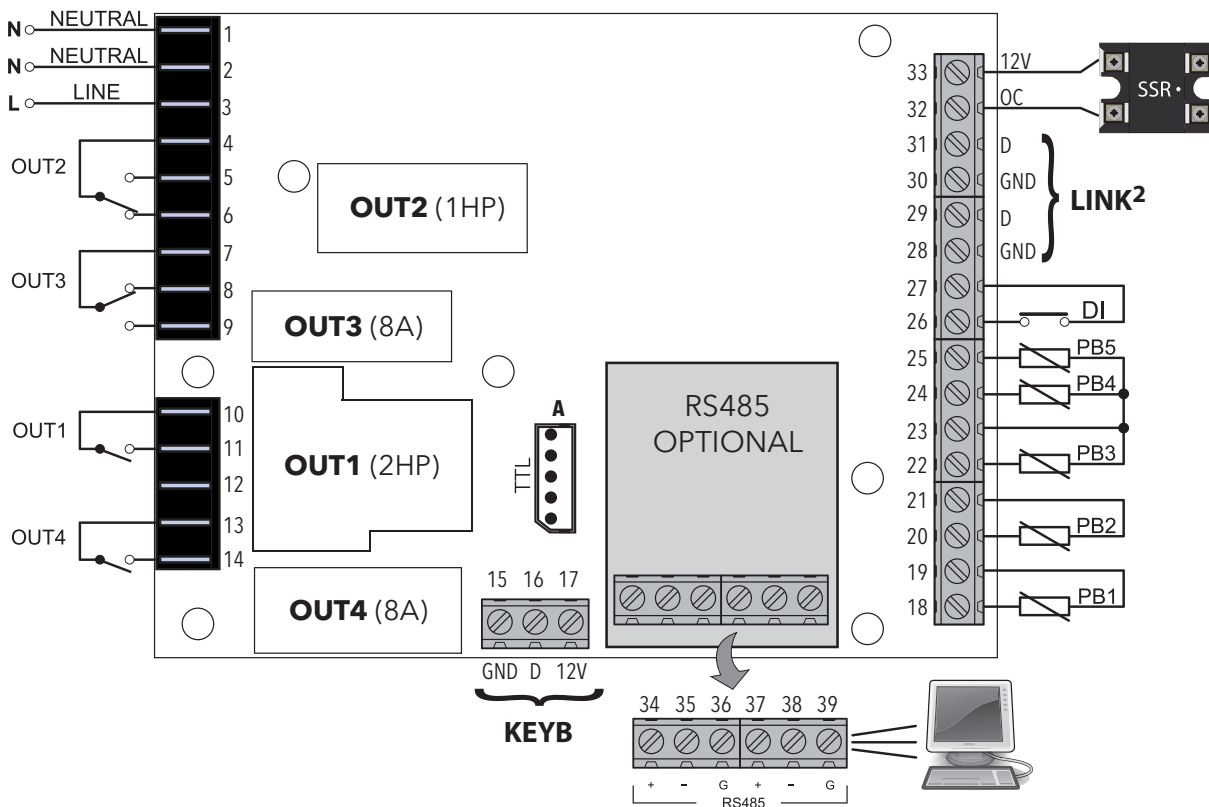

* **N.B.:** analogue inputs PB1...PB5 can also be configured as Digital Inputs DI.

TERMINALS		
1-2	NEUTRAL. These are power supply terminals.	15-16-17 Connection to KDEPlus or KDWPlus external keyboard or ECPlus echo module.
3	LINE. These are power supply terminals.	19-18 PB1 probe connection.
4	OUT2 Shared Terminal	21-20 PB2 probe connection.
5	N.O. OUT2	23-22 PB3 probe connection.
6	N.C. OUT2	23-24 PB4 probe connection.
7	OUT3 Shared Terminal	23-25 PB5 probe connection.
8	N.C. OUT3	27-26 Digital input (DI).
9	N.O. OUT3	28-29 LINK ² . Connection 1 - local area network.
10	OUT1 Shared Terminal	30-31 LINK ² . Connection 2 - local area network.
11	N.O. OUT1	32-33 Open Collector Output (OC).
12	Not Used	A TTL Unicard/DMI/Multi Function Key connection
13	OUT4 Shared Terminal	34-35-36 RS485. Connection 1 - Supervision Gateway.
14	N.O. OUT4	37-38-39 RS485. Connection 2 - Supervision Gateway.

LED

RTN400 family controllers will also function even if a keyboard has not been connected.

With **KDEPlus** or **KDWPlus** keyboards (which are the same and guarantee the same functions), the display will be as follows:

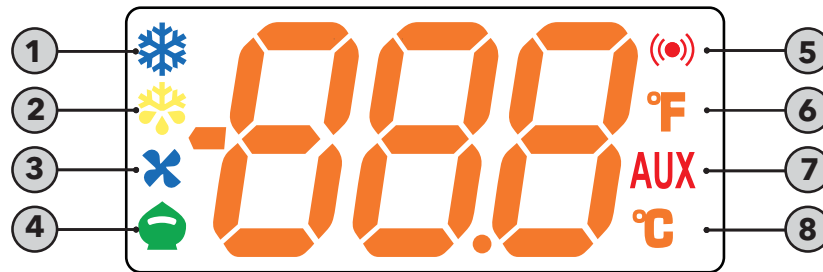

Meaning of LEDs:

No	Icon	LED	Operation	Meaning
1		Compressor	Permanently on	compressor on
			Blinking	Delay, protection or start-up blocked
			OFF	otherwise
2		Defrost	Permanently on	Defrost active
			Blinking	Activated manually or from Digital Input
			OFF	otherwise
3		Fans	Permanently on	Fans active
			OFF	otherwise
4		Reduced SET / Economy	Permanently on	Energy Saving active
			Blinking	Reduced setpoint active
			OFF	otherwise
5		Alarm	Permanently on	alarm active
			Blinking	Alarm acknowledged
			OFF	otherwise
6		°F readout	Permanently on	°F setting (dro = 1)
			OFF	otherwise
7		AUX	Permanently on	Aux output active and/or light on
			Blinking	Deep cooling on
			OFF	otherwise
8		°C readout	Permanently on	°C setting (dro = 0)
			OFF	otherwise

N.B.: When the instrument is powered on it performs a lamp test, during which time the display and LEDs will flash for several seconds to check that they all function correctly.

KDEPLUS BUTTONS

The **KDEPlus** keyboard has 4 keys, as shown in the illustration:

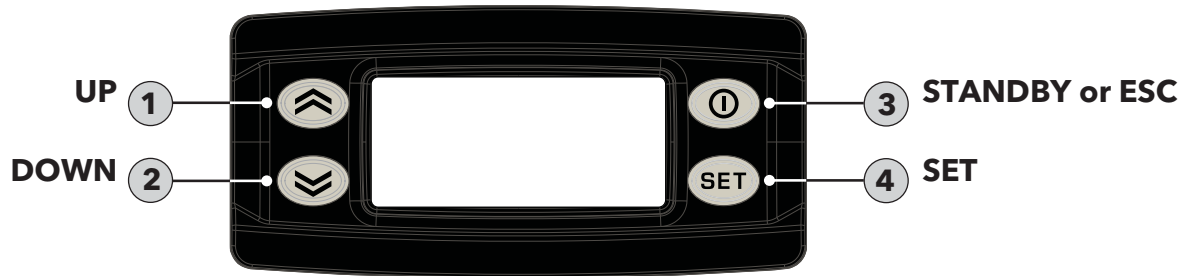





Each key has a different function depending on whether it is:

- Pressed and released
- Pressed for at least 5 seconds
- Pressed and held at start-up
- Pressed in combination with another key.

KEYS

The following table summarizes the function of each key:

No	Key	Action		
		Pressed and released	Press for at least 5 secs	Start-up
1		<ul style="list-style-type: none"> • Scrolls through menu items • Decreases values 	Activates the Manual Defrost function (from outside menus).	---
2		<ul style="list-style-type: none"> • Scrolls through menu items • Decreases values 	Function can be configured by the user (from outside menus). (see parameter H32)	---
3		<ul style="list-style-type: none"> • Returns to the previous menu level • Confirms parameter value 	Activates the Stand-by function (from outside menus).	---
4		<ul style="list-style-type: none"> • Displays any alarms (if active) • Opens Machine Status menu • Confirms commands 	Opens the Programming Menu (User and Installer parameters)	When pressed during start-up it enables the user to select the application to be loaded.

SETPOINT: SETTING AND EDIT LOCK

To display the Setpoint value, press the **set** key to enter the "Machine Status" menu, then press the **set** key again when the "SEt" label is displayed.

The Setpoint value appears on the display. To change the Setpoint value, press the **UP** and **DOWN** keys within 15 seconds. Press **set** to confirm the modification.

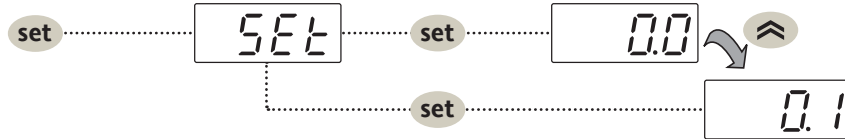

It is possible to disable the keypad on this device.

The keypad can be locked by programming the "LOC" parameter appropriately.

With the keypad locked, you can still access the "Machine Status" menu by pressing **set** to display the Setpoint, but you cannot edit it. To disable the keypad lock, repeat the locking procedure.

DISPLAY PROBES VALUE

To display the value read by probes connected to the device, press the **set** key and enter the "Machine Status" menu, then press the key again when one of the probe-related labels "Pb1...Pb5" press the **set** key again. The value measured by the associated probe will appear on the display.

NOTE: The displayed value is read-only and cannot be modified.

KDEPLUS BUTTONS

The KDEPlus keyboard has 4 keys, as shown in the illustration:



KEY-ACTIVATED FUNCTIONS

All models have the **UP** key set to enable the "Manual Defrost" function.

The DOWN and ESC keys can also be set to activate any other function required by the user.

The parameters for configuring the two keys are:

- **H11** = DOWN key configuration
- **H33** = ESC key configuration

The values that can be set apply to both keys and the functions that can be activated are:

H32/H33 value	Function to enable
0	disabled
1	defrost
2	reduced set
3	Light
4	Energy saving
5	AUX
6	Stand-by
7	Deep cooling cycle
8	Start/end defrost

LOW TEMP TO MEDIUM TEMPERATURE SET-POINT ADJUSTMENT

Apply to ISF + Dual Temp kit

KDEPLUS BUTTONS

The KDEplus keyboard has 4 keys, as shown in the illustration:



This case is pre-programmed with the low temperature set-point. Follow the steps below to convert the case to medium temperature operation.

1. To display the Setpoint value, press the **SET** key to enter the “Machine Status” menu, then press the **SET** key again when the “SEt” label is displayed.
ISF Setpoint is **-33°F** (Low Temp Setpoint)
2. To change the Setpoint value to medium temp, press the **UP** or **DOWN** keys within 15 seconds, and change it to **14°F**.
3. Press **SET** to confirm the modification.

No other setpoint changes are required. To convert back to low temp operation, simply change the setpoint back to -33F

TYPICAL SENSOR LOCATION

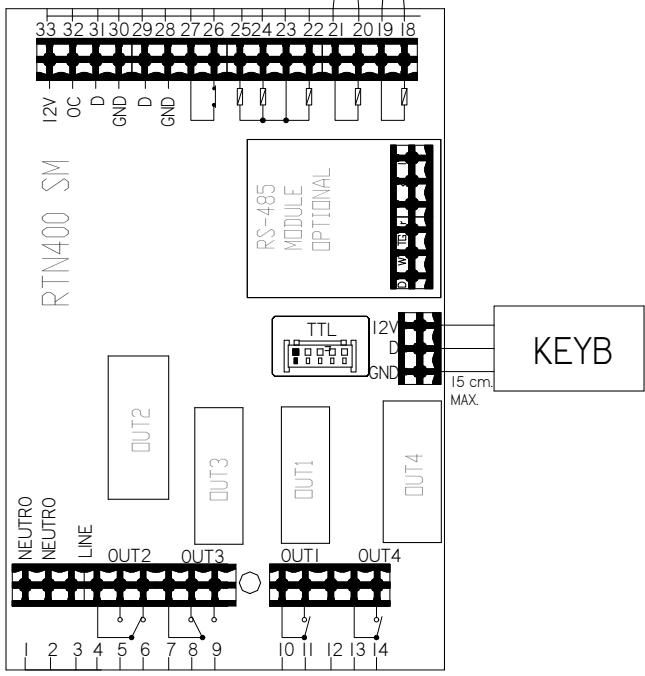
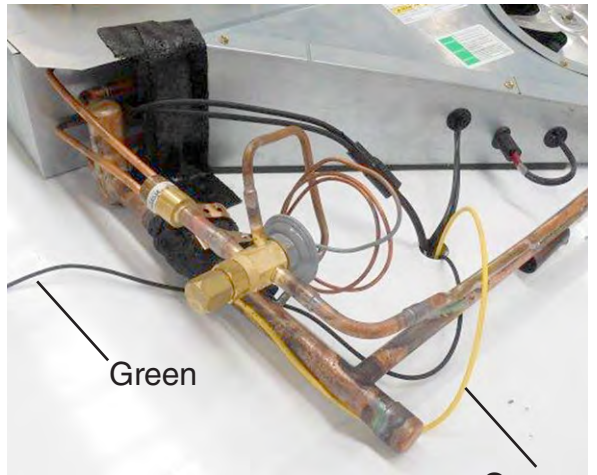
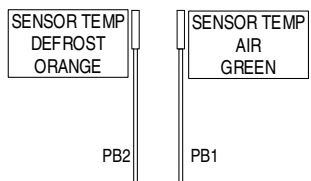
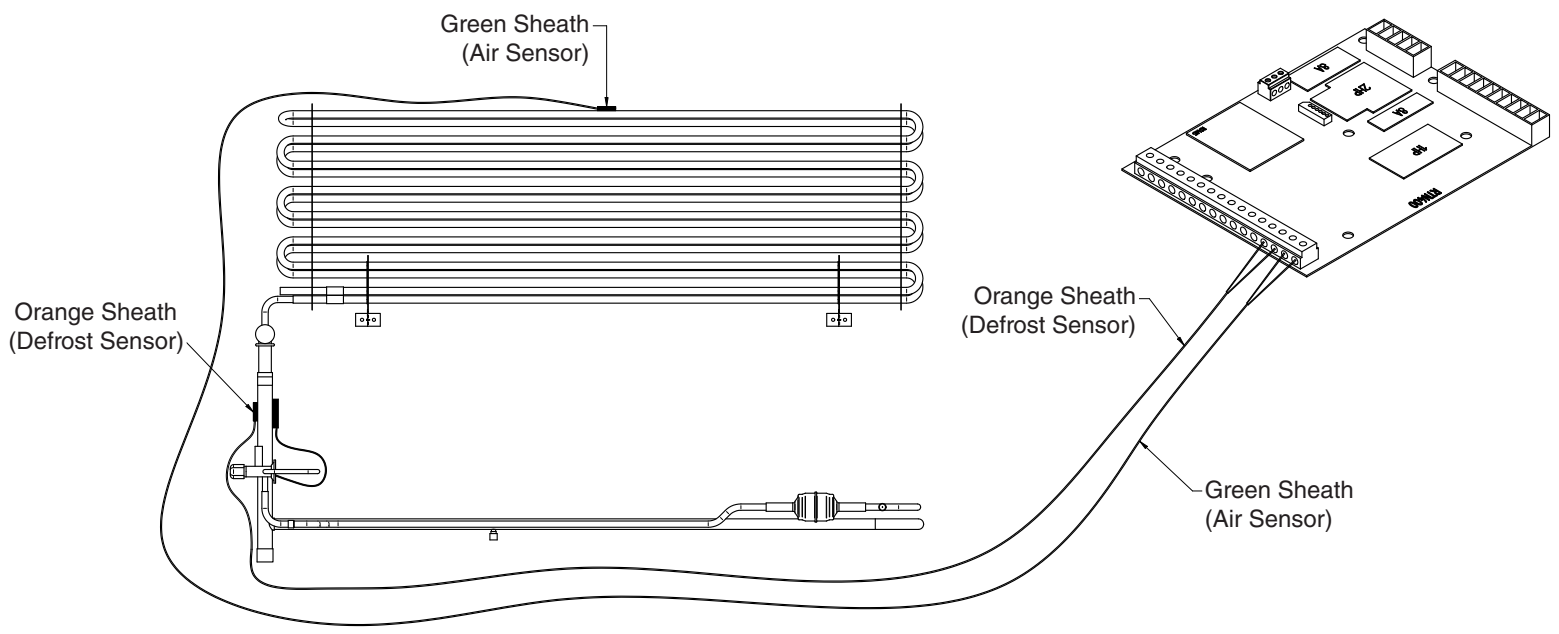

Defrost Termination Sensor

CONTROLS and ADJUSTMENTS						
Refrigeration Controls			Defrost Controls			
Model	Product Application	Discharge Air Temperature	Defrost Frequency (per day)	Type of Defrost	Temp. Termination	Failsafe Time (Minutes)
ISFGG and Dual Temp Self Contained	Low Temp. (Frozen Food)	-14° F	4	Electric	48° F	50
	Medium Temp. (Dairy, Deli)	24° F	4	Electric		
ISMGG Self Contained	Medium Temp. (Dairy, Deli)	24° F	2	Off Time	48° F	50

1. The Controller controls refrigeration temperature. This is factory installed in the control panel. Adjust this control to maintain the discharge air temperature shown. Measure discharge air temperatures at the center of the discharge louver.

Defrosts are time initiated and temperature terminated for self contained. The defrost setting is factory set as shown above.

To ensure a thorough defrost, defrost must be terminated by the temperature termination setting — not by time.

START UP

Follow the start up procedures as detailed in Section 3 of this manual. Each self contained merchandiser has its own evaporator coil and a pre-set thermostatic expansion valve (TEV). The TEV has been factory set at design conditions to provide the recommended performance.

The crankcase pressure regulating (CPR) refrigeration valve is factory set and requires no adjustment.

TEV Adjustment

Expansion valves may be adjusted to fully feed the evaporator. Before attempting to adjust valves, make sure the evaporator is clear or only lightly covered with frost, and the merchandiser is within 10°F of its expected operating temperature.

Adjust the valve as Follows:

- a. Attach a probe to the suction line near the expansion valve bulb.
- b. Obtain a pressure reading from the factory installed Schraeder valve. Convert the pressure reading to a saturated temperature for the refrigerant.

Temperature (b) minus Temperature (a) is the superheat. The valve should be adjusted so that the greatest difference between the two temperatures is 3°F to 5° F.

Make adjustments of no more than 1/2 turn of the valve stem at a time and wait for at least 15 minutes before rechecking the probe temperature and making further adjustments.



...ATTENTION
INSTALLER

COMPRESSOR

ISF self contained merchandiser has a compressor that is banded down for shipment. **This band MUST be cut and removed to allow the compressor to float freely once placed into operation.**

NOTE: Failure to cut compressor shipment band may result in excessive noise or system damage, which is not covered by warranty.

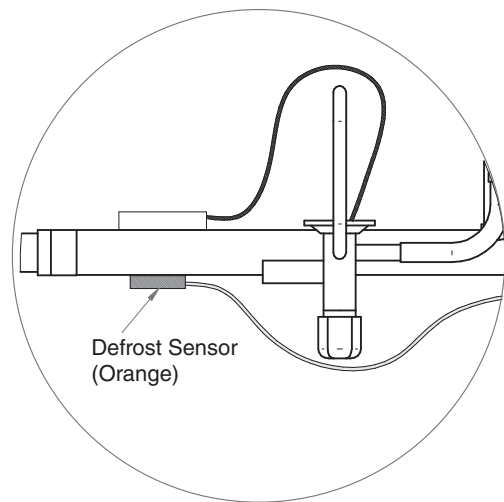

LOAD LIMITS

Each merchandiser has a load limit decal. Shelf life of perishables will be short if load limit is violated.

AT NO TIME SHOULD MERCHANDISERS BE STOCKED BEYOND THE LOAD LIMITS INDICATED.

DO NOT BLOCK AIR LOUVERS.



STOCKING

Product should NOT be placed inside the merchandisers until merchandisers are at proper operating temperature.

Allow merchandiser 24 hours to operate before loading product.

Proper rotation of product during stocking is necessary to prevent product loss. Always bring the oldest product to the top and set the newest to the bottom.

AIR DISCHARGE AND RETURN FLUES MUST REMAIN OPEN AND FREE OF OBSTRUCTION AT ALL TIMES to provide proper refrigeration and air curtain performance. Do not allow product, packages, signs, etc. to block these grilles. Do not use non-approved shelving, baskets, display racks, or any accessory that could hamper air curtain performance.

Do not allow product to be placed outside of the designated load limits in the illustration.

THERMOMETER

ISF models have a 1 in. thermometer. The thermometer is located at the top, interior of the merchandiser.

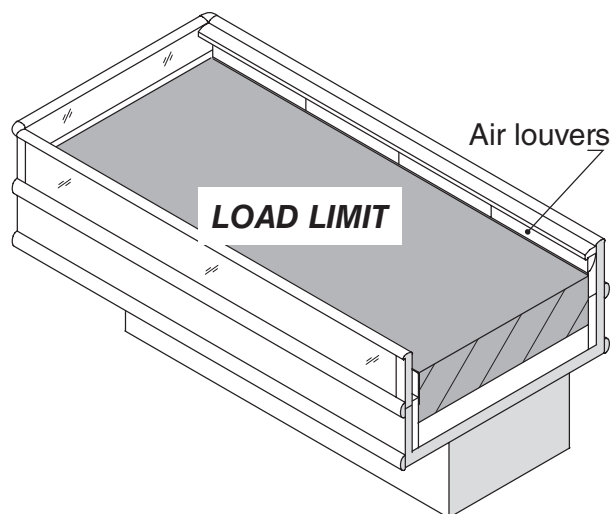

MAINTENANCE

CARE AND CLEANING

Long life and satisfactory performance of any equipment is dependent upon the care it receives. To ensure long life, proper sanitation and minimum maintenance costs, these merchandisers should be thoroughly cleaned, all debris removed and the interiors washed down, weekly.

Exterior Surfaces

The exterior surfaces must be cleaned with a mild detergent and warm water to protect and maintain their attractive finish. **NEVER USE ABRASIVE CLEANSERS OR SCOURING PADS.**

Interior Surfaces

The interior surfaces may be cleaned with most domestic detergents, ammonia based cleaners and sanitizing solutions with no harm to the surface. Self contained models empty into a limited capacity evaporation pan, which will overflow if excess water is used in cleaning.

Do NOT Use:

- Abrasive cleansers and scouring pads, as these will mar the finish.
- Coarse paper towels on coated glass.
- Ammonia-based cleaners on acrylic parts.
- Solvent, oil or acidic based cleaners on any interior surfaces.
- Do not use high pressure water hoses.

Do:

- Remove the product and all loose debris to avoid clogging the waste outlet.
 - Store product in a refrigerated area such as a cooler. Remove only as much product as can be taken to the cooler in a timely manner.
 - **Disconnect electrical power before cleaning.**
 - Thoroughly clean all surfaces with soap and hot water. **DO NOT USE STEAM OR HIGH WATER PRESSURE HOSES TO WASH THE INTERIOR. THESE WILL DESTROY THE MERCHANDISERS' SEALING CAUSING LEAKS AND POOR PERFORMANCE.**
 - Lift hinged fan plenum for cleaning. Hook chain in rear panel to secure plenum during cleaning. **BE SURE TO REPOSITION THE FAN PLENUM AFTER CLEANING MERCHANDISER.**
 - Take care to minimize direct contact between fan motors and cleaning or rinse water.
 - Do NOT flood merchandiser with water. **NEVER INTRODUCE WATER FASTER THAN THE WASTE OUTLET CAN REMOVE IT.**
- SELF CONTAINED MODELS EMPTY INTO AN EVAPORATION PAN THAT WILL OVERFLOW IF TOO MUCH WATER IS INTRODUCED DURING CLEANING.**
- Allow merchandisers to dry before resuming operation.
 - After cleaning is completed, turn on power to the merchandiser.

 **WARNING**

Product will be degraded and may spoil if allowed to sit in a non-refrigerated area.

 **WARNING**

Do NOT allow cleaning agent or cloth to contact food product.

WARNING

Do NOT use HOT water on Cold glass Surfaces. This can cause the glass to shatter and could result in personal injury. Allow glass fronts, to warm before applying hot water.

REMOVING SCRATCHES FROM BUMPER

Most scratches and dings can be removed using the following procedure.

1. Use steel wool to smooth out the surface area of the bumper.
2. Clean area.
3. Apply vinyl or car wax and polish surface for a smooth glossy finish.

CLEANING UNDER FAN PLENUM

To facilitate cleaning, the fan plenum is hinged.

After cleaning be sure the plenum is properly lowered into position OR PRODUCT LOSS WILL RESULT due to improper refrigeration.

WARNING

— LOCK OUT / TAG OUT —

To avoid serious injury or death from electrical shock, always disconnect the electrical power at the main disconnect when servicing or replacing any electrical component. This includes, but is not limited to, such items as doors, lights, fans, heaters, and thermostats.

WARNING

SHUT FANS OFF DURING CLEANING PROCESS.

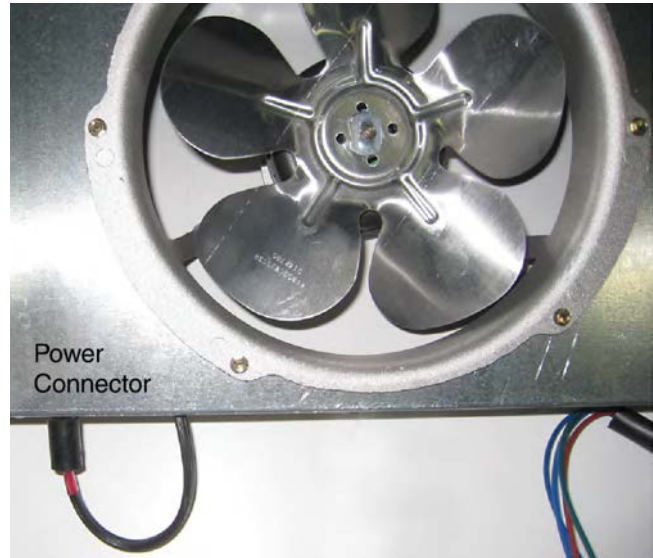

CLEANING DISCHARGE AIR LOUVERS

Discharge air louvers should be cleaned every six months. Dirty louvers will cause merchandisers to perform poorly. The louvers may be cleaned with a vacuum cleaner. Soap and water may be used if all water is removed from the louvers cells before replacing. Be careful not to damage the louvers.

1. Using a flat object such as a screw driver, compress the honeycomb and remove it from its retainer.
2. Clean and dry the air louvers.
3. After cleaning, replace in reverse order. Damaged louvers must be replaced.

 <h2 style="margin: 0;">CAUTION</h2>
<p>DO NOT FLOOD!</p> <p>Use only enough water necessary to clean surface. Water must not drip down the case!</p> <p>Never use ammonia based cleansers, abrasive cleansers, or scouring pads.</p>

CLEANING STAINLESS STEEL SURFACES

Use non-abrasive cleaning materials, and always polish with grain of the steel. Use warm water or add a mild detergent to the water and apply with a cloth. Always wipe rails dry after wetting.

Use alkaline chlorinated or non-chlorine containing cleaners such as window cleaners and mild detergents. Do not use cleaners containing salts as this may cause pitting and rusting of the stainless steel finish. Do not use bleach.

CLEANING COILS

Condenser coils should be cleaned at least once per month. Additional cleaning may be needed depending on the operational environment. A dirty condenser blocks normal airflow through the coils.

Airflow blockage increases energy consumption and reduces the merchandiser's ability to maintain operating temperature.

To clean the coils, use a vacuum cleaner with a wand attachment and a soft (non-metallic) brush to remove dirt and debris. Do not bend coil fins. Always wear gloves and protective eye wear when cleaning near sharp coil fins and dust particles.

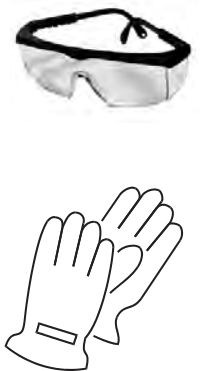

NEVER USE SHARP OBJECTS AROUND COILS. Use a soft brush or vacuum brush to clean debris from coils. *Do not puncture coils!* Do not bend fins. Contact an authorized service technician if a coil is punctured, cracked, or otherwise damaged.

ICE in or on the coil indicates the refrigeration and defrost cycle is not operating properly. Contact an authorized service technician to determine the cause of icing, and to make adjustments as necessary. To maintain product integrity, move all product to a cooler until the unit has returned to normal operating temperatures.



CAUTION

Evaporation Pan is Hot!
and poses risk of bodily injury – Always Wear gloves and protective eye wear when servicing. Turn off evaporation pan heater, and allow pan to cool.

CLEANING EVAPORATION PAN (SELF CONTAINED ONLY)

The condensate water outlet for self contained models empties into a limited capacity evaporation pan.

Debris or dirt accumulation inside the condensate evaporation pan or on the heater coil will reduce the pan's evaporation capacity and cause premature heater failure. The evaporation pan waste water will overflow and spill onto the floor if the heater is not properly operating.

Remove accumulated debris from the evaporation pan. Wipe down heater coil with a cloth and warm water. Be sure to remove any dirt, debris or liquids from the heater coil.

Water introduced during cleaning will cause the evaporation pan to overflow.



PRECAUTION CLEANING PRECAUTIONS

When Cleaning:

- Do not use high pressure water hoses
- Do not introduce water faster than waste outlet can drain
- NEVER INTRODUCE WATER ON SELF CONTAINED UNIT WITH AN EVAPORATION PAN
- NEVER USE A CLEANING OR SANITIZING SOLUTION THAT HAS OIL BASE (these will dissolve the butyl sealants) or an AMMONIA BASE (this will corrode the copper components of the merchandiser)
- TO PRESERVE THE ATTRACTIVE FINISH:
 - Use a water and a mild detergent for the exterior only
 - Do NOT use a chlorinated cleaner on any surface
 - Do NOT use abrasives or steel wool scouring pads (these will mar the finish)

Self-Contained Refrigeration Equipment Maintenance Check List

***** Warranty does not cover issues caused by improper installation or lack of basic preventative maintenance. *****	
Record starting date	
Store Name and Number	
Store Address	
Unit Model Number	
Unit Serial Number	
Contractor/Technician	

	Technician		Q1	Q2	Q3	Q4	Q1	Q2	Q3	Q4
	Quarterly	Semi-Annually								
PM activity-For visual inspection items, denote "ok or complete" in the column to right when PM has been performed. For measured data requested, record data requested in the appropriate column to the right)										
Check in with store manager, record any complaints or issues they have with unit.	X									
Look unit over for any damage, vibrations or abnormal noise.	X									
Verify unit is level side to side and front to rear.	X									
Confirm refrigerant lines properly are secured and not touching or rubbing other lines, wires or frame work.	X									
Verify fan motors and motor mounts are tight.	X									
Confirm fan blade/s are tight and not rubbing or hitting.	X									
Make sure all electrical connections, factory and field, are tight.	X									
Verify electrical connections at lamps are they secure and dry.	X									
Check for and replace any frayed or chaffed wiring.	X									
Check all electrical wiring make sure it is secured and not on any sharp edges or hot lines.	X									
Check for air disturbances external to the unit. Heat and air registers, fans, and doors etc.	X									
Check for water leaks.	X									
Clean evaporator coil/s and fan blade/s. Do not use an acid base cleaner. Rinse off any cleaner residue.		X								
Clean discharge air honeycombs or grilles. Do not use an acid base cleaner. Rinse off any cleaner residue.		X								
Clean condenser coil/s and fan blade/s. Do not use an acid base Cleaner. Rinse off any cleaner residue.		X								
Clean condensate drain pan and drain line.		X								
Verify condensate drain lines are clear and functioning.		X								
Record voltage reading at unit with unit off?		X								
Verify condenser and evaporator fans are working.	X									
Record condenser air inlet temperature	X									
Record condenser air outlet temperature	X									
Is condenser air inlet or air exhaust restricted or recirculating?	X									
Verify there are no visual oil or refrigerant leaks.	X									
Record voltage reading with unit running.		X								
Record compressor amp draw.		X								
Record defrost heater voltage and amp draw.		X								
Record anti-sweat heater voltage and amp draw.		X								
Record case product temperature.	X									
Record unit discharge air temperature.	X									
Record unit return air temperature.	X									
Record ambient conditions around unit (wet Bulb temperature and dry bulb temperature).	X									
Check product loading, do not load beyond the units load limits.	X									
Verify clearances on sides/back of unit.	X									
Check unit controller for proper operation. See controller or 1/0 Manual for proper controller operation.		X								
Confirm door switches function.	X									
Verify unit doors and lids work and are sealed correctly.	X									
Verify that all the panels, shields and covers are in place.	X									

Technician Notes:

4-6 MAINTENANCE

NOTES:

SERVICE

REPLACING FAN MOTORS AND BLADES

Should it ever be necessary to service or replace the fan motors or blades be certain that the fan blades are reinstalled correctly. **THE BLADES MUST BE INSTALLED WITH RAISED EMBOSSED (PART NUMBER ON PLASTIC BLADES) POSITIONED AS INDICATED ON THE PARTS LIST.**

For access to these fans:

1. Remove product and place in a refrigerated area. Turn off power to the merchandiser.
2. Remove bottom display pans.
3. **Disconnect fan from wiring harness.**
4. Remove fan blade.
5. Lift fan plenum and remove screws holding bottom of motor to fan basket.
6. Replace fan motor and blade.
7. Lower fan plenum.
8. Reconnect fan to wiring harness.
9. Turn on power.
10. Verify that motor is working and blade is turning in the correct direction.



WARNING

Product will be degraded and may spoil if allowed to sit in a non-refrigerated area.



WARNING

— **LOCK OUT / TAG OUT** —

To avoid serious injury or death from electrical shock, always disconnect the electrical power at the main disconnect when servicing or replacing any electrical component. This includes, but is not limited to, such items as doors, lights, fans, heaters, and thermostats.

11. Close air gaps under fan plenum. Warmer air moving into refrigerated air reduces effective cooling. If the plenum does not rest against the case bottom without gaps, apply foam tape to the bottom of the fan plenum to reduce improper air movement. Use silicone sealant to close other gaps.
12. Reinstall display pans. Bring merchandiser to operating temperature before restocking.

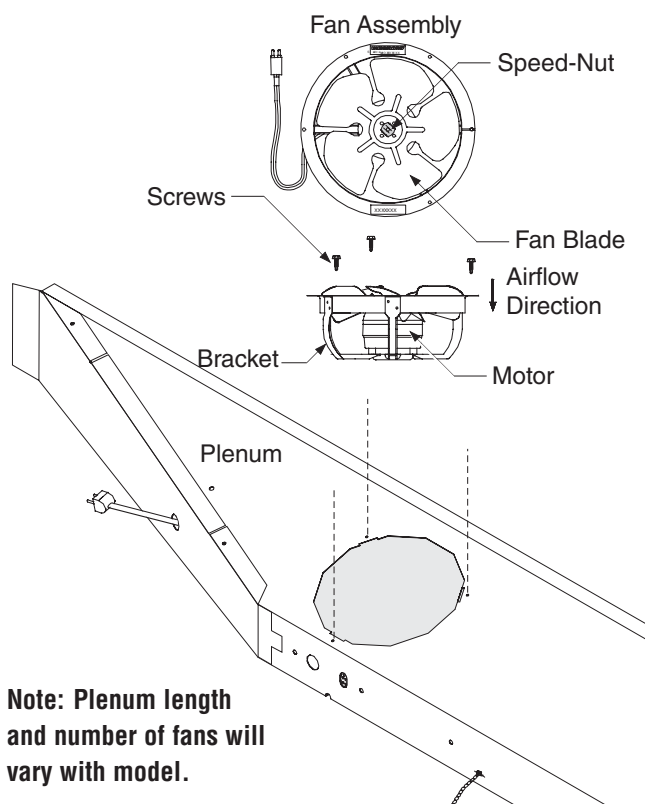

Replacing ISMGG / ISFGG Anti-Sweat Heaters

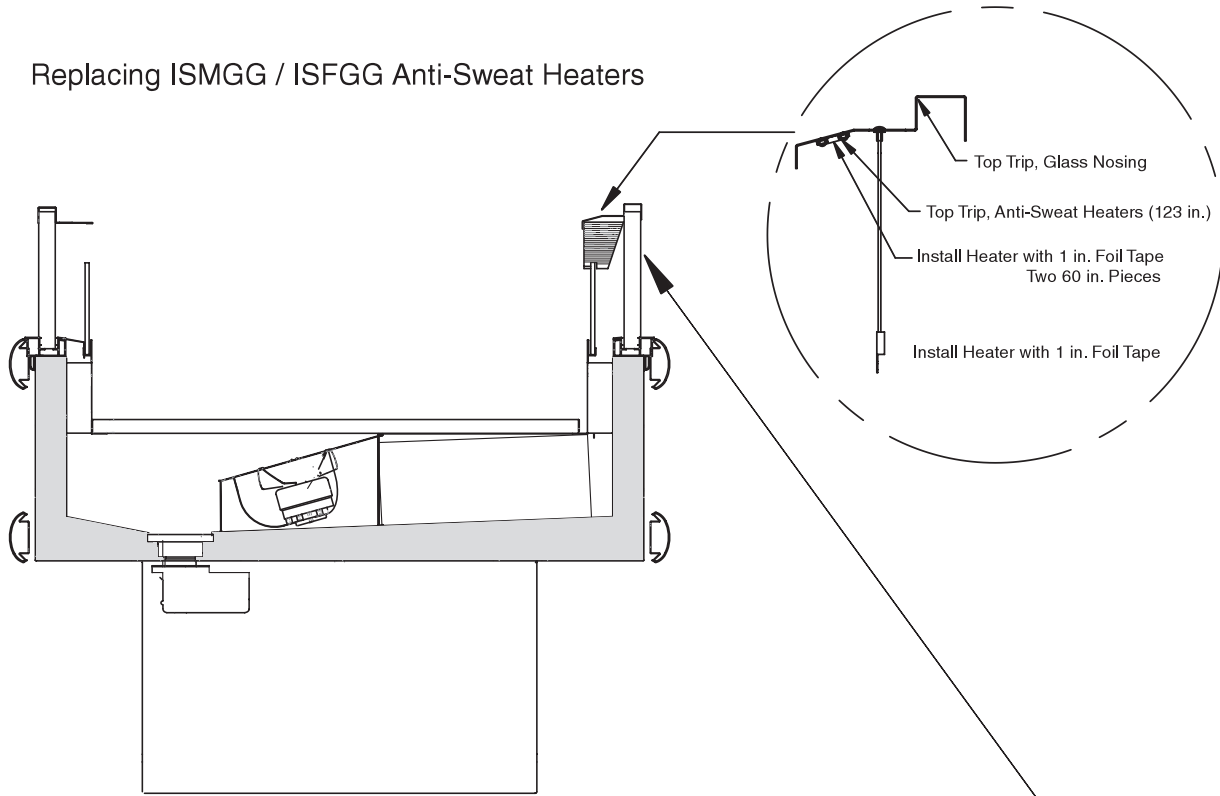

Assembly End Glass and Anti-Sweat Heater

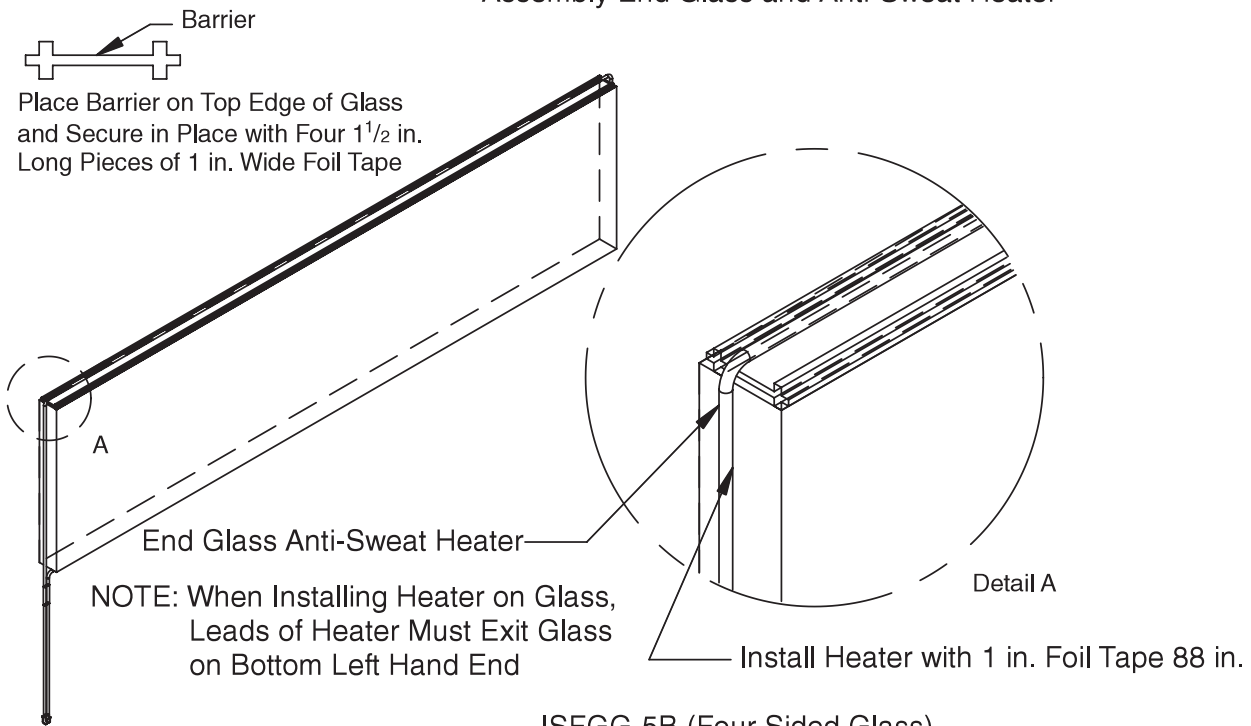

ISFGG-5B (Four Sided Glass)

NOTE: ISMGG-5B Glass Assembly has no Anti-Sweat Heaters on Glass

**REPLACING NOSING
ANTI-SWEAT HEATER
(Not All Models)**

To replace the heater:

1. Remove product and place in a refrigerated area. Turn off power to the merchandiser.
2. Remove the interior panels from under the nosing heater to be replaced by lifting them up and out.
3. Remove interior panel support bracket .
4. Remove existing screws from sheet metal nosing panel; remove panel.
5. Remove insulation.
6. Unplug and remove existing anti-sweat heater taped to sheet metal nosing panel. In most applications anti-sweat heater plug is routed on left-hand side from front of merchandiser.
7. Tape anti-sweat heater as shown in the illustrations. Route plug to jumper harness. If price tag molding is installed, allow clearance between screws and wiring. Make sure that the edge of foil tape is seated properly. Failure to do so will cause damage to the wiring and heater.
8. Reinstall insulation, sheet metal nosing panel screws, interior panel support bracket and interior panels.
9. Turn on power to merchandiser and check for proper operation.
10. Bring merchandiser to operating temperature before restocking. Refer to illustrations on the previous page.

5-4 **Service**

NOTES:

Replacement Parts list

Models

Standard Parts

Description

Part Number **ISFGG-5D/G** **ISFGG-10D/G** **ISMGG-5B** **ISMGG-10B**
 208/230V **208/230V** **115V** **115V**

Telescopic Wire Display Shelf (White or Black)	22S299	X	X	X	X
Power Switch	03S422	X	X		
Power Switch	03S286			X	X
Power Cord (230v/20A)	1804385	X	X		
Power Cord (120v/20Amp)	19S636			X	X
Drain Cover	0462289	X	X	X	X
Thermometer (solar)	05S521	X	X	X	X
Flue Glass (Interior)	29S861	X	X	X	X
Flue Glass Filler (used only if no Insulated partition ISF/M-10)	29S902		X		X
Glass End	29S860	X	X	X	X
Glass Front & Rear	29S859	X		X	
Glass Front & Rear	29S900		X		X
Trim Corner Post (Stainless Steel)	05S609	X	X	X	X
Trim -Top End Glass (Stainless Steel)	05S604	X	X	X	X
Trim-Top Glass Front (Stainless Steel) Return Air	14080	X		X	
Trim-Top Glass Front (Stainless Steel) Return Air (Special w/1" dial KO	140801002	X		X	
Trim-Top Glass Discharge Side (Stainless Steel)	14038	X		X	
Trim-Top Glass Front (Stainless Steel) Return Air	14206		X		X
Trim-Top Glass Front (Stainless Steel) Return Air (Special w/1" dial KO	14206-1		X		X
Trim-Top Glass Discharge Side (Stainless Steel)	14205		X		X
Plastic Discharge Louver	0472598	X	X	X	X

Models

Refrigeration

Description

Part Number **ISFGG-5D/G** **ISFGG-10D/G** **ISMGG-5B** **ISMGG-10B**
 208/230V **208/230V** **115V** **115V**

Compressor (Copeland KALB-010E-CAV-220)	02S445	X	X		
Assembly Condensing Unit (with suction line assembly)	0548950			X	X
Condensing Unit (M4FH005-CAA-212) Comp ASE32C3E-CAA	0514218			X	X
Condenser	25S114	X	X		
Condenser Fan Motor	21S071	X	X		
Condenser Fan Blade	21S140	X	X		
Condenser Fan Motor Mounting Bracket	0210135	X	X		
Receiver (Sporlan M30E-43)	17S568	X	X		
CPR (Sporlan CROT-6-0/60)	0514213	X	X	X	X
Suction line Assy	0514448	X	X		
Suction line Assy	0514797			X	X
Pressure Control Switch Assy	0514705	X	X	X	X
Pressure Control Switch	03S558	X	X	X	X
Evaporator Coil Assy (TEV, Distributor,Drier,Ht X'chr.)	0514452	X	X		
Evaporator Coil	0500343	X	X	X	X
Distributor	0468538	X	X	X	X
Drier (C-03E124)	0501739	X	X	X	X
TXV (Sporlan C-03E124)	0472727	X	X		
Evaporator Coil Assy (TEV, Distributor,Drier,Ht X'chr.)	0514787			X	X
TXV (Sporlan FBSE-1/4C)	0514214			X	X
Evaporator Fan Motor Assy (230V, 4W, 7" dia) Motor ,Blade & Basket	0478746	X	X		
Evaporator Fan Motor Assy (115V, 4W, 7" dia) Motor ,Blade & Basket	0477665			X	X
Evap Fan Motor	0477653			X	X
Evap Fan Blade (7" Dia.)	0464847	X	X	X	X
Evap Fan Motor	0477659	X	X		
Evap Fan Motor Bracket	0464849	X	X	X	X

Replacement Parts list CONTINUED

Models**Heaters & Harnesses**

Description	Part Number	ISFGG-5D/G	ISFGG-10D/G	ISMGG-5B	ISMGG-10B
		208/230V	208/230V	115V	115V
Defrost Heater 208/230V, 800W	0514239	X	X		
Condensate Pan Heater 208V, 500W (Not for USA / Canada)	19S766	X	X		
Condensate Pan Heater 120V, 570W (Not for USA / Canada)	19S757			X	X
Condensate Pan Assy w/Heater	141823	X	X		
Hi-Humidity Condensate Pan Kit (100W, 230V, 15A) Order only if replacing standard condensate pan	141826	X	X		
Hi-Humidity Condensate Pan (100W, 230V, 15A) Order only if replacing a Hi-humidity pan	0538245	X	X		
Hi-Humidity Condensate Pan Kit (100W, 120V, 15A) Order only if replacing standard condensate pan	QB84			X	X
Hi-Humidity Condensate Pan (100W, 120V, 15A) Order only if replacing a Hi-humidity pan	0538249			X	X
Condensate Pan Assy w/Heater	141821			X	X
Anti-Sweat Heater- End Glass 230V, 5.7W, 96"	0514215	X	X		
Anti-Sweat Heater Front and Rear Glass 230V, 5.7W, 140"	0514217	X			
Anti-Sweat Heater Front and Rear Glass 230V, 5.7W, 270"	0514957		X		
Anti-Sweat Heater Discharge Air 230V, 2.8w, 123" (2 on ISFGG10)	0514216	X	X		
Anti-Sweat Heater Discharge Air 120V, 2.8w/ft., 123" (2 on ISFMG10)	19S758			X	X
Wire Harness AS Heaters	19S787	X	X		
Nose Heater Wire Harness	19S753			X	X
Fan Harness	19S750	X	X	X	X

Models**Sheet Metal Replacement Parts Painted**

Description	Part Number	ISFGG-5D/G	ISFGG-10D/G	ISMGG-5B	ISMGG-10B
		208/230V	208/230V	115V	115V
Front & Rear Access Panel	144101	X	X	X	X
Decorative Panel (between bumper)	14254	X		X	
Decorative Panel Front & Rear (between bumper)	14277		X		X
Decorative Panel Ends (between bumper)	14275		X		X
Access Panel Spacer	14284		X		X
Cover- Base ends	14016	X	X	X	X
Display Pan Assy (White Std, Black Option)	14042	X	X	X	X
Corner Bumper 90°-Metal (Matches bumper color/Specify bumper color)	05S604	X	X	X	X
Cap Interior Center (ISF/M-10 only) Used if no Insulated Partition	14204		X		X
Center Insulated Partition Assy (Used on ISFGG10 Only w/ Dual Temp Kit MV20)	141752		X		
Thermometer Mounting Bracket (For Solar Thermometer)	0531902	X	X	X	X

*All these part numbers below are painted assemblies (standard color is White)

Controller Parts

Description	Part Number	ISFGG-5D/G 208/230V	ISFGG-10D/G 208/230V	ISMGG-5B 115V	ISMGG-10B 115V
Sensor NTC 4 mts Green	3023554	X	X	X	X
Sensor NTC 4 mts Orange	3031571	X	X	X	X
Control Eliwell RTN400	3023537	X	X	X	X
Control Display KDE	3023552	X	X	X	X
Display cable 5 meter	3023553	X	X	X	X
Compressor & Defrost Relay (120V)	0459304			X	X
Compressor/Defrost Relay/AS (220V)	1804241	X	X		

ISF - ISM

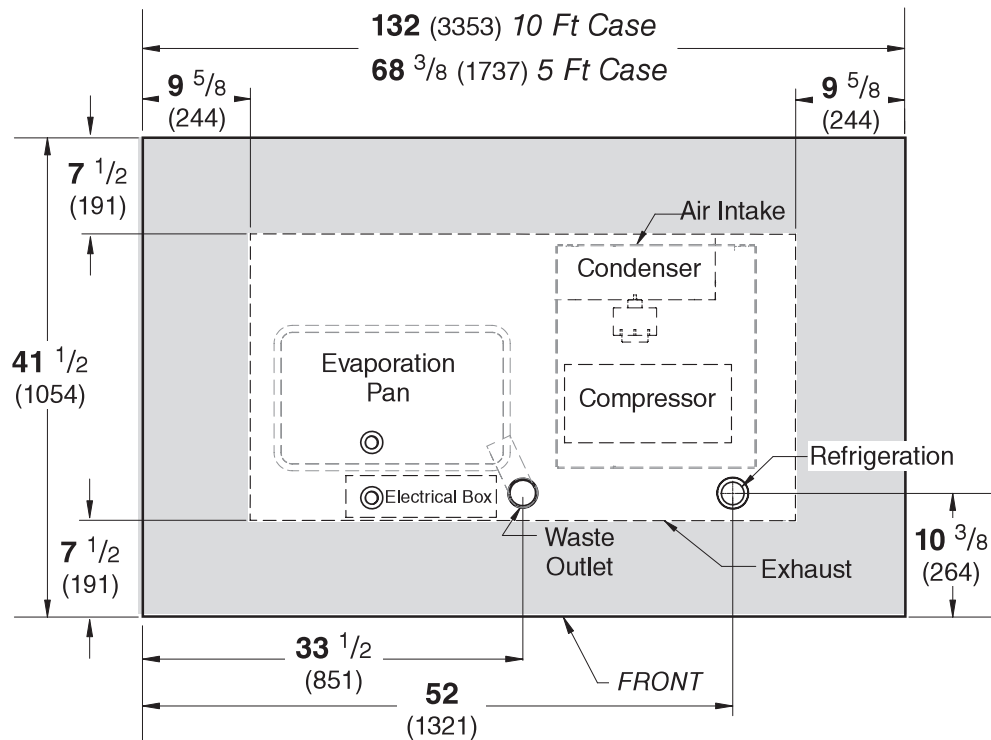

General

Case Length (<i>Note: Includes One Pair Ends</i>)	5ft (68 3/8) (1737)	10ft (3353)
Optional End Bumpers (<i>One Pair</i>)	2 (51)	2 (51)
Maximum O/S dimension of case back to front (<i>Note: Includes bumper</i>)	43 1/2 (1105)	87 (2210)
Width of skid rail	9 5/8 (244)	19 1/4 (488)

Waste Outlet

LH end of case (<i>from outside of End Assembly</i>) to center of waste outlet	33 1/2 (851)	67 (1702)
---	--------------	-----------

A-4 APPENDIX A — TECHNICAL DATA

Dimensions shown as inches and (mm).

ISF - ISM

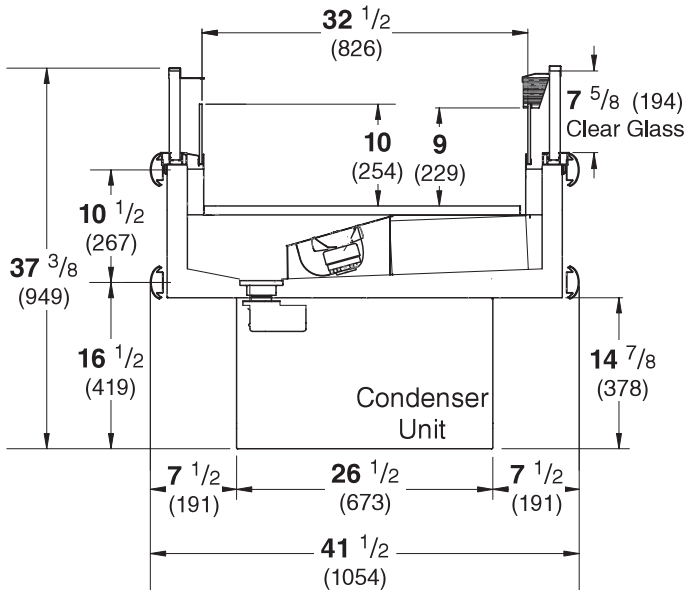

REFRIGERATION DATA

ISF5GG & ISM5GG

	ISF	ISM
Condensing Unit (hp)	1	0.5
Condensing Unit Capacity (Btu/hr at std. rating conditions)	4280	2660

DEFROST DATA

	ISF	ISM
Frequency (hr)	6	12
OFFTIME		
Failsafe (minutes)	50	50
Defrost Termination Temperature °F	48	48

PHYSICAL DATA

Refrigerant Charge		
ISF	48 oz	1.36 kg
ISM	30 oz	.85 kg

Note: This data is based on store temperature and humidity that does not exceed 80°F and 55% R.H. unless otherwise stated. Schedule defrost at night while lights are off.

Electrical Data

Note: These are rated values for individual components and should not be added together to determine total merchandiser electrical load.

	ISF-5	ISM-5		
Number of Fans – 4W	1	1		
	Amperes		Watts	
	ISF-5	ISM-5	ISF-5	ISM-5
Evaporator Fans				
230V 60Hz Standard	0.06		8	
115V 60Hz Standard		0.12		8
Condensate Pan Heaters (208V)	4.2		1000	
Condensate Pan Heaters (120V)		8.3		1000

ISF-5 / ISF-10

Condensing Unit (208/230V, 1Ph, 60Hz) Standard

Minimum Circuit Ampacity	9.7
Compressor LRA	40.0
Compressor RLA	6.9

ISM-5 / ISM-10

Condensing Unit (115V, 1Ph, 60Hz) Standard

Minimum Circuit Ampacity	12.3
Compressor LRA	33.6
Compressor RLA	9.2

Product Data

ISF/ISM-5GG

*AHRI Total Display Area*¹ (Sq Ft/Case) 21.3 ft² /case (1.98 m² /case)

Computed using AHRI 1200 standard methodology:
 Total Display Area, ft² [m²] / Unit of Length, ft [m]

	Nominal HP	Refrigerant Type	Volts	Run Amps	Nema Plugs	Fuse Amps	Hz/Ph
ISFGG-5D/G	1	R404a	208/230	15.7	6-20P	20	60/1
ISFGG-10 D/G*	1HP x 2	R404a	208/230	15.7 x 2	6-20P 20 x 2	20 x 2	60/1
ISMGG-5B	1/2	R404a	115	15.9	5-20P	20	60/1
ISMGG-10B*	1/2 HP x 2	R404a	115	15.9 x 2	5-20P x 2	20 x 2	60/1

* All 10 ft. models have two separate condensing units, electrical boxes and power cords

ESTIMATED SHIPPING WEIGHT ²

Case

<i>ISF-5</i> <i>(Self Contained)</i>	<i>ISM-5</i> <i>(Self Contained)</i>	<i>End</i>
670 lb (304 kg)	725 lb (329 kg)	Included

<i>ISF-10</i> <i>(Self Contained)</i>	<i>ISM-10</i> <i>(Self Contained)</i>	<i>End</i>
1340 lb (609 kg)	1450 lb (658 kg)	Included

² Actual weights will vary according to optional kits included.

ISFGG-5DG — Self Contained

WARNING
UNPLUG THE EQUIPMENT BEFORE TO MAKE ANY REPARATION TO AVOID ANY DAMAGE

ADVERTENCIA:
DESCONECTAR EL EQUIPO ANTES DE HACER CUALQUIER REPARACION, PARA EVITAR ALGUN DAÑO.

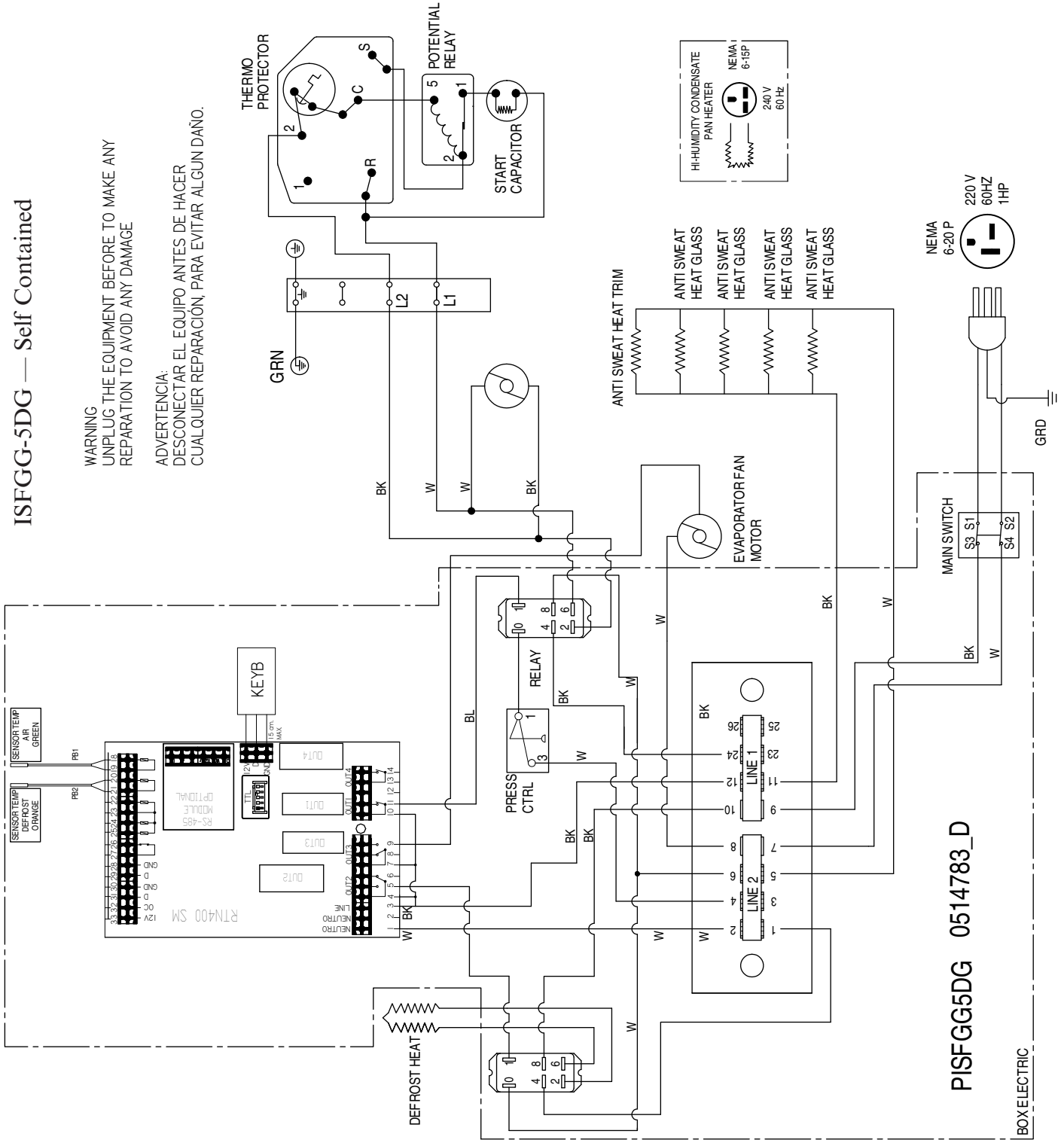

WARNING

All components must have mechanical ground, and the merchandiser must be grounded.

R = Red Y = Yellow G = Green BL = Blue BK = Black W = White

ISMGG-5B — Self Contained

WARNING
UNPLUG THE EQUIPMENT BEFORE TO MAKE ANY REPAIRATION TO AVOID ANY DAMAGE

ADVERTENCIA:
DESCONECTAR EL EQUIPO ANTES DE HACER CUALQUIER REPARACION, PARA EVITAR ALGUN DAÑO.

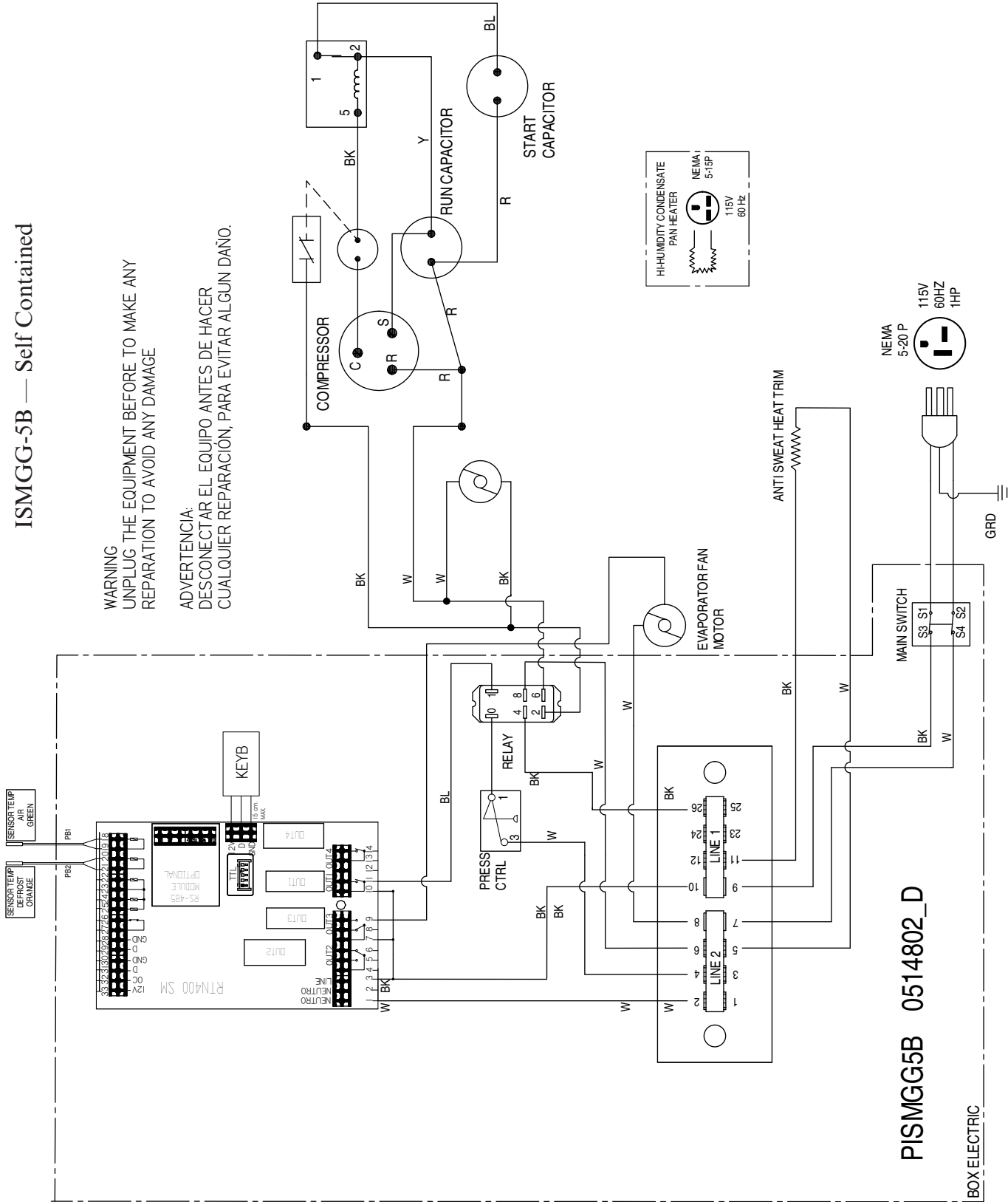

PISMGG5B 0514802_D

BOX ELECTRIC

WARNING

All components must have mechanical ground, and the merchandiser must be grounded.

R = Red Y = Yellow G = Green BL = Blue BK = Black W = White

ISF-GG10DG — Self Contained
(two condensing units, the other
similar)

0548783_D

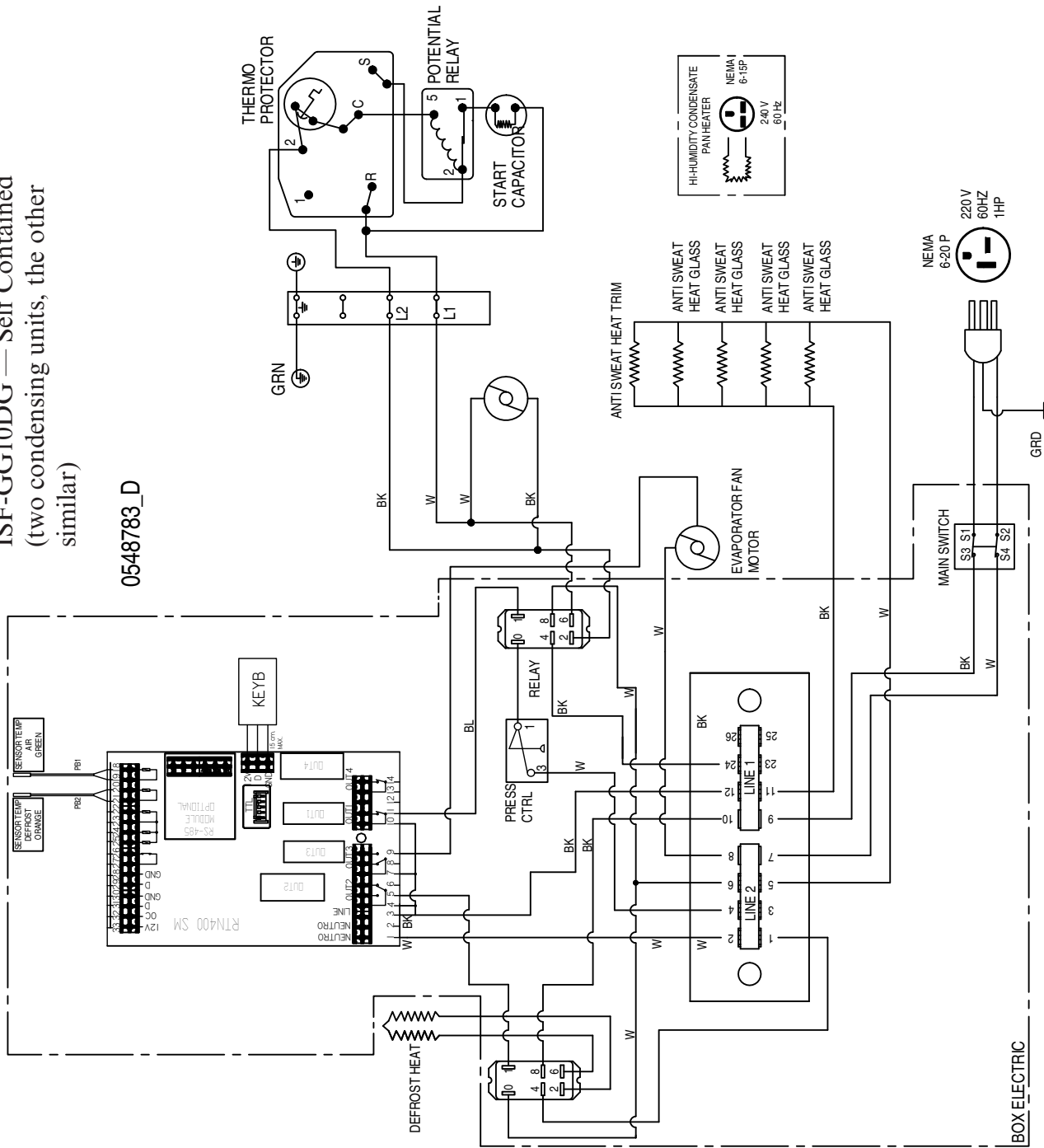

WARNING

All components must have mechanical ground, and the merchandiser must be grounded.

R = Red Y = Yellow G = Green BL = Blue BK = Black W = White

ISMGG-10B — Self Contained
(two condensing units, the other similar)

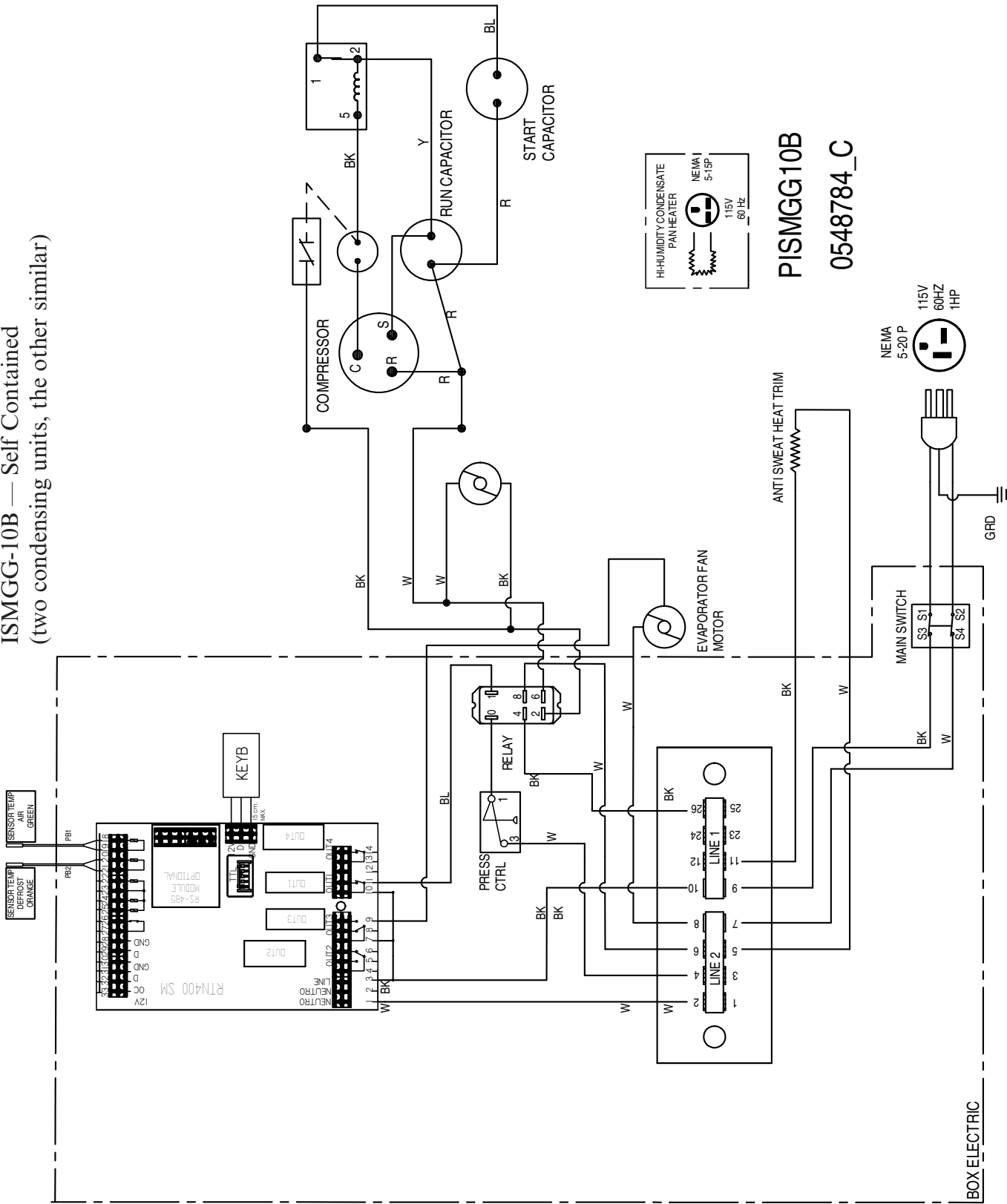

PISMGG10B
0548784_C

WARNING

All components must have mechanical ground, and the merchandiser must be grounded.

R = Red Y = Yellow G = Green BL = Blue BK = Black W = White



HUSSMANN[®]

**To obtain warranty information
or other support, contact your
Hussmann representative.
Please include the model and
serial number of the product.**

Hussmann Corporation, Corporate Headquarters: Bridgeton, Missouri, U.S.A. 63044-2483 01 October 2012

Husmann Corporation

12999 St. Charles Rock Road
Bridgeton, MO 63044-2483
www.husmann.com