

HUSSMANN®



DOE 2017
Energy Efficiency
Compliant

SHM

Medium Temperature Self Contained Specialty Horizontal Merchandiser



Shown with 3-sided Bumper

Installation & Operation Manual

IMPORTANT
Keep in store
for future reference!

MANUAL- I/O SELF-CONTAINED SHM

P/N 0515258_M
September 2017

Spanish 0531303
French 0531304

ATTENTION

Merchandiser must operate for 24 hours
before loading product!

Regularly check merchandiser temperatures.

Do not break the cold chain. Keep products
in cooler before loading into merchandiser.

These merchandisers are designed
for pre-chilled products only.



IMPORTANT
KEEP IN STORE FOR FUTURE REFERENCE
Quality that sets industry standards!

12999 St. Charles Rock Road • Bridgeton, MO 63044-2483

U.S. & Canada 1-800-922-1919 • Mexico 01 800-890-2900

www.hussmann.com

© 2017 Hussmann Corporation

TABLE OF CONTENTS

ANSI Z535.5 DEFINITIONS vi

INSTALLATION

UL Listing 1-1
Federal / State Regulation 1-1
Husmann Product Control 1-1
Shipping Damage 1-1
Location 1-1
Self Contained Location 1-2
Model Description 1-3
Unloading 1-3
Exterior Loading 1-3
Shipping Skid 1-3
Merchandiser Leveling 1-4
Optional Legs 1-4
Serial Plate Location 1-4
Refrigeration Unit Access 1-4
Sealing Merchandiser to Floor 1-4
Optional Night Curtain 1-5
Self-Contained Refrigeration Equipment
Start Up Check List 1-7

Controls Adjustments 3-9
Start Up 3-10
Load Limits 3-10
Stocking 3-10
Thermometer 3-10

MAINTENANCE

Care and Cleaning 4-1
Cleaning Discharge Honeycomb 4-2
Cleaning Stainless Steel Surfaces 4-2
Cleaning Under Step Pan 4-2
Cleaning Thermometer 4-3
Cleaning Coils 4-3
Cleaning Evaporation Pan 4-4
Removing Scratches from Bumper 4-4
Maintaining Fluorescent Lamps 4-4

ELECTRICAL / REFRIGERATION

Merchandiser Electrical Data 2-1
Field Wiring 2-1
Electrical Connections 2-1
Electrical Outlet 2-1
Refrigeration (Self Contained) 2-1
Waste Outlet and Water Seal 2-2

SERVICE

Replacing Fan Motors and Blades 5-1
Replacing Lights 5-2
Replacing Ballast / Power Supply 5-2

START UP / OPERATION

Controller Operation 3-1
Key Function 3-2
Further Information 3-3
Connections 3-4
LED 3-5
KDE PLUS Buttons 3-6
Setpoint 3-7
Sensor to Control Configuration 3-8

APPENDIX

Part Numbers A-1
Plan View & Dimensions A-4
Cross Section View & Data A-5
Electrical Data & Product Data A-6
Electrical Cont. & Shipping Weight A-7
SHM Self Contained Case Wiring A-8

WARRANTY

REVISION HISTORY

REVISION M

1. Page 1-4 - Replaced image of the display & cable
-Replaced display picture
2. Page 3-1 to 3-5-Remove Safe-NET Controller Information
3. Page 3-6 -Replaced pictures with coil to ctrl
4. Page 3-7-Change Defrost Frequency from 2 to 3
-Change Temp Termination from 52 to 48
-Change Controller info on first paragraph to controller
-Remove word knob
5. Page 3-8 -Changed controller information
6. Page A-1-Removed selected components -Add Controller parts
7. Page A-3 -Replaced SNIII with “Ctrl Display” on 291431 & 291432 descriptions
8. Page A-5 -Remove selected information; On Defrost Data Change Frequency from 12 to 8 and Defrost Termination from 52 to 48
9. Page A-8/A-9-Replaced diagrams with new revisions

REVISION L

Removed; For USA/CANADA, a Hi-Humidity Condensate Pan Kit is provided with SHM-3; Revised Part Numbers, Page A-1 and Condensate Pan numbers on, Page A-2. Change fuse Amps 30 15, Page A-7; new wiring diagram, Page A-8

REVISION K

NEMA Plug, 2-1; Condensate Pan Note, 2-2; New Part, A-2; Updated tables, A-5; Updated tables, A-6; Updated table A-7; Updated Wiring Diagrams, A-8

REVISION J

Revised Parts List, A-2; Revised Wiring Diagram, A-8 A-9; Shipping Weight, Page A-7

REVISION H

Revised Refrigeration Charge, A-5

REVISION G — Note on cover page. Removed model SHM-4BW, Page 1-2, Added California Prop 65 Warning, Page 1-2 Updated Night Curtain Instructions, Page 1-5 Added New Parts List, Page A-1

REVISION F — Added Checklists Page 1-7; Added Warning Page 1-3; Cleaning Coils 4-3; Maintaining Fluorescent Lights 4-4. Checklist Page 4-5

REVISION E — JULY 2013

1. Included Night Curtain Installation Instructions Page 1-5 and 1-6

REVISION D — FEBRUARY 2012

1. Changed NEMA plug
2. Removed Remote Case setup instructions

REVISION C — JANUARY 2012

1. Added LED Light Bars
2. Removed Remote Models
3. New Wiring Diagram SHM-3, SHM-4

REVISION B — DECEMBER 2010

1. Revised defrost settings, Page 3-3
2. Changed Defrost Frequency (2); Page 3-7
3. Revised defrost settings; Page A-3

ORIGINAL ISSUE — NOVEMBER 2010

ANSI Z535.5 DEFINITIONS



• **DANGER** – Indicate[s] a hazardous situation which, if not avoided, will result in death or serious injury.



• **WARNING** – Indicate[s] a hazardous situation which, if not avoided, could result in death or serious injury.



• **CAUTION** – Indicate[s] a hazardous situation which, if not avoided, could result in minor or moderate injury.

• **NOTICE** – *Not related to personal injury* – Indicates[s] situations, which if not avoided, could result in damage to equipment.

INSTALLATION

CERTIFICATION

These merchandisers are manufactured to meet ANSI / National Sanitation Foundation (NSF®) Standard #7 requirements. Proper installation is required to maintain certification. Near the serial plate, each case carries a label identifying the type of application for which the case was certified.

ANSI/NSF-7 Type I - Display Refrigerator / Freezer

Intended for 75°F / 55% RH Ambient Application

ANSI/NSF-7 Type II - Display Refrigerator / Freezer

Intended for 80°F / 55% RH Ambient Application

ANSI/NSF-7 - Display Refrigerator

Intended for Bulk Produce

HUSSMANN PRODUCT CONTROL

The serial number and shipping date of all equipment is recorded in Hussmann's files for warranty and replacement part purposes. All correspondence pertaining to warranty or parts ordering must include the serial number of each piece of equipment involved. This is to ensure the customer is provided with the correct parts.

SHIPPING DAMAGE

All equipment should be thoroughly examined for shipping damage before and during unloading. This equipment has been carefully inspected at our factory. Any claim for loss or damage must be made to the carrier. The carrier will provide any necessary inspection reports and/or claim forms.

Apparent Loss or Damage

If there is an obvious loss or damage, it must be noted on the freight bill or express receipt and signed by the carrier's agent; otherwise, carrier may refuse claim.

Concealed Loss or Damage

When loss or damage is not apparent until after equipment is uncrated, retain all packing materials and submit a written response to the carrier for inspection within 15 days.

LOCATION

These merchandisers are designed for displaying products in air conditioned stores where temperature is maintained at or below the ANSI / NSF-7 specified level and relative humidity is maintained at or below 55%.

<p>Recommended operating ambient temperature is between 65°F (18°C) to 75°F (23.9°C). Maximum relative humidity is 55%.</p>
--

Placing refrigerated merchandisers in direct sunlight, near hot tables or near other heat sources could impair their efficiency. Like other merchandisers, these merchandisers are sensitive to air disturbances. Air currents passing around merchandisers will seriously impair their operation. Do NOT allow air conditioning, electric fans, open doors or windows, etc. to create air currents around the merchandiser.

SELF CONTAINED LOCATION

Product should always be maintained at proper temperature. This means that from the time the product is received, through storage, preparation and display, the temperature of the product must be controlled to maximize the life of the product.

BE SURE TO POSITION SELF CONTAINED MERCHANDISERS PROPERLY.

SELF CONTAINED models have vented base panels to allow air circulation through the condensing unit.

See illustrations for clearances distances from walls, merchandisers, and any other large objects near the merchandiser’s vented base panels. Blocking or restricting air flow will adversely affect performance and may damage the refrigeration system.

For California Businesses:

! WARNING

This product may contain chemicals known to the State of California to cause cancer, birth defects, or other reproductive harm.

This warning is the result of the California State law known as the California Safe Drinking Water and Toxic Enforcement Act of 1986, which is commonly referred to as “Proposition 65.”

This warning does not mean that Hussmann products will cause cancer or reproductive harm, or is in violation of any product-safety standards or requirements. As clarified by the California State government, Proposition 65 can be considered more of a ‘right to know’ law than a pure product safety law. When used as designed, Hussmann believes that our products are not harmful. We provide the Proposition 65 warning to stay in compliance with California State law. It is your responsibility to provide accurate Proposition 65 warning labels to your customers when necessary. For more information on Proposition 65, please visit the California State government website.

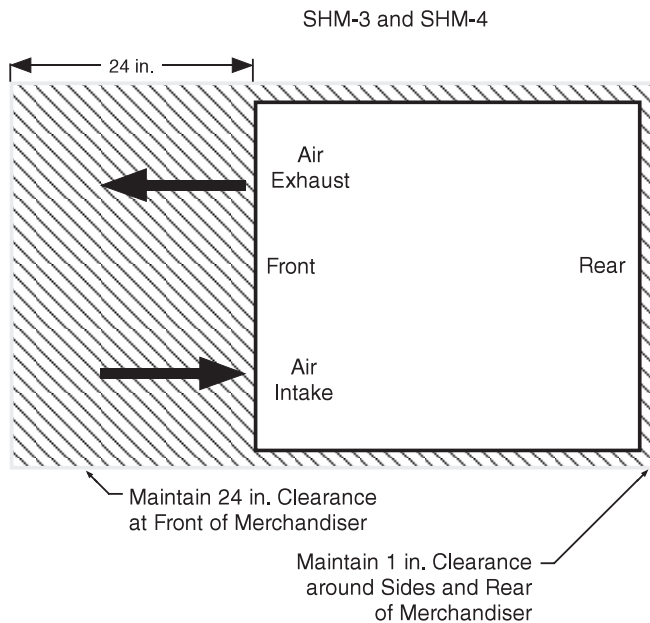

MODEL DESCRIPTION

SHM merchandisers offer versatility for the display of food items such as: fresh fruit, vegetables, cheeses and other delicatessen items. Carefully read and follow the instructions prior to operating the merchandiser.

UNLOADING

Unloading from Trailer:

Lever Bar (also known as a Mule, Johnson Bar, J-bar, Lever Dolly, or Pry Lever)

Move the merchandiser as close as possible to its permanent location and remove all packaging. Check for damage before discarding packaging. Remove all separately packed accessories such as kits and shelves.

Improper handling may cause damage to the merchandiser when unloading. To avoid damage:

1. Do not drag the merchandiser out of the trailer. Use a Johnson bar (mule).
2. Use a forklift or dolly to remove the merchandiser from the trailer.

EXTERIOR LOADING

Do NOT walk on top of merchandisers or damage to the merchandisers and serious personal injury could occur.

MERCHANDISERS ARE NOT STRUCTURALLY DESIGNED TO SUPPORT EXCESSIVE EXTERNAL LOADING such as the weight of a person. Do not place heavy objects on the merchandiser.

SHIPPING SKID

Each merchandiser is shipped on a skid to protect the merchandiser's base, and to make positioning the case easier.

Do not remove the shipping skid until the merchandiser is near its final location. The skid provides protection for both the merchandiser and the floor.

Remove the skid by raising one end of the merchandiser approximately 6 inches. Block the merchandiser securely, and remove the two skid bolts from the raised end. Replace the bolts with (provided) leg levelers. Repeat this procedure at opposing end. Once the leg levelers are secured in place, the merchandiser may be slid off the skid and placed in its final location.

DO NOT TILT MERCHANDISER ON ITS SIDE OR END WHEN REMOVING SKID.

Once the skid is removed, the merchandiser must be lifted —NOT PUSHED— to reposition.

Check floor where merchandisers are to be set to see if it is a level area. Determine the highest part of the floor.

WARNING

Do NOT remove shipping crate until the merchandiser is positioned for installation.

WARNING

Do NOT stand or walk on top of merchandiser. Do not store items or flammable materials atop the unit.

MERCHANDISER LEVELING

BE SURE TO POSITION MERCHANDISERS PROPERLY. Level the merchandiser by all four corners. Merchandiser(s) must be installed level to ensure proper operation of the refrigeration system, and to ensure proper drainage of defrost water. Optional leg levelers can be provided for this purpose.

OPTIONAL LEGS

NSF® approved legs replace the leg levelers if required by local health codes. The legs raise the case 6 inches for cleaning purposes. An optional skirt kit can be provided to snap on the legs.

SERIAL PLATE LOCATION

The serial plate is located on the interior left wall of the merchandiser. It contains all pertinent information such as model, serial number, amperage rating, refrigerant type and charge. This information will be needed to install, service or order parts for the merchandiser.



REFRIGERATION UNIT ACCESS

The lower access panel may be removed by lifting the panel straight upward and over the screws on which it is hanging. The panel is installed by reversing the above procedure.

Ensure lower access panel is flat against the floor when installed to prevent air circulation problems on self contained merchandisers.



Lift up and out to remove access panel



Display is mounted on left side of access panel. Be careful not to detach cable from display when removing access panel.



SEALING MERCHANDISER TO FLOOR

If required by local sanitary codes, or if the customer desires, merchandisers may be sealed to the floor using a vinyl cove base trim. The size needed will depend on how much variation there is in the floor, from one end of the merchandiser to the other. Sealing of the lower front and rear panels on self contained models may hamper their removal for servicing or maintenance of the condensing unit.

NOTE: Do not allow trim to cover any intake or discharge grilles located in the lower front panel.

(OPTIONAL) NIGHT CURTAIN

Night curtains are used to cover the case opening after normal business hours. The curtains improve energy consumption, allowing the refrigeration system to work less. Night curtains ordered with the case are factory installed.

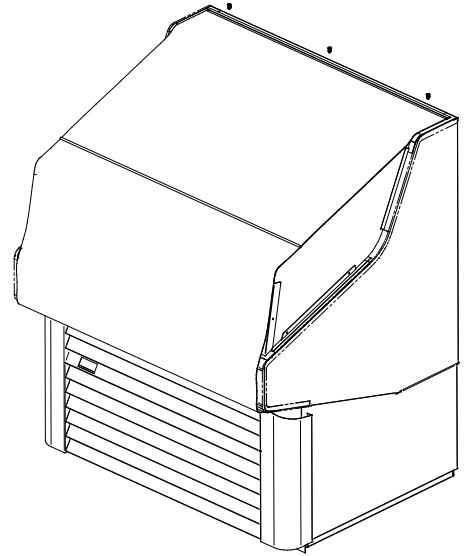

PARTS LIST (per curtain)

Item	Quantity	Description
------	----------	-------------

1.	1	Night Curtain
----	---	---------------

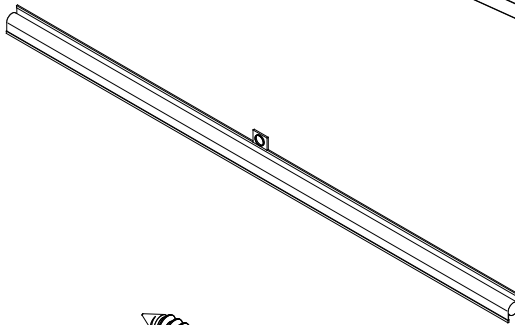

2.	3	Screw Phil Pan (#8)
----	---	---------------------



3.	1	Clip bottom
----	---	-------------

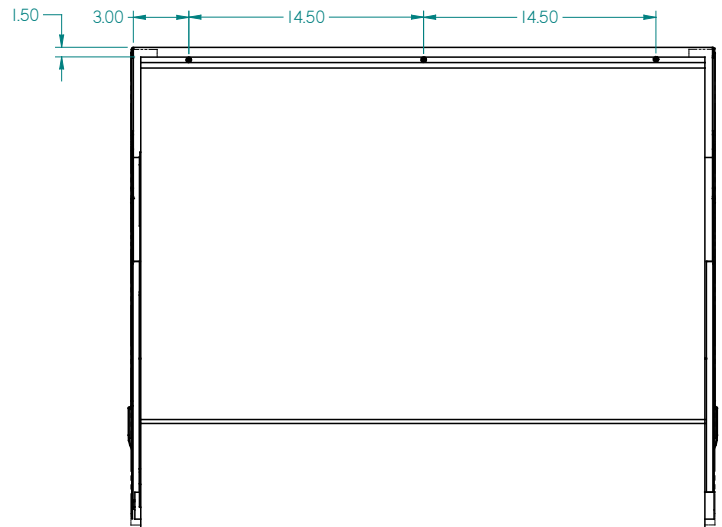
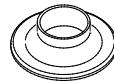

1. Put night curtain on top panel, one end of the will use to curtain to fasten screw. Take a distance 1.50 inches to edge part end night curtain. And center night curtain to length case.

2. Use 3 Screw, Phil Pan, #8 X 1/2"



- 3. Put clip in bottom, take to reference access panel 2.00 inches

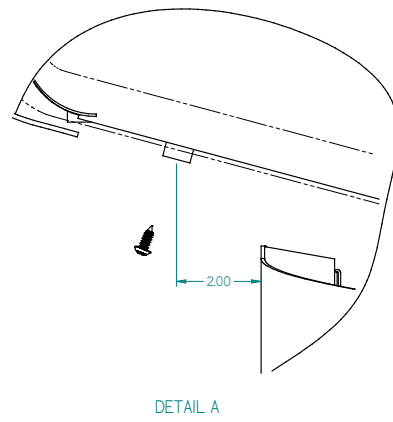
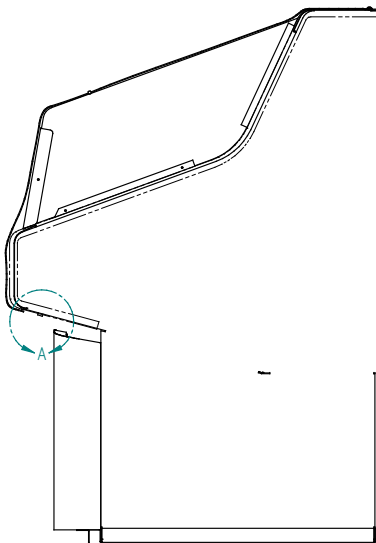
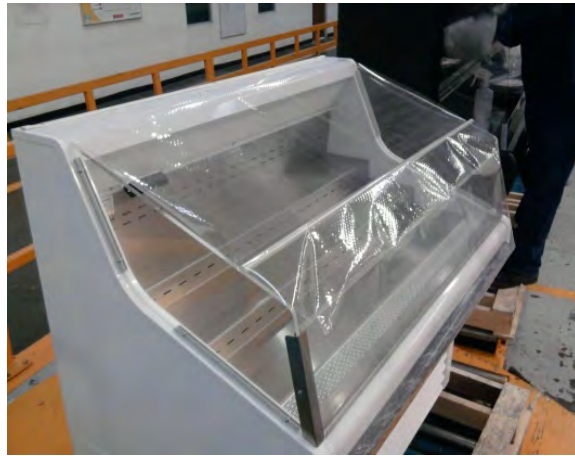

Hussmann Self-Contained Refrigeration Equipment Start Up Check List

Please note that failure to follow this start-up document may void your factory warranty

Step	Startup Activity	Check
1	Locate, read and maintain install/operation manual in a safe place for future reference.	<input type="checkbox"/>
2	Examine unit. Confirm there is NO damage or concealed damage.	<input type="checkbox"/>
3	Level the unit, side to side and front to rear.	<input type="checkbox"/>
4	Remove all shipping brackets/compressor straps/bolts etc.	<input type="checkbox"/>
5	Unit must be run on a dedicated electrical circuit without the use of an extension cord.	<input type="checkbox"/>
6	Ensure that the proper electrical requirements for the equipment are supplied.	<input type="checkbox"/>
7	Verify field electrical connections are tight.	<input type="checkbox"/>
8	Verify all electrical wiring is secured and clear of any sharp edges or hot lines.	<input type="checkbox"/>
9	Verify the condensate drain line is properly trapped and pitched.	<input type="checkbox"/>
10	Verify all required clearances on the sides and back of unit.	<input type="checkbox"/>
11	Verify there are no air disturbances external to the unit. Heat and air registers, fans, and doors etc.	<input type="checkbox"/>
Advise owner/operator that merchandiser must operate at temperature for 24 hrs prior to loading with product.		

Form HSCW01 Rev. 30MAY12 P/N 0525209_B

LEGAL DISCLAIMER:

Hussmann shall not be liable for any repair or replacements made without the written consent of Hussmann, or when the product is installed or operated in a manner contrary to the printed instructions covering installation and service which accompanied such product.

1-8 INSTALLATION

NOTES:

ELECTRICAL / REFRIGERATION

MERCHANDISER ELECTRICAL DATA

Refer to Appendix A of this manual or the merchandiser's serial plate for electrical information.

FIELD WIRING

Field wiring must be sized for component amperes stamped on the serial plate. Actual ampere draw may be less than specified.

ALWAYS CHECK THE SERIAL PLATE FOR COMPONENT AMPERES

ELECTRICAL CONNECTIONS

All wiring must be in compliance with NEC and local codes. All electrical connections (*for remote models*) are to be made in the electrical *Handy Box* located behind the removable base panel at the left end of the merchandiser when facing the discharge air louver.

ELECTRICAL OUTLET

Before the merchandiser is connected to any wall circuit, use a voltmeter to check that the outlet is at 100% of the rated voltage. The wall circuit must be dedicated for the merchandiser. Failure to do so voids the warranty. Do not use an extension cord. Never plug in more than one merchandiser per electrical circuit.

- Always use a dedicated circuit with the amperage stated on the unit.
- Plug into an outlet designed for the plug.
- Do not overload the circuit
- Do not use long or thin extension cords. Never use adapters.
- If in doubt, call an electrician.

Self-contained models have factory-installed power cords attached at the electrical box.

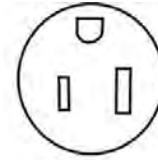

NEMA 5-15R Receptacle

WARNING

**Merchandiser must be grounded.
Do not remove the power supply cord ground.**

REFRIGERATION

(Self Contained Models)

Each self contained model is equipped with its own condensing unit and control panel located beneath the display area. The merchandiser refrigeration piping is leak tested. The unit is charged with refrigerant and shipped from the factory with all service valves open.

WARNING

— **LOCK OUT / TAG OUT** —

To avoid serious injury or death from electrical shock, always disconnect the electrical power at the main disconnect when servicing or replacing any electrical component. This includes, but is not limited to, such items as doors, lights, fans, heaters, and thermostats.

WARNING

Risk of Electric Shock. If cord or plug becomes damaged, replace only with a cord and plug of the same type.

REFRIGERATION**(Self Contained Models Continued)**

SHM-3 self contained merchandisers use R-404a refrigerant. SHM-4 self contained merchandisers use R-134a refrigerant. All models have a hermetic compressor. The systems employ capillary tubes for refrigerant flow control. The capillary tube is soldered to the suction line pull-out coil for proper heat exchange. **If the capillary should become plugged or damaged, it is best to replace the heat exchanger.**

**WARNING**

Refrigeration lines are under pressure. Refrigerant must be recovered before attempting any connection or repair.

WATER OUTLET AND WATER SEAL

The condensate water outlet is located in the center of the merchandiser. The outlet has a factory installed, external water seal.

For self contained models, this water seal drains into the condensate evaporator pan located beneath the merchandiser. The pan uses a thermistor that senses water in the pan and adjusts the amount of heat required to evaporate the water. **Ensure the drain hose is properly trapped, and the drain area is not clogged.**

NOTE: All lower base panels must be in place when the refrigerator is operating. If not, air-flow from the condenser will be directed over the evaporator pan and defrost water in the pan may overflow.

**CAUTION**

When brazing pipes, be sure to use the insulation blanket shipped with the merchandiser to prevent damage to the metal merchandiser bottom.

START UP / OPERATION

CONTROLLER OPERATION

The electronic controller is located in the cassette compartment. The controller comes factory set, and is ready for use. The front grille must be removed in order to access this control. When removing the grille for this operation or for condenser cleaning, care must be taken not to damage the display interface cable. It may be unplugged during this task.

1. Plug the merchandiser plug into its receptacle.
 - a. The controller display will illuminate.
 - b. The interior light will illuminate.
2. After the control preprogrammed time delay of up to 6 minutes, the compressor and evaporator fan(s) will start if the control is calling for cooling.
3. The control will cycle the compressor but may also cycle evaporator fan(s) on and off determined by the Set-Point and Differential temperatures.
 - a. The Set-Point is the adjustable preprogrammed temperature.
 - b. The Differential is the non-adjustable preprogrammed temperature.
 - c. The Control is designed to read and display a cabinet temperature not a product temperature.

This cabinet temperature may reflect the refrigeration cycle of the Set-Point and it's Differential. The most accurate temperature on a cabinets operation is to verify the product temperature.

Taking as an example a VRL case, freezer, If the Set-Point is -12°F and the Differential is 9°F. (Set-Point) -12°F + 9 (Differential) = -3°F. The compressor and evaporator fan(s) will cycle off -12°F and back on at -3°F.

Main Features:

- Panel-mounted
- Energy saving algorithms and optimised defrost control
- 8 preloaded applications
- Defrost at single / double evaporator
- Frame Heater
- Local network auto-configuration
- Direct load connection (up to 2 HP)
- Supply voltage control LVD
- Presence of an open collector output



KDEPLUS BUTTONS

The KDEPlus keyboard has 4 keys, as shown in the illustration:



Key Functions:

- 2 ON/OFF regulators for HOT/COLD
- Single defrost and double evaporator
(heatings, modulated heaters, reverse cycle, hot gas)
- Evaporator fans and condenser fans
- Frame Heater
- AUX
- Light
- Door switch
- ON /OFF
- Deep cooling cycle
- Day / Night
- Diagnostics
- “Easy Map” programming
- Programmable inputs/outputs
- LINK2 local area network
- RS485 communication protocol: Modbus
- Compatible with Device Manager (DM)
- Compatible with Unicard and Multi-function key

TECHNICAL DATA

Classification:	electronic automatic control (not safety) device for incorporation
Mounting:	panel mounting
Type of action:	1.B
Pollution class:	2
Material class:	IIIa
Overvoltage category:	II
Nominal pulse voltage:	2500V
Temperature:	Use: -5 ... +55°C - Storage: -30 ... +85°C
Power supply:	SMPS 100-240Va ±10% 50/60 Hz
Power consumption:	5.5W max
Fire resistance category:	D
Software class:	A
RTC battery life:	In absence of external power, the clock battery will last 3 years.

FURTHER INFORMATION

INPUT CHARACTERISTICS

Measurement range:	NTC: -50.0°C ... +110°C; PTC: -55.0°C ... +150°C; PT1000: -60.0°C ... +150°C (on 3-digit display with +/- sign)
Accuracy:	±1.0° for temperatures below -30°C ±0.5° for temperatures between -30°C and +25°C ±1.0° for temperatures above +25°C
Resolution:	1 or 0.1°C
Buzzer:	NO
Analogue/Digital Inputs:	5 configurable NTC/PTC/PT1000/DI inputs 1 multi-function, voltage-free digital input (D.I.)

OUTPUT CHARACTERISTICS

Digital Outputs:	OUT1: 1 SPST relay: 2HP max 240V~
	OUT2: 1 SPDT relay: 1HP max 250V~
	OUT3: 1 SPDT relay: 8(4)A max 250V~
	OUT4: 1 SPST relay: 8(4)A max 250V~
OC (Open Collector) Output:	OC: 1 multifunctional output: 12V \approx 20mA

MECHANICAL CHARACTERISTICS

Dimensions:	121x92 mm
Terminals:	faston and screw for wires with cross-section of 2.5mm ²
Connectors:	TTL for Unicard / Device Manager connection (via DMI)
Humidity:	Usage / Storage: 10...90% RH (non-condensing)

REGULATIONS

Electromagnetic compatibility:	The device complies with Directive 2004/108/EC
Safety:	The device complies with Directive 2006/95/EC
Food Safety:	The device complies with standard EN13485 as follows: <ul style="list-style-type: none"> • Suitable for storage. • Application: air. • Climate range A • measurement class 1 in the range from -25°C to 15°C (*)

(* **with Eliwell probes only**)

NOTE: The technical specifications stated in this document regarding measurement (range, accuracy, resolution, etc.) refer to the instrument alone and not to any accessories provided, such as the probes. This means, for example, that the error introduced by the probe must be added to the error of the instrument.

CONNECTIONS

TERMINALS

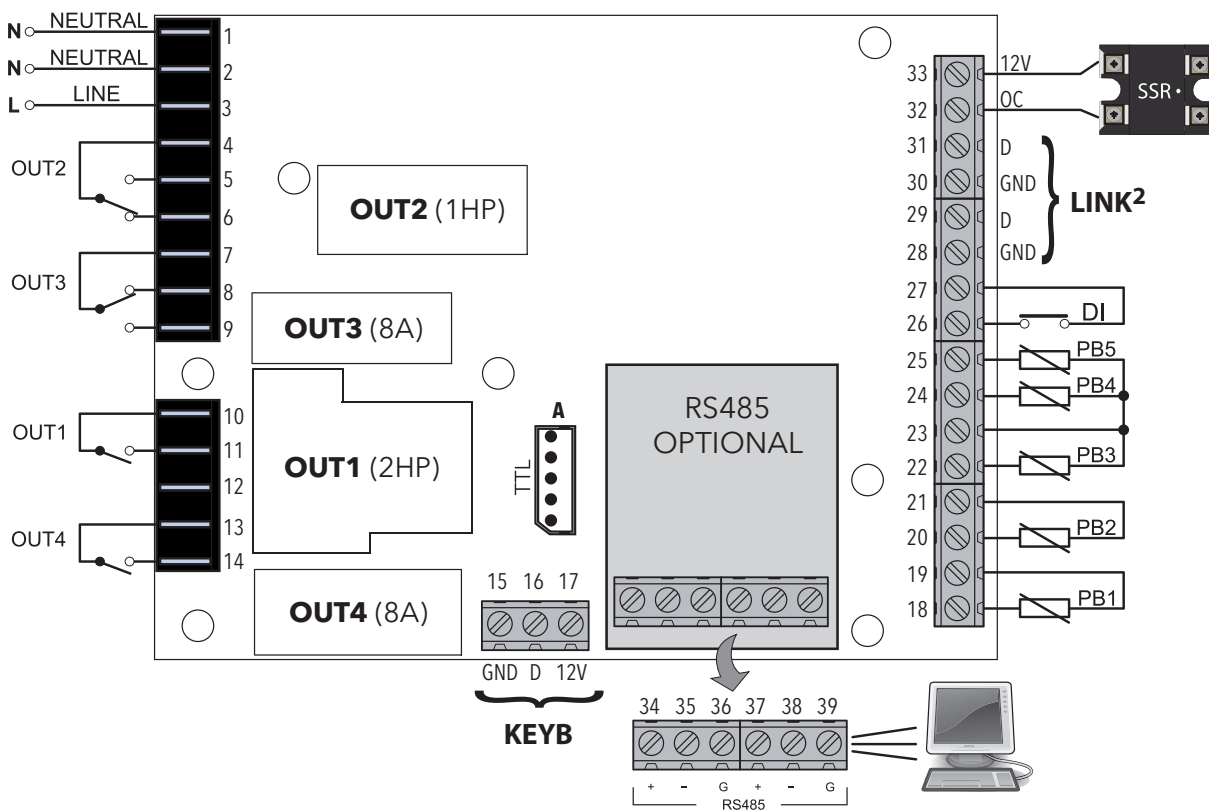

* **N.B.:** analogue inputs PB1...PB5 can also be configured as Digital Inputs DI.

TERMINALS		
1-2	NEUTRAL. These are power supply terminals.	15-16-17 Connection to KDEPlus or KDWPlus external keyboard or ECPlus echo module.
3	LINE. These are power supply terminals.	19-18 PB1 probe connection.
4	OUT2 Shared Terminal	21-20 PB2 probe connection.
5	N.O. OUT2	23-22 PB3 probe connection.
6	N.C. OUT2	23-24 PB4 probe connection.
7	OUT3 Shared Terminal	23-25 PB5 probe connection.
8	N.C. OUT3	27-26 Digital input (DI).
9	N.O. OUT3	28-29 LINK ² . Connection 1 - local area network.
10	OUT1 Shared Terminal	30-31 LINK ² . Connection 2 - local area network.
11	N.O. OUT1	32-33 Open Collector Output (OC).
12	Not Used	A TTL Unicard/DMI/Multi Function Key connection
13	OUT4 Shared Terminal	34-35-36 RS485. Connection 1 - Supervision Gateway.
14	N.O. OUT4	37-38-39 RS485. Connection 2 - Supervision Gateway.

LED

RTN400 family controllers will also function even if a keyboard has not been connected.

With **KDEPlus** or **KDWPlus** keyboards (which are the same and guarantee the same functions), the display will be as follows:

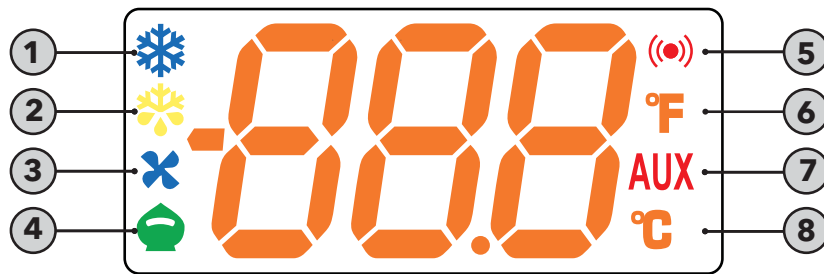

Meaning of LEDs:

No	Icon	LED	Operation	Meaning
1		Compressor	Permanently on	compressor on
			Blinking	Delay, protection or start-up blocked
			OFF	otherwise
2		Defrost	Permanently on	Defrost active
			Blinking	Activated manually or from Digital Input
			OFF	otherwise
3		Fans	Permanently on	Fans active
			OFF	otherwise
4		Reduced SET / Economy	Permanently on	Energy Saving active
			Blinking	Reduced setpoint active
			OFF	otherwise
5		Alarm	Permanently on	alarm active
			Blinking	Alarm acknowledged
			OFF	otherwise
6		°F readout	Permanently on	°F setting (dro = 1)
			OFF	otherwise
7		AUX	Permanently on	Aux output active and/or light on
			Blinking	Deep cooling on
			OFF	otherwise
8		°C readout	Permanently on	°C setting (dro = 0)
			OFF	otherwise

N.B.: When the instrument is powered on it performs a lamp test, during which time the display and LEDs will flash for several seconds to check that they all function correctly.

KDEPLUS BUTTONS

The **KDEPlus** keyboard has 4 keys, as shown in the illustration:







Each key has a different function depending on whether it is:

- Pressed and released
- Pressed for at least 5 seconds
- Pressed and held at start-up
- Pressed in combination with another key.

KEYS

The following table summarizes the function of each key:

No	Key	Action		
		Pressed and released	Press for at least 5 secs	Start-up
1		<ul style="list-style-type: none"> • Scrolls through menu items • Decreases values 	Activates the Manual Defrost function (from outside menus).	---
2		<ul style="list-style-type: none"> • Scrolls through menu items • Decreases values 	Function can be configured by the user (from outside menus). (see parameter H32)	---
3		<ul style="list-style-type: none"> • Returns to the previous menu level • Confirms parameter value 	Activates the Stand-by function (from outside menus).	---
4		<ul style="list-style-type: none"> • Displays any alarms (if active) • Opens Machine Status menu • Confirms commands 	Opens the Programming Menu (User and Installer parameters)	When pressed during start-up it enables the user to select the application to be loaded.

SETPOINT: SETTING AND EDIT LOCK

To display the Setpoint value, press the **set** key to enter the "Machine Status" menu, then press the **set** key again when the "SEt" label is displayed.

The Setpoint value appears on the display. To change the Setpoint value, press the **UP** and **DOWN** keys within 15 seconds. Press **set** to confirm the modification.

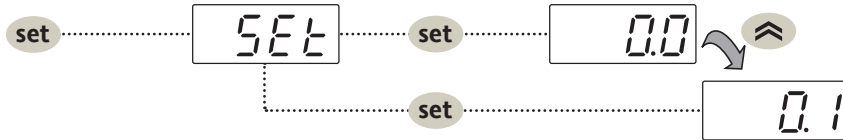

It is possible to disable the keypad on this device.

The keypad can be locked by programming the "LOC" parameter appropriately.

With the keypad locked, you can still access the "Machine Status" menu by pressing **set** to display the Setpoint, but you cannot edit it. To disable the keypad lock, repeat the locking procedure.

DISPLAY PROBES VALUE

To display the value read by probes connected to the device, press the **set** key and enter the "Machine Status" menu, then press the key again when one of the probe-related labels "Pb1...Pb5" press the **set** key again. The value measured by the associated probe will appear on the display.

NOTE: The displayed value is read-only and cannot be modified.

KDEPLUS BUTTONS

The KDEPlus keyboard has 4 keys, as shown in the illustration:



KEY-ACTIVATED FUNCTIONS

All models have the **UP** key set to enable the "Manual Defrost" function.

The DOWN and ESC keys can also be set to activate any other function required by the user.

The parameters for configuring the two keys are:

- **H11** = DOWN key configuration
- **H33** = ESC key configuration

The values that can be set apply to both keys and the functions that can be activated are:

H32/H33 value	Function to enable
0	disabled
1	defrost
2	reduced set
3	Light
4	Energy saving
5	AUX
6	Stand-by
7	Deep cooling cycle
8	Start/end defrost

Sensor to Control Configuration

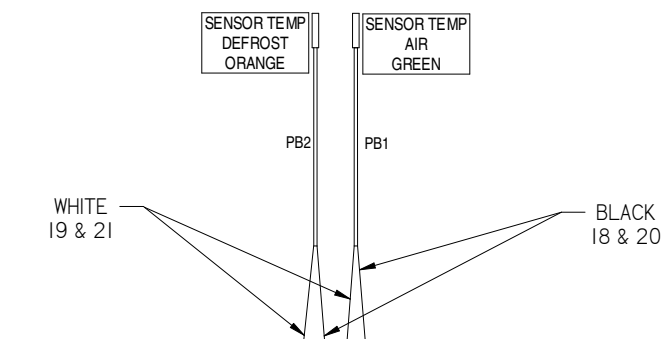

Rear of Control

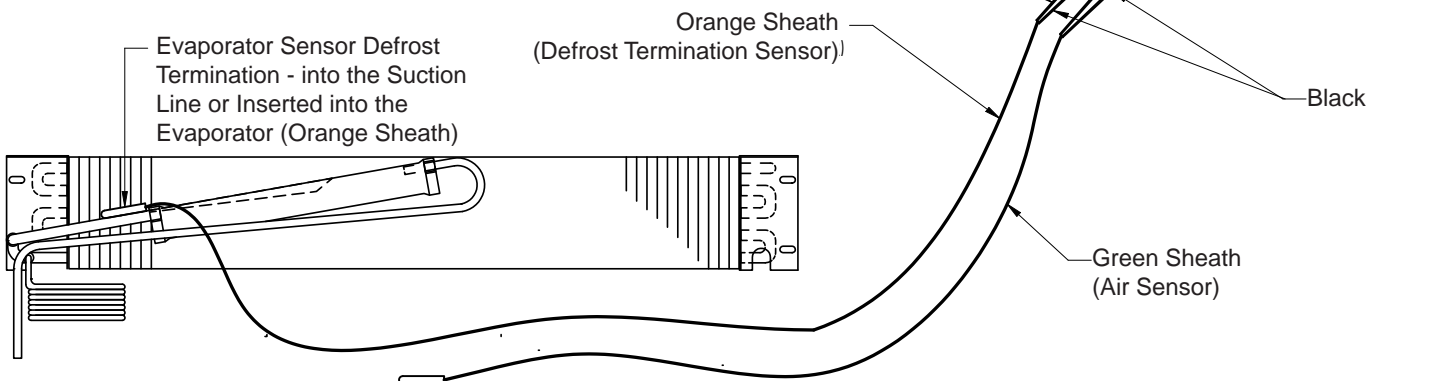
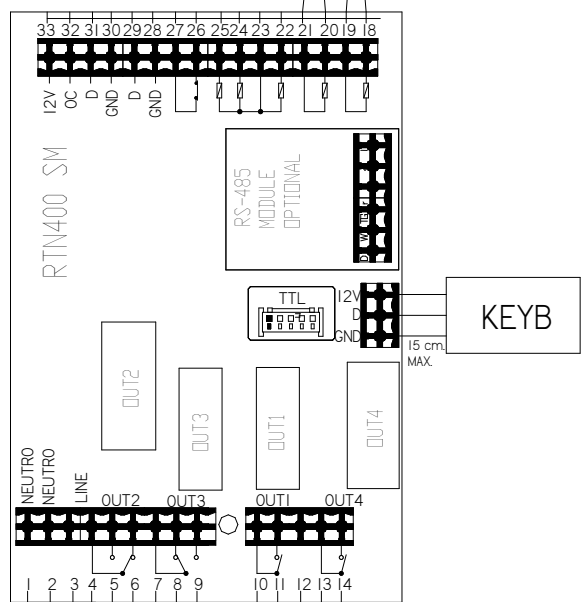

CONTROLS and ADJUSTMENTS

Refrigeration Controls			Defrost Controls			
Model	Product Application	Discharge Air Temperature	Defrost Frequency (per day)	Type of Defrost	Temp. Termination	Failsafe Time (Minutes)
SHM Self Contained	Medium Temp. (Dairy, Deli)	32° F- 38° F	3	Off Time	48° F	45

The Controller controls refrigeration temperature. This is factory installed in the control panel. Adjust the control to maintain the discharge air temperature shown. Measure discharge air temperatures at the center of the discharge honeycomb.

Defrosts are time initiated and temperature terminated. The defrost setting is factory set as shown above.

To ensure a thorough defrost, defrost must be terminated by the temperature termination setting — not by time.

START UP

Follow the start up procedures as detailed in Section 3 of this manual. A thorough inspection should be made prior to start up to ensure there are no loose nuts, bolts, electrical connections or refrigeration lines rubbing or chaffing.

Turn the power switch to the ON position. Allow the system to reach normal operating temperature prior to loading any product. The merchandiser cabinet has a forced air curtain that flows over the top of the product. Air flows out of the honeycomb diffuser, across the product, and into the return air duct.

LOAD LIMITS

Each merchandiser has a load limit decal. Shelf life of perishables will be short if load limit is violated.



AT NO TIME SHOULD MERCHANDISERS BE STOCKED BEYOND THE LOAD LIMITS INDICATED.

DO NOT BLOCK HONEYCOMB OR RETURN AIR GRILLE.

STOCKING

Product should NOT be placed inside the merchandisers until merchandisers are at proper operating temperature.

Allow merchandiser 24 hours to operate before loading product.

WARNING

Product will be degraded and may spoil if allowed to sit in a non-refrigerated area.

Proper rotation of product during stocking is necessary to prevent product loss. Always bring the oldest product to the front and set the newest to the back.

AIR DISCHARGE AND RETURN FLUES MUST REMAIN OPEN AND FREE OF OBSTRUCTION AT ALL TIMES to provide proper refrigeration and air curtain performance. Do not allow product, packages, signs, etc. to block these grilles. Do not use non-approved shelving, baskets, display racks, or any accessory that could hamper air curtain performance.

Do not allow product to be placed outside of the designated load limits in the illustration.

THERMOMETER

A solar powered thermometer is provided with each merchandiser. Temperature display in Fahrenheit degrees is standard. Celsius display is available as an option. The thermometer is located in the cabinet interior in the top left hand rear corner.

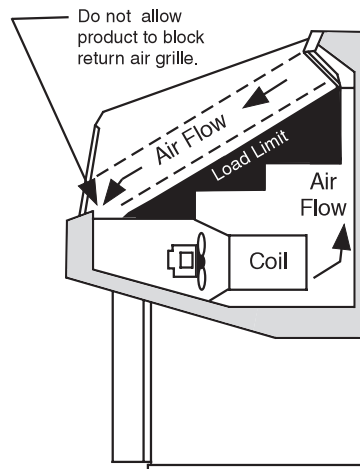

MAINTENANCE

CARE AND CLEANING

Long life and satisfactory performance of any equipment is dependent upon the care it receives. To ensure long life, proper sanitation and minimum maintenance costs, these merchandisers should be thoroughly cleaned, all debris removed and the interiors washed down, weekly.

Exterior Surfaces

The exterior surfaces must be cleaned with a mild detergent and warm water to protect and maintain their attractive finish. **NEVER USE ABRASIVE CLEANSERS OR SCOURING PADS.**

Interior Surfaces

The interior surfaces may be cleaned with most domestic detergents, ammonia based cleaners and sanitizing solutions with no harm to the surface. Self contained models empty into a limited capacity evaporation pan, which will overflow if excess water is used in cleaning.

Do NOT Use:

- Abrasive cleansers and scouring pads, as these will mar the finish.
- Coarse paper towels on coated glass.
- Ammonia-based cleaners on acrylic parts.
- Solvent, oil or acidic based cleaners on any interior surfaces.
- Do not use high pressure water hoses.

WARNING

Product will be degraded and may spoil if allowed to sit in a non-refrigerated area.

Do:

- Remove the product and all loose debris to avoid clogging the waste outlet.
- Store product in a refrigerated area such as a cooler. Remove only as much product as can be taken to the cooler in a timely manner.
- Disconnect electrical power before cleaning.**
- Thoroughly clean all surfaces with soap and hot water. **DO NOT USE STEAM OR HIGH WATER PRESSURE HOSES TO WASH THE INTERIOR. THESE WILL DESTROY THE MERCHANDISERS' SEALING CAUSING LEAKS AND POOR PERFORMANCE.**
- Lift hinged fan plenum for cleaning. Hook chain in rear panel to secure plenum during cleaning. **BE SURE TO REPOSITION THE FAN PLENUM AFTER CLEANING MERCHANDISER.**
- Take care to minimize direct contact between fan motors and cleaning or rinse water.
- Do NOT flood merchandiser with water.

WARNING

Do NOT allow cleaning agent or cloth to contact food product.

NEVER INTRODUCE WATER FASTER THAN THE WASTE OUTLET CAN REMOVE IT.

SELF CONTAINED MODELS EMPTY INTO AN EVAPORATION PAN THAT WILL OVERFLOW IF TOO MUCH WATER IS INTRODUCED DURING CLEANING.

- Allow merchandisers to dry before resuming operation.
- After cleaning is completed, turn on power to the merchandiser.

WARNING

— LOCK OUT / TAG OUT —

To avoid serious injury or death from electrical shock, always disconnect the electrical power at the main disconnect when servicing or replacing any electrical component. This includes, but is not limited to, such items as doors, lights, fans, heaters, and thermostats.

CLEANING DISCHARGE HONEYCOMB

Discharge honeycombs should be cleaned every six months. Dirty honeycombs will cause merchandisers to perform poorly. The honeycombs may be cleaned with a vacuum cleaner. Soap and water may be used if all water is removed from the honeycomb cells before replacing. Be careful not to damage the honeycomb.

1. Using a flat object such as a screw driver, compress the honeycomb and remove it from its retainer.
2. Clean and dry the honeycomb.
3. After cleaning, replace in reverse order. Damaged honeycomb must be replaced.

CAUTION

DO NOT FLOOD!

Use only enough water necessary to clean surface. Water must not drip down the case!

Never use ammonia based cleansers, abrasive cleansers, or scouring pads.

CLEANING STAINLESS STEEL SURFACES

Use non-abrasive cleaning materials, and always polish with grain of the steel. Use warm water or add a mild detergent to the water and apply with a cloth. Always wipe rails dry after wetting.

Use alkaline chlorinated or non-chlorine containing cleaners such as window cleaners and mild detergents. Do not use cleaners containing salts as this may cause pitting and rusting of the stainless steel finish. Do not use bleach.

CLEANING UNDER STEP PAN

Remove all product from the merchandiser and place in cooler. Always disconnect electrical power before cleaning.

1. Place a small screw driver between the front grille and step pan. Gently lift the step pan's front lip up. Grasp the step pan with both hands to remove. Always wear gloves when removing step pan.
2. Use non-abrasive cleaning materials and a mild detergent to clean the step pan.
3. Wipe down the insides of the merchandiser with a mild detergent, and replace step pan.

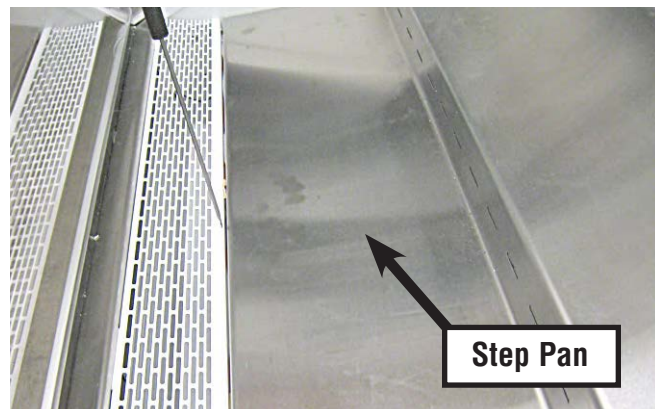

CLEANING THERMOMETER

Remove the two screws holding the thermometer to its mounting bracket. Remove the sensing element from its clip. Clean the element with water and mild detergent solution. Ensure the sensing element is wiped clean of any residue to ensure proper temperature readings.

WARNING

Do NOT use HOT water on Cold glass Surfaces. This can cause the glass to shatter and could result in personal injury. Allow glass fronts, to warm before applying hot water.

CLEANING COILS

Condenser coils should be cleaned at least once per month. Additional cleaning may be needed depending on the operational environment. A dirty condenser blocks normal airflow through the coils.

NEVER USE SHARP OBJECTS AROUND COILS. Use a soft brush or vacuum brush to clean debris from coils. ***Do not puncture coils!*** Do not bend fins. Contact an authorized service technician if a coil is punctured, cracked, or otherwise damaged.

ICE in or on the coil indicates the refrigeration and defrost cycle is not operating properly. Contact an authorized service technician to determine the cause of icing, and to make adjustments as necessary. To maintain product integrity, move all product to a cooler until the unit has returned to normal operating temperatures.

WARNING

SHUT FANS OFF DURING CLEANING PROCESS.

Airflow blockage increases energy consumption and reduces the merchandiser's ability to maintain operating temperature.

To clean the coils, use a vacuum cleaner with a wand attachment and a soft (non-metallic) brush to remove dirt and debris. Do not bend coil fins. Always wear gloves and protective eye wear when cleaning near sharp coil fins and dust particles.



**CLEANING EVAPORATION PAN
(SELF CONTAINED ONLY)**

The condensate water outlet for self contained models empties into a limited capacity evaporation pan.

Debris or dirt accumulation inside the condensate evaporation pan or on the heater coil will reduce the pan’s evaporation capacity and cause premature heater failure. The evaporation pan waste water will overflow and spill onto the floor if the heater is not properly operating.

Remove accumulated debris from the evaporation pan. Wipe down heater coil with a cloth and warm water. Be sure to remove any dirt, debris or liquids from the heater coil.

Water introduced during cleaning will cause the evaporation pan to overflow.

 CAUTION
<p>Evaporation Pan is Hot! and poses risk of bodily injury – Always Wear gloves and protective eye wear when servicing. Turn off evaporation pan heater, and allow pan to cool.</p>

REMOVING SCRATCHES FROM BUMPER

Most scratches and dings can be removed using the following procedure.

1. Use steel wool to smooth out the surface area of the bumper.
2. Clean area.
3. Apply vinyl or car wax and polish surface for a smooth glossy finish.

**MAINTAINING FLUORESCENT LAMPS
(FOR OPTIONAL LIGHT BAR KIT)**

Fluorescent lamps should not be allowed to run to failure. If a re-lamp schedule is not in place, the tubes should be inspected for signs of degradation (blackened ends). Degraded or failed tubes should be replaced.

Allowing severely degraded lamps to operate may cause a ballast failure or could expose the lamp holder to excessive heat. Replacing degraded bulbs is more cost effective than replacing ballast and lamp-holders. Traditional re-lamp programs are 18-to-24 month intervals. In the absence of a re-lamp program, a yearly inspection of the lighting system is recommended.

1. Inspect all lamp sockets and plug-receptacle connections for signs of arching. Replace any component that shows signs of arching.
2. Make sure all unused receptacles have their close-off covers securely installed.
3. Make sure proper cleaning procedures are followed. Lights and fans **MUST** be turned off when a case is cleaned and **MUST** be allowed to dry before turning power back on.
4. Do not use a pressure nozzle to clean inside of case.

<p>PRECAUTION CLEANING PRECAUTIONS</p>
<p>When Cleaning:</p> <ul style="list-style-type: none"> • Do not use high pressure water hoses • Do not introduce water faster than waste outlet can drain • NEVER INTRODUCE WATER ON SELF CONTAINED UNIT WITH AN EVAPORATION PAN • NEVER USE A CLEANING OR SANITIZING SOLUTION THAT HAS OIL BASE (these will dissolve the butyl sealants) or an AMMONIA BASE (this will corrode the copper components of the merchandiser) • TO PRESERVE THE ATTRACTIVE FINISH: <ul style="list-style-type: none"> • Use a water and a mild detergent for the exterior only • Do NOT use a chlorinated cleaner on any surface • Do NOT use abrasives or steel wool scouring pads (these will mar the finish)

Self-Contained Refrigeration Equipment Maintenance Check List

***** Warranty does not cover issues caused by improper installation or lack of basic preventative maintenance. *****	
Record starting date	
Store Name and Number	
Store Address	
Unit Model Number	
Unit Serial Number	
Contractor/Technician	

	Technician									
	PM date									
PM activity - For visual inspection items, denote "ok or complete" in the column to right when PM has been performed. For measured data requested, record data requested in the appropriate column to the right	Quarterly	Semi-Annually	Q1	Q2	Q3	Q4	Q1	Q2	Q3	Q4
Check in with store manager, record any complaints or issues they have with unit.	X									
Look unit over for any damage, vibrations or abnormal noise.	X									
Verify unit is level side to side and front to rear.	X									
Confirm refrigerant lines properly are secured and not touching or rubbing other lines, wires or frame work.	X									
Verify fan motors and motor mounts are tight.	X									
Confirm fan blade/s are tight and not rubbing or hitting.	X									
Make sure all electrical connections, factory and field, are tight.	X									
Verify electrical connections at lamps are they secure and dry.	X									
Check for and replace any frayed or chaffed wiring.	X									
Check all electrical wiring make sure it is secured and not on any sharp edges or hot lines.	X									
Check for air disturbances external to the unit. Heat and air registers, fans, and doors etc.	X									
Check for water leaks.	X									
Clean evaporator coil/s and fan blade/s. Do not use an acid base cleaner. Rinse off any cleaner residue.		X								
Clean discharge air honeycombs or grilles. Do not use an acid base cleaner. Rinse off any cleaner residue.		X								
Clean condenser coil/s and fan blade/s. Do not use an acid base Cleaner. Rinse off any cleaner residue.		X								
Clean condensate drain pan and drain line.		X								
Verify condensate drain lines are clear and functioning.		X								
Record voltage reading at unit with unit off?		X								
Verify condenser and evaporator fans are working.	X									
Record condenser air inlet temperature	X									
Record condenser air outlet temperature	X									
Is condenser air inlet or air exhaust restricted or recirculating?	X									
Verify there are no visual oil or refrigerant leaks.	X									
Record voltage reading with unit running.		X								
Record compressor amp draw.		X								
Record defrost heater voltage and amp draw.		X								
Record anti-sweat heater voltage and amp draw.		X								
Record case product temperature.	X									
Record unit discharge air temperature.	X									
Record unit return air temperature.	X									
Record ambient conditions around unit (wet Bulb temperature and dry bulb temperature).	X									
Check product loading, do not load beyond the units load limits.	X									
Verify clearances on sides/back of unit.	X									
Check unit controller for proper operation. See controller or 1/0 Manual for proper controller operation.		X								
Confirm door switches function.	X									
Verify unit doors and lids work and are sealed correctly.	X									
Verify that all the panels, shields and covers are in place.	X									

Technician Notes:

SERVICE

REPLACING FAN MOTORS AND BLADES

Should it ever be necessary to service or replace the fan motors or blades be certain that the fan blades are reinstalled correctly. **THE BLADES MUST BE INSTALLED WITH RAISED EMBOSING (PART NUMBER ON PLASTIC BLADES) POSITIONED AS INDICATED ON THE PARTS LIST.**

For access to these fans:

1. Remove product and place in a refrigerated area. Disconnect electrical power.
2. Remove bottom step pan.
3. **Disconnect fan from wiring harness.**
4. If it is determined that fan motor needs to be replaced, remove fan motor brackets from the fan plenum as shown.
5. Replace fan motor and/or blades.
6. Install brackets to fan motor and install motor and bracket to the plenum.
7. Reconnect fan motor to wiring harness.
8. Turn on power.
9. Verify that motor is working and blade is turning in the correct direction.
10. Reinstall display pans. Bring merchandiser to operating temperature before restocking.

! WARNING

— LOCK OUT / TAG OUT —

To avoid serious injury or death from electrical shock, always disconnect the electrical power at the main disconnect when servicing or replacing any electrical component. This includes, but is not limited to, such items as doors, lights, fans, heaters, and thermostats.

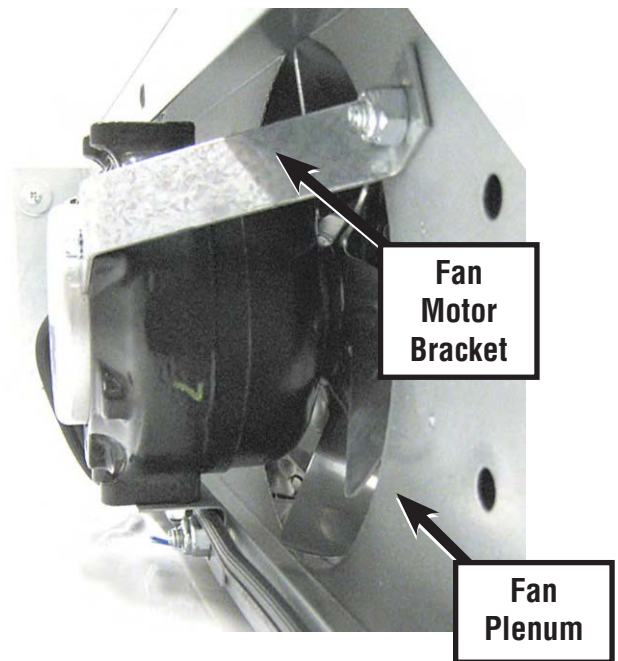

! WARNING

Product will be degraded and may spoil if allowed to sit in a non-refrigerated area.

REPLACING LIGHTS

This section is only valid if the Optional Light Bar is ordered — field installed only.

There is a convenient ON/OFF switch located on the light bar. This switch only controls the lights. ALWAYS disconnect electrical power when replacing lights or lighting parts.

SHM merchandisers are available with optional LED lights. The bulb is sleeved to protect the lights from damage. If these bulbs need to be replaced, slide the prongs clear of the lamp holder. Ensure that the prongs on the replacement bulb twist and lock into place.

REPLACING BALLAST / POWER SUPPLY

LED fixture replacement follows the same steps as fluorescent bulbs. However, LED fixtures have the sleeve built in as a single assembly. The LED power supply is located in the electrical box of the light bar kit.



WARNING

Fluorescent lamps contain mercury vapor. Mercury exposure at high levels can harm the brain, heart, kidneys, lungs, and immune system of people of all ages. Do not break or puncture fluorescent lamps. Dispose of, or store, all fluorescent lamps in accordance with Federal (40 CFR 273), State, and local hazardous waste requirements. Refer to:
<http://www.epa.gov/mercury/about.htm>

Replacement Parts List

Models		SHM-3	SHM-4
Standard Parts			
Description	Part Number		
Evaporator Fan Motor	21S073	X	X
Evaporator Fan Blade	0519568	X	X
Evaporator Fan Motor Bracket Top	910070	X	X
Evaporator Fan Motor Bracket Bottom	910060	X	X
Sensor NTC 4 mts Green	3023554	X	X
Sensor NTC 4 mts Orange	3031571	X	X
Control Eliwell RTN400	3023537	X	X
Control Display KDE	3023552	X	X
Display cable 5 meter	3023553	X	X
Compressor Relay (T92P7A22-120)	0459304	X	X
Power Switch	03S422	X	X
Solar Thermometer	05S521	X	X
Evaporator Fan Harness	19S512	X	X
Side Plexiglass Ends	29S895	X	X
Front Plexiglass	29S8941	X	
Front Plexiglass	29S8942		X
Leg Leveler	35S024	X	X
Black rubber Drain Hose (32")	18S063	X	X
Night Curtain (3') w/snap KIT 293681	35S074	X	
Night Curtain (4') w/snap KIT 293682	35S066		X
Front Bumper End Cap (Black)	18S2932	X	X
Honeycomb (white)	29S6821	X	
Honeycomb (black) KIT OU15	29S6821B	X	
Honeycomb (white)	29S6822		X
Honeycomb (black) KIT OU16	29S6822B		X
Power Cord NEMA 5-15P	19S216	X	X
Stainless Steel 3-Step Shelf	290841	X	
Stainless Steel 3-Step Shelf	290842		X
Stainless Steel Shelf Back Step Shelf	290771	X	
Floater Relay SPDT NC 120V	0342598	X	
Floater M8000	1804342	X	
Floater Nut NPT 1/8-27	1006201	X	

Replacement Parts List (Continued)

Models		SHM-3	SHM-4
Refrigeration			
Description	Part Number		
Condensing Unit Assy (404a)	294690	X	
Condensing Unit (Purchased) M4FH-0038-IAA	02S618	X	
Condensing Unit Assy (134A)	291922		X
Condensing Unit (Purchased) AKA4457YAADS 2G222-69	3010158		X
Drier (C052-S)	17S362	X	X
Pull out Coil assy	294660	X	
Pull out Coil assy	3010656		X
Assembly Evaporator Coil	294710	X	
Assembly Evaporator Coil	291932		X
Cap Tube Assembly	294630	X	
Cap Tube Assembly	292360		X
Evaporator Coil	26S102	X	
Evaporator Coil	26S119		X
Accumulator	17S098	X	X

Models		SHM-3	SHM-4
Condensate Pan			
Description	Part Number		
Electric Condensate Pan Assy (350W)	292540		X
Electric Condensate Pan Assy (350W)	3038082	X	
Condensate Pan (only)	292530		X
Condensate Pan (only)	3038083	X	
Condensate Pan Heater (350W)	19S678	X	X

Replacement Parts List (Continued)

Models		SHM-3	SHM-4
Sheel Metal Replacement Parts Painted			
Description	Part Number		
Front Louvered Access Panel w/Display KO	291431	X	
Front Louvered Access Panel w/Display KO	291432		X
Panel Top Front-White (Painted Exterior Color of Case)	290681	X	
Panel Top Front-White (Painted Exterior Color of Case)	290682		X
Front LH Glass Brkt Assy (Metallic Silver)	294851	X	X
Front RH Glass Brkt Assy (Metallic Silver)	294852	X	X
Front Glass Bracket (Metallic Silver)	290671	X	
Front Glass Bracket (Metallic Silver)	290672		X
Rear lower Panel-White (Bumper area)	290731	X	
Rear lower Panel-White (Bumper area)	290732		X
Bottom Air Grille (Painted Interior Color of Case)	290831	X	
Bottom Air Grille (Painted Interior Color of Case)	290832		X
Arm Trim Alum LH (Painted Exterior Color of Case)	30S8662	X	X
Arm Trim Alum RH (Painted Exterior Color of Case)	30S8661	X	X
Solar Thermometer Bracket (White or Black)	292410	X	X

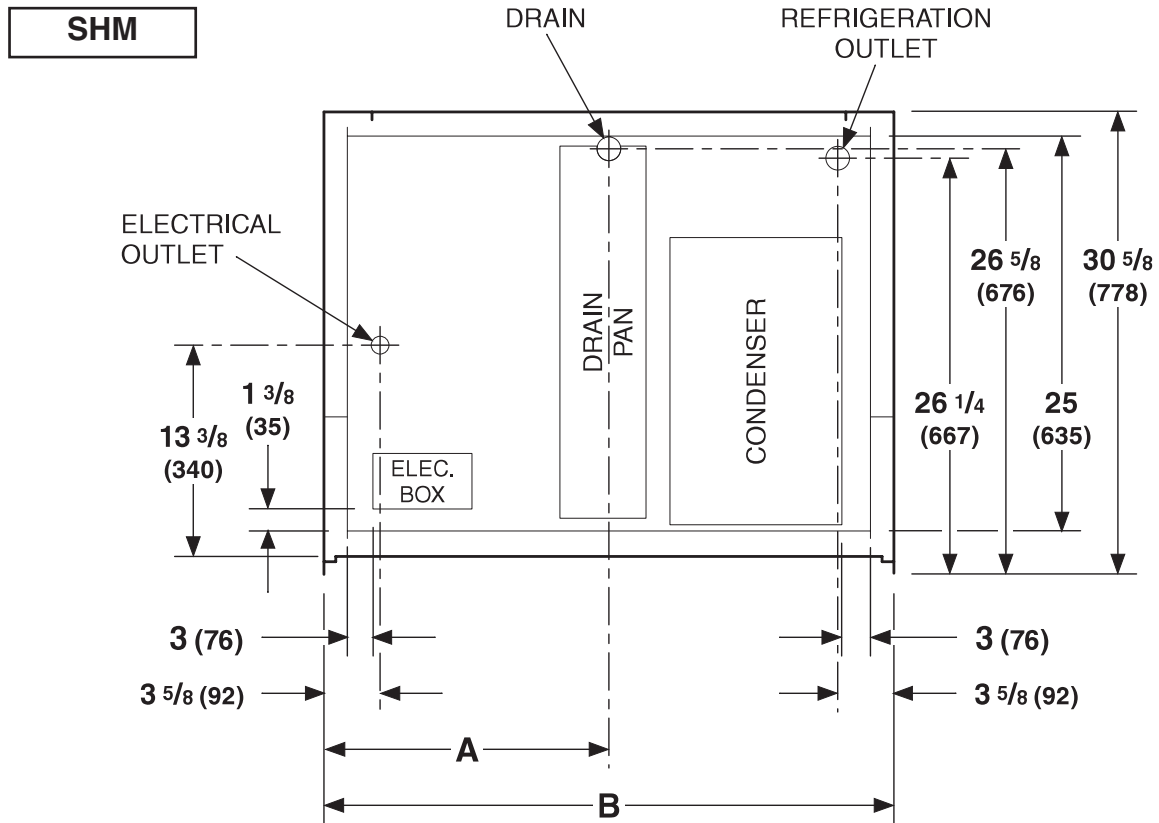

MODEL	"A"	"B"
SHM300	18"	36"
SHM400	24"	48"

General

Case Length (<i>Note: Includes One Pair Ends</i>)	5ft (68 3/8) (1737)	10ft (3353)
Optional End Bumpers (<i>One Pair</i>)	2 (51)	2 (51)
Maximum O/S dimension of case back to front (<i>Note: Includes bumper</i>)	43 1/2 (1105)	87 (2210)
Width of skid rail	9 5/8 (244)	19 1/4 (488)

Waste Outlet

LH end of case (<i>from outside of End Assembly</i>) to center of waste outlet	33 1/2 (851)	67 (1702)
---	--------------	-----------

Dimensions shown as inches and (mm).

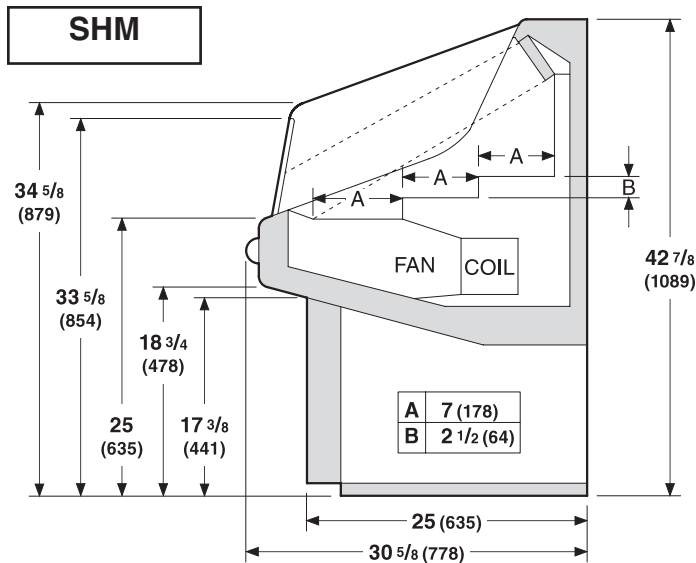

REFRIGERATION DATA

Note: This data is based on store temperature and humidity that does not exceed 80°F and 55% R.H. unless otherwise stated. Schedule defrost at night while lights are off.

	SHM	
	SHM-3	SHM-4
Condensing Unit (hp)	1/3	1/2
Condensing Unit Capacity (Btu/hr at std. rating conditions)	2300	3535

DEFROST DATA

Frequency (hr)	8
OFFTIME	
Failsafe (minutes)	45
Defrost Termination Temperature	48°F

PHYSICAL DATA

Refrigerant Charge

SHM-3	R404A	27.6 oz	0.782 kg
SHM-4	R-134A	30 oz	0.85 kg

Electrical Data

Note: These are rated values for individual components and should not be added together to determine total merchandiser electrical load.

	SHM-3		SHM-4	
Number of Fans – 5W	2		2	
	Amperes	Watts	Amperes	Watts
Evaporator Fans				
115V 60Hz Standard	0.6	10	0.6	10
Condensate Pan Heaters (115V)	8.3	1000	3	350

**Condensing Unit
(208/230V, 1Ph, 60Hz) Standard**

SHM-3	
Compressor LRA	39
Compressor RLA	7.9
SHM-4	
Compressor LRA	48
Compressor RLA	9.5

Product Data

AHRI Total Display Area¹ (Sq Ft/Case)	SHM-3 6.1 ft ² /case (0.584 m ² /case)
	SHM-4 8.1 ft ² /case (0.752 m ² /case)

¹Computed using AHRI 1200 standard methodology:
Total Display Area, ft² [m²] / Unit of Length, ft [m]

	Nominal HP	Refrigerant Type	Volts	Run Amps	Nema Plugs	Fuse Amps	Hz/Ph
SHM-3	1/3	R404a	115	10.3	5-15P	15	60/1
SHM-4	1/2	R134a	115	9.5	5-15P	15	60/1

Requires Field Wiring

ESTIMATED SHIPPING WEIGHT ²

Case	<i>SHM-3</i>	<i>SHM-4</i>	<i>End</i>
lb (kg)	320 (145)	364 (165)	Included

²Actual weights will vary according to optional kits included.

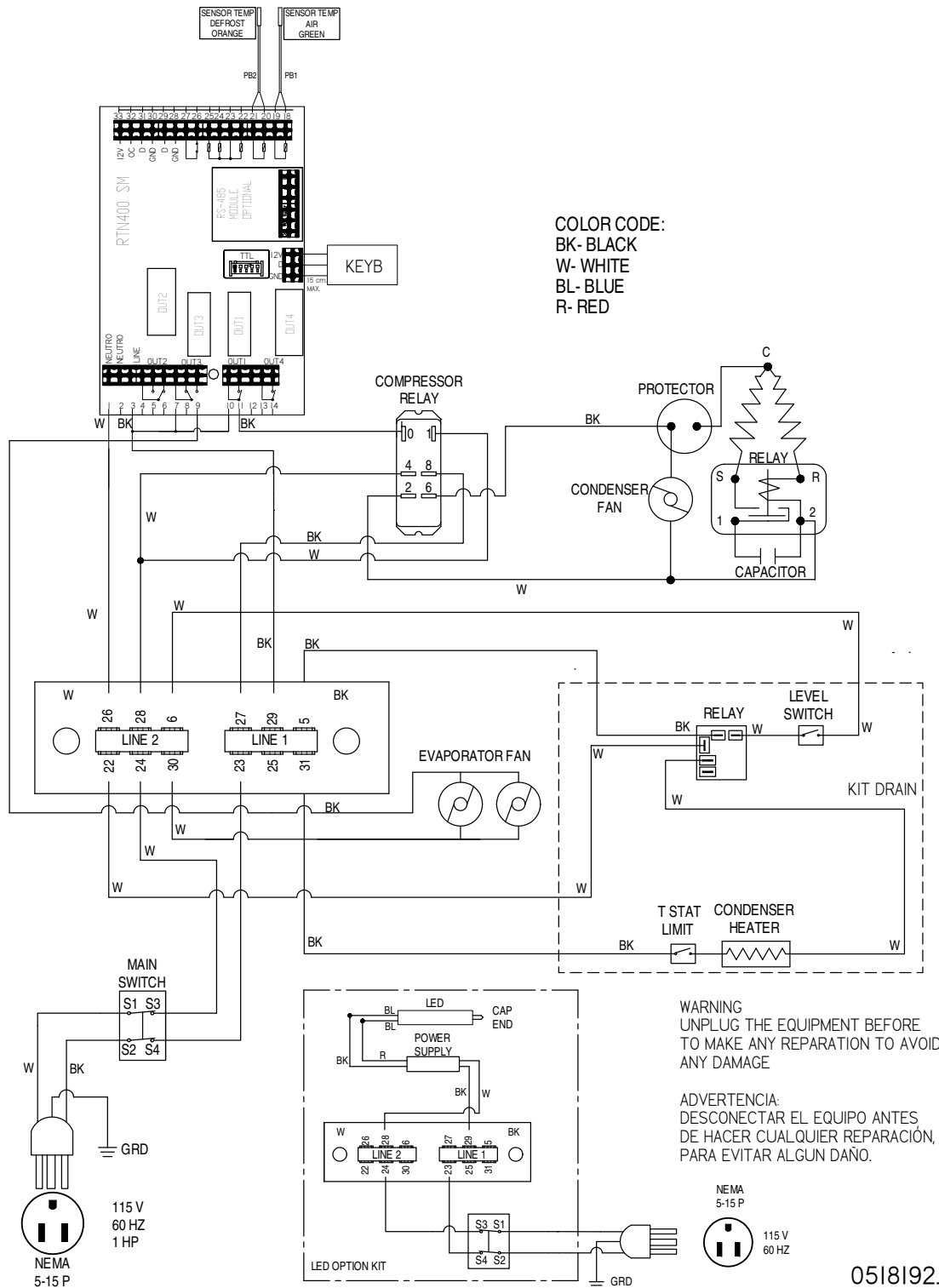

WARNING

All components must have mechanical ground, and the merchandiser must be grounded.

CIRCLED NUMBERS = PARTS LIST ITEM NUMBERS

R = Red Y = Yellow G = Green BL = Blue BK = Black W = White

● = 120V POWER ○ = 120V NEUTRAL ⊥ = FIELD GROUND $\overline{\text{m}}$ = CASE GROUND

SHM-4

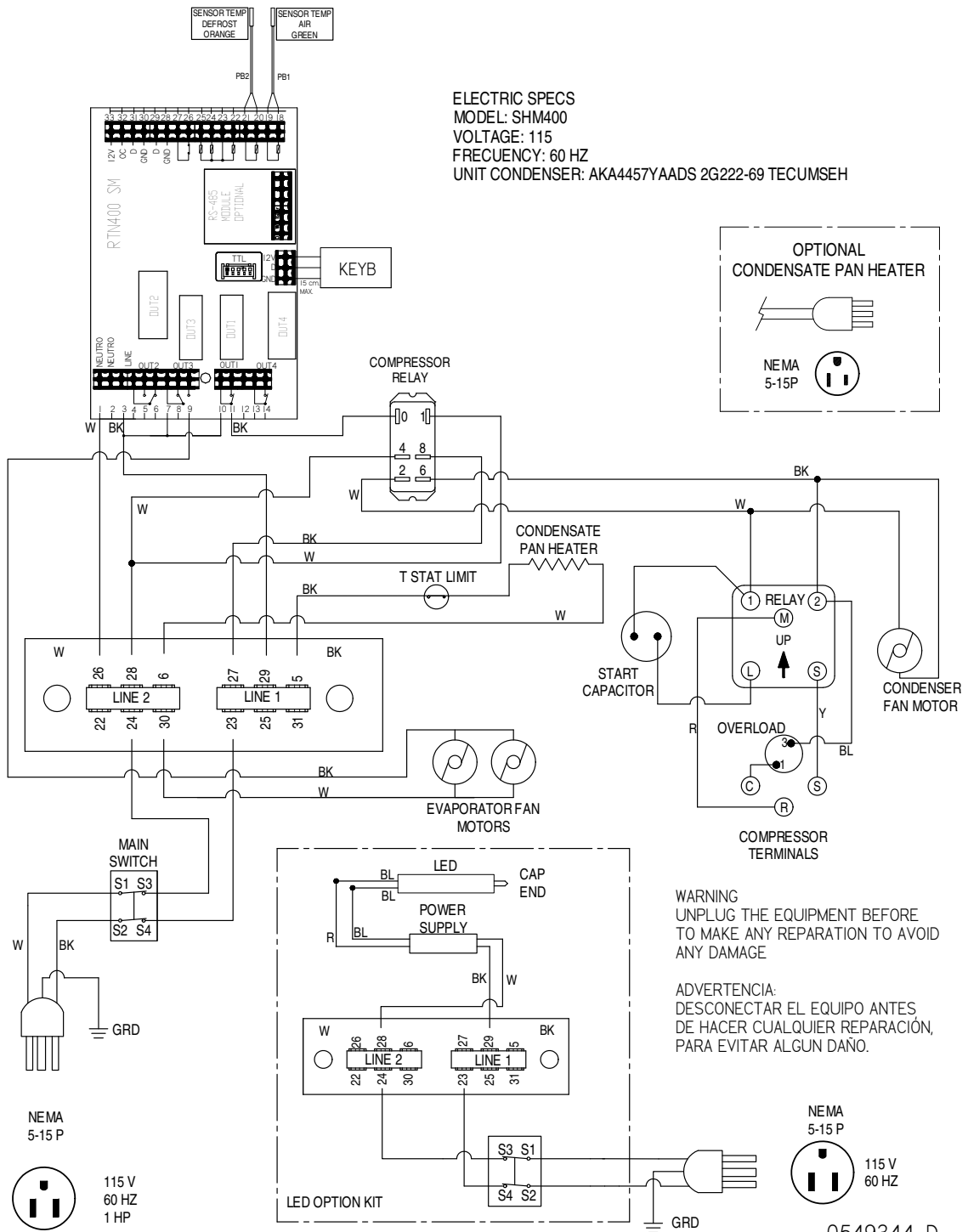

WARNING

All components must have mechanical ground, and the merchandiser must be grounded.

CIRCLED NUMBERS = PARTS LIST ITEM NUMBERS

R = Red Y = Yellow G = Green BL = Blue BK = Black W = White

● = 120V Power ○ = 120V Neutral ⚡ = FIELD GROUND $\overline{\text{m}}$ = CASE GROUND



HUSSMANN[®]

**To obtain warranty information
or other support, contact your
Hussmann representative.
Please include the model and
serial number of the product.**

Hussmann Corporation, Corporate Headquarters: Bridgeton, Missouri, U.S.A. 63044-2483 01 October 2012