

HUSSmann®



Freedom Line

Meat, Delicatessen, Dairy and Produce
Merchandisers
Compressor Ready



Installation & Operation Manual

Shipped With Case Technical Data Sheets

P/N 0527427_M

Excel Series

September 2018

IMPORTANT

**Keep in store for
future reference!**

Spanish 0532380

French 0532381

TABLE OF CONTENTS

<p>INSTALLATION TOOL LIST iv</p> <p>ANSI Z535.5 DEFINITIONS iv</p> <p>INSTALLATION</p> <p>UL Listing 1-1</p> <p>Federal / State Regulations 1-1</p> <p>Location 1-1</p> <p>Freedom Line Description 1-1</p> <p>Shipping Damage 1-2</p> <p style="padding-left: 20px;">Apparent Loss or Damage 1-2</p> <p style="padding-left: 20px;">Concealed Loss or Damage 1-2</p> <p>Unloading 1-2</p> <p>Serial Plate Location 1-2</p> <p>Exterior Loading 1-2</p> <p>Merchandisers Shipped with End Installed 1-3</p> <p>Moving Merchandisers into Position 1-3</p> <p>Shipping Braces 1-3</p> <p>Shipping Rider 1-3</p> <p>Merchandiser Leveling 1-4</p> <p>Joining Instructions 1-6</p> <p style="padding-left: 20px;">Preparation 1-6</p> <p style="padding-left: 20px;">Apply Gaskets 1-7</p> <p style="padding-left: 20px;">Align End Frames 1-8</p> <p style="padding-left: 20px;">Fasten Canopies 1-12</p> <p style="padding-left: 20px;">Fasten End Frames 1-12</p> <p style="padding-left: 20px;">Tighten End Frames 1-13</p> <p style="padding-left: 20px;">Seal Merchandiser 1-14</p> <p>Install Splashguard Brackets 1-14</p> <p>Offsetting Bumper 1-14</p> <p>Installing Partitions 1-16</p> <p>Installing End Assemblies 1-16</p> <p>Night Curtain Instructions 1-21</p> <p>REFRIGERATION / ELECTRICAL / CONTROLLER</p> <p>Field Installation of Condensing Unit 2-1</p> <p>About Quick Connect Couplings 2-6</p> <p>Connect Lines 2-6</p> <p>Insulate Refrigerant Lines 2-6</p> <p>(Optional) Condensate Water and Pump 2-8</p> <p>Controller Operation 2-10</p> <p>Controls and Adjustments 2-12</p> <p>Emerson Pressure Control Settings 2-12</p>	<p>Merchandiser Electrical Data 2-13</p> <p>Electrical Connections 2-13</p> <p>Identification of Wiring 2-13</p> <p>Wiring Diagram 12 & 8 ft 2-14</p> <p>Wiring Diagram 6 & 4 ft 2-15</p> <p>Controller Parameters 2-16</p> <p>DRIP PIPING/FACADES/SPLASHGUARDS/BUMPERS</p> <p>Waste Outlet and Water Seal 3-1</p> <p>Installing Drip Piping 3-1</p> <p>Optional Drip Piping Arrangements 3-2</p> <p>Install Facade 3-3</p> <p>Installing Rear Close-Offs 3-5</p> <p>Installing Splashguards 3-6</p> <p>Installing Bumpers 3-7</p> <p>START-UP / OPERATION</p> <p>Start-Up 4-2</p> <p>Stocking 4-2</p> <p>Load Limits 4-2</p> <p>Install Shelves 4-3</p> <p>Multi-Deck Shelf Configuration 4-3</p> <p>Shelf Maximum Weight Limits 4-3</p> <p>Optional Multi-Deck Shelf Alignment Strips 4-4</p> <p>Installing Shelf Lighting 4-5</p> <p>Thermometer 4-7</p> <p>MAINTENANCE</p> <p>Care & Cleaning 5-1</p> <p>Cleaning Mirrors 5-2</p> <p>Cleaning Honeycomb Assemblies 5-3</p> <p>Cleaning Stainless Steel Rails 5-3</p> <p>Removing Interior Back Panels 5-4</p> <p>Cleaning Coils 5-4</p> <p>Cleaning Condensate Pump and Heated Evaporation Pans 5-5</p> <p>Cleaning Under Merchandisers 5-6</p> <p>Removing Scratches from Bumper 5-6</p> <p>Maintaining Fluorescent Lamps 5-6</p>
--	---

IMPORTANT
KEEP IN STORE FOR FUTURE REFERENCE
Quality that sets industry standards!



12999 St. Charles Rock Road • Bridgeton, MO 63044-2483

U.S. & Canada 1-800-922-1919 • Mexico 1-800-890-2900

www.husmann.com

© 2018 Husmann Corporation

SERVICE

Replacing Fan Motors and Blades 6-1
 Replacing LED Canopy Light Bars 6-2
 Replacing LED Shelf Light Bars 6-2
 Replacing LED Power Supplies 6-3
 Replacing Fluorescent Lamps 6-4
 Replacing Lamp Holders and End Caps 6-4
 Replacing Electronic Ballasts 6-4
 Repairing Aluminum Coil 6-6

EMERSON UNIT CONTROL 7-1

SAFE-NET III 8-1
For cases manufactured before September 2017

WARRANTY

**EXCEL INSTALLATION
TOOL LIST**

Unloading From Trailer:

Lever Bar (also known as a Mule,
Johnson Bar, J-bar, Lever Dolly, and pry lever)
Moving Dolly

Setting Case Line-Up:

Level, 4 ft suggested
Ratchet
1/4 in. Socket
5/16 in. Socket
1/2 in. Socket
Battery Drill/Screw Gun
Caulking Gun
10 in. Adjustable Crescent Wrench

ANSI Z535.5 DEFINITIONS



• **DANGER** – Indicate[s] a hazardous situation which, if not avoided, will result in death or serious injury.



• **WARNING** – Indicate[s] a hazardous situation which, if not avoided, could result in death or serious injury.



• **CAUTION** – Indicate[s] a hazardous situation which, if not avoided, could result in minor or moderate injury.

• **NOTICE** – *Not related to personal injury* – Indicates[s] situations, which if not avoided, could result in damage to equipment.

REVISION HISTORY

REVISION M

Night Curtain Instructions Page 1-21
California Warning Updated

REVISION L

Updated to replace Safe-NET III Control with Dixell XR75

REVISION K

Updated Page 1-1, Page- 2-6 removed refrigerant reference.

REVISION J

California Warning, Page 1-1.
Excel Note Page 1-1.
Changed color of Warning Boxes to black.

REVISION H

1. Updated Emerson bulletin at back of manual.
2. Added jumper to wiring diagram 14 to 16, Page 2-20.

REVISION G

1. Added CAUTION box, Pages 1-4 and 4-3.
2. Added Recommended Shelf Depth table, Page 4-5.
3. Added *Maintaining Fluorescent Lamps*, Page 5-6.
4. Revised Fluorescent Canopy Lamps, Page 6-4.

REVISION F

1. Added Emerson Control Setting, page 2-18.
2. Changes Coupling Size Table on page 2-6.
3. Added Emerson Manual after Section 6.

REVISION E

1. Heater and Pump Cleaning Info, Page 5-5.
2. New Condenser Pump Piping
Pages 2-4, 2-5, 2-10.
3. Rear Facade Close-off, Page 3-5.
4. Oil Level, Page 4-2.

REVISION D

1. Condensing Unit Locations, Page 2-2.
2. Condensate Pan Heater Locations, Page 2-4.
3. CF5X/DF5NX Operating Parameters, Page 2-11.
4. Defrost Synchronization Kits (Optional),
Page 2-20.
5. Defrost Sync Wiring, Page 2-21.
6. Defrost Sync Enclosure Construction, Page 2-22.
7. Wiring Diagram, Page 2-23.

REVISION C

1. Added Install Shelves, Page 4-2.
2. Added coil cleaning, Page 5-4.

REVISION B

1. Added GFCI Receptacle, Page 2-14.
2. Changed Defrost Temperature Termination.
3. Air Panel Install with Facade.
4. 20 in. side facade.

REVISION A

1. Revision A is original manual issue.

INSTALLATION

UL LISTING

These merchandisers are manufactured to meet ANSI/ UL 471 standard requirements for safety. Proper installation is required to maintain the listing.

FEDERAL / STATE REGULATION

These merchandisers at the time they are manufactured, meet all federal and state/ provincial regulations. Proper installation is required to ensure these standards are maintained. Near the serial plate, each merchandiser carries a label identifying the environment for which the merchandiser was designed for use.

ANSI/NSF-7 Type I – Display Refrigerator /Freezer

Intended for 75°F / 55%RH Ambient Application

**ANSI/NSF-7 Type II – Display Refrigerator / Freezer
Intended for 80°F / 55%RH Ambient Application**

**ANSI/NSF-7 – Display Refrigerator
Intended for Bulk Produce**

LOCATION

These merchandisers are designed for displaying products in air conditioned stores where temperature is maintained at or below the ANSI / NSF-7 specified level and relative humidity is maintained at or below 55%. Placing refrigerated merchandisers in direct sunlight, near hot tables or near other heat sources could impair their efficiency. Like other merchandisers, these are sensitive to air disturbances. Air currents passing around merchandisers will seriously impair their operation. Do NOT allow air conditioning, electric fans, open doors or windows, etc. to create air currents around the merchandisers. Product should always be maintained at proper temperature. This means that from the time the product is received, through storage, preparation and display, the temperature of the product must be controlled to maximize the life of the product.

Excel merchandisers have internal frames. A 3 inch (76 mm) space between the rear of the merchandiser and wall must be maintained for air circulation. However, in high ambient conditions, sweating may still occur. If this happens install a method of forced ventilation such as a fan ventilation kit. A 7-inch (178 mm) space is required between the facade top and the ceiling. A Louvered Facade Panel kit is available that will allow for a top spacing minimum clearance of 3 inches (76 mm).



This warning does not mean that Hussmann products will cause cancer or reproductive harm, or is in violation of any product-safety standards or requirements. As clarified by the California State government, Proposition 65 can be considered more of a 'right to know' law than a pure product safety law. When used as designed, Hussmann believes that our products are not harmful. We provide the Proposition 65 warning to stay in compliance with California State law. It is your responsibility to provide accurate Proposition 65 warning labels to your customers when necessary. For more information on Proposition 65, please visit the California State government website.

WARNING

Do not walk on top of case.
Do not store items or flammable materials atop the case.

FREEDOM LINE DESCRIPTION

Freedom Line models like the CF5X and DF5NX merchandisers are designed to be ready for remote installation of a top-mounted, air-cooled condensing unit, such as Hussmann’s TCMXA404A to TCMXD404A series of condensing units. They are controlled by the electronic control. The case temperature is controlled by cycling the compressor based on the discharge air temperature input. The sensor for this input is located in the discharge air stream above the interior top panel. Defrost is time initiated and temperature terminated. The control is pre-programmed for medium temperature food operation and is adjusted for the required temperature by the keypad located on the front of the controller, which is on top of the case. Freedom cases running on individual condensing units may be installed as stand-alone cases with ends, or as part of a lineup. When installed in a lineup, Hussmann recommends that partitions be installed between individual cases to prevent frost buildup and other issues that might result from different defrost schedules and operating temperatures.

SHIPPING DAMAGE

All equipment should be thoroughly examined for shipping damage before and during unloading. This equipment has been carefully inspected at our factory. Any claim for loss or damage must be made to the carrier. The carrier will provide any necessary inspection reports and/or claim forms.

Apparent Loss or Damage

If there is an obvious loss or damage, it must be noted on the freight bill or express receipt and signed by the carrier’s agent; otherwise, carrier may refuse claim.

Concealed Loss or Damage

When loss or damage is not apparent until after equipment is uncrated, retain all packing materials and submit a written request to the carrier for inspection, within 15 days.

UNLOADING

Improper handling may cause damage to the merchandiser when unloading. To avoid damage:

1. Do not drag the merchandiser out of the trailer. Use a Johnson bar (mule).
2. Use one dolly to remove the merchandiser from the trailer.
3. Use two dollies to move merchandisers to lineup.

SERIAL PLATE LOCATION

Direct a flashlight through the return air grille to locate the serial plate. **BE SURE TO POSITION WIDE ISLAND MERCHANDISER FRONTS PROPERLY.** The front of wide island merchandisers is readily identified by the location of the serial plate affixed to the inside of the left front assembly. Since all electrical and refrigeration connections will be made at the front side, the fronts will need to be positioned according to the store plan layout.



EXTERIOR LOADING

Do NOT walk on top of merchandisers or damage to the merchandisers and serious personal injury could occur. THEY ARE NOT STRUCTURALLY DESIGNED TO SUPPORT EXCESSIVE EXTERNAL LOADING such as the weight of a person. Do not place heavy objects on the merchandiser.

MERCHANDISERS SHIPPED WITH END INSTALLED

If the merchandiser was shipped with the end installed, two long bolts were used to hold the shipping brace to the end. If the shipping bolts are reinserted after removing the brace, they will extend into the product area. THEREFORE, BE SURE TO REPLACE THESE BOLTS WITH THE SHORTER BOLTS PROVIDED. NSF requires any bolt or screw in the product area be capped or cut off if it has more than three exposed threads.

NOTE:

Be careful not to damage the factory installed end while moving the case. Make sure that tools are positioned past the end and beneath the merchandiser's support bar.

MOVING MERCHANDISER INTO POSITION

The electrical box and GFCI receptacle are mounted on top of the case. They can be temporarily detached and suspended if required to provide clearance for door openings during shipment and installation. **Do not suspend these components by their wire conduits.** The case height without these components installed on top is 81.75 in. (2102 mm). Be sure to replace all screws and to secure all components. The condensing unit produces vibration that can cause screws to loosen. See photo at upper left corner of this page.

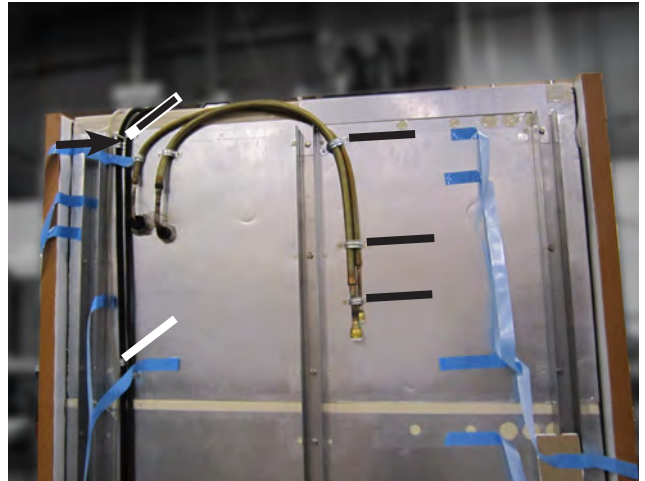

Secure Flex Hoses When Detached

SHIPPING BRACES

Move the merchandiser as close as possible to its permanent location and then remove all packaging. Check for damage before discarding packaging. Remove all separately packed accessories such as kits and shelves. Remove end braces and discard hardware

SHIPPING RIDER

Each merchandiser is shipped on a rider to protect the factory installed front legs, and to make positioning the merchandiser easier. **DO NOT remove the front rider until the merchandiser has been positioned.** Once the rider is removed, the case must be lifted –NOT PUSHED– to reposition. To remove the rider, remove bolts attaching rider to each leg.

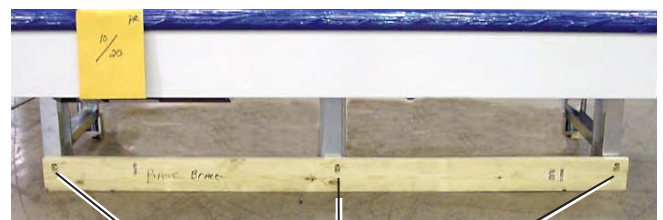

Remove Bolts from Front

MERCHANDISER LEVELING

Merchandisers must be installed level to ensure proper operation of the refrigeration system and to ensure proper drainage of defrost water. During all steps of setting, joining and leveling merchandisers, close attention to position and operation must be maintained.

NOTE: BEGIN LINEUP LEVELING FROM THE HIGHEST POINT OF THE STORE FLOOR.



CAUTION

Tipping Hazard

Case tipping may occur if cases are not properly leveled and secured, or if cases are not properly loaded.

Preparation

1. Using store blueprints, measure off and mark on floor the exact dimensions/locations of the merchandiser footprint. **A 3 inch space is required behind each merchandiser to prevent condensation.**
2. Snap a chalk line for the front and rear positions of the base legs.
3. Mark the location of each joint from front to back lines.

4. FLOORS ARE NOT LEVEL!!! When working with two or more merchandisers to be joined, the whole lineup must be leveled on the same plane, left to right and front to back. This means that the entire lineup must be brought up to the level of the highest case in the lineup.

Along the lines previously marked, find the highest point of the floor by:

- Walking the floor and noticing any dips or mounds;
- Using a string level; and
- Using a transit.

Leveling

Position the first merchandiser at the highest point on the floor. Work outward from that point to create the merchandiser lineup. Use a 48 inch (1220 mm) or longer level for end-to-end leveling. The rear edge of the top foam panel of the merchandiser is a good location for the level at the rear of the case, and the top rail is a good location for the level at the front of the merchandiser. For leveling the merchandiser front-to-rear, a 24 inch (610 mm) level should be placed on the lower flange of the merchandiser end frame. If the merchandiser has a factory installed end, the level should be placed on the canopy support brackets on top of the merchandiser. Suggested level locations are shown in the illustrations on the following page.

Level the merchandiser by all four corners. Start at the rear by placing the provided shims as needed under each end of the rear base rail. The shims are long enough to allow adjoining merchandisers to be leveled with the same shim. **When the rear of the case is level end-to-end, move to the front of the case.** Use shims as needed at each front corner so that the front is also level from end-to-end and front-to-rear.

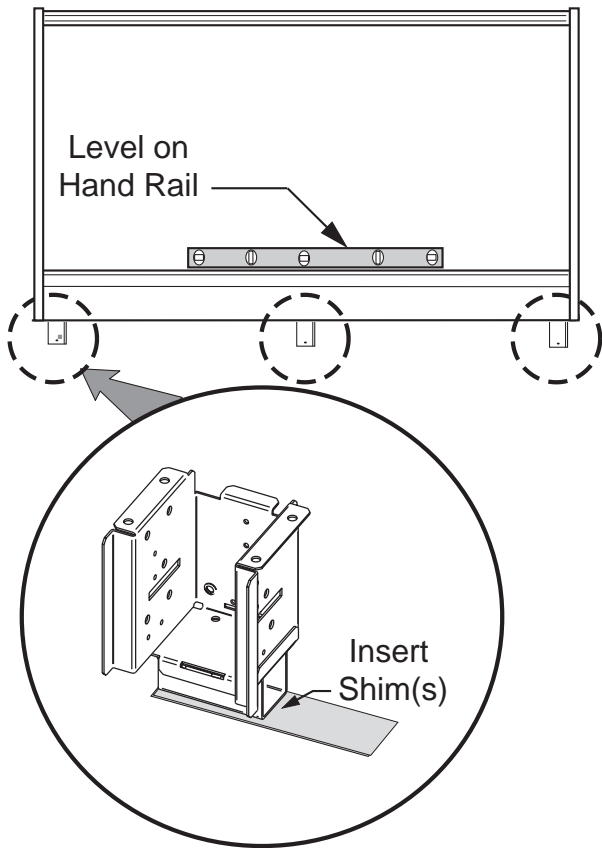

The merchandiser should be solidly supported at least every 4 feet (1220 mm). Once the merchandiser is level, if any gaps are present under the base rail, shims should be inserted approximately in line with the center front support legs to support the rear of the case. At the front of the case, insert shims under each of the center legs so that they support the front of the merchandiser.

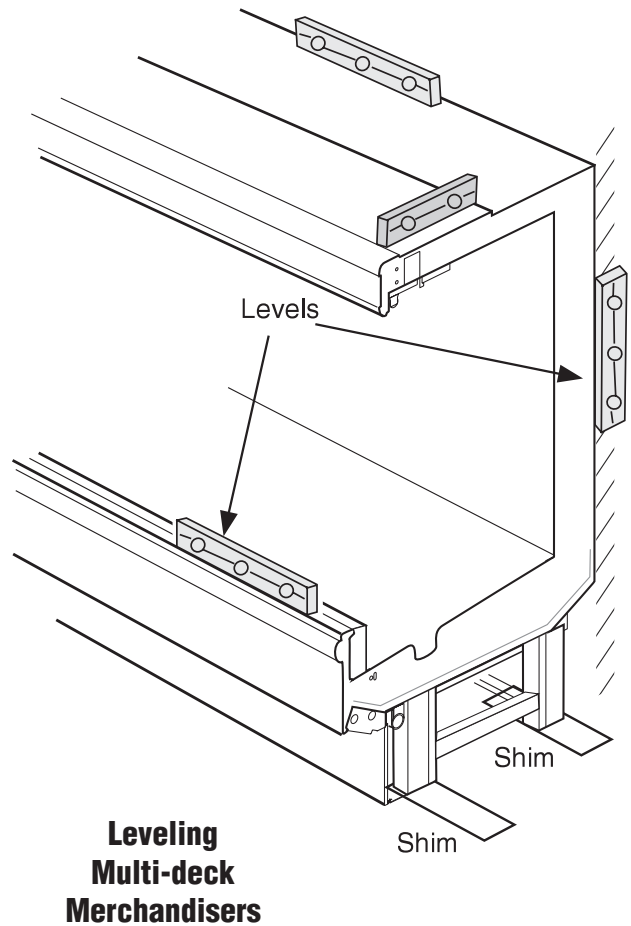
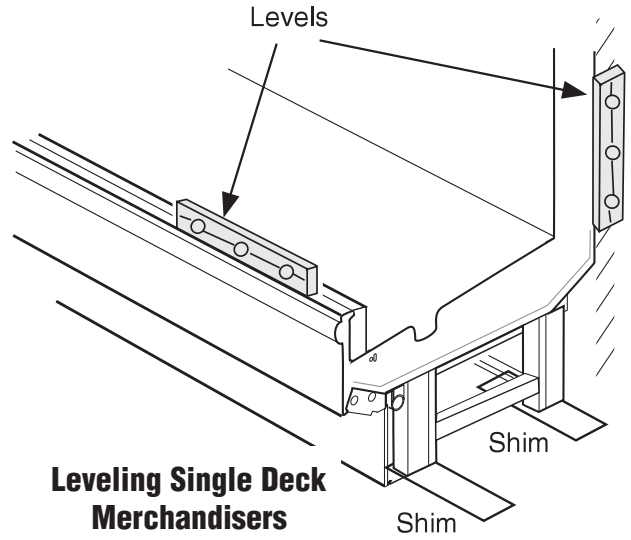

NOTE: Do not place levels on Display Pans or on Shelves.

Merchandisers with optional front rail light must have end caps installed. See Page 1-20 for details.

JOINING INSTRUCTIONS

Sectional construction means that two or more merchandisers may be joined in line yielding one long continuous display requiring one pair of ends.

ALL JOINTS MUST BE AIR-TIGHT TO PREVENT FORMATION OF ICE OR CONDENSATION.

Prep Merchandiser

1. Check to be sure that merchandisers are level and that the factory-installed nut retainers are in place. Locate the Joining Kit and check contents.
2. Remove shelves (if installed), display racks, pans and front air grilles from the right end.
3. Remove the rear interior panel(s) from the right end. On multi-deck merchandisers remove the lower back panel first. To remove a panel, lift it up from its bottom edge and out. No tools required.

Excessive ambient conditions may cause condensation and therefore sweating of doors. Facility operators should monitor doors and floor conditions to ensure safety of persons.

Apply Gaskets as Follows:

Right End

1. Apply the 1 inch (25 mm) gasket around the perimeter of the merchandiser as shown. It must be at the edge. Check to be sure that there are no gaps between gasket and merchandiser.
2. Apply the 1⁵/₈ in. (41 mm) gasket so that one edge is on the metal merchandiser frame and the parallel edge laps the 1 inch gasket. Check to be sure that there are no gaps between merchandiser and gaskets.

REFER TO GASKET DIAGRAM AND DETAIL VIEWS ON NEXT PAGE.

A continuous bead of silicone sealant/ caulk may be used in addition to gaskets on mating surfaces but must not be used in lieu of gaskets.

IMPORTANT

- Do not stretch gasket, especially around corners.
- Do not butt gaskets; always overlap them as shown.
- Remove paper backing after gasket has been applied.
- *Perimeter gasket required by NSF.*
- End caps required for rail light.

Maintain a 3 in. space between merchandiser and wall to prevent condensation.

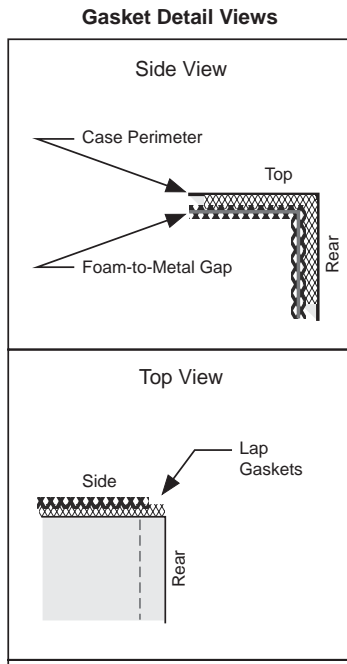
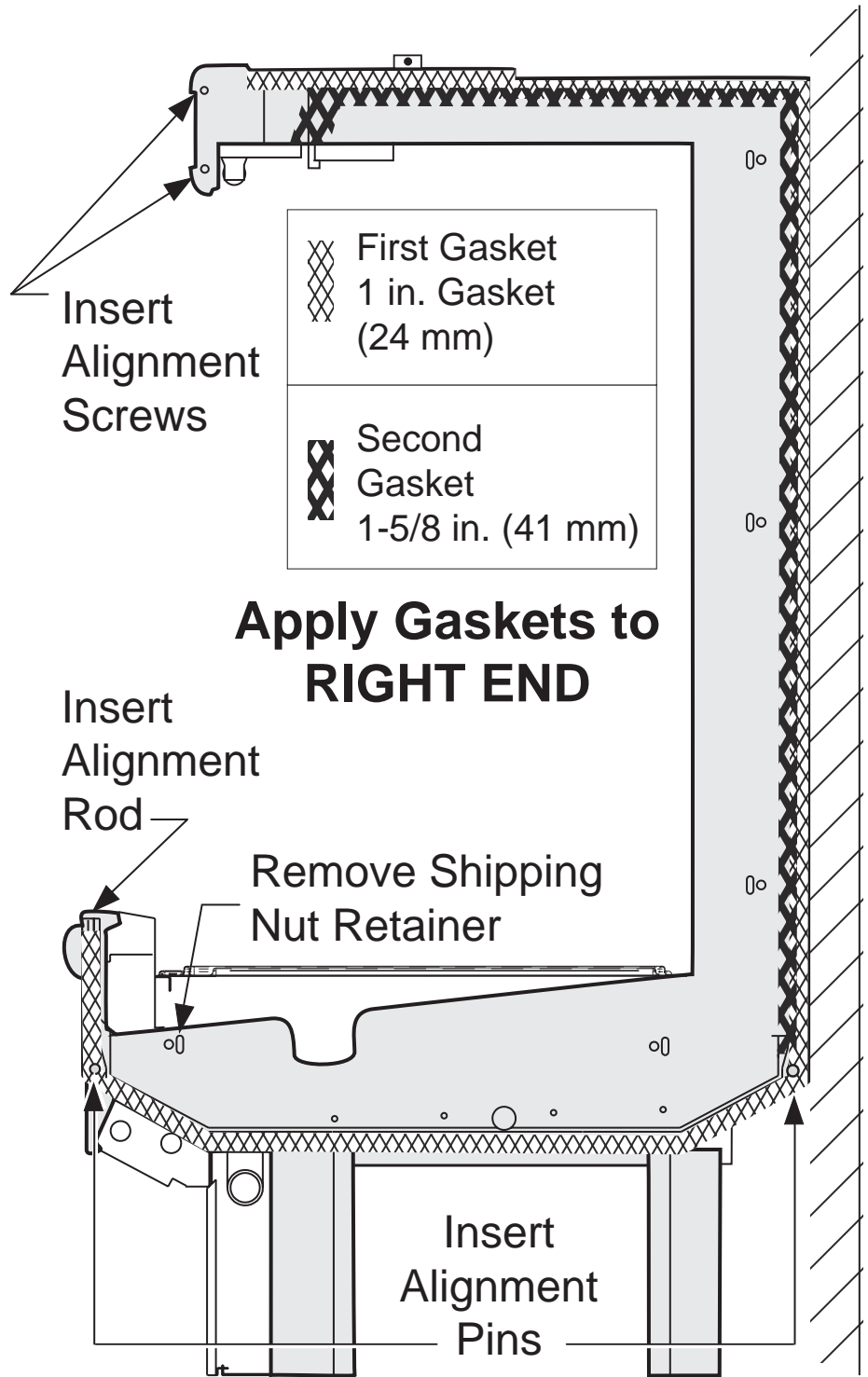

Gasket Location for Joining (Multi-deck)

1-8 INSTALLATION

Align End Frames

IMPORTANT: ALIGNMENT ORDER IS DIFFERENT FROM TIGHTENING ORDER! REFER TO THE ILLUSTRATION.

NOTE: Merchandisers must be level before joining.

1. Insert alignment rod at lower front and lower back.
2. Remove factory-installed nut retainer from lower front end frame(s).

3. Move the second case as close to the first as possible by pushing or using lever bar (mule).

4. Insert the alignment rod ($\frac{1}{4}$ in. diameter x 6 in.) through hole in top rail, align and insert second rod. See standard front detail below. For glass fronts, refer to glass front detail below.

5. Match alignment pins with corresponding holes in foam bottom and canopy.

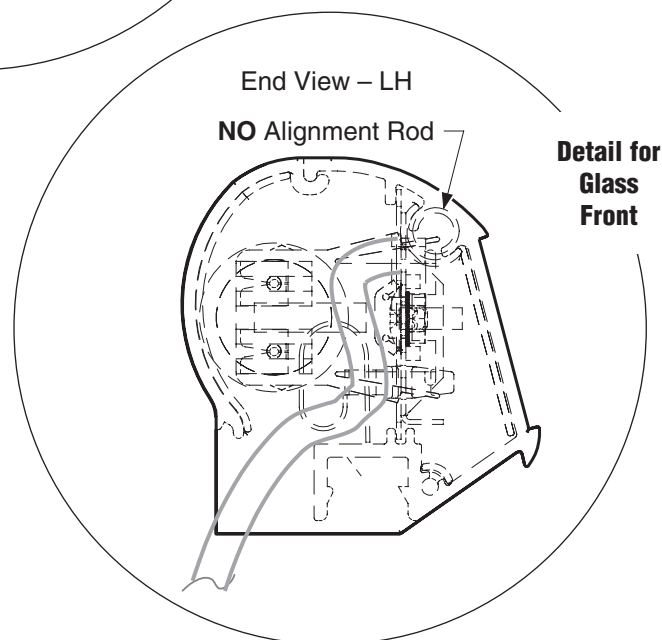
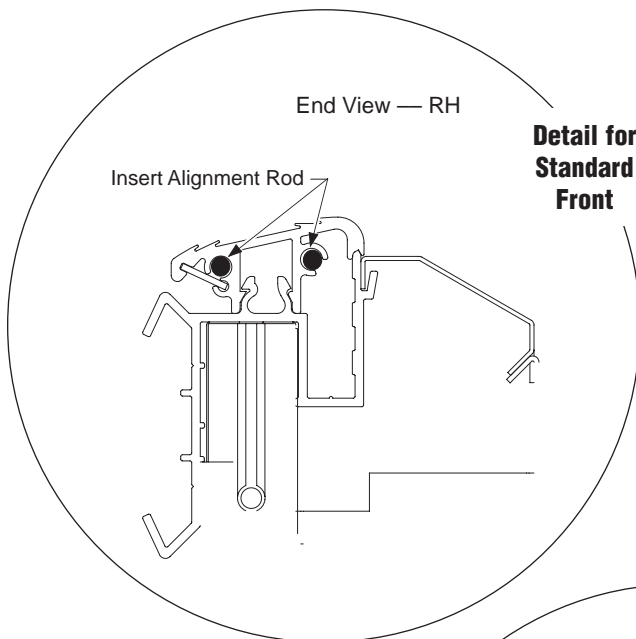

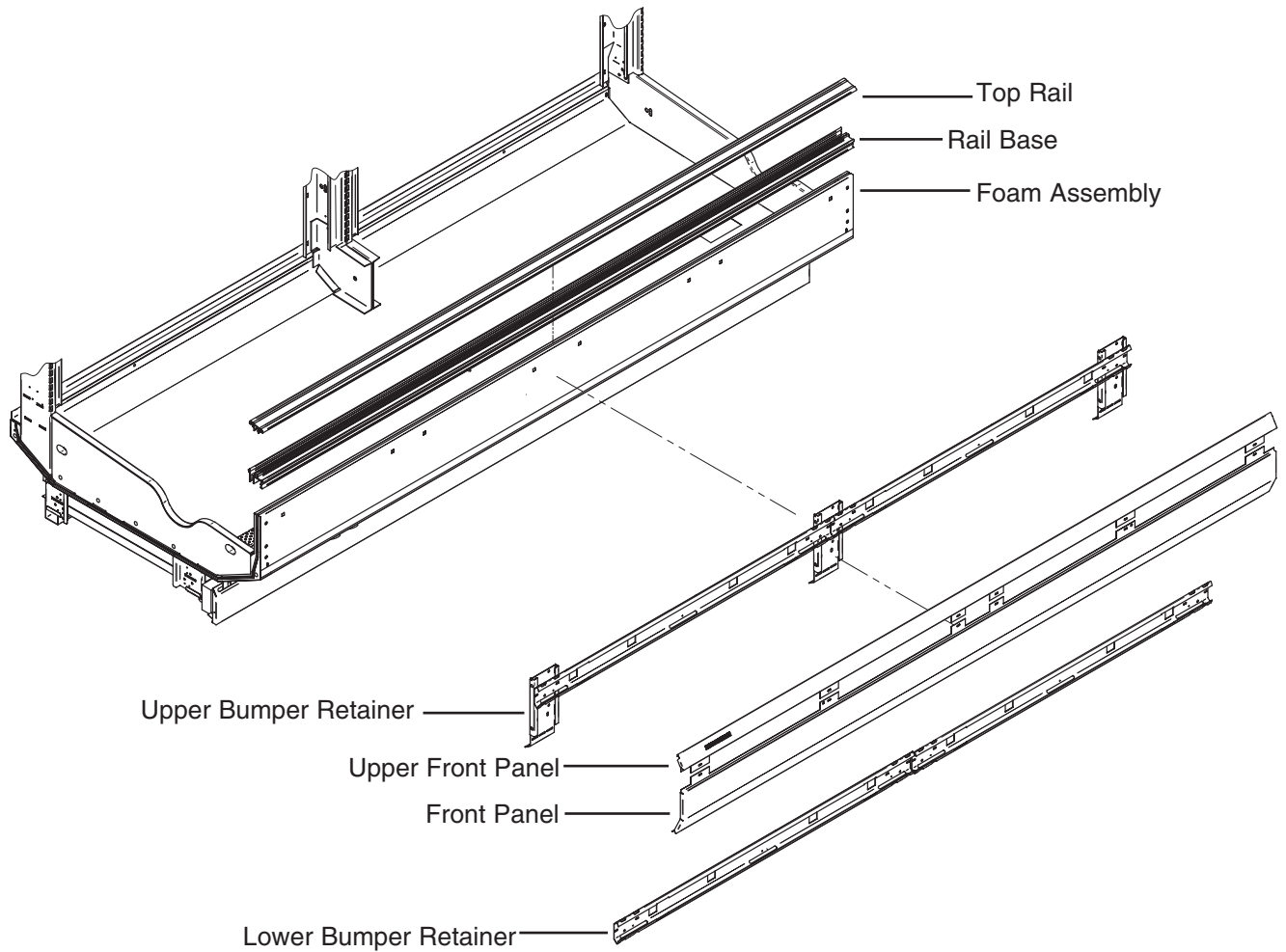

6. **Verify that each merchandiser's upper front panel, front panel, and top rail align before joining merchandisers.** Panels and top rail must have equal overhang at each end of the merchandiser.

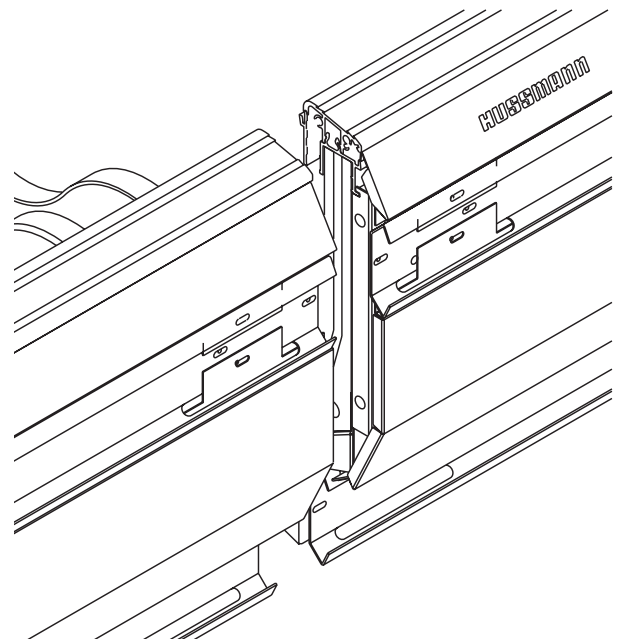



To correct vertical alignment of top rails and upper front panel, adjust shims as necessary.

To correct horizontal alignment of upper front panel and lower front panel, remove the upper bumper to access screws attached to the front panels. Once these screws are loosened, the merchandiser's upper front panel and lower front panel can be adjusted horizontally.

IMPORTANT:

ALIGNMENT ORDER IS DIFFERENT FROM TIGHTENING ORDER!

REFER TO ALIGNMENT DIAGRAM AND DETAIL VIEWS ON THE NEXT PAGE.

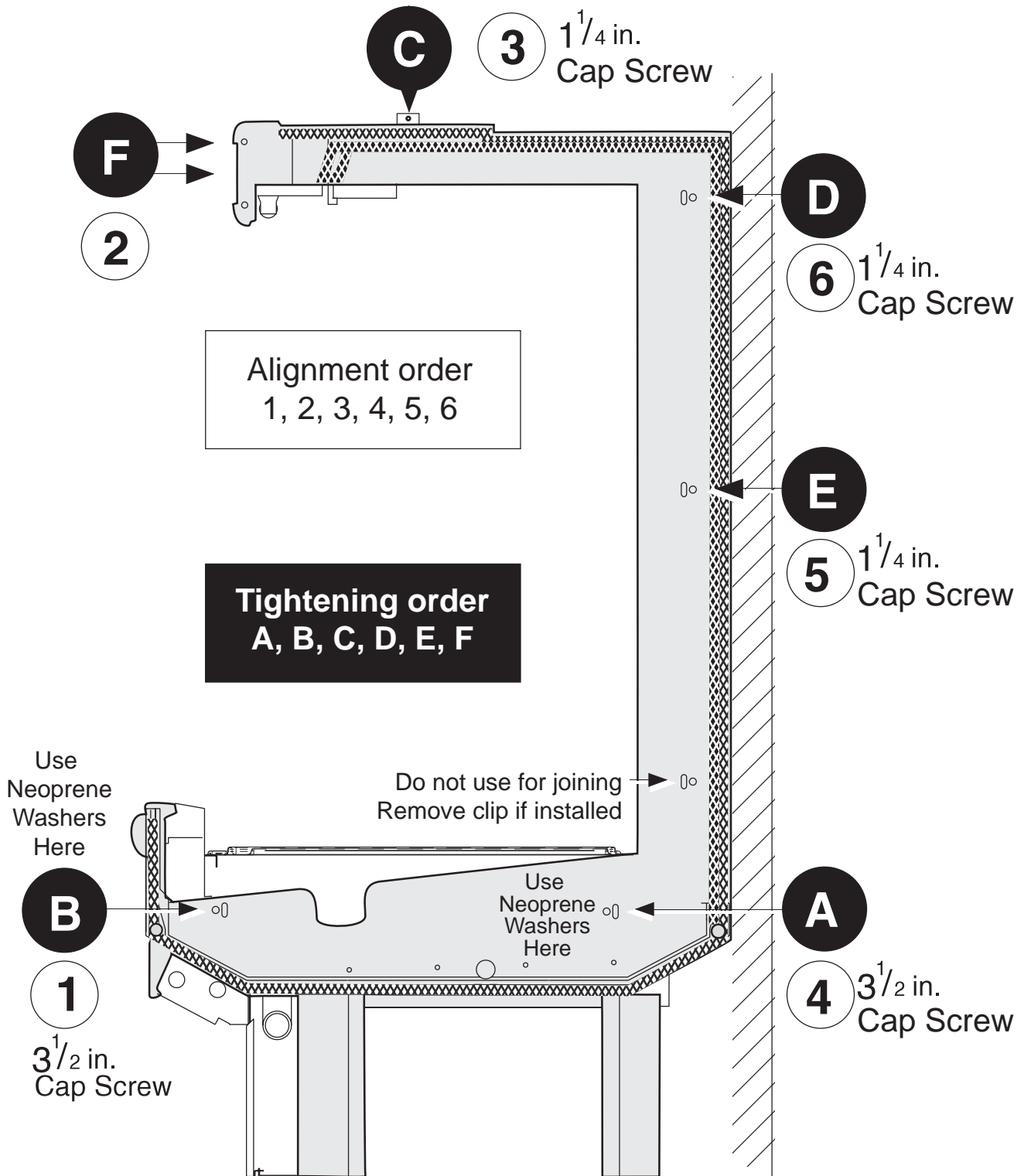

Tighten in Order Shown

Fasten End Frames

1. In both holes in bottom shoe, place a 2-inch neoprene washer between end frame and metal washer of each merchandiser. Loosely assemble bolt, washers, lockwasher and nut as shown.

DO NOT TIGHTEN FULLY.

Do not attempt to draw merchandisers together using nut and bolt.

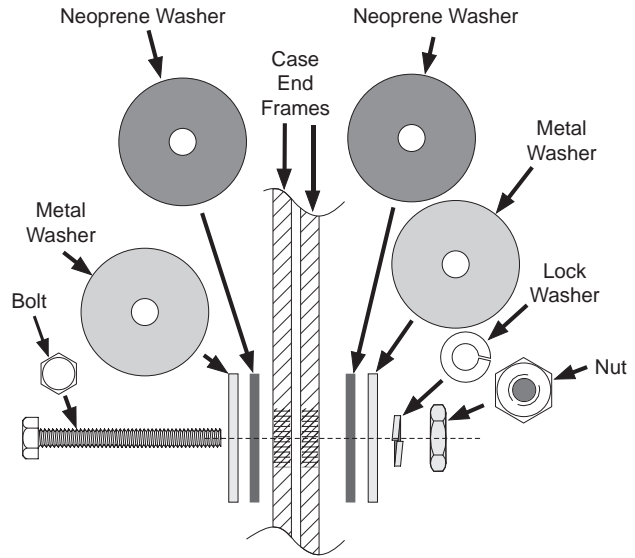
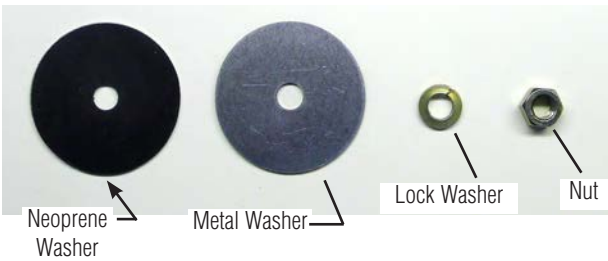

Detail for Connecting Merchandiser End Frames

Fasten Canopies

1. Insert a machine screw (#10 x 1 1/4 in.) through each hole in canopy end cap, align and insert into joining canopy end cap. Fasten with nuts. See detail at top right. **Do not tighten fully.**

2. Draw canopies of multi-deck wall merchandisers together by using a bolt, flat washers, lockwasher and nut in the joining brackets atop the canopy. See detail at top right. **Tighten only until canopies touch.**

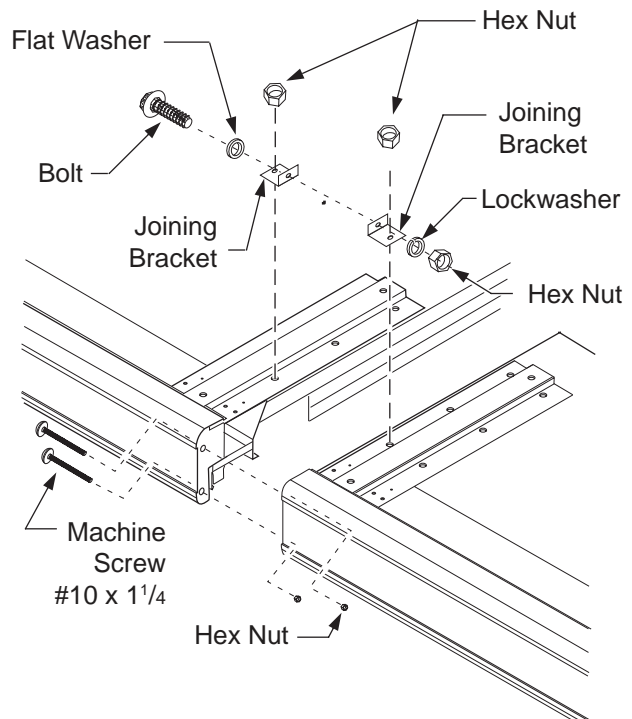

Detail for Connecting Canopies of Multi-deck Wall Merchandisers

Tighten End Frames

1. Begin at lower back to draw end frames tight.
2. Tighten joints following the diagrams until gaskets are compressed, and merchandisers join smoothly.
3. Tighten screws in canopy (F) to complete smooth fit.
4. Place plastic end caps over exposed threads.

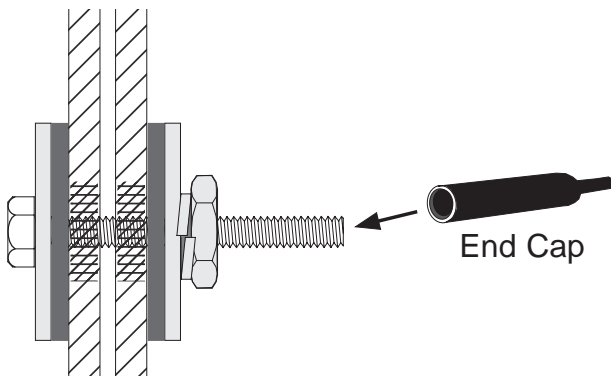

NOTE: End caps must be placed over exposed threads in food product areas to maintain NSF compliance.

Seal Merchandisers

1. Remove wire shelf, interior front panel, and interior panel support bracket to apply butyl tape.

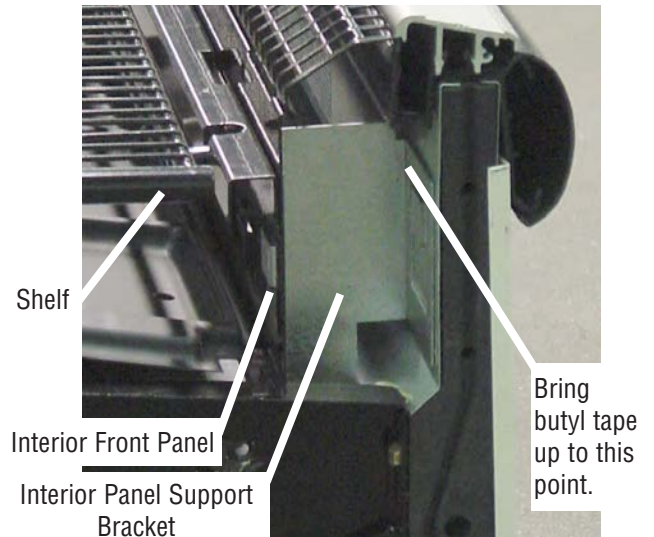

2. Apply butyl tape across the bottom joint. Be sure to extend the tape up the back and front of the merchandiser.

Silicone sealer may be applied around joining bolts on both sides in bottom shoe but isn't necessary if neoprene washers are used.

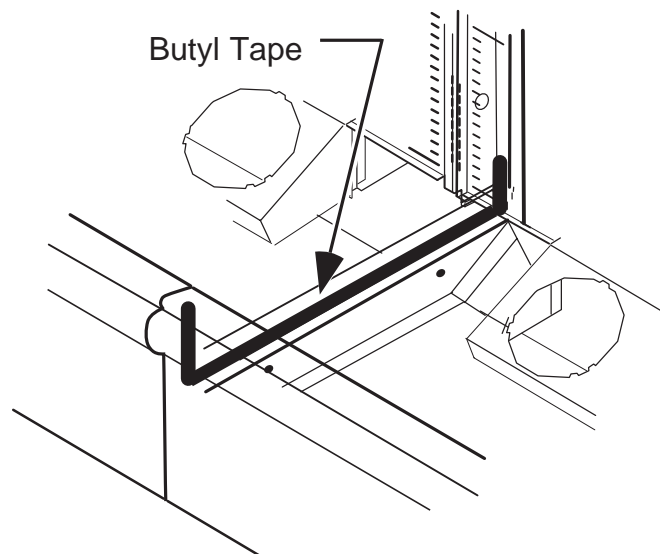

INSTALL SPLASHGUARD BRACKETS

Position splashguard brackets against the merchandiser and level to the floor. Each bracket has a 1 1/2 in. (38 mm) slot at the rear of the bracket where it attaches to the merchandiser. Tighten screws to secure the brackets.

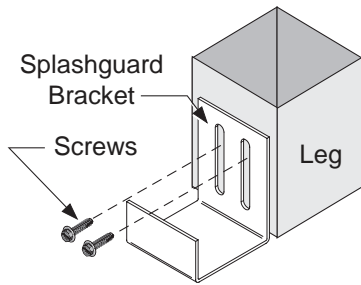

 <p>CAUTION</p>
<p>To avoid leaks, install splashguard brackets before installing drip piping.</p>

OFFSETTING BUMPER

Offsetting the bumper helps to disguise the joint locations, giving the lineup a smoother look.

1. Locate starter bumper shipped with the left-end kit.
2. Remove factory installed bumper by pulling bumper away from bumper retainer. Be careful not to lose the internal joint trim on the bumper.

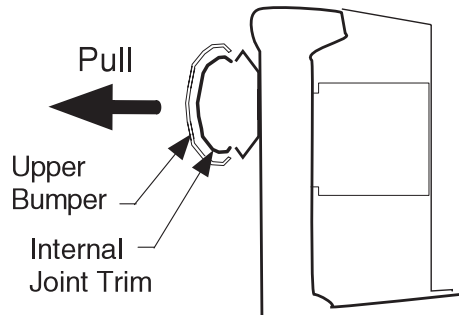

3. If not installed, install bumper end caps as shown below.

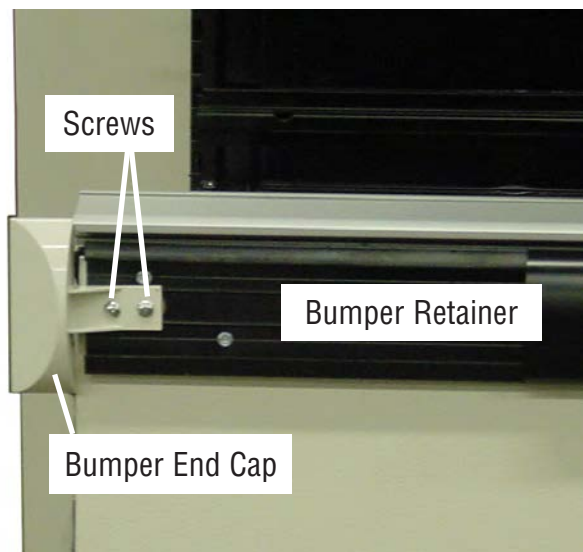

4. Starting at the left end of the lineup, install the bumper starter section first. To install:

- a. Position internal joint trims so that the first is flush to the left-end panel and the second is centered between the started bumper and the full-length bumper as shown on the next page.

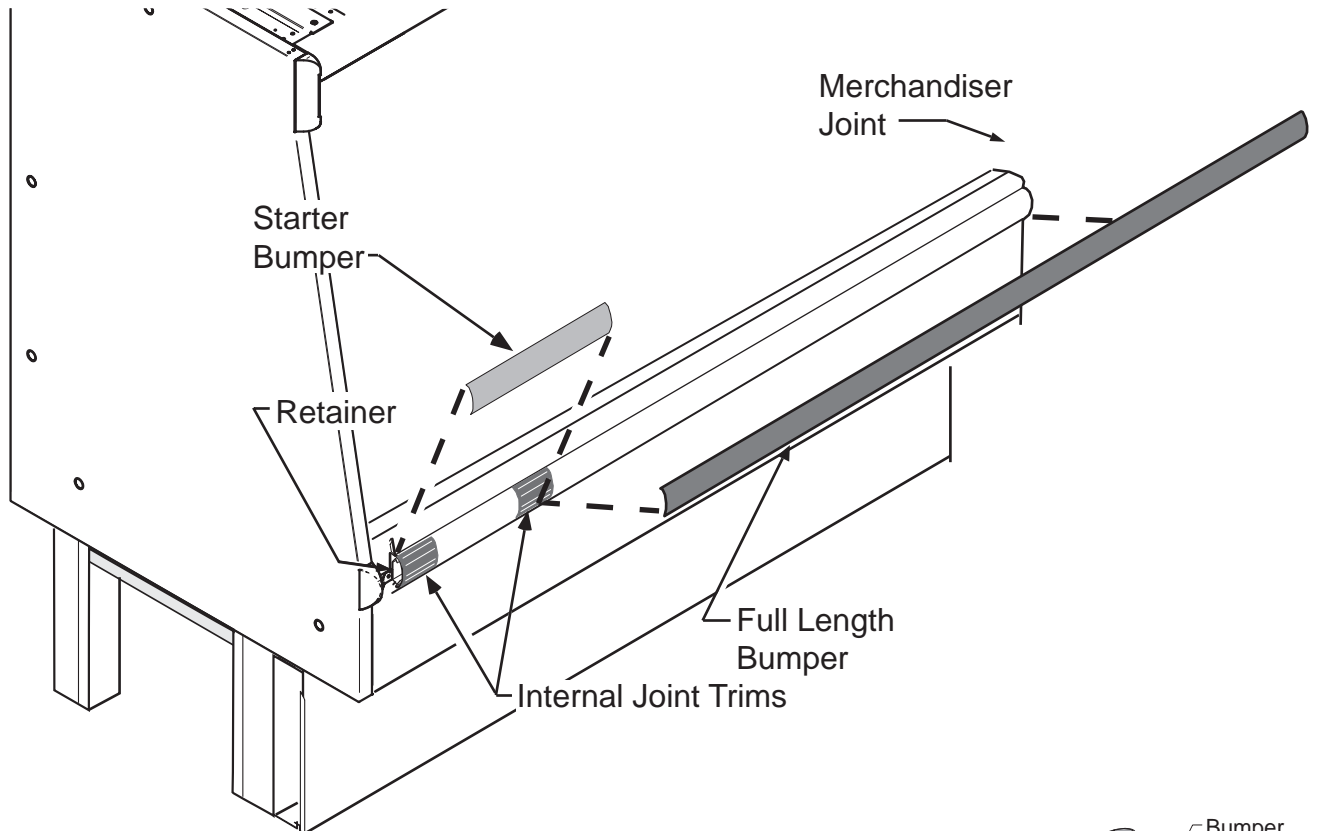

b. Install full-length bumpers and internal trims offset across joints. Make sure that no gaps exist between sections. Continue installing the bumpers the length of the lineup.

5. Once all except the last section of bumper have been installed, refrigerate the merchandiser lineup for at least six (6) hours. The last section of bumper should be kept inside a cooler or refrigerated merchandiser during this time. This will allow the bumper to contract.

6. Go to the right end of the lineup, and tap the bumper to close any gaps.

7. Measure and cut last sections of bumper. Use a miter box and fine-tooth saw to cut last bumper to length. Install the last section.

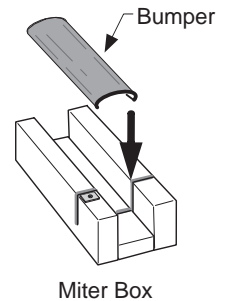

8. Remove protective film from bumper once installation is complete.



INSTALLING PARTITIONS

To join same temperature fixtures on different defrost cycles, an acrylic partition kit is required.

To join like or unlike fixtures operating at different temperatures, a 1 1/2 in. (38 mm) partition kit is required. It must be installed when setting the lineup.

Instructions for installing these partitions are included with the kits.

INSTALLING END ASSEMBLIES

The following information is provided for field or retrofit installation:

1. Prepare Merchandiser

a. Remove shelves (if installed), display racks, pans, front shelf supports and front air grilles from the section of merchandiser where end is to be installed.

b. Remove the interior rear panel(s). On multi-deck merchandisers, remove the lower back panel, lift it up from its bottom edge and out. No tools required.

c. Right End Only

Install Nut Retainers into right end frame at locations shown.

d. Left End Only

Check that factory-installed Nut Retainers are in place.

e. Remove bumper by pulling bumper away from bumper retainers. Be careful not to lose the internal joint trims.

f. Optional Front Rail Light Only

Check that end cap is in place before gaskets are applied.

2. Apply Gaskets to End Frame as Follows:

a. Apply the 1 5/8 in. (41 mm) gasket to canopy and rear of the merchandiser as shown on the next page. It must be at the edge. Check to be sure that there are no gaps between merchandiser and gasket.

b. Apply the 1 inch (25 mm) gasket from front to back. It should lap the 1 5/8 in. gasket at the rear. Check to be sure that there are no gaps between merchandiser and gaskets. **Refer to detail below.**

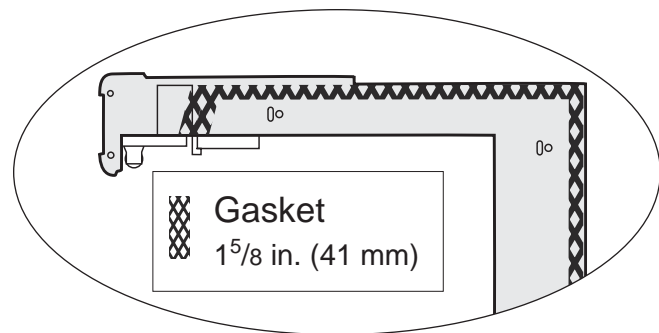

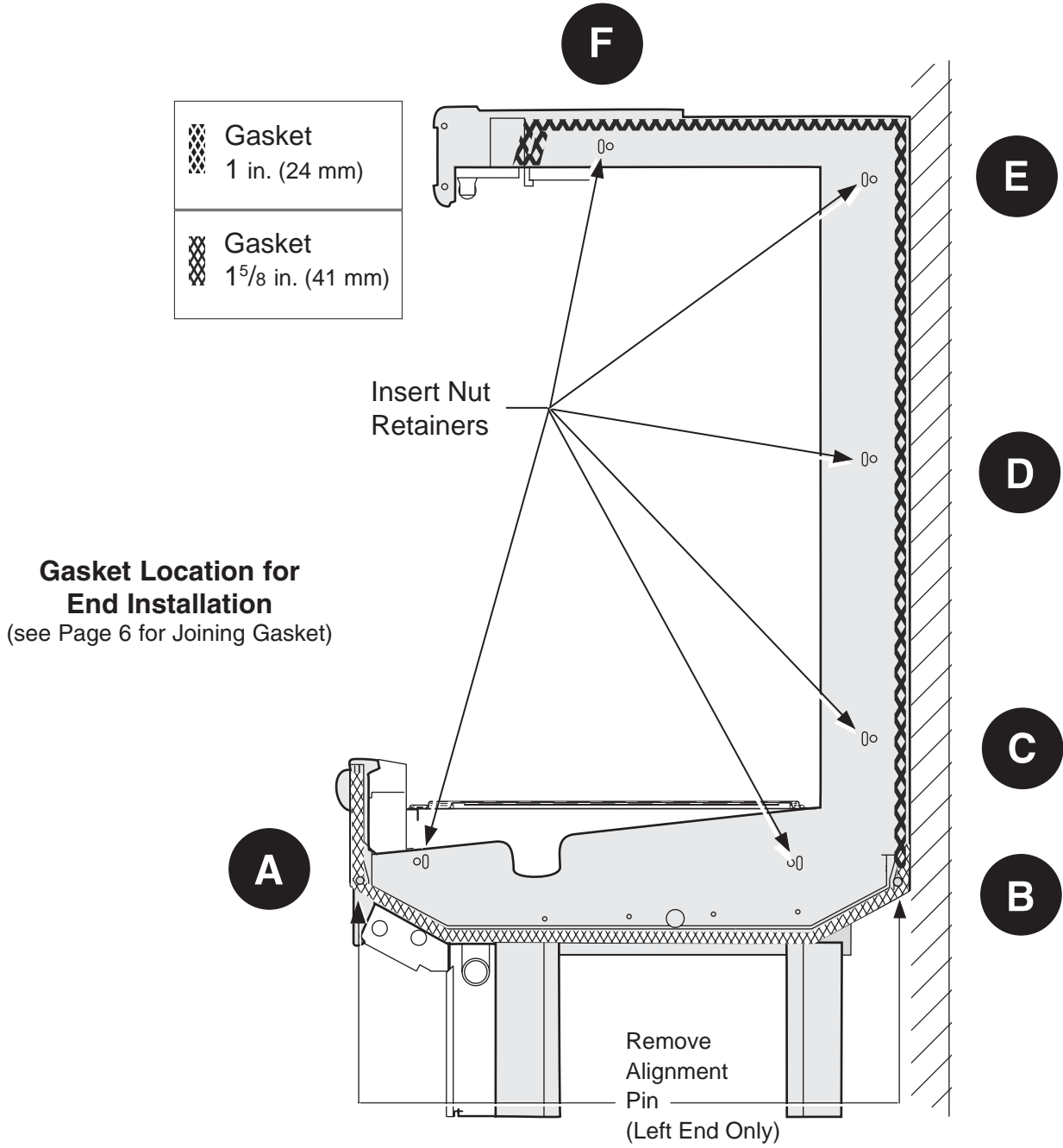

IMPORTANT

- Do not stretch gasket, especially around corners.
- Do not butt gaskets; always overlap them as shown.
- Remove paper backing after gasket has been applied.
- *Perimeter gasket required by NSF.*
- End caps required for rail light.

3. Fasten End Assembly to Merchandiser

a. Use Bolt and washer to fasten end assembly to merchandiser

b. Use washer with Hex Nut to secure bolt and washer at front (A) and canopy (F), similar to joining process.

c. Tighten in order shown on Page 1-11. After fasteners have been tightened, insert Plug Buttons.

Flat Washer
5/16-WI Zinc

Cap Screw
5/16-18 x 1 3/4

End Assembly

Cap Screw
5/16-18 x 2 1/2

Plug Button

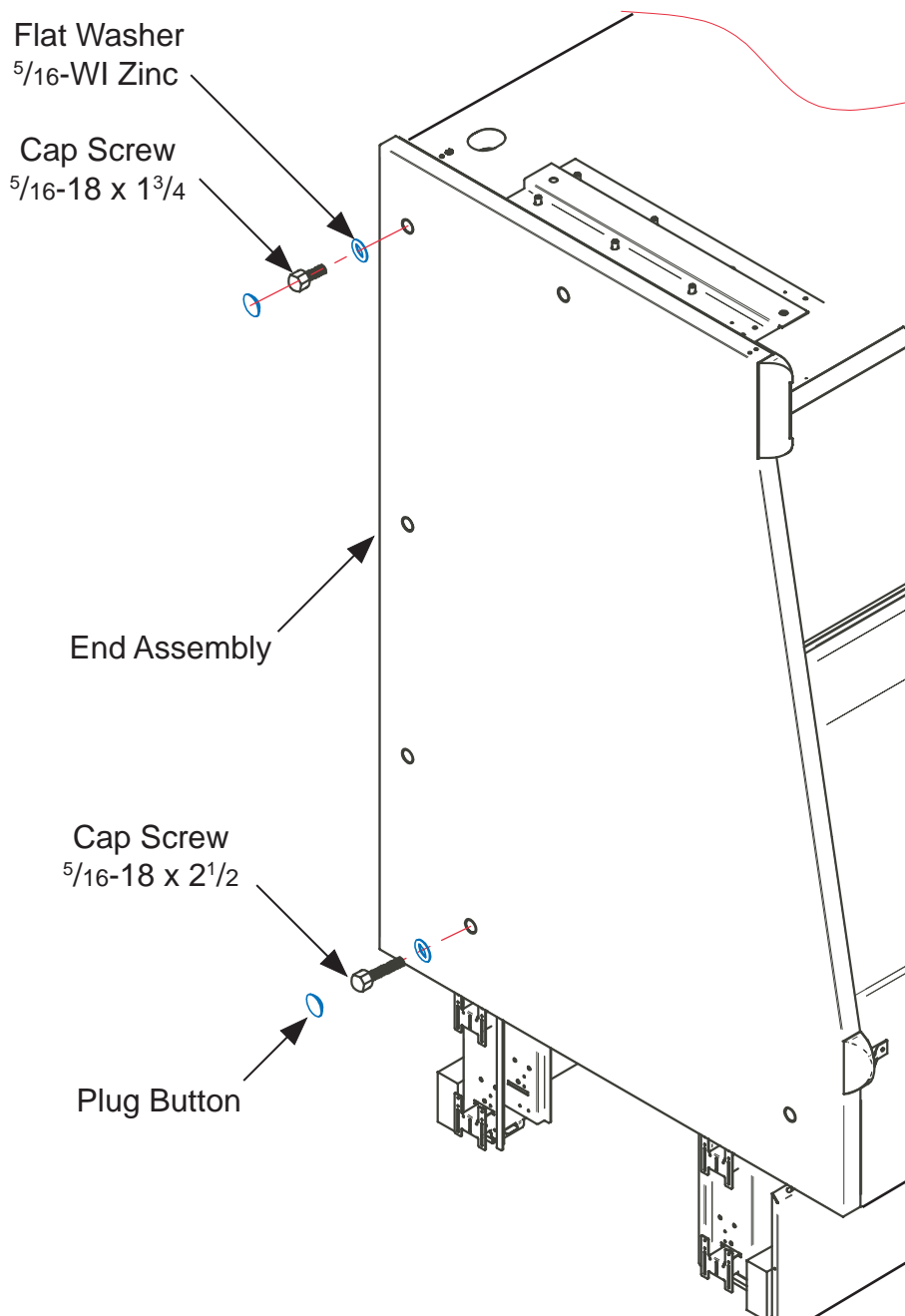
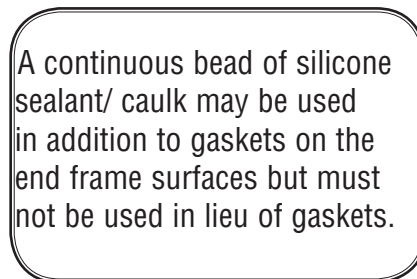
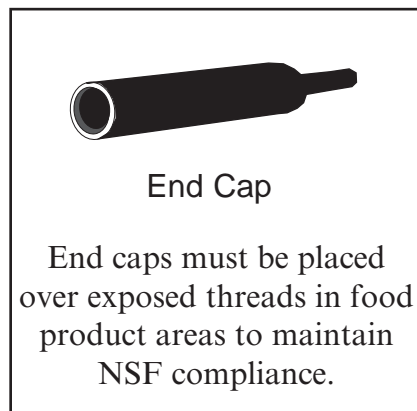

d. Install Top and Bottom Corner Castings as shown below.

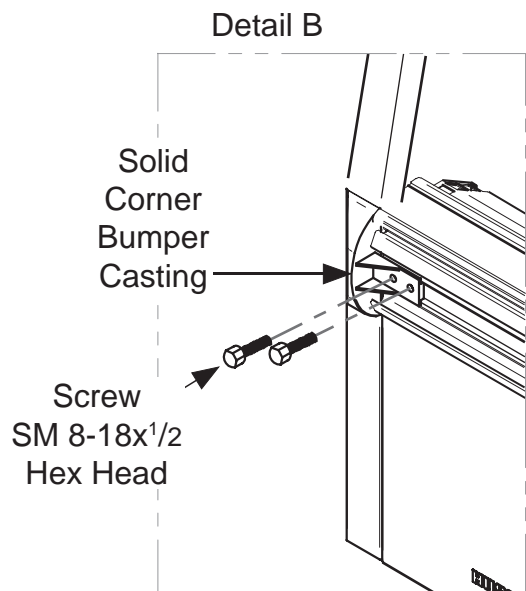
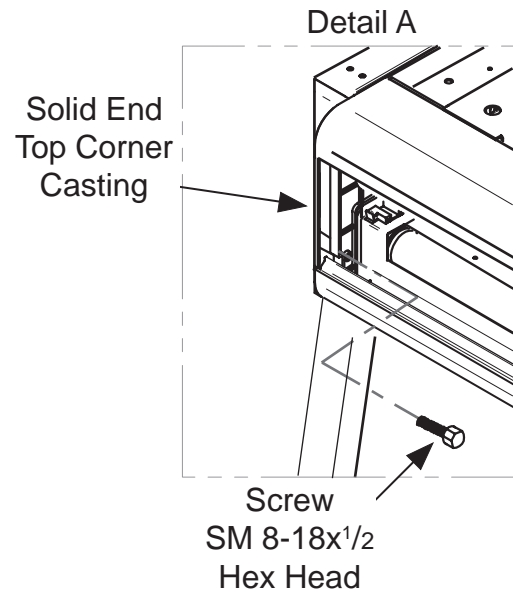
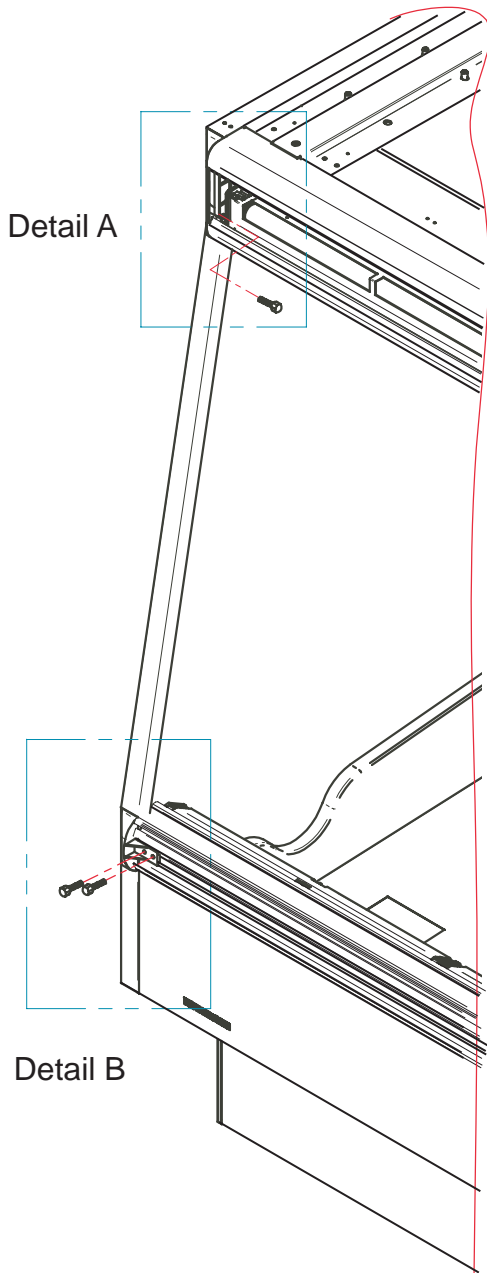

4. Install End Splashguard

a. Insert back of bracket through slot in leg. Use Screws to attach End Splashguard Retainers to end frame.

Note: Not all models have two brackets per leg.

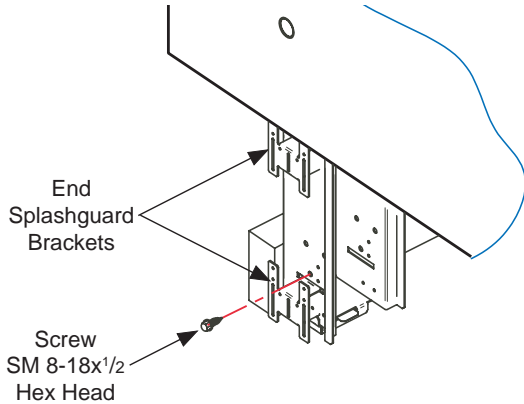

b. Align forward edge of End Splashguard with front splashguard, with lower edge resting on floor. Fasten End Splashguard to bracket with Screws.

c. Slip End Splashguard Cover under end splashguard assembly. Fasten to end splashguard and upper brackets with Screws.

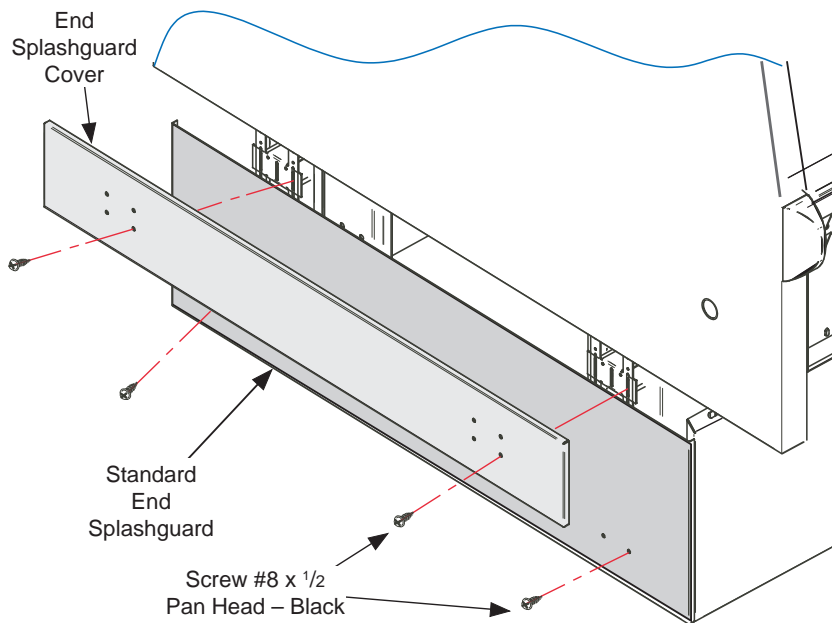

5. Seal End to End Frame

Remove front shelf and shelf support bracket. Apply a 1/2 in. bead of silicone at the back of the merchandiser, starting at the first slot. Continue across the bottom and up the front as shown below. Use field-supplied silicone in any gap between front support bracket and end assembly.

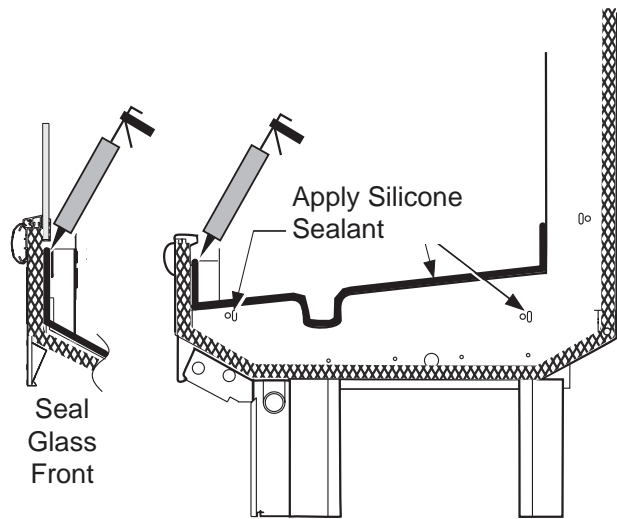

Re-install bumpers as described beginning on Page 1-14.

Note: Optional end bumpers are factory-installed only.

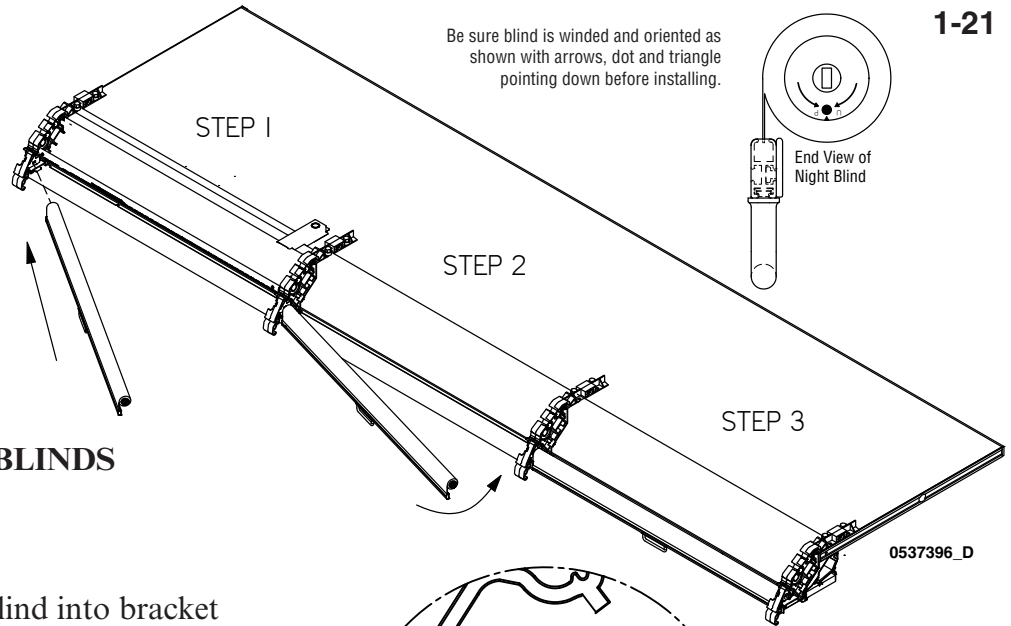

INSTALLING NIGHT BLINDS

STEP 1

Slide the lefthand night blind into bracket cutout.

NOTE Left section of case always uses the front cutout. Alternate front to back for remaining sections.

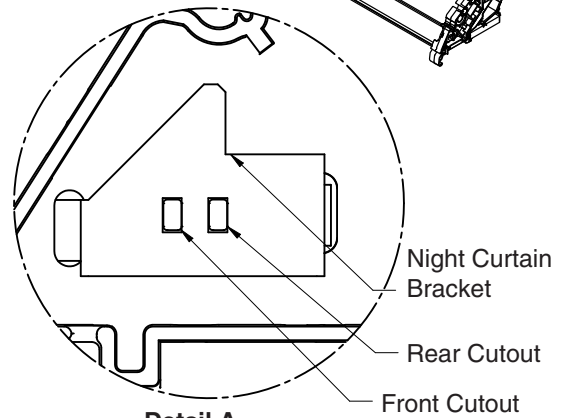

Detail A

Brackets Always on Left Side of Night Curtain

STEP 2

Swing righthand side of night blind into slot on side of canopy support arm.

NOTE Left section of case always uses the bottom slot. Alternate bottom to top for remaining sections.

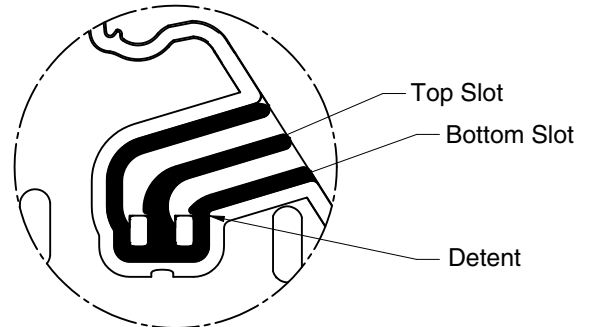

Detail B

Slots always on right side of night blind

STEP 3

Push/pull down on night blind slightly to slide pin past detent.

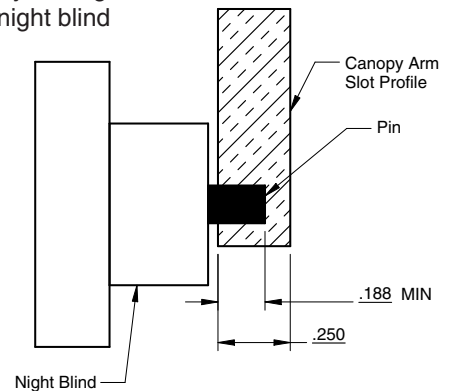

STEP 4

Check pin engagement to ensure at least 3/16" of pin is firmly in the slot.

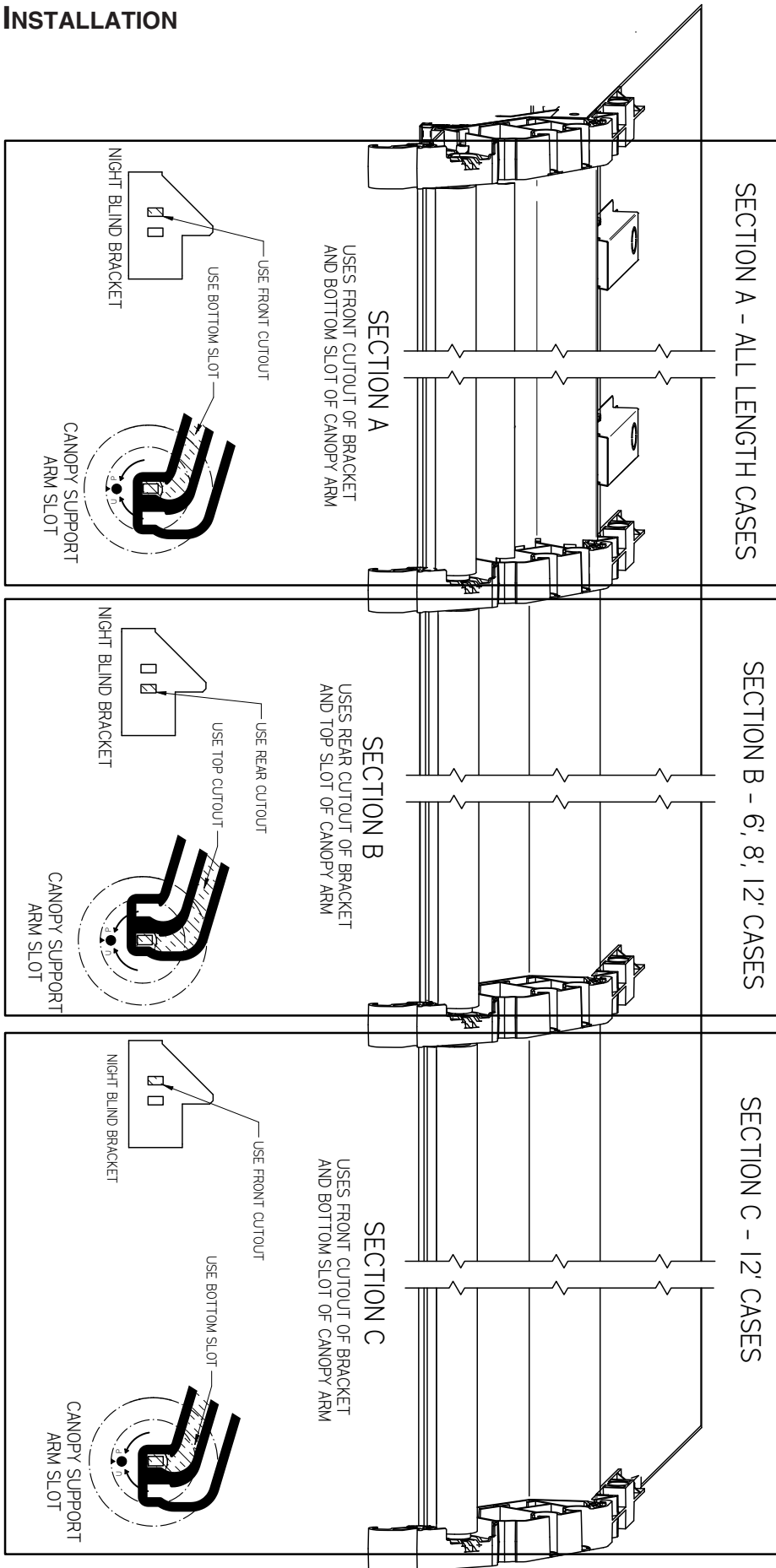

LOADING BLIND SPRING

Night blinds are delivered pre-loaded. However, if it is necessary to load night blind spring, use a wrench (part number 0477098) to twist rectangular pin on right side of night blind. Twist clockwise 14 to 15 full revolutions.

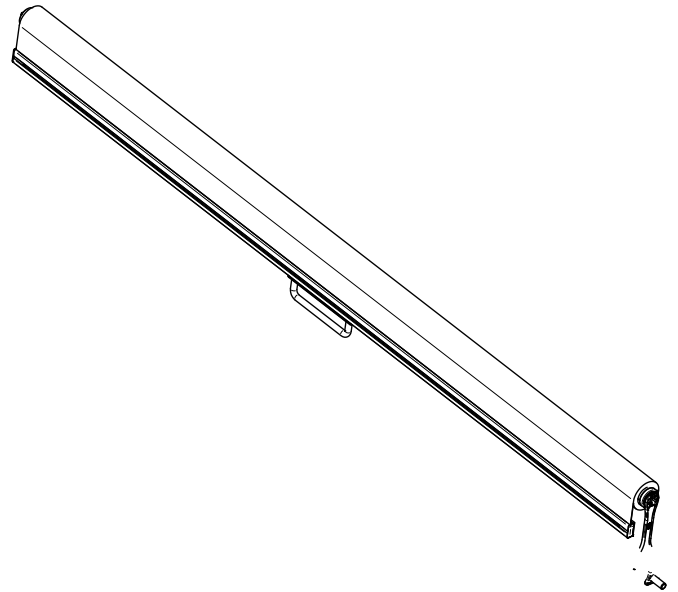

NOTE  **Keep arrow / dot / up pointed up while winding. Keep pointed down when installed.**



Image showing wrench tightening night blind

Reference Mark (triangle or circle) must be oriented upward when winding and downward during installation.

Night Blind Handle

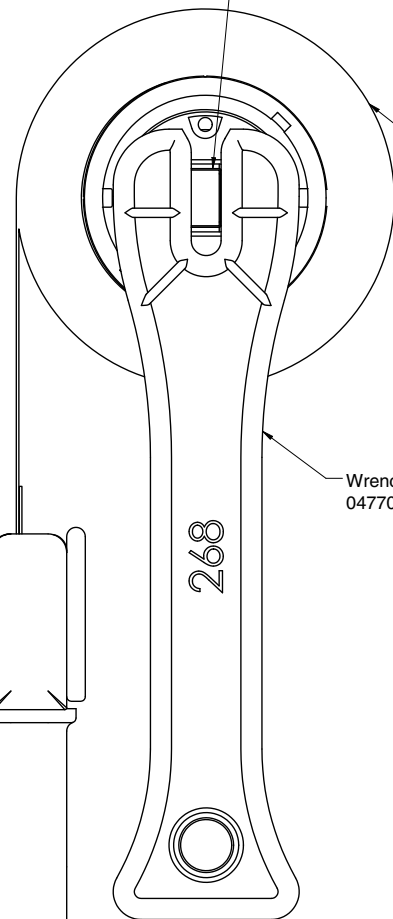

Rectangular Pin

Night Blind

Wrench 0477098

Twist wrench clockwise for 14 to 15 revolutions



TROUBLESHOOTING NIGHT BLINDS

If night blind is not installed:

STEP 1

Only install brackets on the lefthand support arm and each center support arm.

STEP 2

On the righthand side of each arm, insert front tab of bracket into the front slot, then snap into the rear slot.

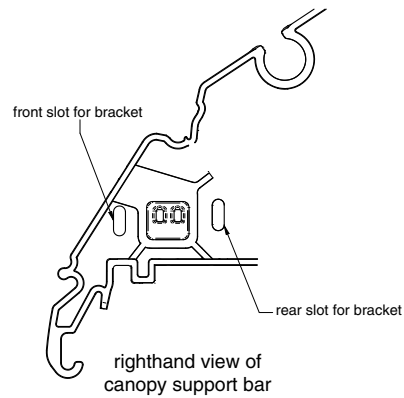
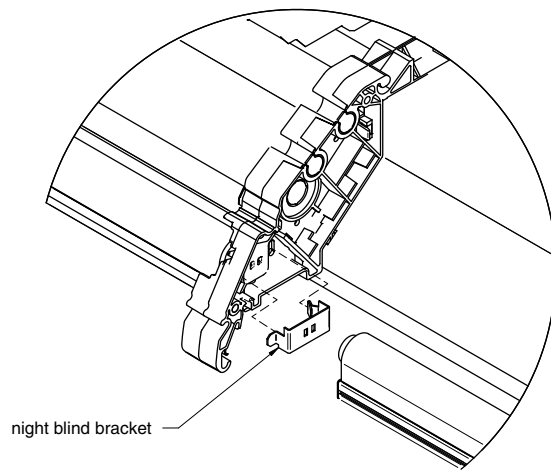

If pin is too short or rounding out canopy arm:

STEP 1

Remove night curtain from case

STEP 2

Use pliers to pull metal pin out to desired length

STEP 3

Replace night curtain into canopy

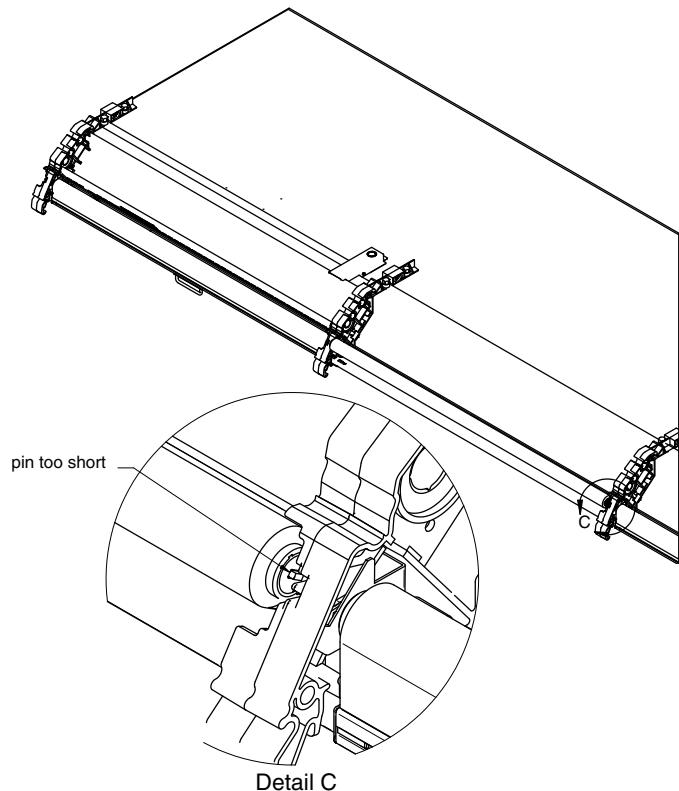

REFRIGERATION / ELECTRICAL / CONTROLLER

FIELD INSTALLATION OF CONDENSING UNIT

In some circumstances store doors may not be tall enough to pass the electrical components through the door. In this situation, the electrical components may be removed temporarily to pass under lower frame store doors.

Condenser mounting brackets are provided on top of the case with pilot holes with specific attachment points for the condensing unit base. The mounting brackets are located on the top right side of the case.

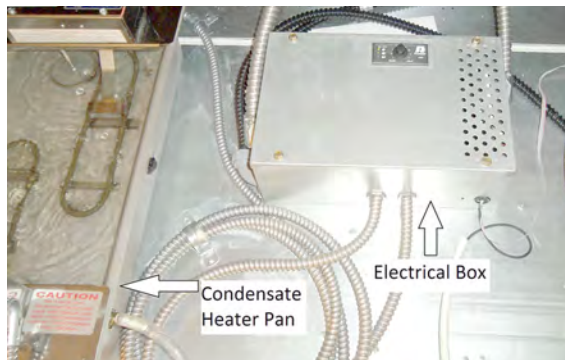

After mounting the condensing unit, the electrical box must be re-attached to the top. The condensate pan, if provided, is packed inside the case and must also be installed on top of the case and wired into the terminal strip provided. Exact component location is not critical; however, the components should be mounted in the general locations shown to ensure that electrical connections reach, and the condensate pan has adequate air flow from the condenser.

WARNING

Opening condensing unit electrical box exposes personnel to electrical hazard and should only be performed by a qualified service technician!

NOTE:

EACH UNIT LENGTH (12FT, 8FT, 6FT, 4FT) HAS DIFFERENT LOCATIONS FOR CONDENSING UNIT AND ELECTRICAL COMPONENTS.

SEE DRAWINGS OF THE COMPONENT LOCATION NEXT TWO PAGES.

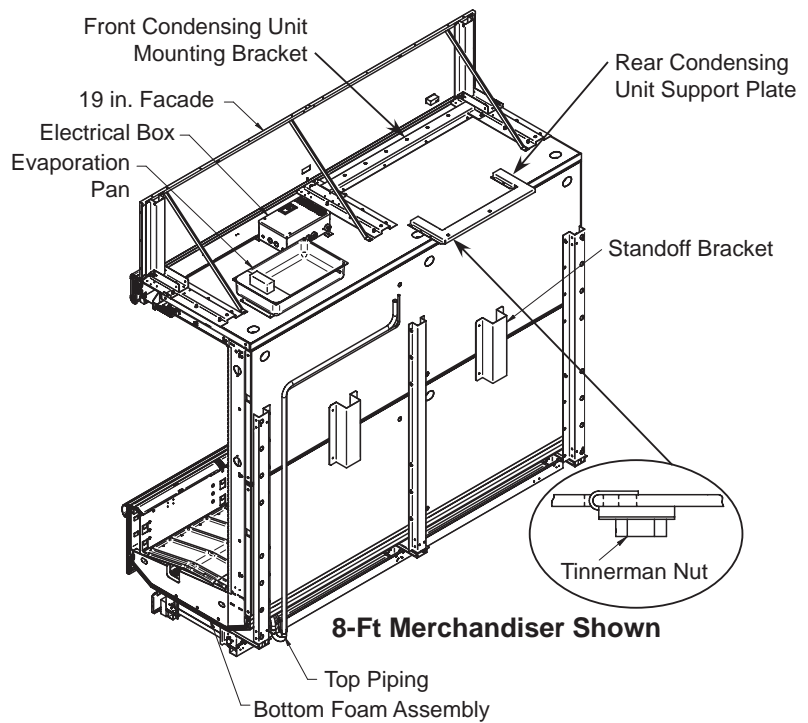
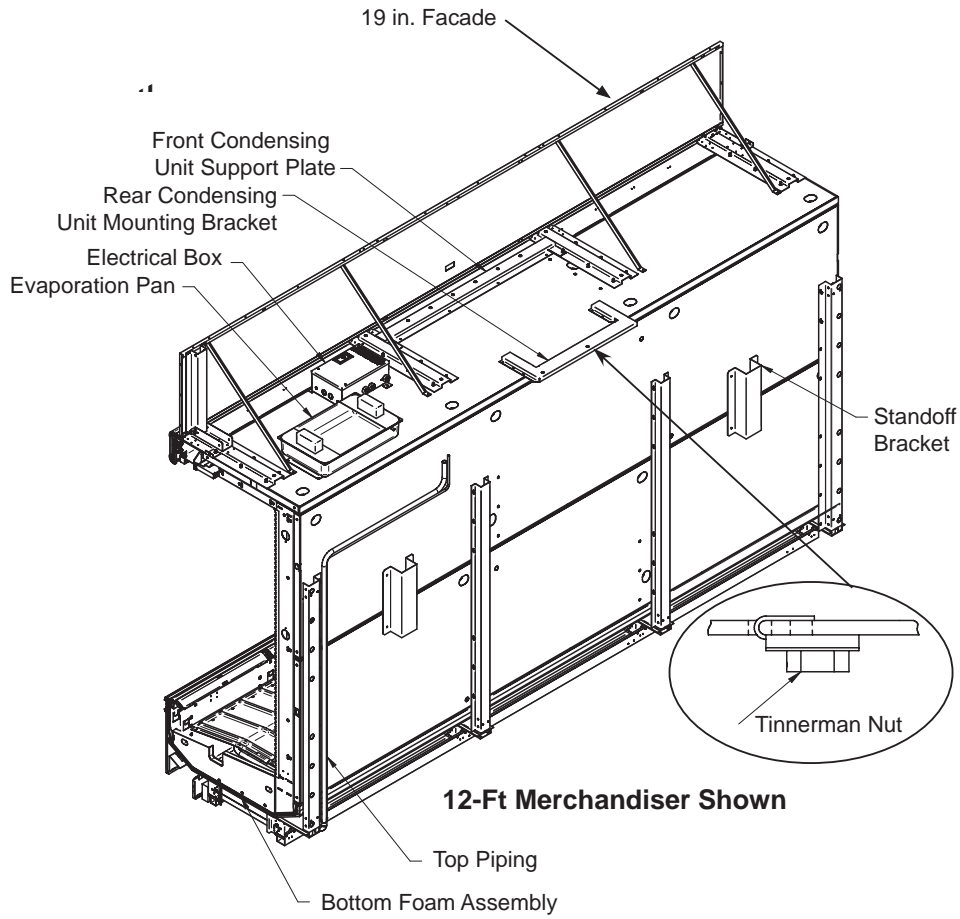

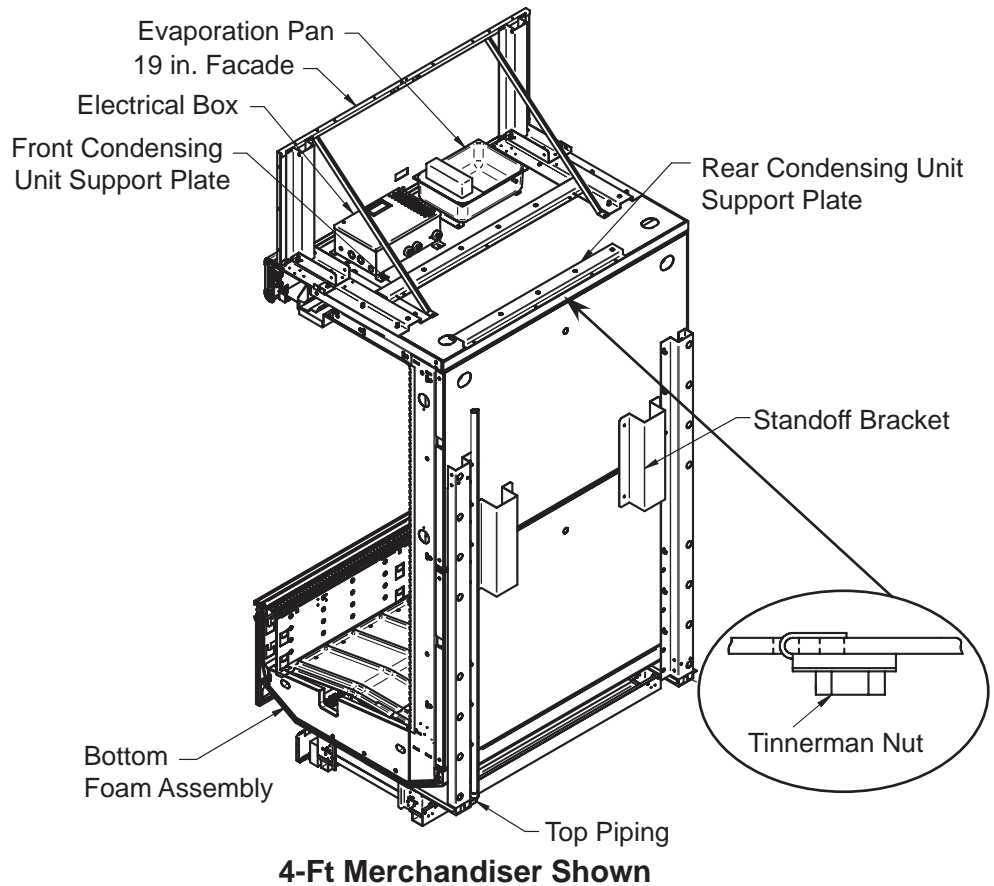
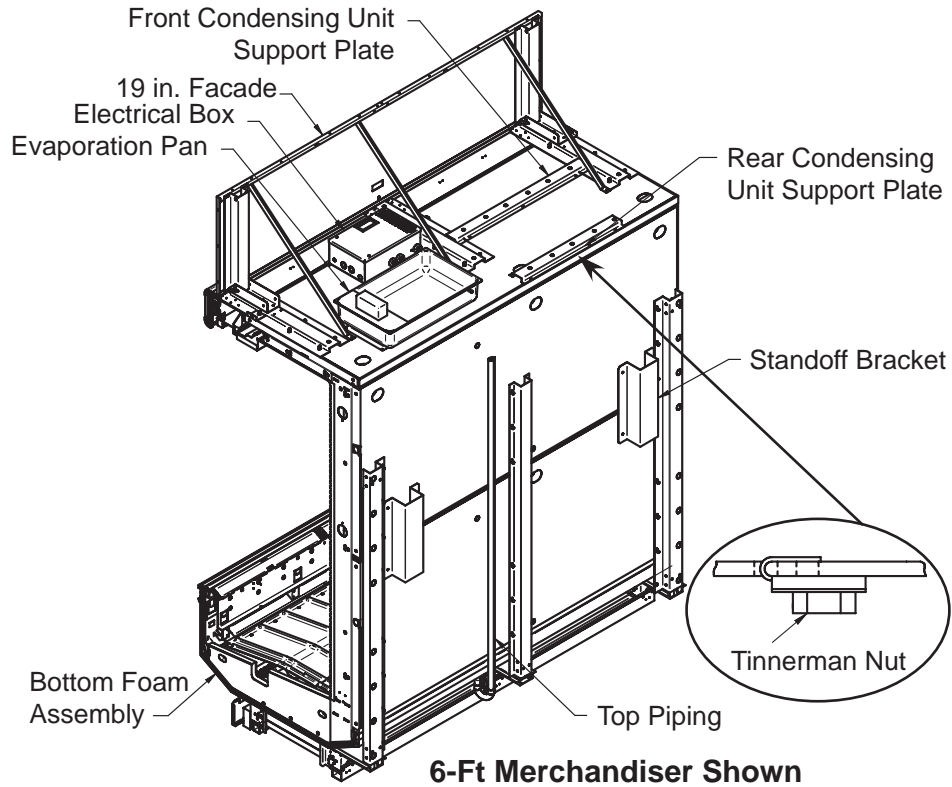

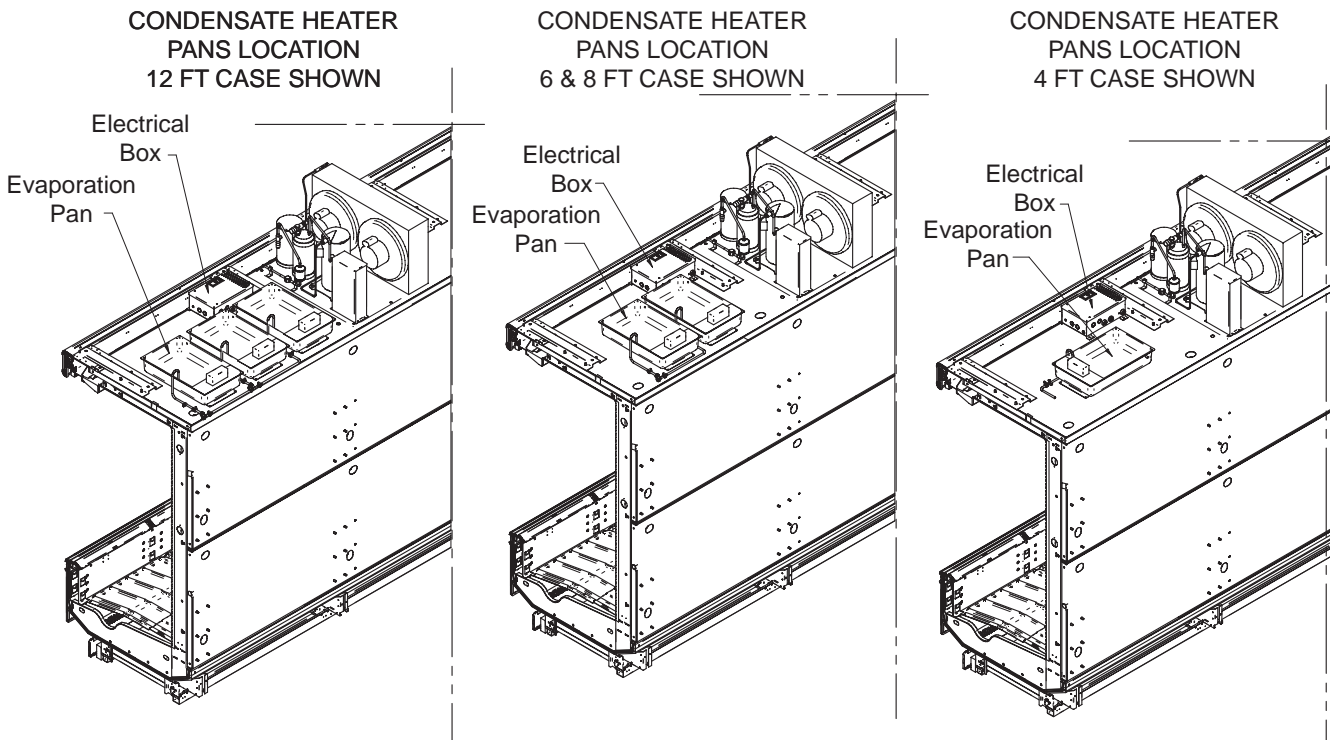

IMPORTANT: Pans must be installed level. Shim if needed.

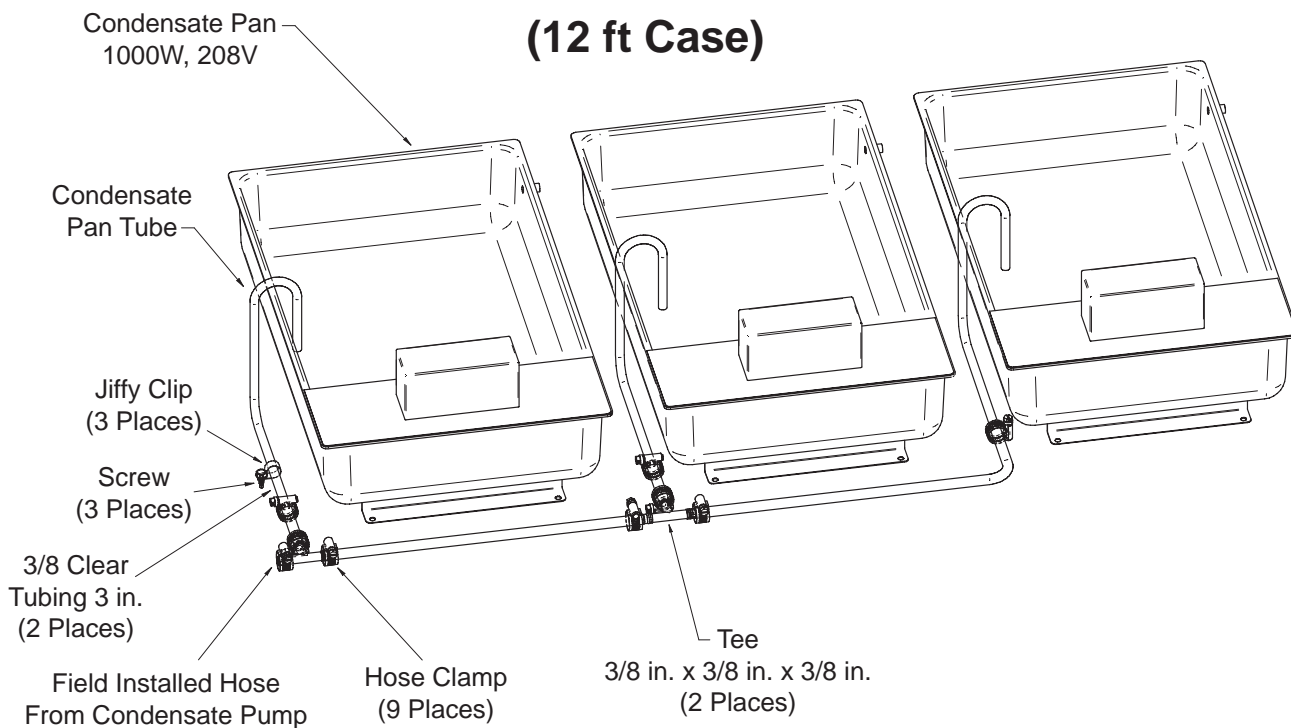

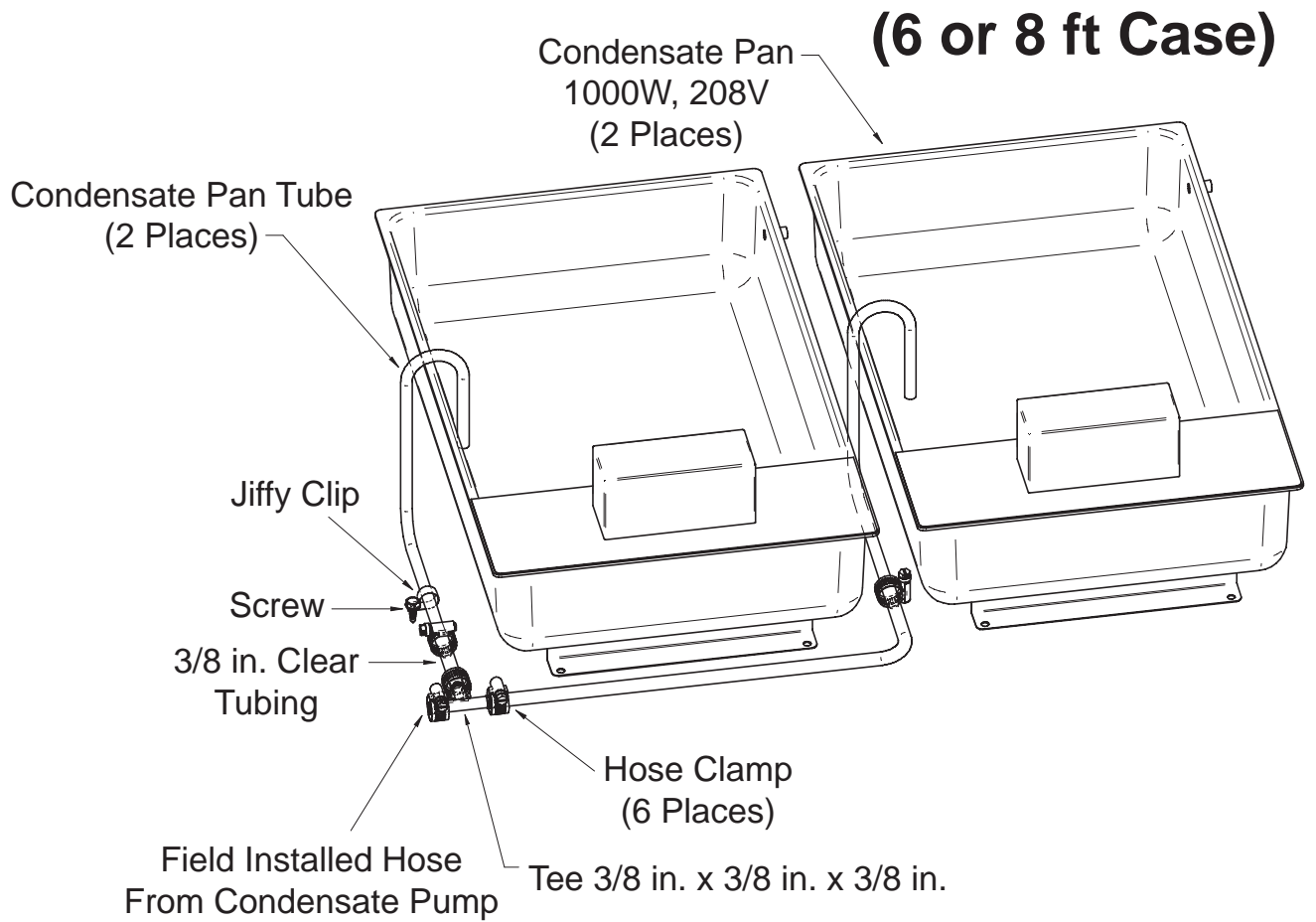

IMPORTANT: Pans must be installed level. Shim if needed.

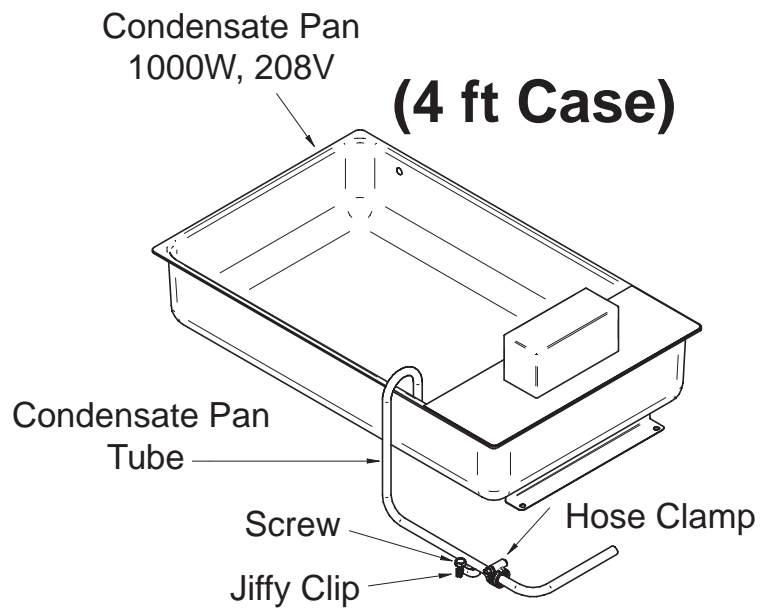

ABOUT QUICK CONNECT COUPLINGS

Quick Connect fittings are provided on both the case inlet and outlet lines, and on Hussmann's TCMXA404A, TCMXB404A, TCMXC404A and TCMXD404A series of condensing units. The case and condensing unit are pre-charged with the correct amount of refrigerant, and the lines are sealed.

Connecting the Quick Connects together breaks the seals to connect the refrigeration lines of the unit to the case. The Quick Connects must be properly torqued to avoid refrigerant leaks.

CONNECT LINES

Mount the suction line and liquid line to the condensing unit. When ready to connect, remove protector caps and plugs from the Quick Connect couplings. If necessary, carefully wipe coupling seats and threaded surfaces with a clean cloth to prevent the inclusion of dirt or any foreign material in the system. Lubricate male half diaphragm and synthetic rubber seal with refrigerant oil. Thread the coupling halves together by hand to ensure proper mating of threads. Use proper size wrenches (on coupling body hex and on union nut) and tighten until coupling bodies "bottom" or a definite resistance is felt.

INSULATE REFRIGERANT LINES

Suction lines are insulated to prevent condensation; extra insulation is provided to cover the field connected tubing sections. These exposed sections must be covered with insulation. Check that all suction lines are adequately covered with insulation, as some insulation may have been dislodged during shipping and installation. Avoid locating the tubing above the electrical box to prevent condensation from dripping onto electrical components.

USE A TORQUE WRENCH TO TIGHTEN THE QUICK CONNECT COUPLINGS TO THESE SETTINGS TO GET A LEAK-PROOF SEAL.

Coupling Size (inches)	Foot Pounds (Ft. Lbs.)
3/8	10-12
7/8	50-65



Outlet Quick Connect

Inlet Quick Connect

Inlet Quick Connect



Installation of Defrost Water Drain Line to Case Condensate Pump (Viewed from Front of Case with Shipping Brace Removed)

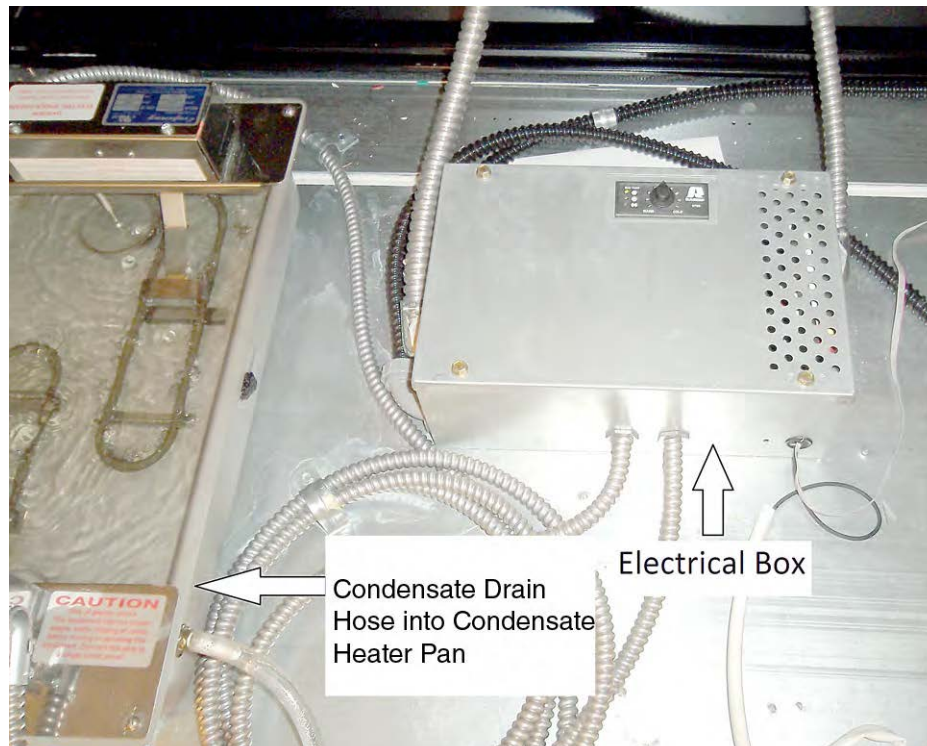
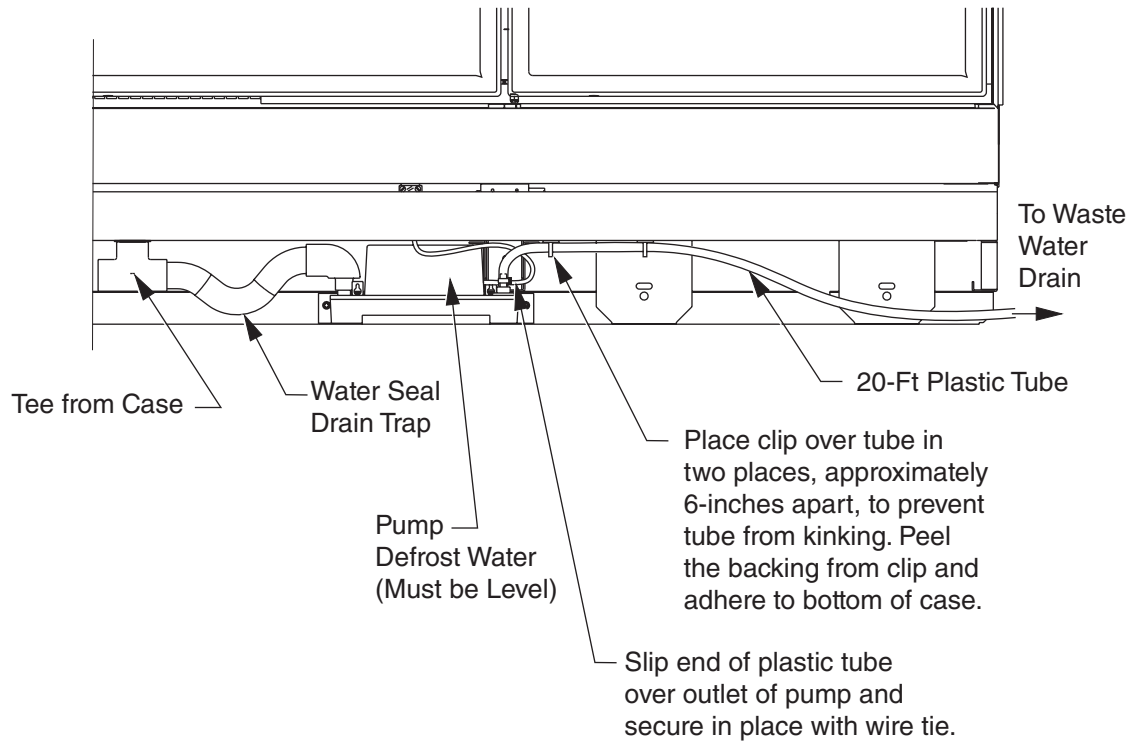

(OPTIONAL) CONDENSATE WATER PAN AND PUMP

The bottom drain for defrost water from the evaporator coil is connected to an evacuation pump which uses 3/8-inch plastic drain tubing to pump the water to the condensate pan on top of the case. The tubing should be inspected through its entire length to ensure that it has not been cut, kinked, obstructed, or damaged during shipping and installation.

The tees and elbows in the illustrations are to be fitted in the foam tube bottom of the merchandiser. The pump's tubing is then routed behind the case to the condensate pan on top of the case.

Item Number	Document Number	Title	Quantity
1	0516897	DEFROST WATER PUMP CP-22LP	1
2	0517512	ELBOW - 90 PVC .500 SOCKET X .750 FEMALE THREADED	2
3	0517513	FITTING - .750 MALE THREADED BARBED TUBE ADAPTER	2
4	0441771	CLAMP - 7/8 NYLON	4
5	0517511	PVC TUBING - PVC CLEAR FLEX ID .750 X 1.000 OD	2
6	0517514	FITTING - 1" MALE THREADED BARBED TUBE ADAPTER	2
7	0386604	BUSHING - REDUCER 1-1/4 X 1 IN	4
8	0448609	COUPLING - 1.25 X 1.25 PVC SCH 40	2
9	0423706	TRAP - DRAIN LOW TEMP ISL.	2
10	0393539	TEE - 1.250 SLP X SLP X SLP	2
11	0386605	PLUG - 1 IN THREADED	2

Item Number	Document Number	Title	Quantity
1	0516897	DEFROST WATER PUMP CP-22LP	1
2	0393539	TEE - 1.250 SLP X SLP X SLP	2
3	0525658	PIPE - 1.250 X 3.50 PVC SCH40	2
4	0525659	ELBOW 90, 1.25 DIA PVC SCH40	2
5	0423706	TRAP - DRAIN LOW TEMP ISL.	2
6	0448609	COUPLING - 1.25 X 1.25 PVC SCH 40	2
7	0517514	FITTING - 1" MALE THREADED BARBED TUBE ADAPTER	2
8	0517511	PVC TUBING - PVC CLEAR FLEX ID .750 X 1.000 OD	2
9	0441771	CLAMP - 7/8 NYLON	4
10	0517512	ELBOW - 90 PVC .500 SOCKET X .750 FEMALE THREADED	2
11	0517513	FITTING - .750 MALE THREADED BARBED TUBE ADAPTER	2
12	0386604	BUSHING - REDUCER 1-1/4 X 1 IN	2
13	0386605	PLUG - 1 IN THREADED	2

Defrost Water Pump 4ft

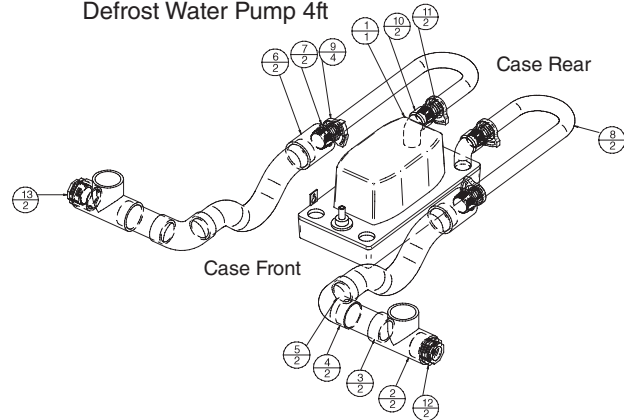

Defrost Water Pump 6ft

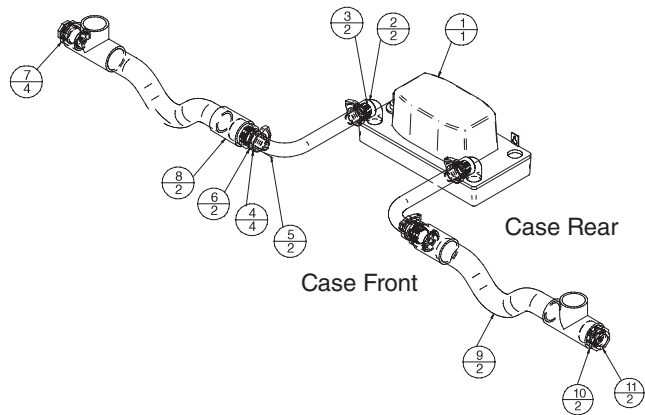

Item Number	Document Number	Title	Quantity
1	0516897	DEFROST WATER PUMP CP-22LP	1
2	0517512	ELBOW - 90 PVC .500 SOCKET X .750 FEMALE THREADED	2
3	0517513	FITTING - .750 MALE THREADED BARBED TUBE ADAPTER	2
4	0441771	CLAMP - 7/8 NYLON	4
5	0517511	PVC TUBING - PVC CLEAR FLEX ID .750 X 1.000 OD	2
6	0517514	FITTING - 1" MALE THREADED BARBED TUBE ADAPTER	2
7	0386604	BUSHING - REDUCER 1-1/4 X 1 IN	4
8	0448609	COUPLING - 1.25 X 1.25 PVC SCH 40	2
9	0423706	TRAP - DRAIN LOW TEMP ISL.	2
10	0393539	TEE - 1.250 SLP X SLP X SLP	2
11	0386605	PLUG - 1 IN THREADED	2
12	0525611	PIPE - 1.250 X 21.594 PVC	1

Defrost Water Pump 8ft

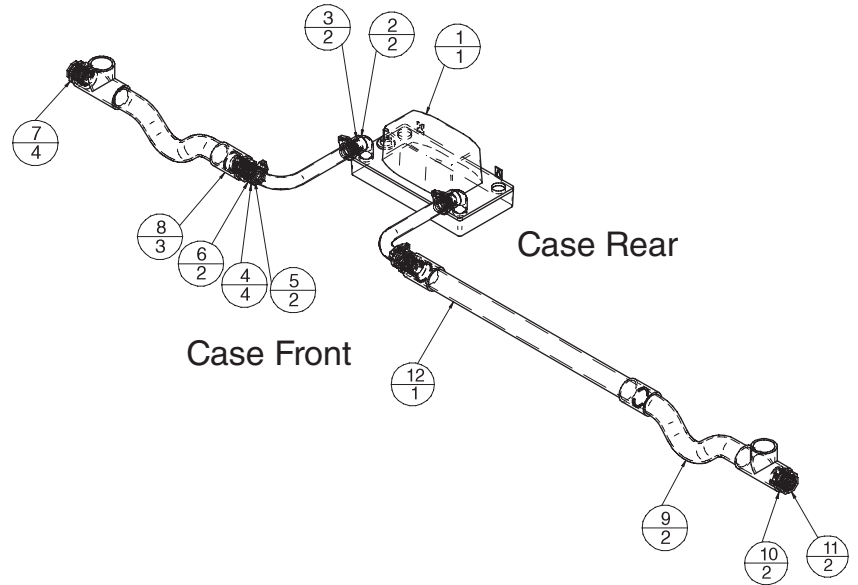



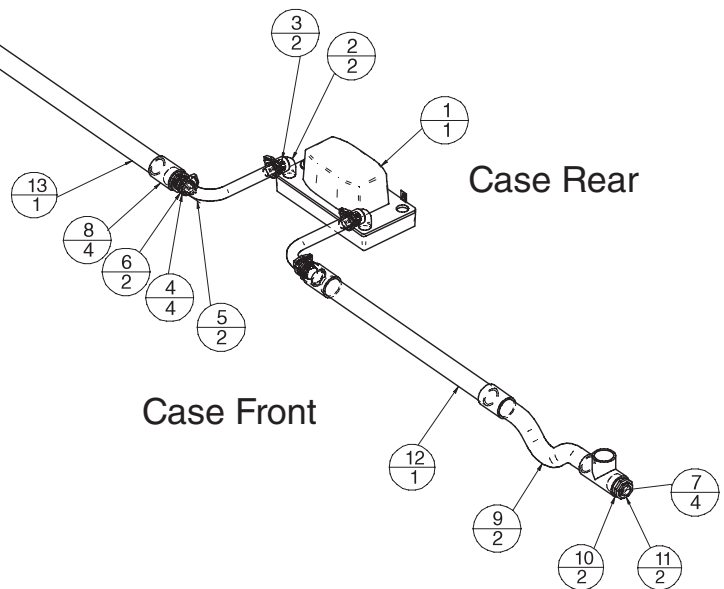

Defrost Water Pump 12ft



Item Number	Document Number	Title	Quantity
1	0516897	DEFROST WATER PUMP CP-22LP	1
2	0517512	ELBOW - 90 PVC .500 SOCKET X .750 FEMALE THREADED	2
3	0517513	FITTING - .750 MALE THREADED BARBED TUBE ADAPTER	2
4	0441771	CLAMP - 7/8 NYLON	4
5	0517511	PVC TUBING - PVC CLEAR FLEX ID .750 X 1.000 OD	2
6	0517514	FITTING - 1" MALE THREADED BARBED TUBE ADAPTER	2
7	0386604	BUSHING - REDUCER 1-1/4 X 1 IN	4
8	0448609	COUPLING - 1.25 X 1.25 PVC SCH 40	4
9	0423706	TRAP - DRAIN LOW TEMP ISL.	2
10	0393539	TEE - 1.250 SLP X SLP X SLP	2
11	0386605	PLUG - 1 IN THREADED	2
12	0525611	PIPE - 1.250 X 21.594 PVC	1
13	0524483	PIPE - 1.250 X 45.375 PVC	1



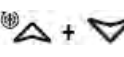





CONTROLLER OPERATION

Follow the tables to use the commands. The keypad display is located on the front of the merchandiser.

	Switches the device ON and OFF, if onF = oFF
	Switches the light ON and OFF, if oA1 = Lig
	Locks/Unlocks the keyboard
SET + 	To enter programming mode
SET + 	Returns to room temperature display

Key	Function
SET	Press to display target setpoint, to select a parameter in programming mode, or to confirm an operation
	Starts a manual defrost
	Press the UP arrow to see the MAX temperature, to browse the parameter codes in programming mode, or to increase the currently displayed temperature value.
	Press the DOWN arrow to see the MIN temperature, to browse the parameter codes in programming mode, or to decrease the currently displayed temperature value.

Follow the LED commands to operate and control the case's lighting.

LED	Mode	Function
	ON	Compressor enabled
	Flashing	Anti-short cycle delay enabled
	ON	Defrost enabled
	Flashing	Drip time in progress
	ON	Fans enabled
	Flashing	Fans delay after defrost in progress.
	ON	An alarm is occurring

All cases manufactured after August 2017, use the Dixell XR75 Controller. For cases manufactured before this date, refer to the Safe-NET III user instructions in Section 8 of this manual.

How to see the setpoint

1. Push and immediately release the SET key. The display will show the setpoint value.
2. Push and immediately release the SET key or wait for 5 seconds to display the present value again.

How to change the setpoint:

The controller is shipped from the factory with medium temperature product settings. Follow the instructions below to modify the setpoint temperature.

1. Push and hold the SET key for more than 2 seconds to change the setpoint value.
2. The value of the setpoint will be displayed and the °C or °F LED starts blinking.
3. To change the setpoint value push the UP or DOWN arrows within 10 seconds.
4. To memorize the new setpoint value, push the SET key again or wait 10 seconds.

How to start a manual defrost:

Push and hold the DEF key for more than 2 seconds and a manual defrost will start.

How to lock the keyboard:

1. Keep the UP + DOWN arrow keys pressed for more than 3 seconds.
2. The **PoF** message will be displayed and the keyboard will be locked. At this point it will be possible to see the setpoint of the MAX or Min temperature stored only.
3. If a key is pressed for more than 3 seconds the **PoF** message will be displayed.

WARNING

The optional evaporator fan remains ON when the adjustment knob is in the OFF position.

How to unlock the keyboard:

Press the UP and DOWN arrow keys together for more than 3 seconds until the Pon message displays.

Alarms:

- P1 Discharge temperature probe failure
- P2 Defrost termination probe failure
- HA Max temperature alarm
- LA Min temperature alarm

How to set defrost start time

For cases with doors:

Defrost occurs 24 hours after startup, then will take place every 24 hours

For open cases (without doors):

Defrost occurs 6 hours after startup, then defrost will take place every 6 hours.

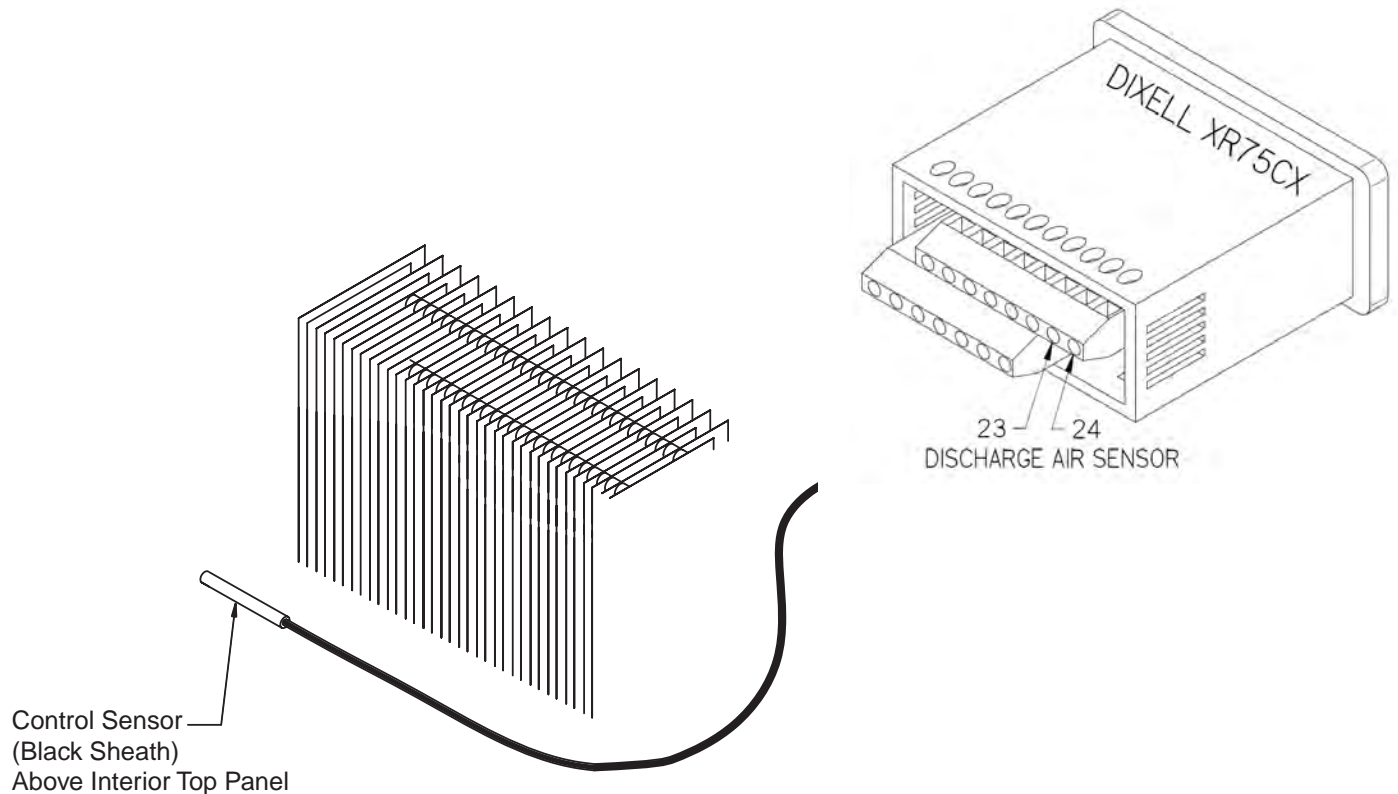
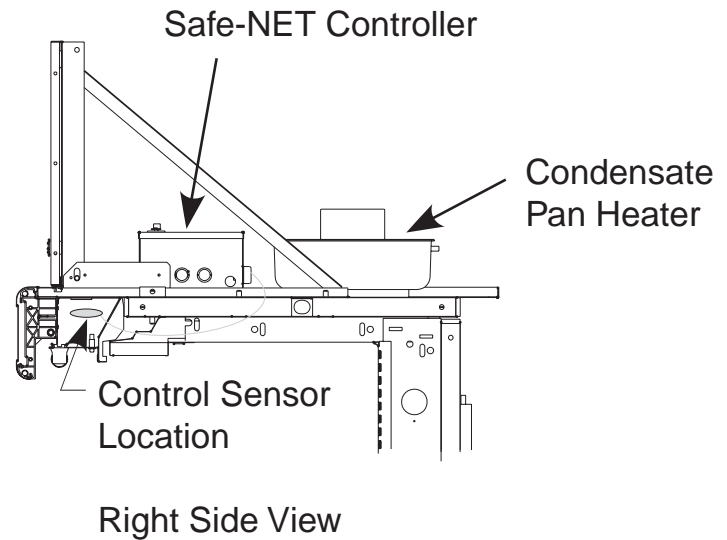

CONTROLS and ADJUSTMENTS

Refrigeration Controls			Defrost Controls			
Model	Product Application	Discharge Air Temperature	Defrost Frequency (per day)	Type of Defrost	Termination Temperature	Failsafe Time (Minutes)
CF5X	Medium Temp. (Dairy, Deli, Produce)	32° F	4	Off Time	48° F	45
DF5NX	Medium Temp. (Dairy, Deli)	31° F	4	Off Time	48° F	45
DDF5NX	Medium Temp. (Dairy, Deli)	38° F	1	Off Time	40° F	50

1. The controller controls refrigeration temperature. This is factory installed in the control panel. Adjust this control keypad to maintain the discharge air temperature shown. Measure discharge air temperatures at the center of the honeycomb.

To ensure a thorough defrost, the defrost must be terminated by the temperature termination setting — not by time.

For medium temperature models, defrost is time initiated and time terminated.

EMERSON PRESSURE CONTROL ADJUSTMENT SETTING

Locate the Emerson Electronic Unit Controller pressure safety control located on the Copeland Condensing Unit. Follow the instructions shown on the Emerson EUC, check and adjust the LOW and HIGH side settings. Recommended settings for R-404A refrigerant are: LOW side cut-out is 10 psig, cut-in is 25 psig. HIGH side cut-out is 350 psig.



CAUTION

Blocked drain lines will cause water to back up in the case and spill onto the floor, causing a slip hazard.

ALWAYS CHECK THE SERIAL PLATE FOR COMPONENT AMPERES.

Electric Defrost is standard for low temperature merchandisers and requires temperature termination. Off Time Defrost is standard for medium temperature merchandisers and is time terminated.

MERCHANDISER ELECTRICAL DATA

Merchandiser data sheets for specific models are shipped with this manual. The data sheets provide merchandiser electrical data, standard electrical schematics, parts lists and performance data. *Refer to the merchandiser data sheets and merchandiser serial plate for electrical information. Refer to the separate wiring diagrams shipped with the case for specific information about the merchandiser and any optional wiring kits that may have been applied.*

ELECTRICAL CONNECTIONS

All wiring must be in compliance with NEC and local codes.

 **WARNING**
Terminal block **NOT** for case-to-case wire connection.

IDENTIFICATION OF WIRING

Leads for all electrical circuits are identified by colored plastic bands. These bands correspond to the color code sticker (shown below) located inside the merchandiser wireway.

...ATTENTION INSTALLER
It is the contractor's responsibility to install merchandiser(s) in accordance with all local building and health codes.

WIRING COLOR CODE

Leads for all electrical circuits are identified by a colored plastic band: neutral wire for each circuit has either White insulation or a White plastic sleeve in addition to the color band.

PINK REFRIG. THERMOSTAT LOW TEMP.	ORANGE OR
LIGHT BLUE . REFRIG. THERMOSTAT NORM TEMP.	TANLIGHTS
DARK BLUE . DEFROST TERM. THERMOSTAT	MAROON ..RECEPTACLES
PURPLE ANTI-SWEAT HEATERS	YELLOW* ..DEFROST HEATERS, 120V
BROWN FAN MOTORS	RED*DEFROST HEATERS, 208V
GREEN* GROUND	

*EITHER COLORED SLEEVE OR COLORED INSULATION
ELECTRICIAN NOTE: Use copper conductor wire only.
CASE MUST BE GROUNDED

THESE ARE MARKER COLORS WIRES MAY VARY.

Wiring Diagrams

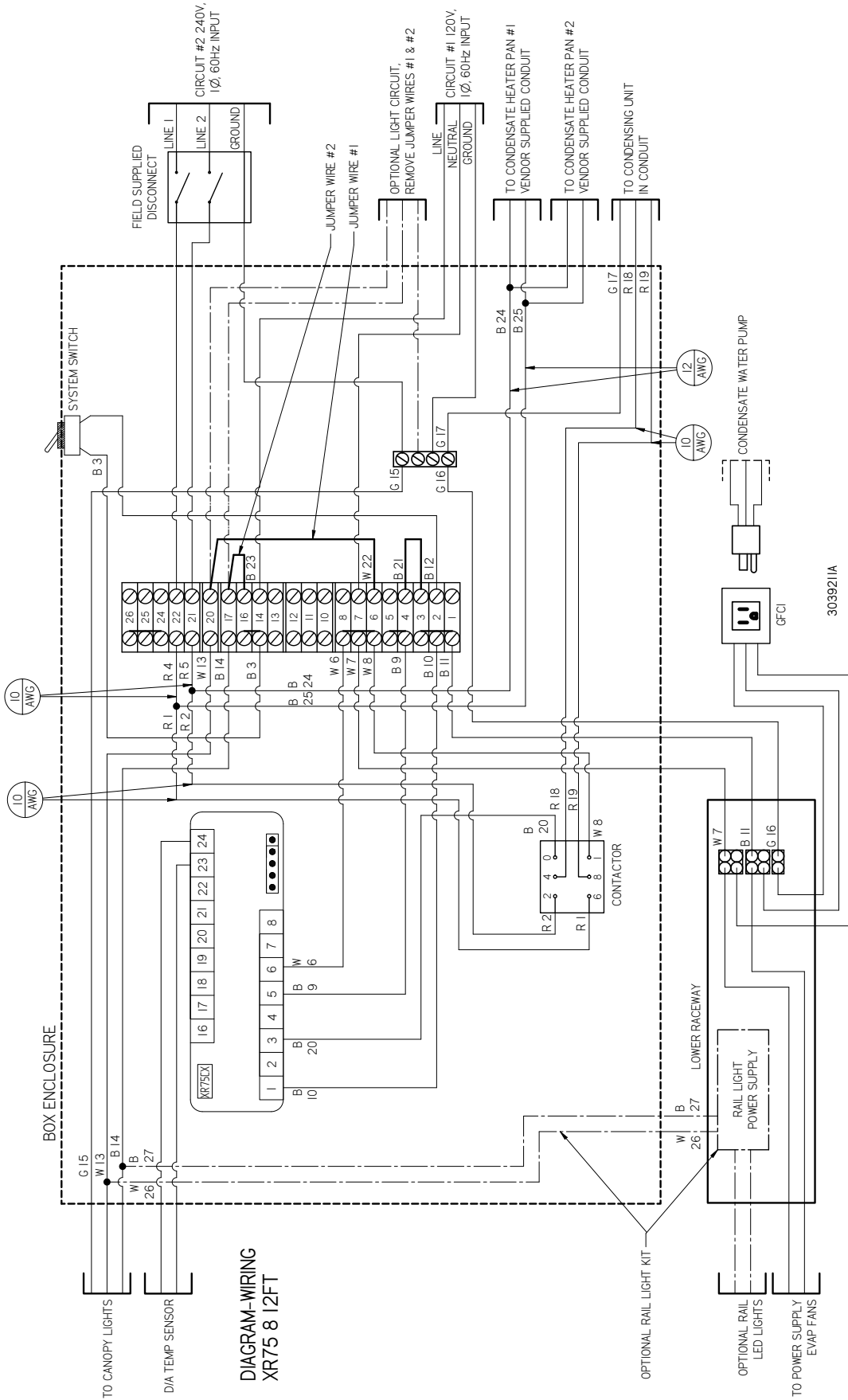

WARNING

All components must have mechanical ground, and the merchandiser must be grounded.

Circled numbers = Parts list item Numbers

R = Red Y = Yellow G = Green B = Blue BK = Black W = White

● = 120V Power ○ = 120V Neutral ⊥ = Field Ground ≡ = Case Ground

Wiring Diagrams

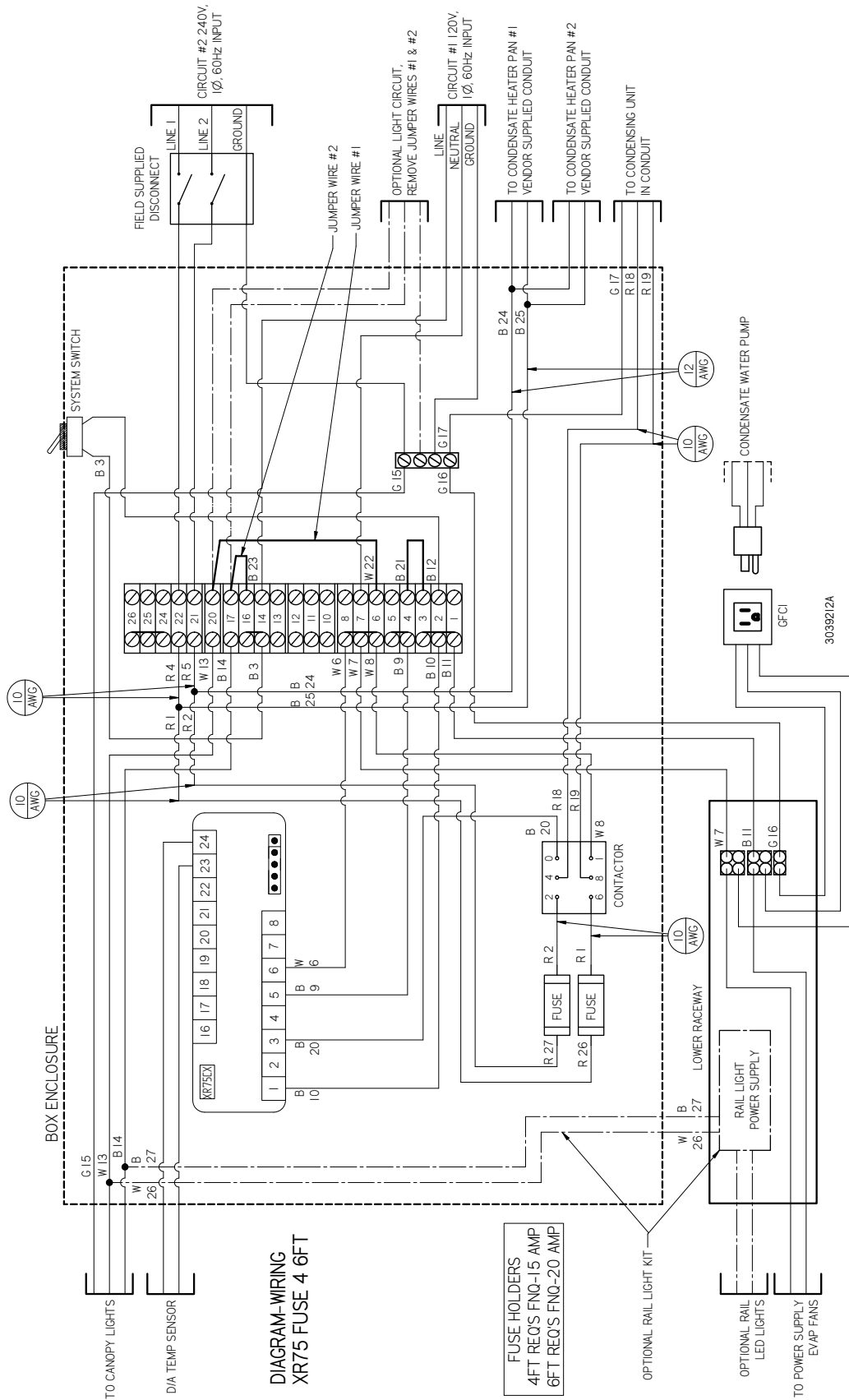

WARNING

All components must have mechanical ground, and the merchandiser must be grounded.

Circled numbers = Parts list Item Numbers

R = Red Y = Yellow G = Green BL = Blue BK = Black W = White

● = 120V Power ○ = 120V Neutral ⊥ = Field Ground ≡ = Case Ground

Controller Parameters

Dixell XR75						
XR 75 Code	XR 75 Parameter	XR 75 Function	XR 75 Default	DF5NX	CF5X	DDF5NX
SEt	Temperature Setpoint	LS to US	-5	31	32	38
REGULATION						
Hy	Differential	(0.1 to 25.5°C / 1 to 255°F) Intervention differential for setpoint. Compressor Cut IN is setpoint + differential (Hy). Compressor Cut OUT is when the temperature reaches the setpoint.	2	4	4	4
LS	Minimum setpoint	(-100°C to SEt/-148°F to SEt) Sets the minimum value for the setpoint.	-50	24	23	31
US	Maximum setpoint	(SEt to 110°C/ SEt to 230°F) Set the maximum value for the setpoint.	110	38	38	45
ot	Thermostat probe calibration	(-12.0 to 12.0°C; -120 to 120°F) Allows to adjust possible offset of the thermostat probe.	0	0	0	0
P2P	Evaporator probe presence	n = not present: the defrost stops by time y = present: the defrost stops by temperature	Y	n	n	n
oE	Evaporator probe calibration	(-12.0 to 12.0°C; -120 to 120°F) Allows to adjust possible offset of the evaporator probe.	0	0	0	0
P3P	Third probe presence (P3)	n = not present; the terminals 18-20 operate as digital input y = present; the terminals 18-20 operate as third probe	n	n	n	n
o3	Third probe calibration (P3)	(-12.0 to 12.0°C; -120 to 120°F) Allows to adjust possible offset of the third probe.	0	0	0	0
P4P	Fourth probe presence	(n = not present; y = present)	n	n	n	n
o4	Fourth probe calibration	(-12.0 to 12.0°C) Allows to adjust possible offset of the fourth probe.	0	0	0	0
Ods	Outputs activation delay at startup	(0 to 255 min) This function is enabled at the initial start up of the device and inhibits any output activation for the period of time set in the parameter.	0	0	0	0
Ac	Anti-short cycle delay	(0 to 50 min) Minimum interval between the compressor stop and the following restart.	1	2	2	2
rtr	Percentage of the second and first probe for regulation (0 to 100; 100 = P1, 0 = P2)	Allows to set the regulation according to the percentage of the first and second probe, as for the following formula (rtr(P1-P2)/100 + P2).	100	100	100	100
CCt	Compressor ON time during continuous cycle	(0.0 to 24.0 hr; res. 10 min) Allows to set the length of the continuous cycle: compressor stays ON without interruption for the CCT time. Can be used, for instance, when the room is filled with new products.	0	0	0	0
CCS	Setpoint for continuous cycle	(-100 to 150°C) Sets the setpoint used during the continuous cycle.	-5	31	32	38
Con	Compressor ON time with faulty probe	(0 to 255 min) Time during which the compressor is active in case of faulty thermostat probe. With Con = 0, compressor is always OFF.	15	3	3	3
CoF	Compressor OFF time with faulty probe	(0 to 255 min) Time during which the compressor is OFF in case of faulty thermostat probe. When CoF = 0, compressor is always active.	30	2	2	2
CF	Temperature measurement unit	°C = Celsius, °F = Fahrenheit, (CAUTION! When the measurement unit is changed, the setpoint and the values of the parameters Hy, LS, US, ot, ALU and ALL have to be checked and modified if necessary).	C	F	F	F
rES	Resolution (for °C)	(in = 1°C; dE = 0.1°C) Allows decimal point display.	dE	dE	dE	dE
Lod	Device display	(P1; P2, P3, P4, SEt, dtr) Selects which probe is displayed by the device: P1 = Thermostat probe P2 = Evaporator probe; P3 = Third probe (only for models with this option enabled), P4 = Fourth probe, SEt = setpoint, dtr = percentage of visualization	P1	P1	P1	P1
Red	X- REP display (optional)	(P1; P2, P3, P4, SEt, dtr) Selects which probe is displayed by the device: P1 = Thermostat probe P2 = Evaporator probe; P3 = Third probe (only for models with this option enabled), P4 = Fourth probe, SEt = setpoint, dtr = percentage of visualization	P1	P1	P1	P1
dLy	Display delay	(0 to 20.0 min; resul. 10 seconds) When the temperature increases, the display is updated of 1°C/1°F after this time.	0	0	0	0
dtr	Percentage of the second and first probe for visualization when Lod = dtr (0 to 100; 100 = P1, 0 = P2)	If Lod = dtr, it allows to set the visualization according to the percentage of the first and second probe, as for the following formula (dtr(P1-P2)/100 + P2).	50	100	100	100
DEFROST						
EdF	Defrost mode (only for controller with RTC)	rtC = Real Time Clock mode. Defrost time follows Ld1 to Ld6 parameters on workdays and Sd1 to Sd6 on holidays. in = interval mode. The defrost starts when the time IdF is expired.	rtC	in	in	in
tdF	Defrost type	EL = electrical heater in = hot gas	EL	EL	EL	EL
dFP	Probe selection for defrost termination	nP = no probe P1 = thermostat probe P2 = evaporator probe P3 = configurable probe P4 = probe on Hot Key plug	P2	P1	P1	P1
dtE	Defrost termination temperature	(-50 to 50°C / -58 to 122°F) (Enabled only when EdF = Pb) Sets the temperature measured by the evaporator probe, which causes the end of defrost.	8	48	48	40
IdF	Interval between defrost cycles	(0 to 120 hr) Determines the time interval between the beginning of two defrost cycles.	6	6	6	24
MdF	(Maximum) length for defrost	(0 to 255 min) When P2P = n, (not evaporator probe: timed defrost) it sets the defrost duration, when P2P = y (defrost end based on temperature) it sets the maximum length for defrost.	30	45	45	50
dSd	Start defrost delay	(0 to 99 min) This is useful when different defrost start times are necessary to avoid overloading the plant.	0	0	0	0
dFd	Temperature displayed during defrost	(rt = real temperature; it = temperature at defrost start; SEt = setpoint; dEF = dEF la-bel)	it	Def	Def	Def
dAd	MAX display delay after de-frost	(0 to 255 min) Sets the maximum time between the end of defrost and the restarting of the real room temperature display.	30	30	30	30
Fdt	Drip time	(0 to 120 min) Time interval between reaching defrost termination temperature and the restoring of the controllers normal operation. This time allows the evaporator to eliminate water drops that might have formed due to defrost.	0	0	0	0
dPo	First defrost after start-up	(y = immediately; n = after the IdF time)	n	n	n	n
dAF	Defrost delay after continuous cycle	(0 to 23.5 hr) Time interval between the end of the fast freezing cycle and the following defrost related to it.	0	0	0	0

Controller Parameters

FANS						
FnC	Fans operating mode	C-n = runs with the compressor, OFF during defrost O-n = continuous mode, OFF during defrost C-y = runs with the compressor, ON during defrost O-y = continuous mode, ON during defrost	O-n	O-y	O-y	O-y
Fnd	Fans delay after defrost	(0 to 255 min) Interval between end of defrost and evaporator fans start	10	0	0	0
FCT	Temperature differential avoiding short cycles of fans	(0 to 59°C; FCT = 0 function disabled) If the difference in temperature between the evaporator and the room probes is more than the value of the FCT parameter, the fans are switched ON.	10	0	0	0
FSt	Fans stop temperature	(-50 to 50°C/ 122°F) Setting of temperature, detected by the evaporator probe, above which fans are always OFF.	2	2	2	2
Fon	Fan ON time	(0 to 15 min) With Fnc=C_n or C_y, (fan activated in parallel with compressor). Sets the evaporator fan ON cycling time when the compressor is OFF. When Fon=0 and FoF not equal to 0, the fans are always OFF, with Fon=0 and FoF=0, the fans are always OFF.	0	0	0	0
FoF	Fan OFF time	(0 to 15 min) With Fnc=C_n or C_y, (fan activated in parallel with compressor). Sets the evaporator fan OFF cycling time when the compressor is OFF. When Fon=0 and FoF not equal to 0, the fans are always OFF, when Fon=0 and FoF=0, the fans are always OFF.	0	0	0	0
FAP	Probe selection for fan management	nP = no probe P1 = thermostat probe P2 = evaporator probe P3 = configurable probe P4 = probe on Hot Key plug	P2	nP	nP	nP
AUXILIARY THERMOSTAT CONFIGURATION (terms. 1-4) - oA3 = AUS						
ACH	Kind of regulation for auxiliary relay	Ht = heating CL = cooling	CL	CL	CL	CL
SAA	Setpoint for auxiliary relay	(-100 to 150.0°C; -148 to 302°F) Defines the room temperature setpoint to switch auxiliary relay.	0	0	0	0
Shy	Differential for auxiliary output	(0.1 to 25.5°C/ 1 to 255°F) Intervention differential for auxiliary output setpoint. When ACH = CL, AUX Cut in is SAA + SHY; AUX Cut out is SAA When ACH = Ht, AUX Cut in is SAA - SHY; AUX Cut out is SAA	2	2	2	2
ArP	Probe selection for auxiliary	nP = no probe, the auxiliary relay is switched only by the digital input P1 = Probe 1 (thermostat probe) P2 = Probe 2 (evaporator probe) P3 = Probe 3 (display probe) P4 = Probe 4	nP	nP	nP	nP
Sdd	Auxiliary relay OFF during defrost	n = the auxiliary relay operates during defrost y = the auxiliary relay is switched OFF during defrost	n	n	n	n
ALARMS						
ALP	Probe selection for alarm	nP = no probe, the temperature alarms are disabled P1 = Probe 1 (thermostat probe) P2 = Probe 2 (evaporator probe) P3 = Probe 3 (display probe) P4 = Fourth probe	P1	P1	P1	P1
ALC	Temperature alarms configuration	(Ab; rE) Ab = absolute temperature: alarm temperature is given by the ALL or ALU values. rE = temperature alarms are referred to the setpoint. Temperature alarm is enabled when the temperature exceeds the SET + ALU or SET - ALL values.	Ab	Ab	Ab	Ab
ALU	Maximum temperature alarm	(SET to 150°C; SET to 302°F) When this temperature is reached, the alarm is enabled, after the ALd delay time.	110	48	48	48
ALL	Minimum temperature alarm	(-100 to SET; -148°C to 230°F) When this temperature is reached, the alarm is enabled, after the ALd delay time.	-50	20	20	27
AFH	Differential for temperature alarm recovery	(0.1 to 25.5°C; 1 to 45°F) Intervention differential for recovery of temperature alarm. It is also used for the restart of the fan when the FSt temperature is reached.	2	4	4	4
ALd	Temperature alarm delay	(0 to 255 min) Time interval between the detection of an alarm condition and alarm signaling.	15	30	30	30
dAo	Exclusion of temperature alarm at start-up	(from 0.0 min to 23.5 hr) Time interval between the detection of the temperature alarm condition after device power ON and alarm signaling.	1.3	2	2	2
CONDENSER TEMPERATURE ALARM						
AP2	Probe selection for temperature alarm of condenser	nP = no probe P1 = thermostat probe P2 = evaporator probe P3 = configurable probe P4 = probe on Hot Key plug	P4	nP	nP	nP
AL2	Low temperature alarm of condenser	(-100 to 150°C) When this temperature is reached, the LA2 alarm is signaled, possibly after the Ad2 delay.	-40	-40	-40	-40
AU2	High temperature alarm of condenser	(-100 to 150°C) When this temperature is reached, the HA2 alarm is signaled, possibly after the Ad2 delay.	110	110	110	110
AH2	Differential for temperature condenser alarm recovery	(0.1 to 25.5°C; 1 to 45°F)	5	52	52	52
Ad2	Condenser temperature alarm delay	(0 to 255 min) Time interval between the detection of the condenser alarm condition and alarm signaling.	15	15	15	15
dA2	Condenser temperature alarm exclusion at start up	(from 0.0 min to 23.5 hr, res. 10 min)	1.3	1.3	1.3	1.3
bLL	Compressor OFF with low temperature alarm of condenser	n = no: compressor keeps on working Y = yes, compressor is switched OFF until the alarm is present, in any case regulation restarts after Ac time at minimum.	n	n	n	n
AC2	Compressor OFF with high temperature alarm of condenser	n = no: compressor keeps on working Y = yes, compressor is switched OFF until the alarm is present, in any case regulation restarts after Ac time at minimum.	n	n	n	n
AUXILIARY RELAY						
tbA	Alarm relay silencing (with oA3=ALr)	n = silencing disabled: alarm relay stays ON until alarm condition lasts y = silencing enabled: alarm relay is switched OFF by pressing a key during an alarm	y	Y	Y	Y
oA3	Fourth relay configuration (1-4)	dEF, FAn: do not select it! ALr: alarm; Lig: light; AUS: Auxiliary relay; onF: always ON with device ON; db = neutral zone; cP2 = do not select it!; dEF2: do not select it!; HES: night blind	Lig	Alr	Alr	ALR
AOP	Alarm relay polarity	Set if the alarm relay is open or closed when an alarm happens. CL = terminals 1-4 closed during an alarm oP = terminals 1-4 open during an alarm	CL	CL	CL	CL
DIGITAL INPUTS						
i1P	Digital input polarity (18-20)	oP = the digital input is activated by opening the contact CL = the digital input is activated by closing the contact	CL	CL	CL	CL
i1F	Digital input configuration (18-20)	dor = door switch function dEF = activation of a defrost cycle	dor	dor	dor	dor
i2P	2nd digital input polarity (18-19)	oP = the digital input is activated by opening the contact CL = the digital input is activated by closing the contact	CL	CL	CL	CL
i2F	2nd digital input configuration (18-19)	EAL = external alarm: "EA" message is displayed bAL = serious alarm "CA" message is displayed PAL = pressure switch alarm, "CA" message is displayed dor = door switch function dEF = activation of a defrost cycle ES = energy saving AUS = auxiliary relay activation with oA3 = AUS Htr = kind of action inversion (cooling - heating) FAn = fan HdF = Holiday defrost (enable only with RTC) onF = to switch the controller OFF	EAL	EAL	EAL	EAL

Controller Parameters

did	(0 to 255 min) with i2F= EAL or i2F = bAL digital input alarm delay (18-20)	Delay between the detection of the external alarm condition and its signaling. When i2F= PAL: time for pressure switch function: time interval to calculate the number of the pressure switch activation.	15	15	15	15
doA	Door open signaling delay	(0 to 255 min)	15	15	15	15
nPS	Pressure switch number	(0 to 15) Number of activation of the pressure switch, during the did interval, before signaling the alarm event (i2F = PAL). If the nPS activation in the did time is reached, switch OFF and ON the device to restart normal regulation.	15	15	15	15
Odc	Compressor status when open door	no = normal Fan = fan OFF CPr = compressor OFF F_C = compressor and fan OFF	F-C	F-C	F-C	F-C
rrd	Outputs restart after doA alarm	no = outputs not affected by the doA alarm yES = outputs restart with the doA alarm	y	y	y	y
HES	Temperature increase during the Energy Saving cycle	(-30.0°C to 30.0°C) Sets the increasing value of the setpoint during the Energy Saving cycle.	0	0	0	0
OTHER PARAMETERS						
Adr	Serial address (1 to 244)	Identifies the device address when connected to a MODBUS compatible monitoring system.	1	1	1	1
pbC	Type of probe	Allows to set the kind of probe used by the device: Pt1 = Pt1000 probe ntc = NTC probe	ntc	ctc	ctc	ctc
onF	ON/OFF key enabling	not used = disabled oFF = enabled ES = not set it				
dP1	Thermostat probe display					
dP2	Evaporator probe display					
dP3	Third probe display - optional					
dP4	Fourth probe display					
rSE	Real setpoint	Shows the setpoint used during the energy saving cycle or during the continuous cycle.				
rEL	Software release	For internal use only				
Ptb	Parameter table code	Read-only				

DRIP PIPING / FACADES / SPLASHGUARDS / BUMPERS

WASTE OUTLET AND WATER SEAL

Each merchandiser has two waste outlets. The waste outlets are located in front of the fan plenum 12 inches (305 mm) from either end of the merchandiser. One water seal, two tees, and two clean-outs are supplied for each fixture. The water seal must be installed with the waste outlets to prevent air leakage and insect entrance into the merchandiser.

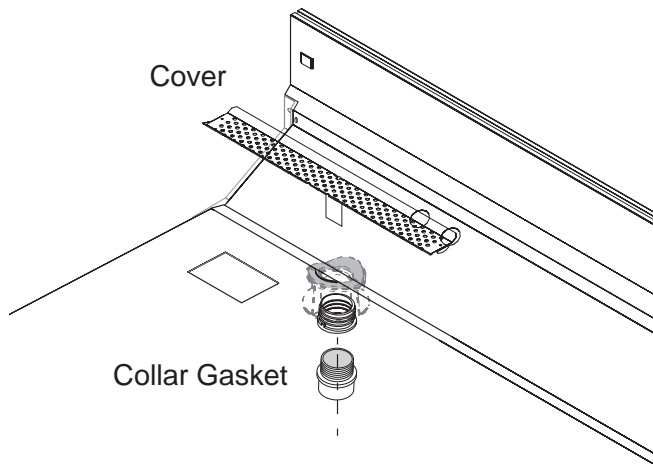

Items Factory Installed for Excel Waste Outlet on Each End of Case

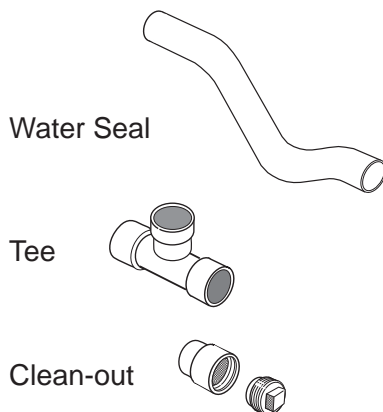

Factory Furnished Items To Be Installed

CAUTION

Splashguard brackets MUST be installed before piping merchandiser.

INSTALLING DRIP PIPING

Poorly or improperly installed drip pipes can seriously interfere with the merchandiser's operation and result in costly maintenance and product losses.

Optional drip pipe arrangements are shown on the next page. It is the installing contractor's responsibility to consult local agencies for local code requirements. Assemble the components using field-supplied PVC primer and glue according to the manufacturer's direction.

Please follow the recommendations listed below when installing drip pipes to ensure proper installation.

1. Never use drip piping smaller than the nominal diameter of the pipe or water seal supplied with the merchandiser.
2. When connecting drip piping, the "water seal" must be used as part of the drip piping to prevent air leakage or insect entrance. Never use two water seals in series in any one drip pipe. **DOUBLE WATER SEALS IN SERIES WILL CAUSE AN AIR LOCK AND PREVENT DRAINING.**
3. Pitch the drip piping in the direction of flow. **There should be a minimum pitch of 1/4 in. per ft (20 mm per 1 m).**
4. Avoid long runs of drip piping. Long runs make it impossible to provide the pitch necessary for good drainage.

5. Ensure that drip piping is supported to relieve any stress on drip pipe connectors and drain hub.

a. Drip piping **MUST** be supported no more than 24 in. from drain hub tee.

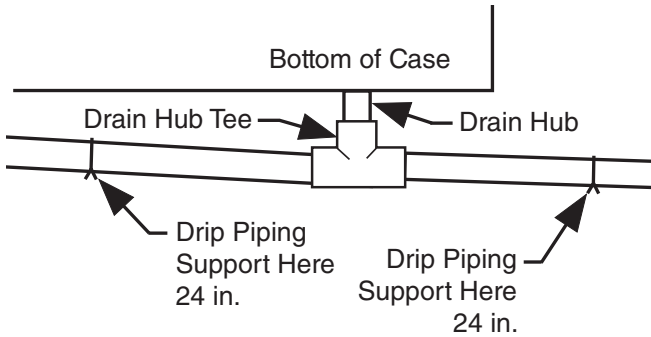

... ATTENTION INSTALLER

It is the installing contractor's responsibility to consult local agencies for local code requirements.

6. Provide a suitable air break between flood rim of the floor drain and outlet of drip pipe. To meet code on low base merchandisers, it may be necessary to install a field-supplied drip pipe reducer. An alternative is to cut the last section of drip pipe at an angle.



7. Prevent drip pipes from freezing:

a. Do NOT install drip pipes in contact with uninsulated suction lines. Suction lines should be insulated with a nonabsorbent insulation material.

b. Where drip pipes are located in dead air spaces, such as between merchandisers or between a merchandiser and a store wall, provide means to prevent freezing.

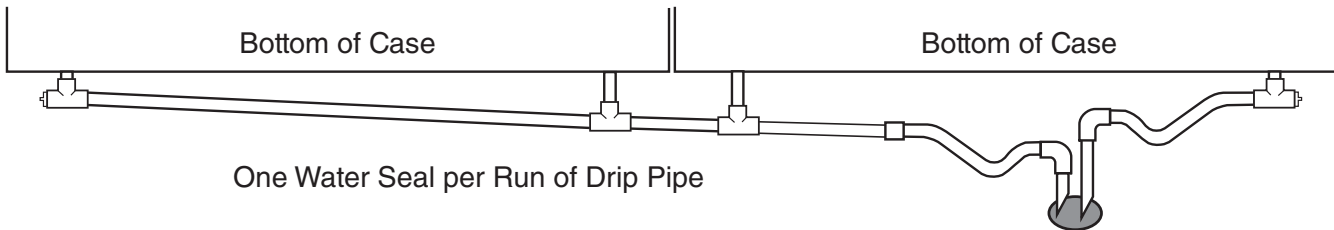
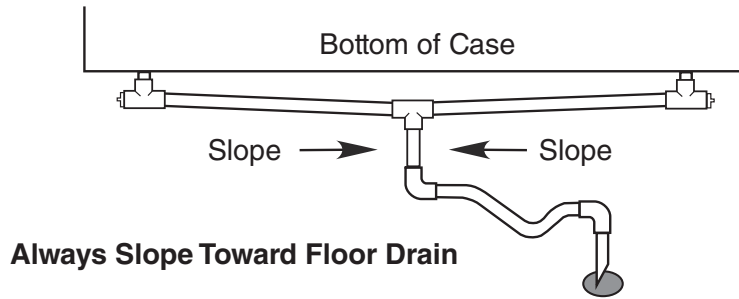

Optional Excel Drip Piping Arrangements (without Condensate Pump)

INSTALLING FACADES

Refer to the Hinge Location illustration to determine where hinges will be positioned on the top of the merchandiser.

Notice that hinge position will vary with the number of doors of the merchandiser.

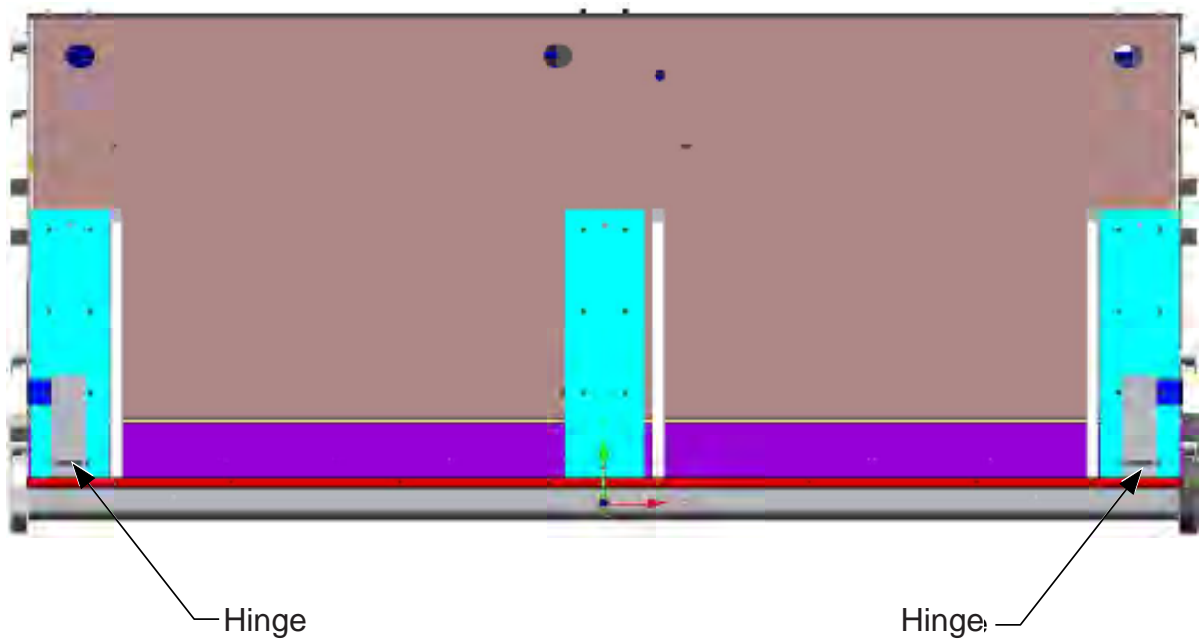
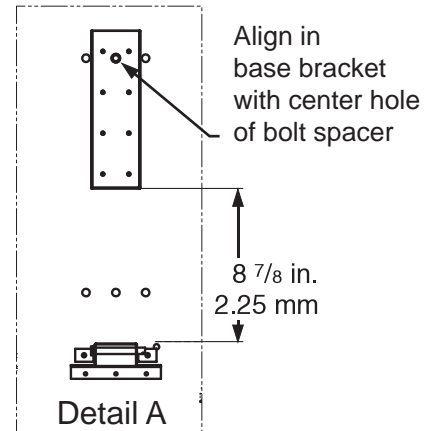

Facade Hinge Locations

Identify the corresponding positions on the facade panel, then fasten the hinges to the facade panel with provided screws.

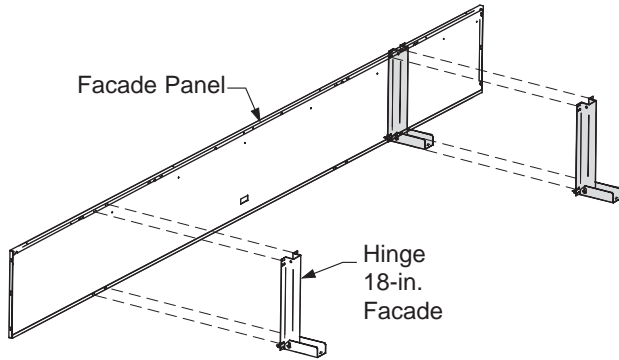

Fasten Hinges to Facade

Raise the elevator bolts at the bottom of the facade. Attach reinforcement straps to the Facade Panel with provided screws.

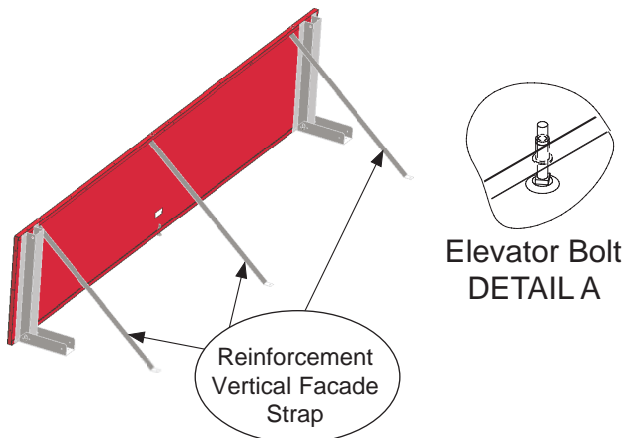

Fasten Reinforcement Strap

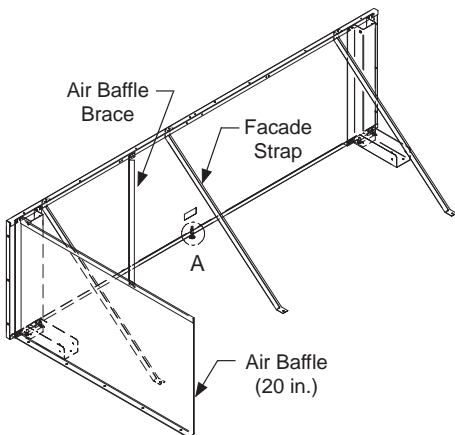

Install Air Baffle

Position the facade centered on case length and recessed from the fascia as shown in the side view. One hinge will be between the condensing unit and the electrical box. If necessary, the electrical box can be relocated.

Line up trim channel edge with edge of facade panel

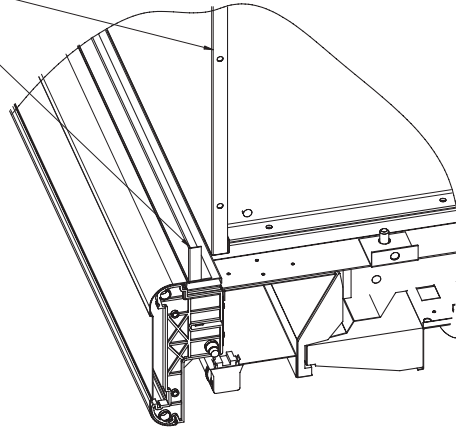

Attach facade channel to top of canopy fascia using #8 x 1/2 sheet metal screws provided. Place front of trim channel at edge of flat surface on canopy fascia top.

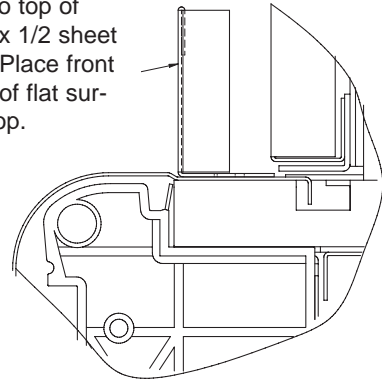

Fasten the hinge.
Fasten the reinforcement straps after hinges are attached using provided screws.

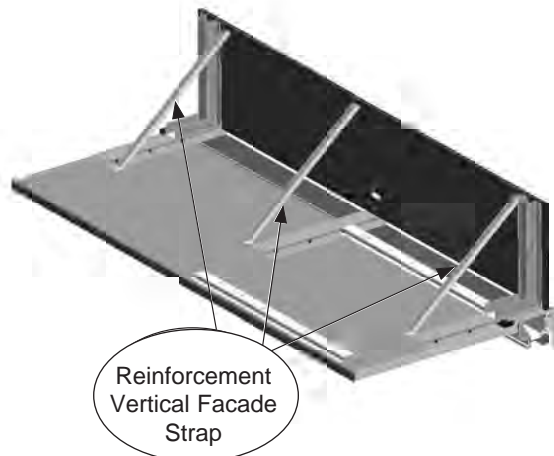

INSTALLING REAR CLOSE-OFFS

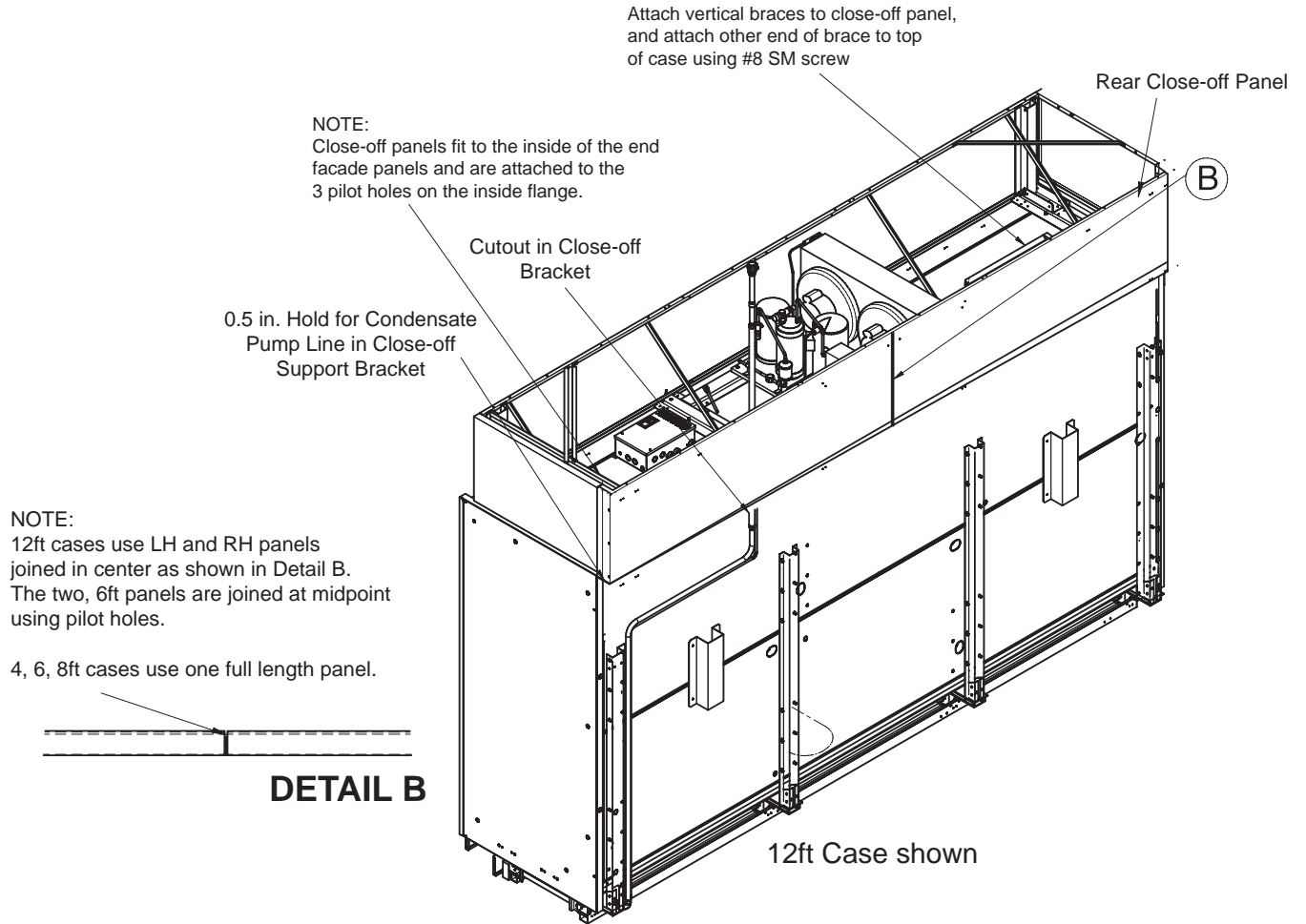

NOTE:
 12ft cases use LH and RH panels joined in center as shown in Detail B.
 The two, 6ft panels are joined at midpoint using pilot holes.
 4, 6, 8ft cases use one full length panel.

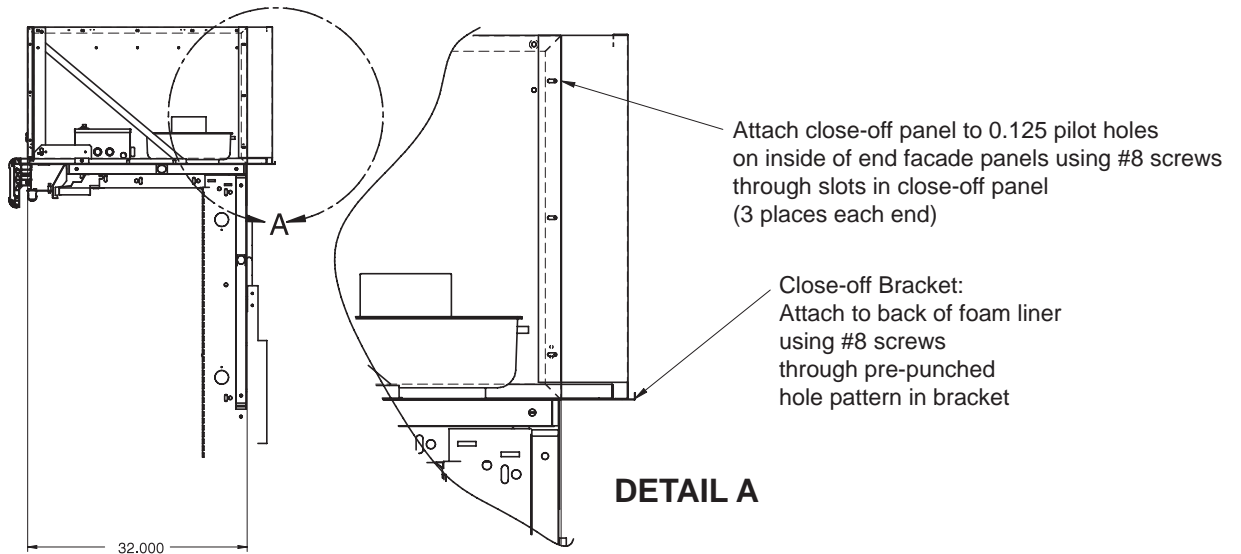
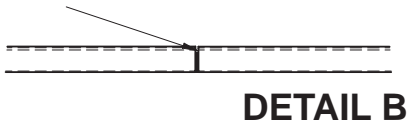

INSTALLING SPLASHGUARDS

The splashguard is shipped inside each merchandiser. **AFTER** merchandisers have been leveled and joined, and all drip piping, electrical and refrigeration work has been completed, install the splashguard.

To Install Splashguards:

1. Check to be sure that all splashguard brackets are level with the floor.
2. Position top of splashguard with the top angled in as shown in the illustration. Align the slots in the upper edge of the splashguard with the tabs extending downward behind the splashguard cover.
3. Engage the slots over the tabs and raise the splashguard while pushing the bottom in.
4. Align the tabs on the splashguard brackets with the slots in the bottom edge of the splashguard. Engage the tabs in the slots and drop the splashguard into place.

To install the cove trim to the splashguard:

1. Remove all dirt, wax and grease from the area of the splashguard where adhesion will be necessary to ensure a secure installation.
2. Apply a good contact cement to the cove trim and allow proper drying time according to the directions supplied with the cement.
3. Install the trim to the splashguard so that it is lying flush with the floor. **DO NOT SEAL THE TRIM TO THE FLOOR.**
4. **If required by local health codes** the Cove Trim may be sealed to the floor, using a silicone type sealer. Sealant must be removed and replaced when servicing.

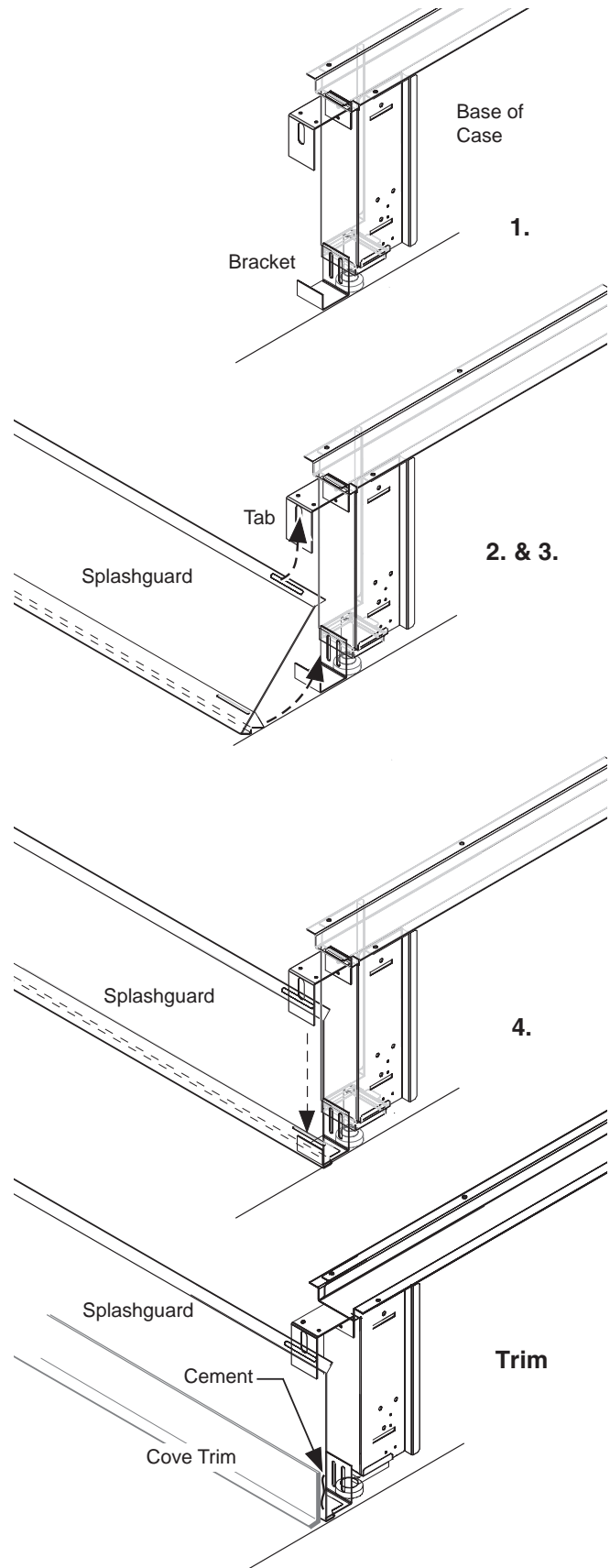

INSTALLING BUMPERS

Offsetting the bumpers and top rails helps to disguise the joint locations, giving the lineup a smoother look.

Begin at the left end of the line-up. A starter bumper is factory-installed with end kits. Insert the internal joint trim, then add the full-length bumper.

Align each bumper section with its retainer and push into place, working from the end of the lineup. Install full length bumpers and internal joint trims offset across joints. Make sure that no gaps exist between sections. Continue installing bumpers the length of the line up.

Do NOT install the last bumper sections at this time. These sections will be installed in the last step.

Once all except the last section of bumper have been installed, refrigerate the case line-up for at least six (6) hours. The last sections of bumper should be kept inside a refrigerated case or cooler during this time to allow the bumpers to contract.

Before installing the last full-length section, measure the remaining space. Use a miter box and fine-tooth saw to cut last bumper to length. Install the last section.

Remove protective film from bumpers once installation is complete.

Optional end bumpers are factory-installed.

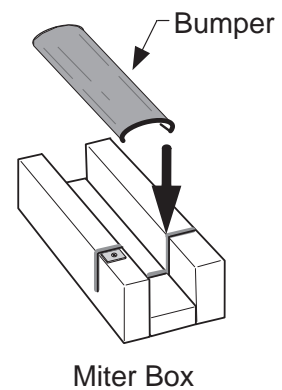
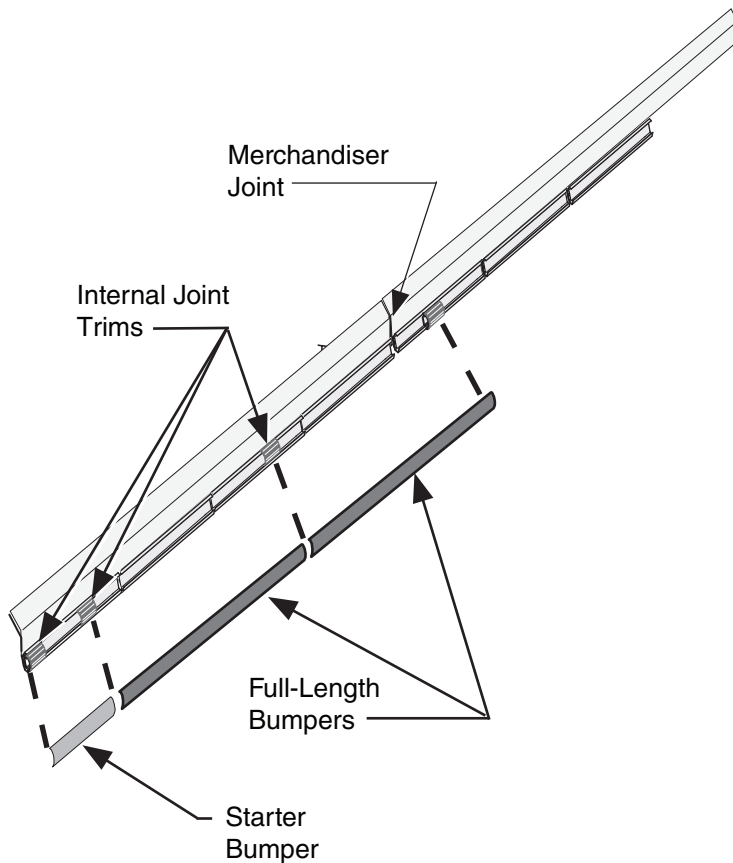

3-8

DRIP PIPING / FACADES / SPLASHGUARDS / BUMPERS

NOTES:

START-UP / OPERATION

CAUTION

Do NOT OPERATE REFRIGERATION SYSTEM OUTSIDE TYPE I AND TYPE II AMBIENT OPERATING CONDITIONS.

POOR PERFORMANCE OF REFRIGERATION SYSTEM MAY RESULT FROM CONTINUOUS OPERATION OUTSIDE OF THE FOLLOWING CONDITIONS:

ANSI/NSF-7 Type I – Display Refrigerator / Freezer
Intended for **75°F / 55%RH** Ambient Application

ANSI/NSF-7 Type II – Display Refrigerator / Freezer
Intended for **80°F / 55%RH** Ambient Application

EVAPORATOR PANS MAY OVERFLOW, CAUSING FLOODING DURING CONTINUOUS OPERATION IN EXTREME STORE TEMPERATURES.

After system startup and after 24 hours of operation make sure to verify that the oil level in the compressor is at 1/2 site glass on the compressor. Add compressor manufacturer's recommended type oil as needed to maintain correct level.

If refrigeration system operation is required for functional verification, please follow the recommendations below:

- » Install display case shelves before operation.
- » Drafts from open doors, fans, or other sources must be avoided.
- » Air discharge and return flues must remain open and free of obstruction at all times.
- » Temporarily set the refrigeration control knob to the warmest position for operation during non-controlled ambient conditions, to keep defrost water build-up to a minimum.
- » If heater pans have been de-energized following a defrost cycle, standing water will remain in the pans. Re-energize power to the pans long enough to remove remaining water before restarting refrigeration during non-controlled ambient conditions.

WARNING

Do not walk on top of case.
Do not store items or flammable materials atop the case.

CAUTION

Tipping Hazard

Case tipping may occur if cases are not properly leveled and secured, or if cases are not properly loaded.

START UP

See the merchandiser's Technical Data Sheet for refrigerant settings and defrost requirements. Bring merchandisers down to the operating temperatures listed on the data sheet. Each four foot section has its own evaporator coil and pre-set non-adjustable thermostatic expansion valve (TEV). No adjustment is required.

DO NOT REMOVE THE CAP ON THE TEVs. This cap is to be removed only for valve disassembly. Removal of this cap during merchandiser maintenance will result in refrigerant loss unless the system is first isolated and the refrigerant recovered.



CAUTION

REMOVAL OF THE TEV CAP WILL RESULT IN REFRIGERANT LOSS UNLESS THE SYSTEM IS FIRST ISOLATED AND THE REFRIGERANT RECOVERED.

The TEV has been factory set to provide the recommended performance settings as specified on the merchandiser data sheets.

STOCKING

Product should **NOT** be placed in merchandisers until merchandiser is at proper operating temperature.

Proper rotation of product during stocking is necessary to prevent product loss. Always bring the oldest product to the front and set the newest to the back.

AIR DISCHARGE AND RETURN FLUES MUST REMAIN OPEN AND FREE OF OBSTRUCTION AT ALL TIMES to provide proper refrigeration and air curtain performance. Do not allow product, packages, signs, etc. to block these grilles. Do not use non-approved shelving, baskets, display racks, or any accessory that could hamper air curtain performance.

LOAD LIMITS

Do not stock shelves above load limit decals. Shelf life of perishables will be short if load limit is violated. **AT NO TIME SHOULD THE MERCHANDISERS BE STOCKED BEYOND THE LOAD LIMITS INDICATED.**

DO NOT BLOCK HONEYCOMB OR RETURN AIR GRILLE.

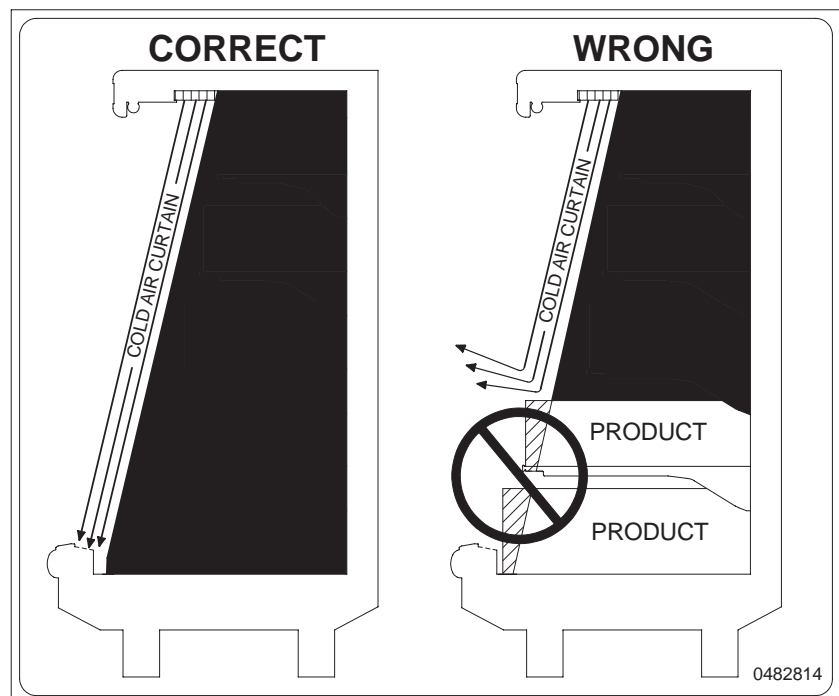

INSTALL SHELVES

Begin with the lowest row of shelves. Verify the shelf brackets are at 90 degrees to shelf. Keep shelf level from side to side while tilting the front down to insert the lowest tab in the shelf upright. Use a level on each shelf, or count slots in each upright and mark with tape to ensure rows of shelves stay level. Tabs must be seated firmly into position in the uprights before loading shelves.

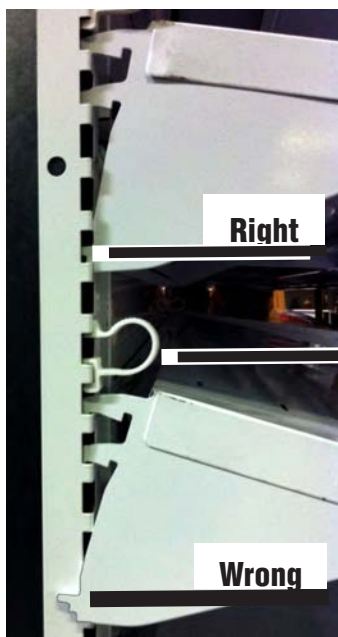

Right

Remove Shipping Clips



Wrong



Even Vertical Spacing in Upright



Uneven Vertical Spacing in Upright



MULTI-DECK SHELF CONFIGURATION

The bottom display shelves can be adjusted to accommodate shallow or volume displays (bulky items such as hams or chickens). The upper shelves are individually mounted in 1 in. (25 mm) increments and have two-, three-, or four-position brackets permitting shelves to be placed in a flat or down-tilt position (see illustration). Front product stops are recommended when shelves are placed in the down-tilt position.

Merchandiser performance will be degraded if peg shelves are used without baffles. Unauthorized specialty shelving may cause poor merchandiser performance also. Consult your Hussmann representative to ensure optimum performance of all Hussmann equipment.

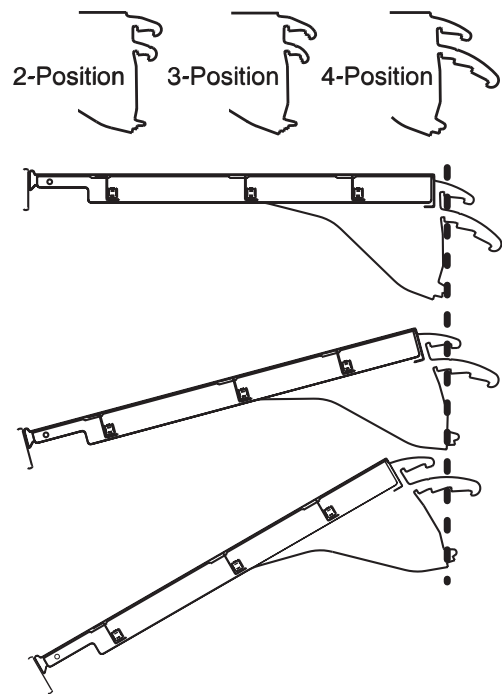

SHELF MAXIMUM WEIGHT LIMITS

Hussmann merchandiser shelves are designed to support the maximum weight load limits as indicated in the table below.

Weight Limits for Merchandiser Shelving

Nominal Shelf Depth	Maximum Load Limit
12 in. (305 mm)	125 lb (56.7 kg)
14 in. (357 mm)	125 lb (56.7 kg)
16 in. (406 mm)	200 lb (90.7 kg)
18 in. (457 mm)	200 lb (90.7 kg)
20 in. (508 mm)	250 lb (113.4 kg)
22 in. (559 mm)	250 lb (113.4 kg)
24 in. (610 mm)	250 lb (113.4 kg)
Heavy Duty Beverage Shelf 16 in. (406 mm)	300 lb (136 kg)
Heavy Duty Beverage Shelf 18 in. (457 mm)	320 lb (145.1 kg)
Heavy Duty Beverage Shelf 20 in. (508 mm)	350 lb (158.8 kg)
Heavy Duty Beverage Shelf 22 in. (559 mm)	350 lb (158.8 kg)
Heavy Duty Beverage Shelf 24 in. (610 mm)	350 lb (158.8 kg)

*Shelf load limits at 0° tilt

Merchandiser Shelf Depths	Recommended	Maximum
Narrow (37 in.) Merchandiser Depths	16 in. (406 mm)	18 in. (457 mm)
Standard (42 in.) Merchandiser Depths	22 in. (559 mm)	24 in. (610 mm)

Exceeding these maximum weight load limits may cause damage to the shelf or shelves, damage to the merchandiser, damage to store products, and potentially create a hazardous condition for customers and staff. Exceeding the indicated maximum weight load limits constitutes misuse as described in the Hussmann Limited Warranty.

1. Insert one of the alignment strips into the slot behind the front edge of each shelf.
2. After all shelves are installed, slide the strip across the shelf joint wherever two shelves are adjacent. This will lock them together.

OPTIONAL MULTI-DECK SHELF ALIGNMENT STRIPS

Taped to one of the shelves of each merchandiser is a small plastic bag containing optional shelf alignment strips. These strips are designed to enhance the appearance of the shelves by aligning the front edge of each shelf with that of an adjacent shelf.

When installing shelves:

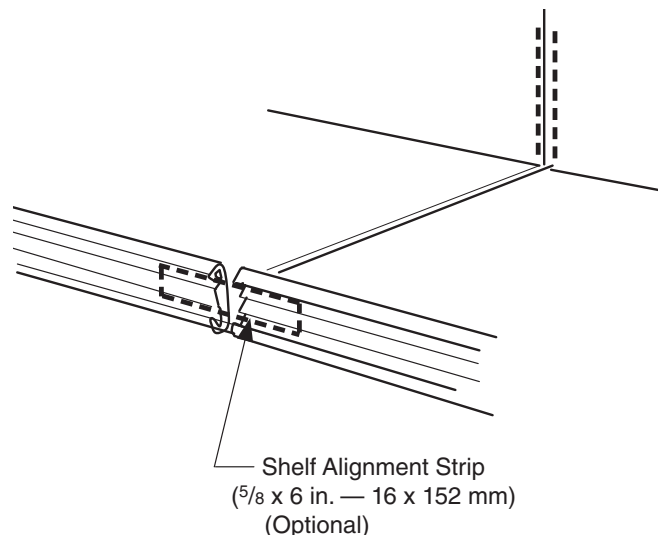

INSTALLING SHELF LIGHTING

Follow these instructions to ensure good contact between male and female connectors.



Shelf Light Plug



Shelf Light Receptacle

1. Remove produce from shelf and place in cooler. **SHUT OFF POWER TO THE MERCHANDISER.**

⚠ WARNING

— LOCK OUT / TAG OUT —

To avoid serious injury or death from electrical shock, always disconnect the electrical power at the main disconnect when servicing or replacing any electrical component. This includes, but is not limited to, such items as doors, lights, fans, heaters, and thermostats.

2. Turn off Canopy Light Switch. Remove all packed shelves.

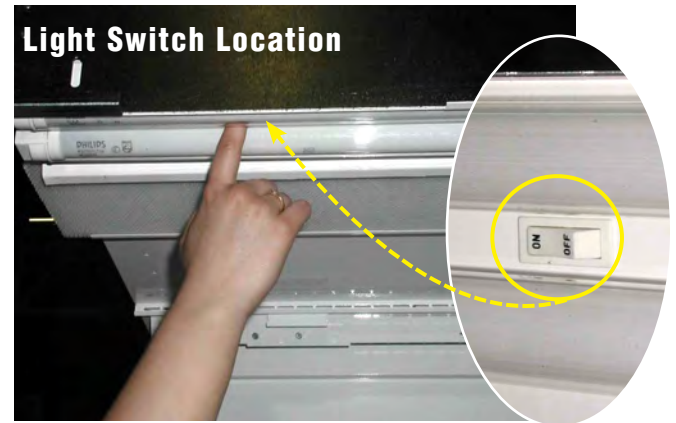

3. Remove shelf connectors from power sockets. Always grip shelf connector by the handle when removing from socket. **PULL handle DOWN AND THEN OUT to disengage.** Note that latch tongue must depress to disengage plug.

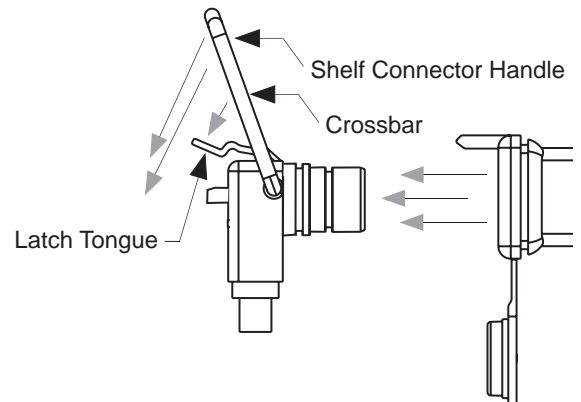

4. **Engage each power socket cap and ensure that each cap is fully seated before cleaning.** Ensure the proper seating of the cap at all times when the plug is not engaged.

- 5. Clean the merchandiser as described in the *Care and Cleaning* paragraphs of *Section 5 – Maintenance*. **Keep liquid out of sockets.** (Allow merchandiser shelves to dry before turning on shelf power.)
- 6. Verify that power is at the merchandiser and turned on. Verify that the merchandiser light switch is turned “OFF.” Switch is located in the canopy, on the left, behind first row of lamps.
- 7. See the illustration below. It is typical of D5X, C5X, and D6X models. Note that other models will have fewer rows of shelves. Starting from the left-hand bottom section, choose the location for the first shelf, X-1.

Secure the shelf in the slotted upright. Make certain that the shelf is level and that ends are in the same slot on the left and right upright. ***It is important that shelf brackets be properly seated in the slotted upright.***

- 8. Working from left to right, install the next shelf, X-2, to the right of the first shelf you installed. Always work from left to right and from the bottom up in each 8 ft (2438 mm) and 12 ft (3685 mm) merchandiser.
- 9. After each shelf on the bottom row is in position, be sure to remove the cap and insert the shelf connector. Push firmly.
- 10. Turn “ON” the merchandiser light switch after the entire bottom row has been installed in either 8 or 12 ft (2438 or 3658 mm) merchandisers. The shelf lights should light.

- If a shelf LED lights do not operate,
- A. Turn off light switch.
 - B. Remove and firmly re-insert each shelf plug.
 - C. Turn on light switch.

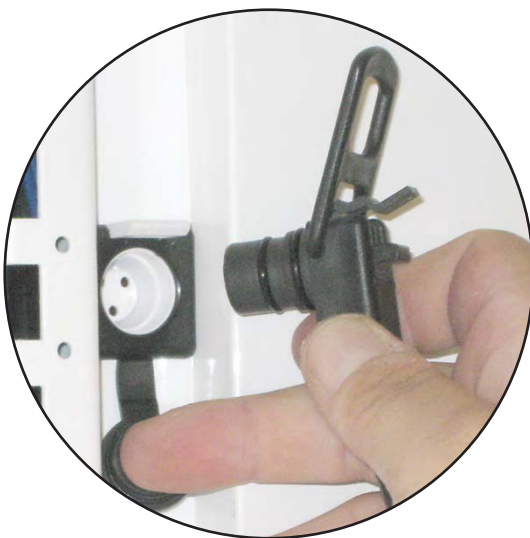
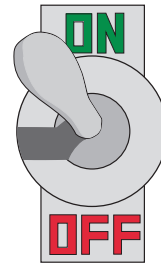

Shelf Socket

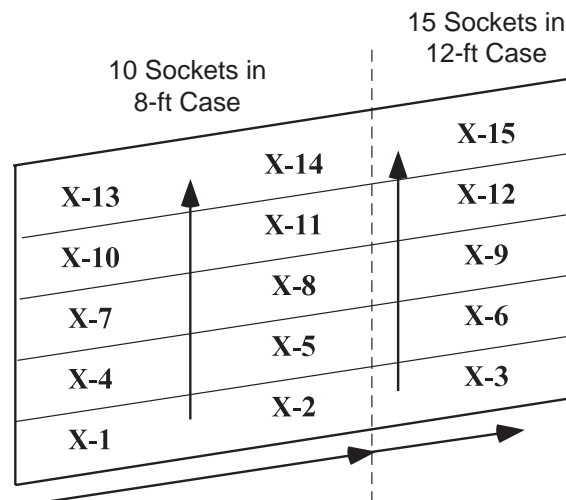

**Always work Left to Right,
and Bottom to Top**

Note: LED lamps use a 24VDC power supply.

If a shelf fluorescent light does not operate:

- A. Turn off light switch.
- B. Make certain the shelf lamps are properly engaged in the shelf lamp holders.
- C. Remove and firmly re-insert each shelf plug.
- D. Turn on light switch.

11. Using the row of shelves just installed as support, set the next shelf, X-4, in the desired location. Remove the cap and insert the shelf plug. Continue working left to right installing shelves X-5 and X-6.

Note: Since the location for the remaining shelves, X-4 to X-15, may be directly over the rear wall receptacle, the shelf should be plugged in before engaging brackets in the uprights. The lower shelf will support the weight of the next shelf until it is plugged in. After installing each shelf, verify that its plug is properly connected to its rear wall receptacle. Continue working row by row, bottom up, left to right.

INSTALLING FDA/NSF REQUIRED THERMOMETER

The following pages provide the same information that ships with the thermometer.

This requirement does not apply to display refrigerators intended for bulk produce (refer to page 1-1).

Please note that the tape cannot be exposed after installation.

This is an NSF-7 & US FDA Food Code Required Thermometer

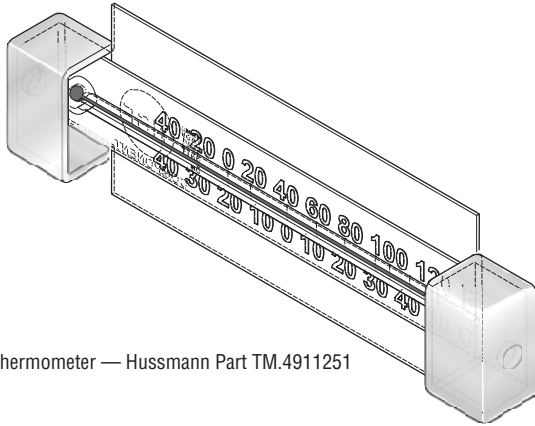

Thermometer — Hussmann Part TM.4911251

Hussmann Corporation • 12999 St. Charles Rock Road • Bridgeton, MO 63044-2483
 U.S. & Canada 1-800-922-1919 • Mexico 1-800-890-2900 • www.hussmann.com
 © 2007 Hussmann Corporation

Suggested Mounting Locations in Single Deck Glass Front Impact Merchandisers

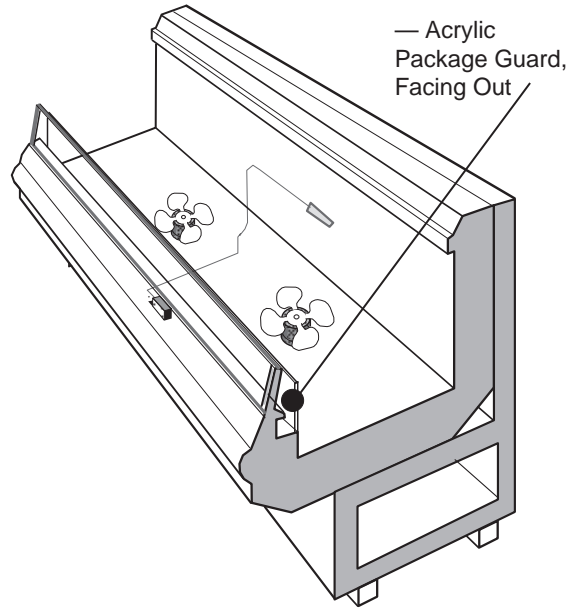

— Acrylic Package Guard, Facing Out

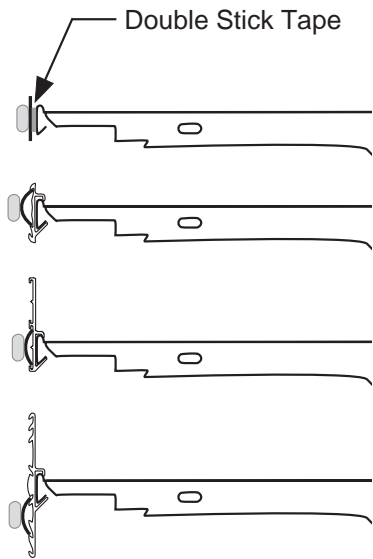

Double Stick Tape

Flexible Plastic Fits in Price Tag Moldings

Hussmann P/N 0429971_C

10/2007

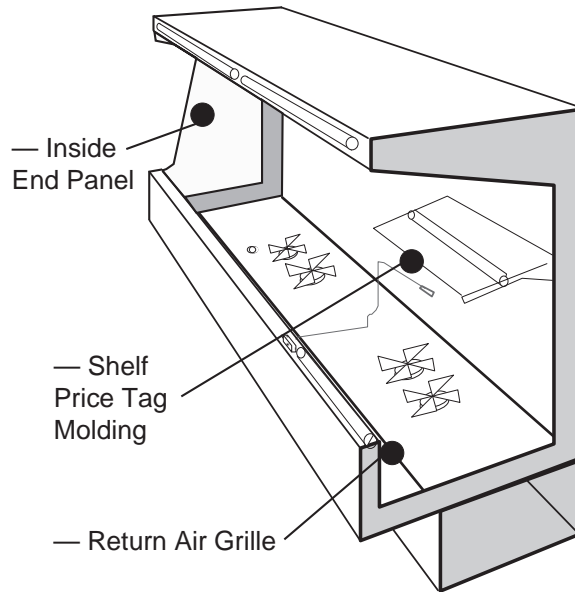

— Inside End Panel

— Shelf Price Tag Molding

— Return Air Grille

Suggested Mounting Locations in Multi-deck Merchandisers

Important – Please read!

This thermometer is provided in response to United States
Food and Drug Administration (US FDA) Food Code [<http://www.fda.gov/>]
and
National Sanitation Foundation (NSF / ANSI) Standard 7 [<http://www.nsf.org/>]

Each installation will be different depending on how the unit is stocked, shopping patterns in the department and ambient conditions of the store. The suggested locations provided herein are possible locations. It is the responsibility of the purchaser / user to determine the location with the food storage area of the unit that best meets the code requirements above.

The thermometer may need to be moved several times to find the warmest location. Mounting options include flexible plastic for price tag molding application, magnet applied to back of flexible plastic for steel end wall, and double stick tape. Tape must not be exposed after installation.

Questions about either code should be addressed to local agencies or other appropriate officials.

**Keep with merchandiser
or give to store manager.**

DO NOT DESTROY.

NOTES:

MAINTENANCE

CARE AND CLEANING

Long life and satisfactory performance of any equipment is dependent upon the care it receives. To ensure long life, proper sanitation and minimum maintenance costs, these merchandisers should be thoroughly cleaned, all debris removed and the interiors washed down, weekly.

Fan Plenum

To facilitate cleaning, the fan plenum is hinged. After cleaning be sure the plenum is properly lowered into position OR PRODUCT LOSS WILL RESULT due to improper refrigeration.





WARNING

SHUT FANS OFF DURING CLEANING PROCESS.

Removable Return Air Grille

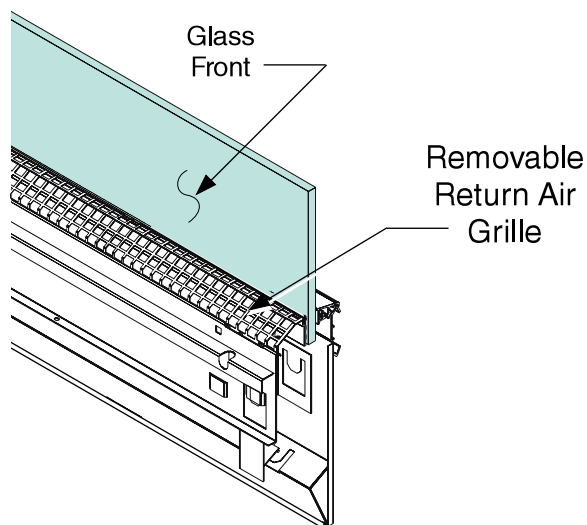
The return air grille may be removed to facilitate cleaning. Simply lift a four foot section up and out as shown below.





WARNING

Do not use HOT water on COLD glass surfaces. This can cause the glass to shatter and could result in personal injury. Allow glass fronts, ends and service doors to warm before applying hot water.

Fascia Panels

The fascia panels lift out, left to right, and should be cleaned with a mild detergent and warm water.

DO NOT USE AMMONIA-BASED PRODUCTS TO CLEAN OPTIONAL ACRYLIC PANELS. NEVER USE ABRASIVE CLEANSERS OR SCOURING PADS.



Exterior Surfaces

The exterior surfaces must be cleaned with a mild detergent and warm water to protect and maintain their attractive finish. **NEVER USE ABRASIVE CLEANSERS OR SCOURING PADS.**

Interior Surfaces

The interior surfaces may be cleaned with most domestic detergents, ammonia based cleaners and sanitizing solutions with no harm to the surface. Always read and follow the manufacturer's instructions when using any cleaning product.



WARNING

Product will be degraded and may spoil if allowed to sit in a non-refrigerated area.



WARNING

Do NOT allow cleaning agent or cloth to contact food product.

Do NOT Use:

- Abrasive cleansers and scouring pads, as these will mar the finish.
- Coarse paper towels on coated glass.
- Ammonia-based cleaners on acrylic parts.
- A hose on lighted shelves or submerge the shelves in water.
- Solvent, oil or acidic based cleaners on any interior surfaces.
- A hose on rail lights, canopy lights or any other electrical connection.

Do:

- Remove the product and all loose debris to avoid clogging the waste outlet.
- Engage shelf light caps if removing shelves.
- Store product in a refrigerated area such as a cooler. Remove only as much product as can be taken to the cooler in a timely manner.
- **First turn off refrigeration, then disconnect electrical power.**
- Thoroughly clean all surfaces with soap and hot water. **DO NOT USE STEAM OR HIGH WATER PRESSURE HOSES TO WASH THE INTERIOR. THESE WILL DESTROY THE MERCHANDISERS' SEALING CAUSING LEAKS AND POOR PERFORMANCE.**
- Lift hinged fan plenum for cleaning. Hook chain in rear panel to secure plenum during cleaning.
BE SURE TO REPOSITION THE FAN PLENUM AFTER CLEANING MERCHANDISER.
- Take care to minimize direct contact between fan motors and cleaning or rinse water.
- Rinse with hot water, but do NOT flood. **NEVER INTRODUCE WATER FASTER THAN THE WASTE OUTLET CAN REMOVE IT.**
- Allow merchandisers to dry before resuming operation.

- Wipe down lighted shelves with a damp sponge or cloth so that water does not enter the light channel. **DO NOT USE A HOSE OR SUBMERGE SHELVES IN WATER.**
- After cleaning is completed, turn on power to the merchandiser.
- Ensure shelf lights are fully seated and engaged.

CLEANING MIRRORS

Mirrors are sheets of clear glass that have very thin reflective and protective coatings applied to one side. These coatings are susceptible to deterioration if certain cleaning solutions and even water are allowed to come in contact with them. Every precaution should be taken to keep all liquids away from the coated side of the mirrors. **IF LIQUIDS ARE ALLOWED TO FLOW ALONG THE FACE SIDE OF THE MIRROR TO ITS EDGE, THE LIQUID CAN SEEP UP BETWEEN THE COATING AND THE GLASS, CAUSING SERIOUS DAMAGE.**

To Help Prolong the Life of the Mirrors:

- Use only mild cleaning solutions that do not leave residue, such as a weak (10%) solution of vinegar and water.
- Do NOT spray liquids on the mirrors. Away from food, dampen the cleaning cloth, then use the cloth to wipe the mirror.
- Wipe water from the mirrors immediately to prevent difficult to remove water spots and also to prevent the water from reaching the mirror's edge.
- Never use dirty cloths, scrapers or any other abrasive materials for cleaning.

CLEANING HONEYCOMB ASSEMBLIES

Honeycombs should be cleaned every six months. Dirty honeycombs will cause merchandisers to perform poorly. The honeycombs may be cleaned with a vacuum cleaner. Soap and water may be used if all water is removed from the honeycomb cells before replacing. Be careful not to damage the honeycombs.

Multi-deck Merchandisers

1. Loosen or remove screw to free honeycomb.
2. Clean and dry the honeycomb.
3. After cleaning, replace honeycomb and slide retainer forward. Reinstall screw.

Damaged honeycomb must be replaced.

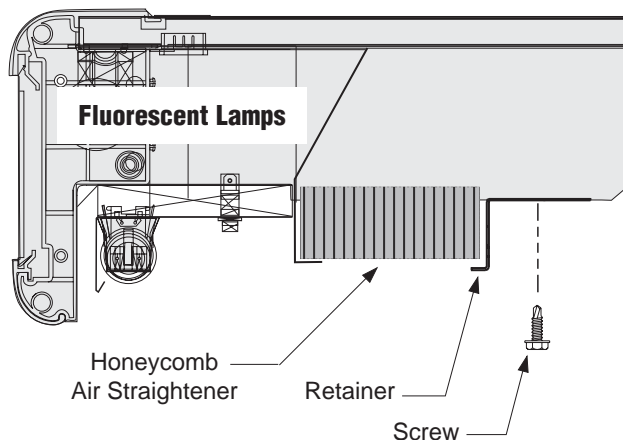
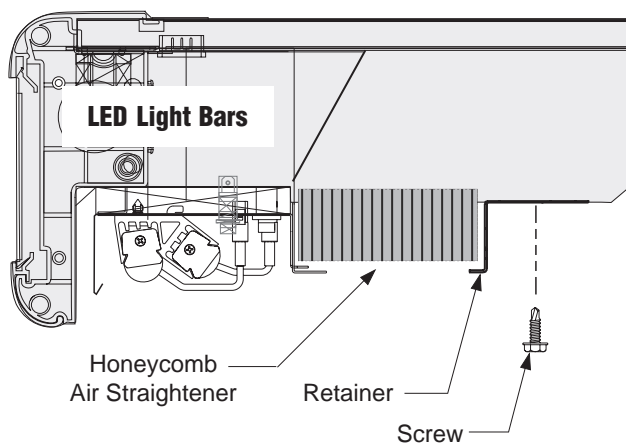

CLEANING STAINLESS STEEL RAILS

Use non-abrasive cleaning materials, and always polish with grain of the steel. Use warm water or add a mild detergent to the water and apply with a cloth. Always wipe rails dry after wetting.

Use alkaline chlorinated or non-chlorine containing cleaners such as window cleaners and mild detergents. Do not use cleaners containing salts as this may cause pitting and rusting of the stainless steel finish. Do not use bleach.

Clean frequently to avoid build-up of hard, stubborn stains. A stainless steel cleaning solution may be used periodically to minimize scratching and remove stains.

Rinse and wipe dry immediately after cleaning. Never use hydrochloric acid (muriatic acid) on stainless steel.

REMOVING INTERIOR BACK PANELS

The interior back panels may be removed for cleaning and to gain access to the evaporator coils. Remove the rear interior back panels as follows:

1. **DISCONNECT THE ELECTRICAL POWER TO THE MERCHANDISER.**
2. Unplug shelf lights and insert plastic protective cap. Remove shelving.
3. Remove the lower panel first: lift the panel up, then pull forward and out.
4. Remove the top panel.
5. Replace panels in reverse order, starting with the top panel.
6. After cleaning or servicing the merchandiser, allow shelf lights to fully dry. Reconnect shelf lights and return power to the merchandiser.

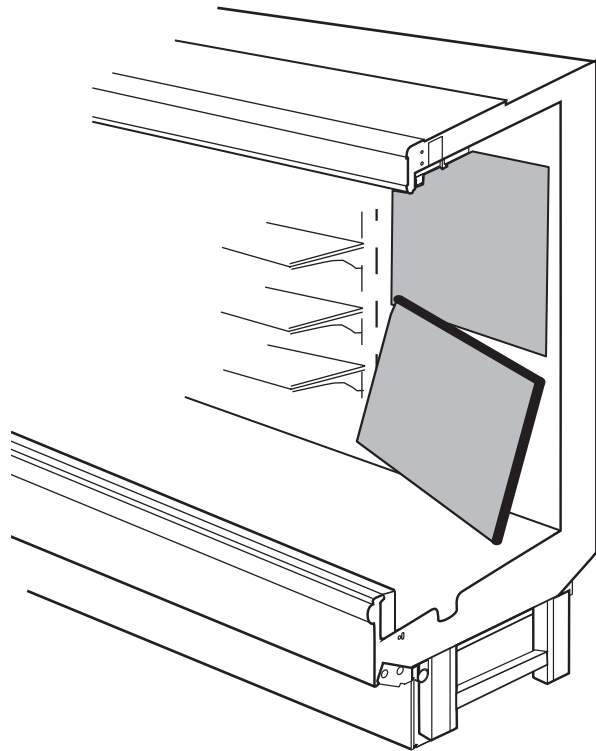

CLEANING COILS

NEVER USE SHARP OBJECTS AROUND COILS. Use a soft brush or vacuum brush to clean debris from coils. *Do not puncture coils!* Do not bend fins. Contact an authorized service technician if a coil is punctured, cracked, or otherwise damaged.

ICE in or on the coil indicates the refrigeration and defrost cycle is not operating properly. Contact an authorized service technician to determine the cause of icing, and to make adjustments as necessary. To maintain product integrity, move all product to a cooler until the unit has returned to normal operating temperatures.

CLEANING CONDENSATE PUMP AND HEATED EVAPORATION PANS

ALWAYS DISCONNECT POWER AT THE MAIN CASE DISCONNECT BEFORE SERVICING THE EQUIPMENT.

- The condensate water outlet for the self-contained models empties into a limited capacity evaporation pan.
- Clean product spills immediately. If a product spill enters the Condensate Pump or Heated Evaporation Pans, a maintenance technician may be required to clean both the pump and heated pans.
- Clean case interior with a sponge or soft cloth, wetted with mild soap and water. Do not pour water from a bucket or hose into case drain. Water introduced during cleaning will cause the evaporation pan to overflow.
- Sediment and debris will clog the Condensate Pump and plastic tubing for water delivery to the Heated Evaporation Pans.
- The Condensate Pump and the Heated Evaporation Pans require regular monthly inspection. The Condensate Pump is located below the case bottom. The Heated Evaporation Pans are located on the case top. Evidence of excess water or odor is an indication that immediate service is required.
- Recommended cleaning the Condensate Pump reservoir and Heated Evaporation Pans is with mild soap and water. Disconnect power before cleaning. Empty pump sump and heater pans of water before reapplying power.
- If using the optional Defrost Synchronization controls, the Master Sync Switch needs to be reset by the maintenance technician after re-applying electrical power to case.

WARNING

— LOCK OUT / TAG OUT —

To avoid serious injury or death from electrical shock, always disconnect the electrical power at the main disconnect when servicing or replacing any electrical component. This includes, but is not limited to, such items as doors, lights, fans, heaters, and thermostats.

WARNING

Evaporation Pan is Hot!
and poses risk of bodily injury
— Always wear gloves and protective eye wear when servicing condensate pump and heated evaporation pans. Turn off evaporation pan heater, and allow pan to cool before servicing.

CLEANING UNDER MERCHANDISERS

Remove splashguards not sealed to floor. Use a vacuum with a long wand attachment to remove accumulated dust and debris from under the merchandiser.

Excessive ambient conditions may cause condensation and therefore sweating of doors. Facility operators should monitor doors and floor conditions to ensure safety of persons.

REMOVING SCRATCHES FROM BUMPER

Most scratches and dings can be removed using the following procedure.

1. Use steel wool to smooth out the surface area of the bumper.
2. Clean area.
3. Apply vinyl or car wax and polish surface for a smooth glossy finish.

MAINTAINING FLUORESCENT LAMPS

Fluorescent lamps should not be allowed to run to failure. If a re-lamp schedule is not in place, the tubes should be inspected for signs of degradation (blackened ends). Degraded or failed tubes should be replaced.

Allowing severely degraded lamps to operate may cause a ballast failure or could expose the lamp holder to excessive heat. Replacing degraded bulbs is more cost effective than replacing ballast and lamp-holders.

Traditional re-lamp programs are 18- to 24-month intervals. In the absence of a re-lamp program, a yearly inspection of the lighting system is recommended.

1. Inspect all lamp sockets and plug-receptacle connections for signs of arcing. Replace any component that shows signs of arcing.
2. Make sure all unused receptacles have their close-off covers securely installed.
3. Make sure proper cleaning procedures are followed. Lights and fans **MUST** be turned off when a case is cleaned and **MUST** be allowed to dry before turning power back on.
4. Do not use a pressure nozzle to clean inside a case.

SERVICE

REPLACING FAN MOTORS AND BLADES

See cross section for location of evaporator fans. Should it ever be necessary to service or replace the fan motors or blades be certain that the fan blades are re-installed correctly.

For access to these fans:

1. Turn off power.
2. Remove bottom display pans.
3. **Disconnect fan from wiring harness.**
4. Remove fan blade.
5. Remove screws holding fan motor/bracket assembly to plenum and remove assembly.
6. Replace fan motor/bracket assembly and reinstall screws.
7. Reinstall fan blade.
8. Reconnect fan to wiring harness.
9. Turn on power.
10. Verify that motor is working and blade is turning in the correct direction.
11. Close air gaps under fan plenum. Warmer air moving into refrigerated air reduces effective cooling. If the plenum does not rest against the case bottom without gaps, apply foam tape to the bottom of the fan plenum to reduce improper air movement. Use silicone sealant to close other gaps.
12. Replace display pans. Bring merchandiser to operating temperature before restocking.

WARNING

— LOCK OUT / TAG OUT —

To avoid serious injury or death from electrical shock, always disconnect the electrical power at the main disconnect when servicing or replacing any electrical component. This includes, but is not limited to, such items as doors, lights, fans, heaters, and thermostats.

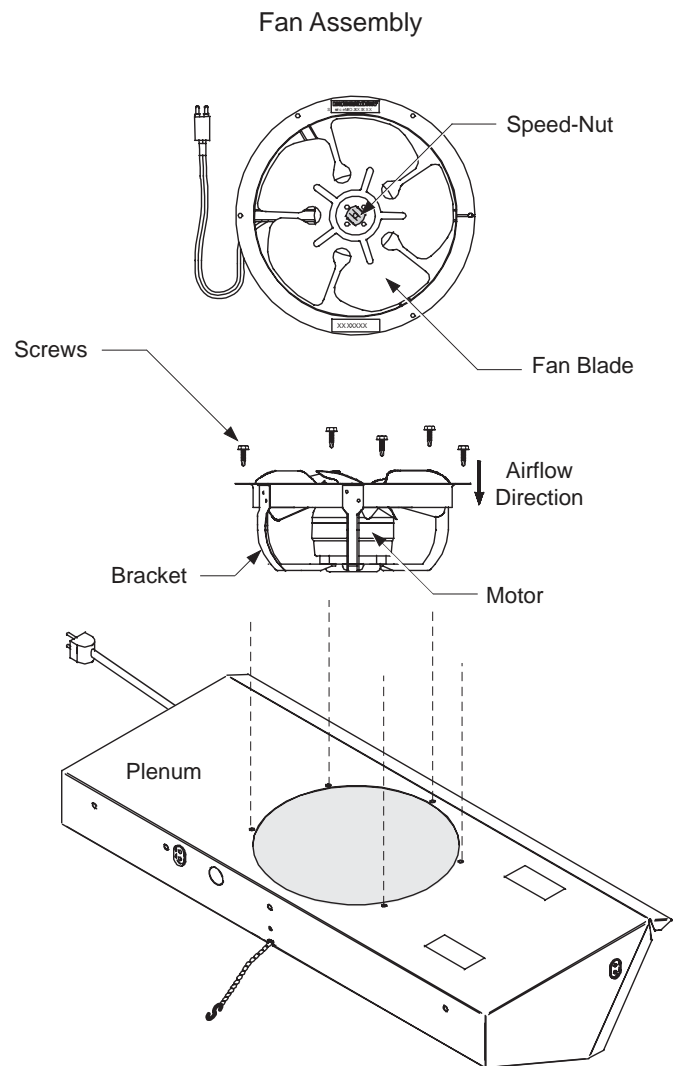

REPLACING LED CANOPY LIGHT BARS

Route electrical wiring connections for the single-row canopy. Connection can be made at the power supply using a molex connector, or use approved wire connectors or heat shrink butt connectors. Attach the Canopy LEDs to the canopy using mounting clips and screws.

NOTE:

One power supply can provide power for as many as 3 canopy lights.

LEDs (Top View)

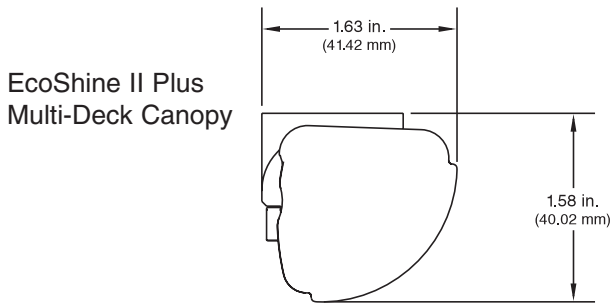
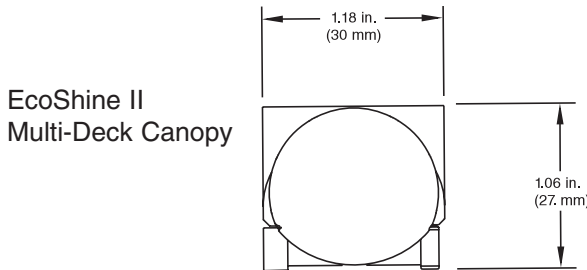
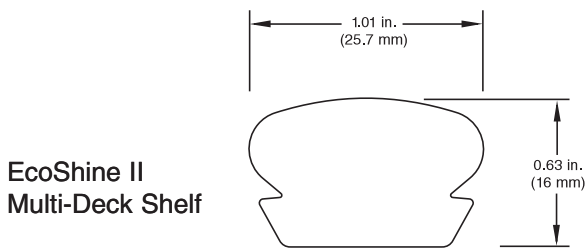

Light Bar Clips

The light bars are attached to the lamp panel using clips. Contact your Hussmann representative to replace light clips if the clips become damaged, or missing.

The light bars are connected through a two-conductor connector. Push on the release tab on the connector, then pull down on the connector. Do not pull on wires. LED power source is 24-volts for safety.

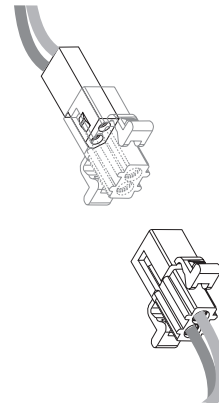

Canopy LED Light Connector

REPLACING LED SHELF LIGHT BARS

The LED shelf light bars are held in place with magnets on the back of the light bar.

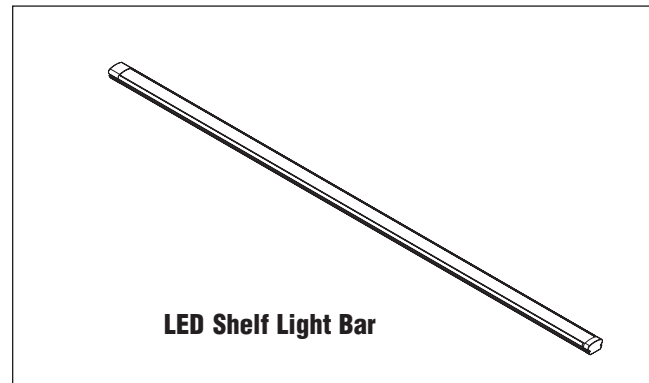

1. Turn off power to the merchandiser, and turn canopy light switch off. Unplug the shelf connector from its socket.

2. Replace with the appropriate Hussmann LED light bar.

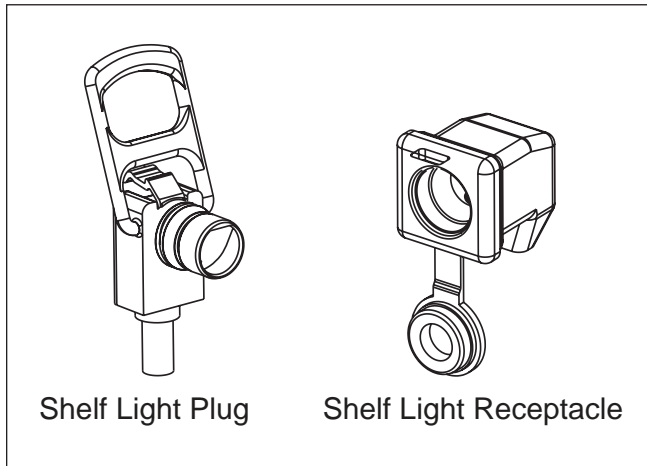

REPLACING LED POWER SUPPLIES

The LED power supplies for canopy lights and shelf lights are located at the top of the merchandiser inside the canopy.

1. **DISCONNECT POWER TO THE MERCHANDISER.**
2. Remove light bars from the canopy.
3. Remove the screws that secure the lamp panel.
4. Grasp the lamp panel at its front edge and carefully pull down. It will swing freely from its hinged rear edge.
5. Replace power supply and reassemble parts in reverse order.
6. Reconnect the electrical power.

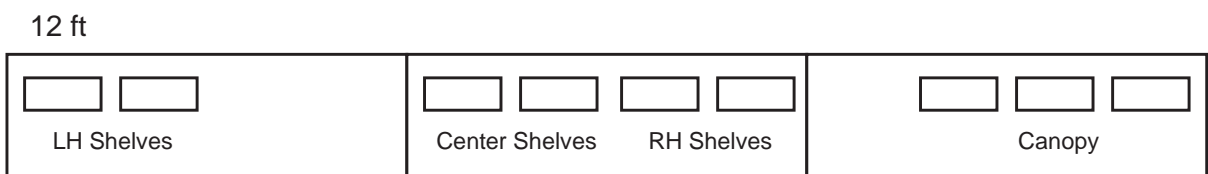
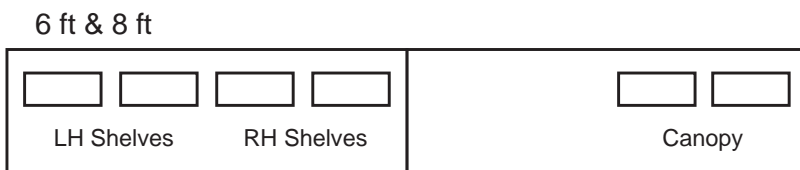
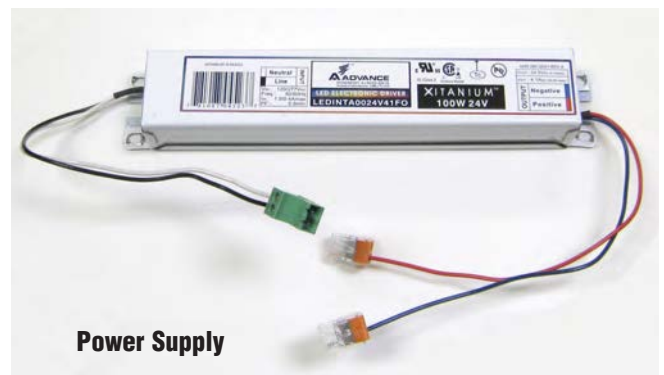

Canopy and Shelf LED Power Supply Arrangement

REPLACING FLUORESCENT LAMPS

Fluorescent lamps are furnished with moisture resistant lamp holders, shields and end caps. Whenever a fluorescent lamp is replaced, be certain to reinstall the lamp shields and end caps.

The switch in the canopy controls all lamps in the merchandiser.

Inspect all lamp sockets and plug–receptacle connections for signs of arcing. Replace any component that shows signs of arcing.

Make sure all unused receptacles have their close-off covers securely attached.

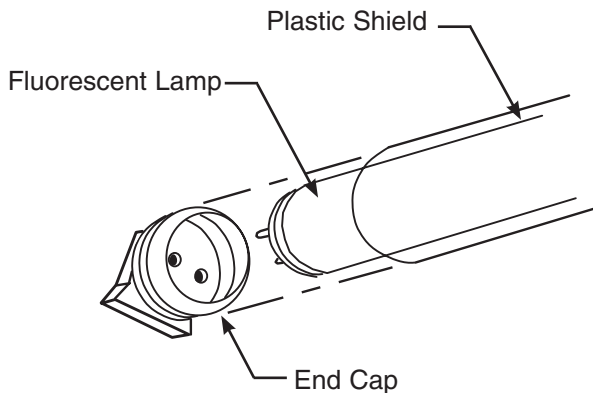

REPLACING LAMP HOLDERS AND END CAPS

The Impact Excel lamp holder is designed to snap into the sheet metal of the case. The lamp holder has a locking ‘nub’ which fits inside the groove of specially designed end caps.

IMPORTANT!

Always replace lamp holders and end caps with Hussmann lamp holders and end caps.

Use of non-Hussmann parts may result in poor electrical contact and short lamp life.

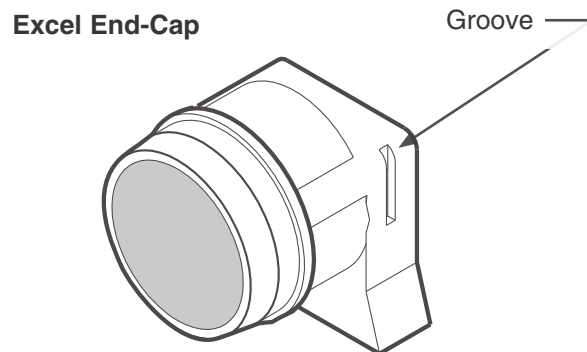
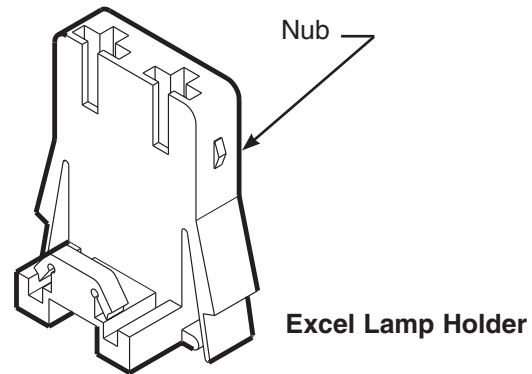

REPLACING ELECTRONIC BALLASTS

Rail Lamp Ballast

The rail lamp ballast is located in the raceway at the left-hand end of the merchandiser.

To gain access:

1. **DISCONNECT THE ELECTRICAL POWER TO THE MERCHANDISER.**
2. Remove screws attaching the raceway cover, then remove cover.
3. Service or replace ballast as required. Reassemble items as they were originally installed.
4. Reconnect the electrical power.

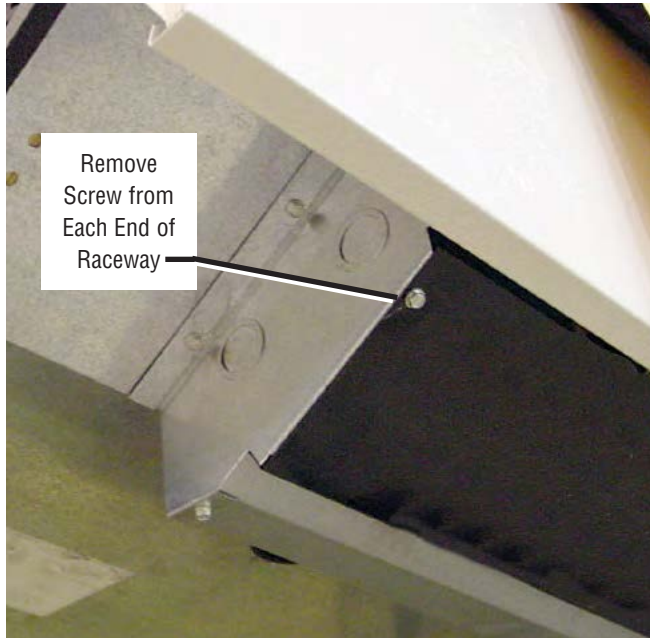

Raceway Access at Left Hand End

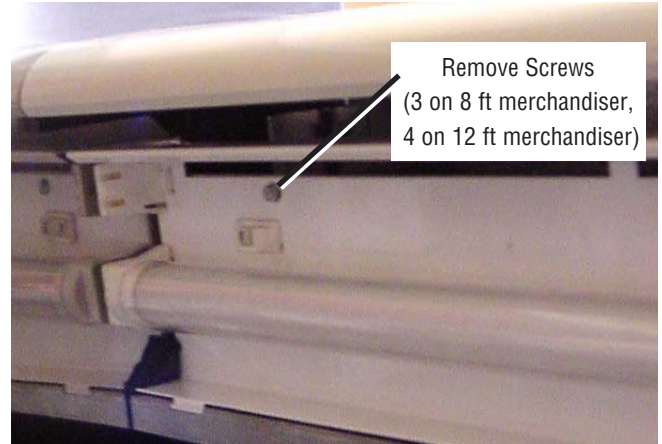

Remove Front Lamp Assembly to Access Screws

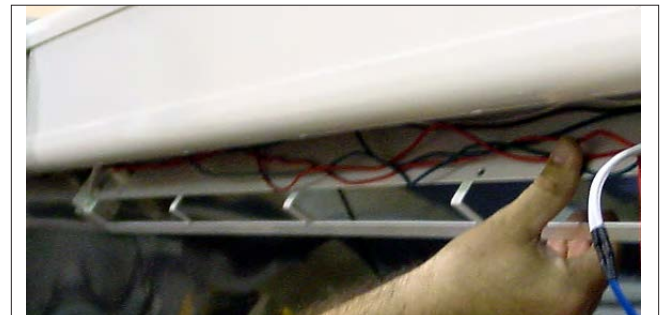

Access to Canopy and Shelf Ballasts

Canopy and Shelf Lamp Ballasts

These ballast are located at the top of the merchandiser inside the canopy.

1. **DISCONNECT POWER TO THE MERCHANDISER.**
2. Remove fluorescent lamps from the canopy.
3. Remove the screws that secure the lamp panel.
4. Grasp the lamp panel at its front edge and carefully pull down. It will swing freely from its hinged rear edge.
5. Replace ballast and reassemble parts in reverse order.
6. Reconnect the electrical power.

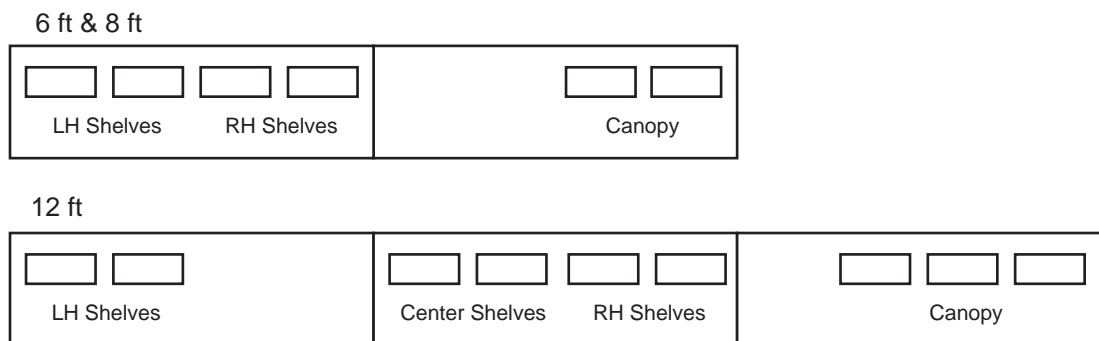

Canopy and Shelf Ballast Arrangement

Note: The ballasts used in Impact *Excel* models have built-in anti-arc protection. An electrical arc may occur if a shelf plug is not seated properly, or if a lamp is not properly seated in a lampholder. The ballast will shut down when it detects an arc. Two to four lamps will be out in the merchandiser when this occurs. Carefully check the plugs to make sure they are fully seated, and check the lamps to ensure they are firmly seated in the lamp-holders on the affected shelves. To reset a ballast that has ‘tripped’ on anti-arc, turn off the merchandiser light switch for a minimum of 15 seconds, then turn it on.

REPAIRING ALUMINUM COIL

The aluminum coils used in Hussmann merchandisers may be easily repaired in the field. Materials are available from local refrigeration wholesalers.

Hussmann recommends the following solders and technique:

Solders

Aladdin Welding Products Inc.
P.O. Box 7188
1300 Burton St.
Grand Rapids, MI 49507
Phone: 1-800-645-3413
Fax: 1-800-645-3414

X-Ergon
1570 E. Northgate
P.O. Box 2102
Irving, TX 75062
Phone: 1-800-527-9916

NOTE:

Hussmann Aluminum melts at 1125°F (607°C)
Aladdin 3-in-1 rod at 732°F (389°C)
X-Ergon Acid core at 455°F (235°C)

Technique:

1. Locate Leak.
2. REMOVE ALL PRESSURE.
3. Brush area UNDER HEAT.
4. Use PRESTOLITE TORCH ONLY.
Number 6 tip.
5. Maintain separate set of stainless steel brushes and USE ONLY ON ALUMINUM.
6. Tin surface around area.
7. Brush tinned surface UNDER HEAT, thoroughly filling the open pores around leak.
8. Repair leak. Let aluminum melt solder, NOT the torch.
9. Don't repair for looks. Go for thickness.
10. Perform a leak check.
11. Wash with water.
12. Cover with a good flexible sealant.

The Service Bulletin reprinted on the following pages are reprinted with permission from Emerson.

Electronic Unit Controller

TABLE OF CONTENTS

<u>Section</u>	<u>Page</u>	<u>Section</u>	<u>Page</u>
Safety		3. Alarm Menu	9
Safety Instructions.....	2	4. Service Menu	9
Safety Icon Explanation	2	5. Parameter List	10-11
Instructions Pertaining to Risk of Electrical Shock, Fire, or Injury to Persons	3	6. Controller Wiring	12
Safety Statements	3	6.1 Non-Fan Cycling Wiring Schematic	12
1. Introduction and Features	4	6.2 Fan Cycling Wiring Schematic	12
1.1 Technical Specifications	5	6.3 Copeland Performance Alert Connection	13
1.2 Pressure Probe Error Bypass	5	6.4 Additional Controller Inputs	13
1.3 Bump Start	5	7. Alarms and Notifications	14
2. Installation and Controller Operation		7.1 Discharge Line Temperature Protection	15
Instructions	5	7.2 UL High Pressure Safety Control	15
2.1 Condensing Unit Installation Instructions	5	8. Electronic Unit Controller Replacement	16
2.2 Controller Display	5	8.1 Silver Electrical Box Applications	16
2.3 Button Descriptions and Key Combinations	6	8.2 Small Black Electrical Box Applications	17
2.4 Viewing the Set Points	7	8.3 Plastic Retainer Applications	17
2.5 Changing a Parameter Value	7	8.4 Setting Controller Parameters After Replacement	18
2.6 Entering the Advanced Options Menu.....	7	8.5 Replacing -00 Controller with -01 or -02 Controller	18
2.6.1 Moving Parameters Between the Programming Menu and the Advanced Options Menu	7	9. Thermistor Temperature Resistance Values ..	19-20
2.6.2 Programming Using a Hotkey	8	10. Measuring Pressure Voltage Values	21
2.7 Locking the Keypad.....	9	11. Troubleshooting Guide	22-23
2.8 Unlocking the Keypad	9	12. Parts Kits	24
2.9 Resetting Alarm and Runtime Counters	9		



Safety Instructions

Copeland™ brand products are manufactured according to the latest U.S. and European Safety Standards. Particular emphasis has been placed on the user’s safety. Safety icons are explained below and safety instructions applicable to the products in this bulletin are grouped on Page 3. These instructions should be retained throughout the lifetime of the compressor. **You are strongly advised to follow these safety instructions.**

Safety Icon Explanation



DANGER indicates a hazardous situation which, if not avoided, will result in death or serious injury.



WARNING indicates a hazardous situation which, if not avoided, could result in death or serious injury.



CAUTION, used with the safety alert symbol, indicates a hazardous situation which, if not avoided, could result in minor or moderate injury.



NOTICE is used to address practices not related to personal injury.







CAUTION, without the safety alert symbol, is used to address practices not related to personal injury.

AE8-1376 R5

May 2016

Instructions Pertaining to Risk of Electrical Shock, Fire, or Injury to Persons

	<p>ELECTRICAL SHOCK HAZARD</p> <ul style="list-style-type: none"> • Disconnect and lock out power before servicing. • Allow drive components to electrically discharge for a minimum of two minutes before servicing. • Use compressor with grounded system only. • Molded electrical plug must be used in all applications. • Refer to original equipment wiring diagrams. • Electrical connections must be made by qualified electrical personnel. • Failure to follow these warnings could result in serious personal injury.
	<p>PRESSURIZED SYSTEM HAZARD</p> <ul style="list-style-type: none"> • System contains refrigerant and oil under pressure. • Remove refrigerant from both the high and low compressor side before removing compressor. • Use appropriate backup wrenches on rotalock fittings when servicing. • Never install a system and leave it unattended when it has no charge, a holding charge, or with the service valves closed without electrically locking out the system. • Use only approved refrigerants and refrigeration oils. • Personal safety equipment must be used. • Failure to follow these warnings could result in serious personal injury.
	<p>BURN HAZARD</p> <ul style="list-style-type: none"> • Do not touch the compressor until it has cooled down. • Ensure that materials and wiring do not touch high temperature areas of the compressor. • Use caution when brazing system components. • Personal safety equipment must be used. • Failure to follow these warnings could result in serious personal injury or property damage.
	<p>COMPRESSOR HANDLING</p> <ul style="list-style-type: none"> • Use the appropriate lifting devices to move compressors. • Personal safety equipment must be used. • Failure to follow these warnings could result in personal injury or property damage.

Safety Statements

- Refrigerant compressors must be employed only for their intended use.
- Only qualified and authorized HVAC or refrigeration personnel are permitted to install, commission and maintain this equipment.
- Electrical connections must be made by qualified electrical personnel.
- All valid standards and codes for installing, servicing, and maintaining electrical and refrigeration equipment must be observed.

1. Introduction and Features

Using the Electronic Unit Controller with Copeland™ brand condensing units will provide many benefits to the contractor and end-user. It has been designed specifically for demanding refrigeration applications to ensure precision in installation and operation. While the Electronic Unit Controller will replace existing adjustable low-pressure controls, fan cycle switches, and other relays, it also has additional features. These features include bump start (where applicable), data storage, and short cycling protection. This controller does NOT replace the fixed high-pressure control required by UL.

The Electronic Unit Controller can be used on any condensing unit application with the appropriate sensors and relays that will be factory installed on the condensing unit. This document will explain how Electronic Unit Controllers affect the installation process and how they can assist in troubleshooting.

Factory-installed controllers are pre-programmed with the proper settings, resulting in little to no setup time. The unit comes with an attached label showing how to adjust the low pressure cut-in and cut-out (See **Figure 1**).

There is a label on the inside of the enclosure which will list all of the factory default settings for the controller (including those not adjustable), a basic controller wiring schematic, basic button descriptions, the controller part number, the pre-loaded program part number, and contact information (See **Figure 2**). This information can be used if a service replacement controller is needed.



Figure 1

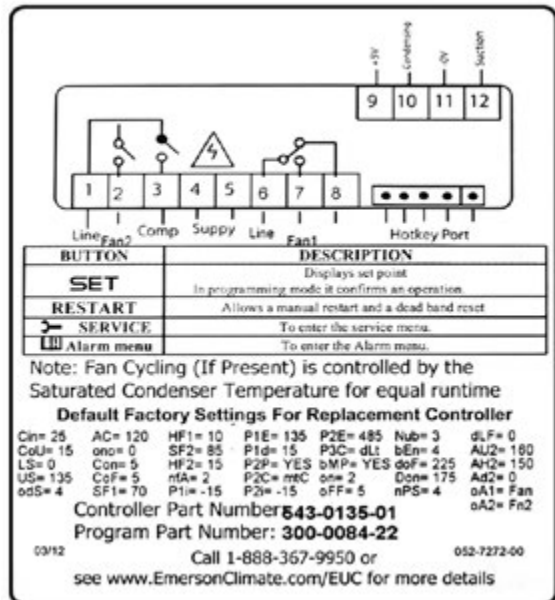

Figure 2 example

AE8-1376 R5

May 2016

1.1 Technical Specifications

Mounting: Panel mounting in a 71x29mm panel cut-out

Controller IP Rating: IP20

Front Panel IP rating: IP65

Power supply: 208/230Vac $\pm 10\%$, 50/60Hz
120Vac $\pm 10\%$, 50/60Hz

Power absorption: 3VA max

Relay outputs:

Compressor Relay: 250VAC, 16A FLA, 96A LRA

Fan Relay 1: 250VAC, 4.9 FLA, 29.4 LRA

Fan Relay 2: 250VAC, 1.9 FLA, 11.4 LRA

SPECIAL NOTE: EUC FAN CYCLING RELAYS ARE NOT APPROVED FOR USE WITH ECM MOTORS

Data storage: Non-volatile memory (EEPROM).

Rated impulsive voltage: 2500V; Overvoltage Category: II

Factory Installed Operating Range: -40 – 120°F Ambient

Non-Factory Installed Operating Range: -4 to 120°F Ambient

1.2 Pressure Probe Error Bypass

In the event where suction pressure rises above the controller's maximum value of 135 PSIG (this frequently happens during cleaning cycles or other off-cycle conditions), the controller will enter a pressure probe bypass mode during startup to allow the system to stabilize pressures. The controller will flash "135" on the display and the compressor will run continuously unless stopped by a high-pressure or temperature control. If suction pressure remains above 135 PSIG for more than 15 minutes, the controller will flash "P1" on the display and cycle the compressor on and off according to the time set with the "Con" and "Cof" parameters. These are set to 5 minutes by default and can be adjusted in the Advanced Options Menu (See **Section 2.6**).

1.3 Bump Start

Bump start is an optional feature which provides additional flooded start protection. Bump start drives refrigerant out of the oil, preventing the refrigerant from circulating through the compressor as a liquid and washing the oil film off of the load-bearing surfaces.

When bump start is enabled, the compressor is turned on for 2 seconds, then turned off for 5 seconds. This occurs 3 times before the compressor runs normally. This allows refrigerant to exit the compressor without the oil being removed.

Bump start can be turned on in the Advanced Options Menu by changing "bNP" to "Y" (See **Section 2.6**).

2. Installation and Controller Operation Instructions

2.1 Condensing Unit Installation Instructions

Customer connections will not change, and in most cases, wiring to the unit will not change either. See **Section 6** for more information.

If the unit trips on low pressure during charging, the low pressure cut-out can be lowered to allow it to run. Be sure to adjust it back to the proper application setting after charging. See the appropriate Application Engineering Bulletin.

2.2 Controller Display

The controller display is shown in **Figure 4**, below. **Table 1** provides a description of each of the labeled lights. The controller is defaulted to display the current suction pressure to three significant digits in pounds per square inch gage (PSIG).

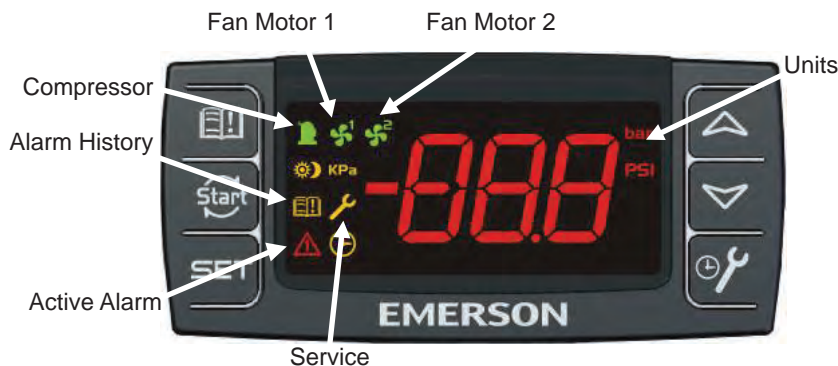









Figure 4 -- Controller Display

Table 1 – LED Descriptions

LED	Mode	Function
	ON	Compressor on
	Flashing	Anti-short cycle delay enabled
	ON	Fan 1 on
	ON	Fan 2 on
PSI	ON	Pressures displayed in PSIG
PSI	Flashing	Programming mode
	ON	Browsing service menu
	Flashing	New alarm indication
	ON	Browsing alarm menu
	ON	An alarm is occurring

2.3 Button Descriptions and Key Combinations

Table 2 lists the different buttons on the controller (See **Figure 4**) and their functions. **Table 3** lists the different key combinations and their functions.

Table 2 – Button Descriptions











Button	Description
SET	Displays set point. In programming mode, it confirms an operation.
	When held for 3 seconds, it overrides cut-in value and starts compressor. When DLL or HPL lockout condition occurs, it resets lockout condition when held for 3 seconds 2 consecutive times (if temperatures or pressures exceed cut-out trip point values, pressing  button will not clear the fault).
 (UP)	Displays current condenser temperature. In programming mode, it browses parameters or increases the displayed parameter value.
 (DOWN)	Displays current discharge temperature. In programming mode, it browses parameters or decreases the displayed parameter value.
 Alarm Menu	Enters Alarm menu (See Section 3).
 SERVICE Menu	Enters SERVICE menu (See Section 4).

Table 3 – Key Combinations

Key Combinations	
	Locks and unlocks the keypad.
SET + 	Enters programming mode.
SET + 	Returns to suction pressure display.

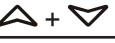
2.4 Viewing Temperature Readings





1. Press  button to view condenser temperature.
2. Press  button to view discharge temperature.

2.4.1 Viewing Setpoints

1. Press and immediately release **SET** button: the display will show the “Cin” message.
2. Press **SET** button to see the setpoint value.
3. Press and immediately release **SET** button: the display will show the “CoU” message.
4. Press **SET** button to see the setpoint value.

2.5 Changing a Parameter Value

To change a parameter value, do the following:

1. Hold down **SET** +  keys for 3 seconds, or until the “PSI” LED starts blinking, to enter the Programming Menu.
2. Press  or  button to select the required parameter. Press **SET** button to display parameter value.
3. Press  or  button to change parameter value.
4. Press **SET** button to store the new parameter value.

TO EXIT: Press **SET** +  keys or wait up to 30 seconds without pressing a button or key.

NOTE: The set value is stored, even when the procedure is exited, by waiting for the time-out to expire.





2.6 Entering the Advanced Options Menu

The Advanced Options Menu will be locked 5 minutes after the controller is powered. If access to the Advanced Options Menu is needed, cycle power to the controller.

1. Hold down **SET** +  keys for 3 seconds, or until the “PSI” LED starts blinking, to enter the Programming Menu.

2. Release keys, then hold down **SET** +  keys again for at least 7 seconds. The “PR2” label will be displayed immediately followed by the “Ci.n” parameter.

NOTE: THIS IS THE ADVANCE OPTIONS MENU.

3. Press  or  button to select the required parameter.
4. Press **SET** button to display parameter value.
5. Press  or  button to change parameter value.
6. Press **SET** button to store the new parameter value.

TO EXIT: Press **SET** +  keys or wait up to 30 seconds without pressing a button or key.

NOTE: If no parameter is present in “PR1” after 3 seconds, the controller will display the “noP” message. Keep the keys pushed until the “PR2” message is displayed.

NOTE: The set value is stored, even when the procedure is exited, by waiting for the time-out to expire.

2.6.1 Moving Parameters between Programming Menu and Advanced Options Menu

While in the Advanced Options Menu, certain parameters will have a period between the 2nd and 3rd characters. For example: “Ci.n”. These parameters are in both the Programming and Advanced Options menus.

To add or remove a parameter from the Programming Menu, do the following:

1. Enter the Advanced Options Menu and select the required parameter (See **Section 2.6, steps 1 through 3**).
2. With the required parameter displayed, press **SET** +  keys.

NOTE: A period will be added or removed between the 2nd and 3rd characters of the selected parameter.

TO EXIT: Press **SET** +  keys or wait up to 30 seconds without pressing a button or key.

2.6.2 Programming Using a Hotkey

Hotkeys can be used to store the user’s custom parameters. To upload parameters to a hotkey, do the following:

1. Turn controller ON.
2. Ensure controller is programmed as desired.
3. Disconnect 5-pin harness from rear of controller (See **Figure 5**).
4. Insert hotkey into 5-pin receptacle on rear of controller (See **Figure 5**).
5. Press **▲** + **⏏** keys; controller will blink “uPI” and then display the “End” message.
6. Press **SET** button; “End” message will disappear.
7. Turn controller OFF.
8. Remove hotkey from rear of controller (See **Figure 5**).
9. Connect 5-pin harness to rear of controller (See **Figure 5**).
10. Turn controller ON.

NOTE: If controller displays an “Err” message, programming has failed. Repeat steps 1-9 to restart upload process. Remove hotkey to abort.

To program controller using a hotkey, do the following:

1. Turn controller OFF.
2. Disconnect 5-pin harness from rear of controller (See **Figure 5**).
3. Insert pre-programmed hotkey into 5-pin receptacle on rear of controller (See **Figure 5**).
4. Turn controller ON.

NOTE: The download is successful when the following happens:

- a. Controller blinks “dol” and displays “End.” message.
- b. After 10 seconds, the controller goes back to the default display (suction pressure).

5. Remove hotkey from rear of controller (See **Figure 5**).
6. Connect 5-pin harness to rear of controller (See **Figure 5**).

NOTE: If controller displays an “Err” message, programming has failed. Cycle power to controller to restart download process. Remove hotkey to abort.

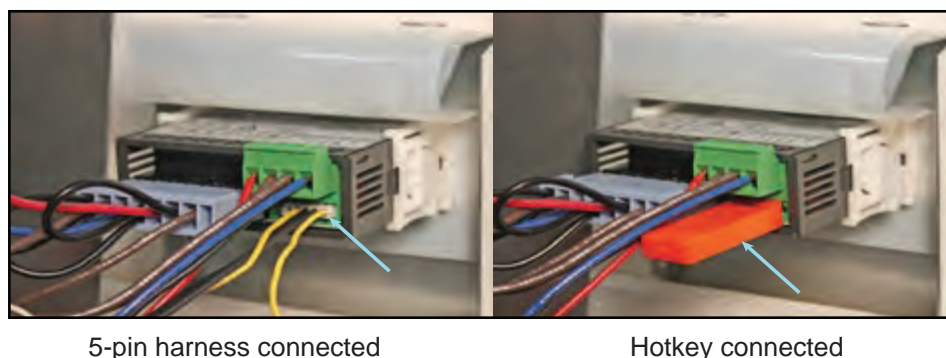



Figure 5 – Programming Using a Hotkey

2.7 Locking the Keypad

1. Press  +  keys for more than 3 seconds.



NOTE: Controller will display “POF” message when keypad is locked. While keypad is locked, only set points can be viewed. If a key is pressed for more than 3 seconds, controller will display “POF” message.

2.8 Unlocking the Keypad



1. Press  +  keys for more than 3 seconds, until controller displays “Pon” message.

2.9 Resetting Alarm and Runtime Counters

See **Sections 3 and 4** for more information on Alarm and Service menus. The Advanced Options Menu will be locked for 5 minutes after the controller is powered. If counters need to be reset during this time, cycle power to the controller.

1. Hold down **SET** +  keys for 3 seconds, or until the “PSI” LED starts blinking, to enter the Programming Menu.
2. Release keys, then hold down **SET** +  keys again for at least 7 seconds. The “PR2” label will be displayed immediately followed by the “Ci.n” parameter.

NOTE: THIS IS THE ADVANCED OPTIONS MENU.

3. Press  or  button to select the required parameter, listed below:
 - rSA – Reset Alarm Counters (HP, dlt, and Loc)
 - rCA – Reset Compressor Starts Counters
 - rCH – Reset Compressor Run Hours Counters
 - rFH – Reset Fan Run Hours Counters
4. Press **SET** button to display counter values.
5. Press  button to change “n” to “Y.”
6. Press **SET** button to store new value and reset counter.
7. Repeat steps 3 through 6 to reset other counters.

3. Alarm Menu

The controller records the activations of the following alarms in the Alarm menu:

- High pressure trips (up to 999) – HP
- High DLT temperature alarm (up to 999) – dlt
- Total number of manual restarts (HPL and dLL) (up to 255) – Loc

To view alarm counters, do the following:

1. Press and release the  button; controller will display the “HP” label.
2. With controller displaying the “HP” label, press **SET** button to see the number of high pressure trips.
3. With controller displaying the “dlt” label, press **SET** button to see the number of DLT trips.
4. With controller displaying the “Loc” label, press **SET** button to see the number of manual resets.

4. Service Menu

The controller stores the following values in the SERVICE menu:

- **Number of compressor starts:**
StH (0-999; resolution 1,000);
Stl (0-999; resolution 1) -
Example: If StH = 12 and Stl = 500:
Total number of compressor starts = 12,500
- **Compressor run hours:**
CHH (0-65; resolution 1,000);
CHL (0-999; resolution 1) -
Example: If CHH = 8 and CHL = 500:
Total number of compressor run hours = 8,500
- **Fan motor 1 run hours:**
F1H (0-65; resolution 1,000);
F1L (0-999 resolution 1)
- **Fan motor 2 run hours:**
F2H (0-65; resolution 1,000);
F2L (0-999 resolution 1)

To view service counters, do the following:

1. Hold down  button for 3 seconds.
2. Press **SET** button to view selected service counters. See the above list for counter names and meanings.

5. Parameter List

All parameters and their descriptions, default values, and operating ranges are listed in **Tables 4** and **5**. Depending on the condensing unit model, some parameter values may be different than shown or not applicable.

Table 4 – Parameters

Label	Description	Default	Range
Default Display Value			
	Current Suction Pressure (PSIG)		
Adjustable In Programming Menu			
Cin	Compressor cut-in (PSIG)	25	CoU - US
CoU	Compressor cut-out (PSIG)	15	LS - Cin
Adjustable From Advanced Options Menu			
odS	Outputs delay at start up (seconds) (Only adjustable on single phase scroll units)	2 or 4	2 - 255
AC	Anti-short cycle delay (Minimum time between compressor off then on) (seconds)	6	6 - 900
Con	Compressor ON time with faulty probe (minutes)	5	0 - 255
CoF	Compressor OFF time with faulty probe (minutes)	5	0 - 255
P1F	Suction Pressure Transducer Offset (PSI)	0	-120 -120
bNp	Bump start enabled	no	no - YES
nPs	Number of activations of DLT alarm in a hour to lock compressor (Units with discharge line temperature protection only)	4	0-15; 0 = always automatic restart
HPn	UL safety digital input activation before compressor lock (Units with fixed high pressure controls only)	5	0-15; 0 = always automatic restart
SF1	Fan 1 Cut-out (°F) (Fan cycling units only)	70	-40 - SF2
HF1	Fan 1 differential (°F) (Fan cycling units only)	10	1 -100
SF2	Fan 2 Cut-out (°F) (Fan cycling units only)	85	SF1 - 230
HF2	Fan 2 differential (°F) (Fan cycling units only)	15	1 - 100
rSA	Reset Alarm Counters (HP, dLt, and Loc)		
rCA	Reset Compressor Starts Counters		
rCH	Reset Compressor Run Hours Counters		
rFH	Reset Fan Run Hours Counters (Fan cycling units only)		



Table 5 – Factory Set Parameters

Label	Description	Default	Range
Factory Set Definitions			
LS	Minimum set point (PSIG)	-7 or 5	-7 - US
US	Maximum set point (PSIG)	135	LS - 135
ono	Minimum time between two compressor starts (minutes)	0	0 - 15
nFA	Number of fans on during probe fault	2	0 - 2
Unt	Measurement unit for pressure: PSIG, bar, kPA	PSI	PSI, bAr, HPA
CF	Measurement unit for temperature	F	C or F
on	Bump Start Compressor on time (seconds)	2	1 - 15
off	Bump Start Compressor off time (seconds)	5	1 - 15
nUb	Number of cycles during bump start	3	1 - 15
bEn	Compressor stop time for next bump start (hours)	4.0	1.0 - 23.5
doF	DLT alarm temperature to stop compressor (°F)	220	don - 302
don	DLT temperature for compressor restart (°F)	170	-58 - doF
ALd	DLT stop compressor delay (seconds)	0-5	0 - 255
dIF	Minimum time of compressor off with dLL alarm (minutes)	0	0 - 15
AU2	Cut-in for Condenser Temperature/Pressure alarm (°F)	150	AH2 - 230
AH2	Cut-out for high Condenser Temperature/Pressure alarm (°F)	140	-40 - AU2
Ad2	High condenser temperature alarm delay (minutes)	0	0 - 255
HPF	Minimum off time after a High-Pressure Trip (minutes)	5	0 - 15
P1i	Start scale for probe 1 (PSIG)	-15	-15 to P1E
P1E	End scale for probe 1 (PSIG)	135	P1i to 999
P1d	P1 alarm display delay, with P1C=0-5V (min)	0	0 -100
P2P	Probe 2 presence		YES, NO
P2C	Probe 2 configuration		NTC, 0-5
P2i	Start scale for probe 2 (PSIG)	-15	-15 to P2E
P2E	End scale for probe 2 (PSIG)	485	P2i to 999
P3C	Probe 3 configuration		Nu, DLT, CPA
Ab2	High condenser temperature alarm with compressor off		Yes, No
oA1	AUX 1 configuration		Fan, Fn2, Alr
oA2	AUX 2 configuration		Fan, Fn2, Alr

6. Controller Wiring



Always disconnect and lockout the power supply before beginning electrical installations or troubleshooting.

6.1 Non-Fan Cycling Wiring Schematic

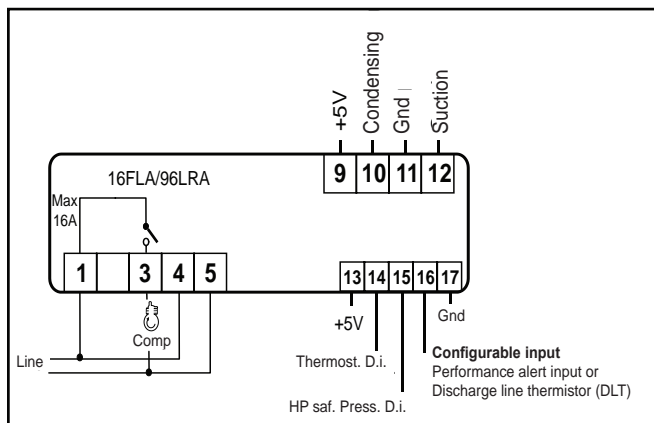

Figure 6 – Non-Fan Cycling Wiring Schematic

Compressor: Use terminals 1-3.

Power Supply: Use terminals 4-5 (terminals 4 and 5 are for power supply at 110VAC or 230VAC, depending on the model).

Suction Pressure Transducer: Use terminal 9 (+5V) for supply, terminal 11 for ground, and terminal 12 for signal.

Condenser Temperature Sensor: Connect probe to terminal 11 (ground) and 10.

Thermostat Digital Input: Use terminals 14-17.

UL HP input: Use terminals 15-17.

DLT Sensor: Connect probe to terminals 16-17.

Copeland PerformanceAlert (CPA): See Figure 8.

6.2 Fan Cycling Wiring Schematic

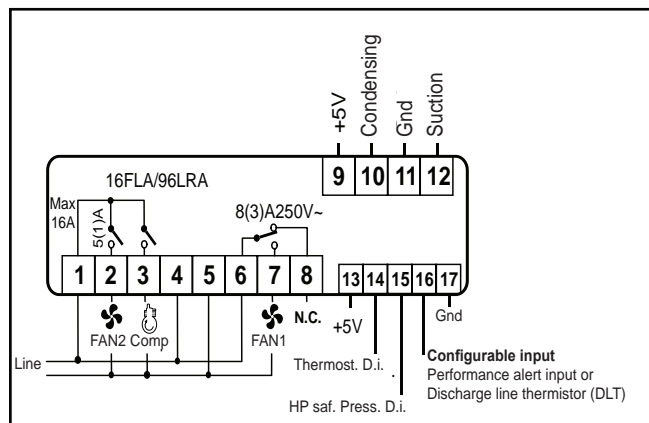

Figure 7 – Fan Cycling Wiring Schematic

Compressor: Use terminals 1-3.

Power Supply: Use terminals 4-5 (terminals 4 and 5 are for power supply at 110VAC or 230VAC, depending on the model).

FAN 1: Use terminals 6-7.

FAN 2: Use terminals 1-2.

Suction Pressure Transducer: Use terminal 9 (+5V) for supply, terminal 11 for ground, and terminal 12 for signal.

Condenser Temperature Sensor: Connect probe to terminal 11 (ground) and 10.

Thermostat Digital Input: Use terminals 14-17.

UL HP input: Use terminals 15-17.

DLT Sensor: Connect probe to terminals 16-17.

Copeland PerformanceAlert (CPA): See Figure 8.

AE8-1376 R5

May 2016

6.3 Copeland PerformanceAlert Connection

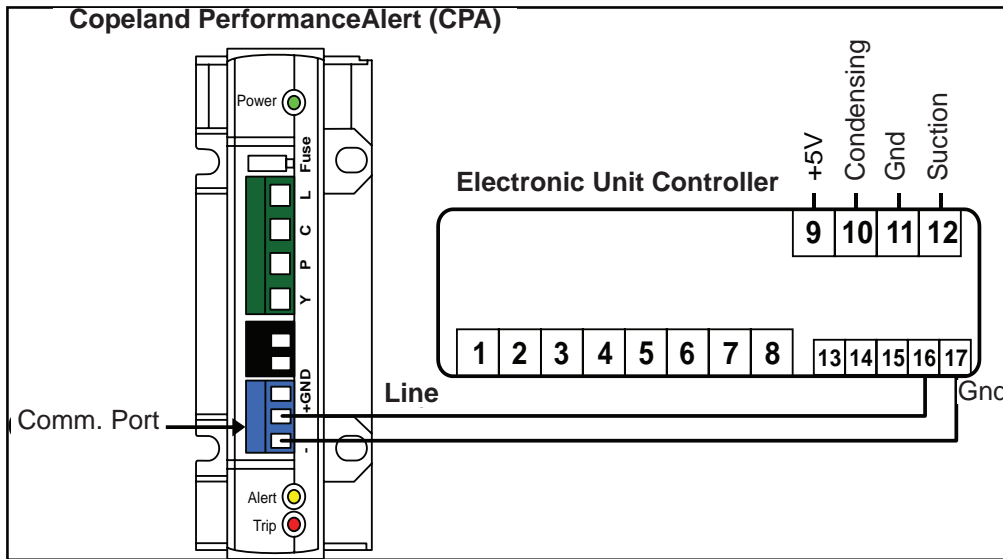

Figure 8 – Wiring Schematic Example for Controller with Copeland PerformanceAlert

Copeland PerformanceAlert (CPA) connection: Use terminals 16-17. Connect the CPA as shown in **Figure 8**. For more information on PerformanceAlert, see Application Engineering Bulletin AE8-1347.

6.4 Additional Controller Inputs

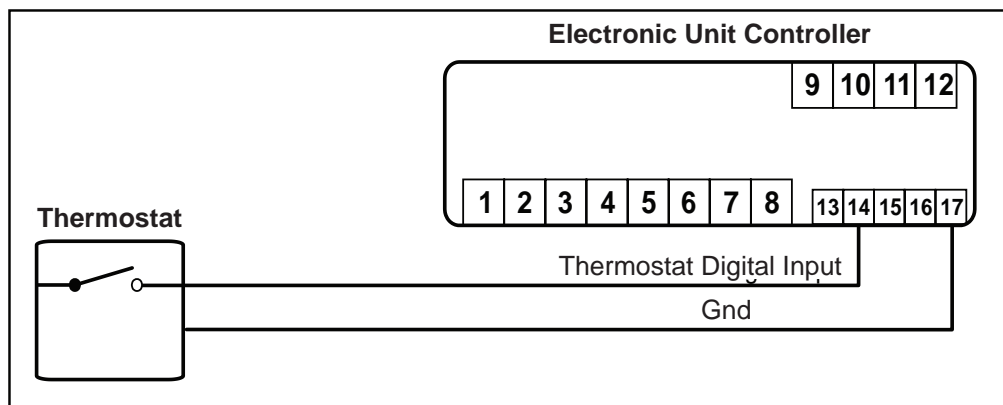

Figure 9 – Wiring Schematic Example for Optional Thermostat

If another device, such as a thermostat, will be used to control the condensing unit, terminals 14 and 17 need to be connected to a dry contact (no voltage). The additional controller (thermostat) provides voltage to the dry contact.

Terminals 14 and 17 are located on the hotkey cable and will be connected together by push-on type connectors. See **Figures 6, 7, 8, and 9** for wiring details.

NOTE: If using a control (e.g., thermostat) with another device (e.g., pump down solenoid), no connections to the controller are required.

AE8-1376 R5

May 2016

7. Alarms and Notifications

In the event of an issue or fault, the codes listed below will flash to indicate the alarm condition. See **Section 9** for troubleshooting information.

Table 6 – Alarms and Notifications

Code	Description
PoF	Keypad locked
Pon	Keypad unlocked
P1	Suction probe failure
P2	Condenser probe failure
P3	DLT probe failure
HA	High condenser temperature alarm
dlt	DLT temperature alarm
dll	DLT lock alarm
HP	High-pressure trip alarm
HPL	High-pressure trip lockout alarm
CPA	Copeland PerformanceAlert not connected properly
EE	Electronic Unit Controller failure
CH	Compressor working hour counter alarm
FH	Fan working hour counter alarm
HdL	Maximum alarm count has been reached - alarm counters need to be reset

If a Copeland PerformanceAlert* module is installed in the unit, PerformanceAlert error codes will be displayed on the controller screen. This eliminates the need to count lights flashed on the PerformanceAlert module itself. For more information on PerformanceAlert, see Application Engineering Bulletin **AE8-1347**.

Table 7 – Copeland PerformanceAlert Error Codes

Code	Three Phase Recip.	Three Phase Scroll	Single Phase
C01	Discharge Temperature Trip	Discharge Temperature Trip	Discharge Temperature Trip
C02	System Trip	System Trip	System Trip
C03	Short Cycling	Short Cycling	Short Cycling
C04	Locked Rotor	Locked Rotor	Locked Rotor
C05	Open Circuit	Open Circuit	Open Circuit
C06	Missing Phase	Missing Phase	Open Start
C07	N/A	Reverse Phase	Open Run
C08	Welded Contactor	Welded Contactor	Welded Contactor
C09	Low Voltage	Low Voltage	Low Voltage
C10	Lost Communications	Lost Communications	Lost Communications
C11	DLT Sensor Failure	DLT Sensor Failure	DLT Sensor Failure

*Copeland PerformanceAlert is not replaced by the Electronic Unit Controller. The PerformanceAlert module includes many features not included in the Electronic Unit Controller, such as locked rotor protection, loss of phase, etc. The Electronic Unit Controller is able to interface with PerformanceAlert to display error codes in an easy-to-read format.

AE8-1376 R5

May 2016

7.1 Discharge Line Temperature Protection

The Electronic Unit Controller uses a temperature sensor, which allows for more flexibility in what the controller can do. If the unit trips, the unit will display an error code and log that an error has occurred. In addition, the controller will allow an automatic reset up to 4 times per hour. On the fourth trip, the controller will require a manual reset. The parameter “nPS” can be changed in the Advanced Options Menu (see **Section 2.6**) to adjust the total number of trips allowed in an hour before a lockout. If an automatic reset is always needed, parameter “nPS” can be set to 0.

Controllers built in September 2015 and after are programmed with a higher discharge line cut-out temperature and a 5 second trip delay, reducing nuisance trips.

NOTE: If nuisance trips are occurring on controllers built before September 2015 (15I date code), contact application engineering for support.

Controllers built before September 2015:

Default Discharge Line Cut-in Temp:	170°F
Default Discharge Line Cut-out Temp:	220°F
Trip Delay:	N/A

Controllers built September 2015 and after:

Default Discharge Line Cut-in Temp:	170°F
Default Discharge Line Cut-out Temp:	225°F
Trip Delay:	5 seconds

7.2 UL High Pressure Safety Control

High-pressure control is a UL (Underwriters Laboratories) safety device. As such, Emerson Climate Technologies condensing units equipped with the Electronic Unit Controller still come with the high-pressure mechanical control installed on the unit. The high-pressure controls will all be fixed to work with the control, and the value of the cut-out will be determined by the working pressure of the high side of the condensing unit. This should have no affect on a customer’s UL requirements.

The high-pressure control will break power to the compressor output relay, which will shut down the compressor regardless of the program state. This change will also allow the controller to read the high-pressure control state and display the appropriate error codes. In addition, the controller will allow an automatic reset up to 4 times per hour. On the fifth trip, the controller will require a manual reset. The parameter “HPn” can be changed in the Advanced Options Menu (See **Section 2.6**) to adjust the total number of trips allowed in an hour before a lockout. If an always automatic reset is needed, parameter “HPn” should be set to 0.

AE8-1376 R5

May 2016

8 Electronic Unit Controller Replacement

⚠ WARNING

Electronic Unit Controller replacement must be performed in accordance with safety instructions. **Disconnect and lockout power before servicing.** See **Safety** section for additional information.

8.1 Silver Electrical Box Applications



Figure 10 – Silver Electrical Box

1. Disconnect main power source.
2. Remove electrical box cover.
3. Remove Electronic Unit Controller assembly and rotate it up 90 degrees. The assembly should now slide and clip onto the top of the electrical box, leaving the wiring harnesses exposed.

4. Disconnect three wiring harnesses from rear of controller.
5. Verify replacement controller and existing controller have the same part number (e.g., part number: 543-0133-00).
NOTE: A controller with a part number ending in -00 may be replaced with a controller with a part number ending in -01 or -02 (See **Section 8.5**).
6. Insert replacement controller through the slot. Ensure controller wiring schematic is pointing away from the operator.
7. Connect three wiring harnesses to rear of controller. Ensure the part number on the blue harness is facing towards the operator.
8. Unclip Electronic Unit Controller assembly from the top of the electrical box and slide it back into its original position.
9. Install electrical box cover.
10. Connect main power source.
11. Set controller parameters to match values listed on inside label (See **Section 8.4**).

AE8-1376 R5

May 2016

8.2 Small Black Electrical Box Applications



Figure 11 – Small Black Electrical Box

1. Disconnect main power source.
2. Remove electrical box cover.
3. Bend the metal tabs on either side of the controller outward and pull controller approximately halfway out.
4. Disconnect three wiring harnesses from rear of controller.
5. Completely remove controller from assembly.
6. Verify replacement controller and existing controller have the same part number (e.g., part number: 543-0133-00).
NOTE: A controller with a part number ending in -00 may be replaced with a controller with a part number ending in -01 or -02 (See **Section 8.5**).
7. Bend the metal tabs on either side of the empty slot inward prior to installing replacement controller.
8. Insert replacement controller through the slot with label facing away. Push controller halfway in.
9. Connect three wiring harnesses to rear of controller. Ensure controller wiring schematic is pointing away from the operator.
10. Finish installing replacement controller in assembly.
11. Install electrical box cover.
12. Connect main power source.
13. Set controller parameters to match values listed on inside label (See **Section 8.4**).

8.3 Plastic Retainer Applications (Large Black Electrical Box and X-Line Units)



Figure 12 – Large Black Electrical Box

1. Disconnect main power source.
2. Remove electrical box cover.
3. Disconnect three wiring harnesses from rear of controller.
4. Press the centers of the white plastic connectors and pull them straight out.
5. Remove controller.
6. Verify replacement controller and existing controller have the same part number (e.g., part number: 543-0133-00).
NOTE: A controller with a part number ending in -00 may be replaced with a controller with a part number ending in -01 or -02 (See **Section 8.5**).
7. Insert replacement controller through the slot. Ensure controller wiring schematic is facing up.
8. Secure controller with white retainer clips.
9. Connect three wiring harnesses to rear of controller. Ensure part label on blue wiring harness is facing down.
10. Install electrical box cover.
11. Connect main power source.
12. Set controller parameters to match values listed on inside label (See **Section 8.4**).

AE8-1376 R5



May 2016

8.4 Setting Controller Parameters After Replacement



Control settings vary for each condensing unit model. The replacement controller must be programmed for the condensing unit to function properly.

See the provided programming instruction label (052-7272-00) or wiring schematic (X-Line units only) for a list of default parameter values.

To program a replacement controller with default parameter values, do the following:



1. Hold down **SET** +  keys for 3 seconds, or until the “PSI” LED starts blinking, to enter the Programming Menu.
2. Release keys, then hold down **SET** +  keys again for at least 7 seconds. The “PR2” label will be displayed immediately followed by the “Ci.n” parameter.

NOTE: THIS IS THE ADVANCED OPTIONS MENU.

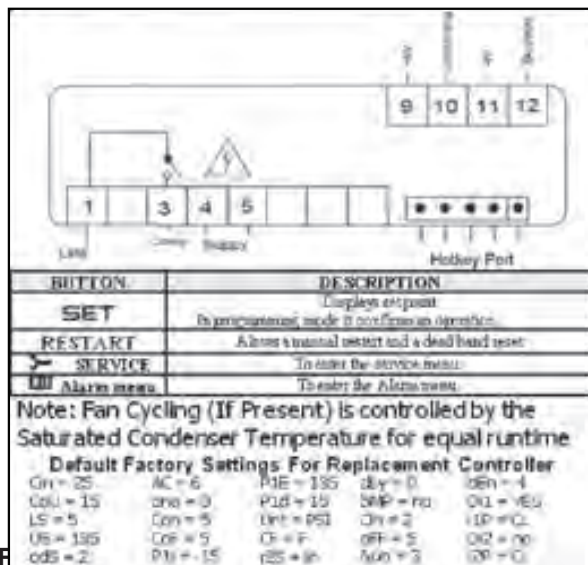
3. Press  or  button to select the required parameter.
4. Press **SET** button to display parameter value.
5. Compare displayed values with the values on the provided label (See **Figure 13**).



Schematic on Inside Label

6. Press  or  button to change parameter value, if needed.
7. Press **SET** button to store the new parameter value, if needed.

8. Repeat steps 3 through 7 as needed to complete the process.

TO EXIT: Press **SET** +  keys or wait 15 seconds without pressing a button or key.

8.5 Replacing -00 Controller with -01 or -02 Controller

1. Check to see if there is a blue wire in the jumper cable (See **Figure 14**).

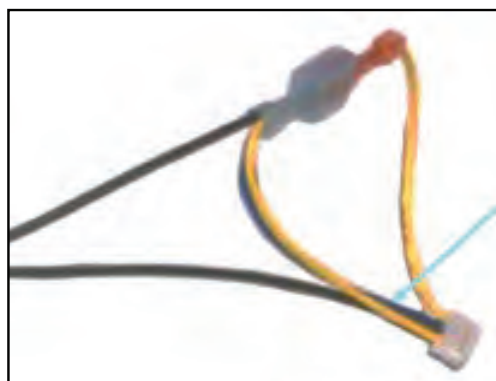

Figure 14 – Jumper Cable with Blue Wire

- If blue wire is present, continue with controller replacement.
- If blue wire is not present, use the jumper cable supplied with the replacement controller kit and continue with controller replacement.

NOTE: If the jumper cable without a blue wire is not replaced, replacement controller will flash “HP” error code and will not operate.

NOTE: The replacement jumper cable includes a discharge line temperature probe. If condensing unit is not equipped with discharge temperature protection, secure discharge line temperature probe to jumper cable using a cable tie.

AE8-1376 R5

May 2016

Deg C	Deg F	Resistance (kOhms)	Deg C	Deg F	Resistance (kOhms)	Deg C	Deg F	Resistance (kOhms)	Deg C	Deg F	Resistance (kOhms)
-50	-58	329.5	-8	18	38.77	34	93	7.192	76	169	1.869
-49	-56	310.9	-7	19	37.06	35	95	6.94	77	171	1.816
-48	-54	293.5	-6	21	35.44	36	97	6.699	78	172	1.765
-47	-53	277.2	-5	23	33.9	37	99	6.467	79	174	1.716
-46	-51	262	-4	25	32.44	38	100	6.245	80	176	1.668
-45	-49	247.7	-3	27	31.05	39	102	6.032	81	178	1.621
-44	-47	234.3	-2	28	29.73	40	104	5.827	82	180	1.577
-43	-45	221.7	-1	30	28.48	41	106	5.629	83	181	1.533
-42	-44	209.9	0	32	27.28	42	108	5.438	84	183	1.491
-41	-42	198.9	1	34	26.13	43	109	5.255	85	185	1.451
-40	-40	188.5	2	36	25.03	44	111	5.08	86	187	1.411
-39	-38	178.5	3	37	23.99	45	113	4.911	87	189	1.373
-38	-36	169	4	39	23	46	115	4.749	88	190	1.336
-37	-35	160.2	5	41	22.05	47	117	4.593	89	192	1.3
-36	-33	151.9	6	43	21.15	48	118	4.443	90	194	1.266
-35	-31	144.1	7	45	20.3	49	120	4.299	91	196	1.232
-34	-29	136.7	8	46	19.48	50	122	4.16	92	198	1.2
-33	-27	129.8	9	48	18.7	51	124	4.026	93	199	1.168
-32	-26	123.3	10	50	17.96	52	126	3.896	94	201	1.137
-31	-24	117.1	11	52	17.24	53	127	3.771	95	203	1.108
-30	-22	111.3	12	54	16.56	54	129	3.651	96	205	1.079
-29	-20	105.7	13	55	15.9	55	131	3.536	97	207	1.051
-28	-18	100.5	14	57	15.28	56	133	3.425	98	208	1.024
-27	-17	95.52	15	59	14.69	57	135	3.318	99	210	0.9984
-26	-15	90.84	16	61	14.12	58	136	3.215	100	212	0.9731
-25	-13	86.43	17	63	13.58	59	138	3.116	101	214	0.9489
-24	-11	82.26	18	64	13.06	60	140	3.02	102	216	0.9246
-23	-9	78.33	19	66	12.56	61	142	2.927	103	217	0.9014
-22	-8	74.61	20	68	12.09	62	144	2.838	104	219	0.8789
-21	-6	71.1	21	70	11.63	63	145	2.751	105	221	0.8572
-20	-4	67.77	22	72	11.2	64	147	2.668	106	223	0.836
-19	-2	64.57	23	73	10.78	65	149	2.588	107	225	0.8155
-18	0	61.54	24	75	10.38	66	151	2.511	108	226	0.7956
-17	1	58.68	25	77	10	67	153	2.436	109	228	0.7763
-16	3	55.97	26	79	9.632	68	154	2.364	110	230	0.7576
-15	5	53.41	27	81	9.281	69	156	2.295			
-14	7	50.98	28	82	8.944	70	158	2.228			
-13	9	48.68	29	84	8.622	71	160	2.163			
-12	10	46.5	30	86	8.313	72	162	2.1			
-11	12	44.43	31	88	8.014	73	163	2.039			
-10	14	42.47	32	90	7.728	74	165	1.98			
-9	16	40.57	33	91	7.454	75	167	1.924			

9.1 Thermistor Temperature/Resistance Values for Discharge Temperature Sensor

Deg C	Deg F	Resistance (kOhms)
-40	-40	2889.60
-35	-31	2087.22
-30	-22	1522.20
-25	-13	1121.44
-20	-4	834.72
-15	5	627.28
-10	14	475.74
-5	23	363.99
0	32	280.82
5	41	218.41
10	50	171.17
15	59	135.14
20	68	107.44
25	77	86.00
30	86	69.28
35	95	56.16
40	104	45.81
45	113	37.58
50	122	30.99
55	131	25.68
60	140	21.40
65	149	17.91

Deg C	Deg F	Resistance (kOhms)
70	158	15.07
75	167	12.73
80	176	10.79
85	185	9.20
90	194	7.87
95	203	6.77
100	212	5.85
105	221	5.09
110	230	4.45
115	239	3.87
120	248	3.35
125	257	2.92
130	266	2.58
135	275	2.28
140	284	2.02
145	293	1.80
150	302	1.59
155	311	1.39
160	320	1.25
165	329	1.12
170	338	1.01
175	347	0.92
180	356	0.83

10. Measuring Pressure/Voltage Values for Suction Pressure Transducer

To measure voltage to the suction pressure transducer manually, do the following:

1. Turn controller ON.
2. Monitor current suction pressure on controller display (See **Section 2.2**) and record reading.
3. Using a voltmeter, measure voltage between pin 12 and pin 11 on the top of the green-block-plug located on rear of controller (See **Figure 15**).
4. Compare suction pressure and voltage to the table below.

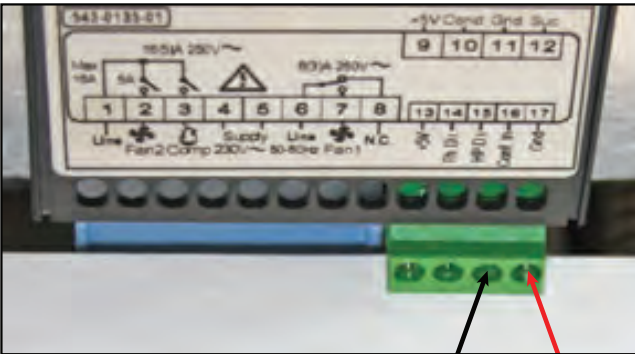

Figure 15 – Measuring Suction Pressure Transducer Voltage

DC Voltage	PSI
0.5	-15.0
0.6	-11.3
0.7	-7.5
0.8	-3.8
0.9	0.0
1	3.8
1.1	7.5
1.2	11.3
1.3	15.0
1.4	18.8
1.5	22.5
1.6	26.3
1.7	30.0
1.8	33.8
1.9	37.5
2	41.3
2.1	45.0
2.2	48.8
2.3	52.5
2.4	56.3

DC Voltage	PSI
2.5	60.0
2.6	63.8
2.7	67.5
2.8	71.3
2.9	75.0
3	78.8
3.1	82.5
3.2	86.3
3.3	90.0
3.4	93.8
3.5	97.5
3.6	101.3
3.7	105.0
3.8	108.8
3.9	112.5
4	116.3
4.1	120.0
4.2	123.8
4.3	127.5
4.4	131.3
4.5	135.0

9. Troubleshooting Guide

Display	Likely Causes	Other Possible Causes
Controller display remains blank after applying power	<ul style="list-style-type: none"> • Unit power not properly applied - check for proper applied voltage • Power cable harness not plugged in properly or securely into the back of the controller – check connections 	<ul style="list-style-type: none"> • Power cable miswired – inspect cable, replace if needed • Electrical assembly miswired – trace wiring diagrams
Controller displays correctly, but the green compressor light is off and the compressor is not running	<ul style="list-style-type: none"> • Jumper cable not plugged in properly or securely into the back of the controller – check connections • Controller is currently above the cut-in setting – check cut-in and cut-out settings 	<ul style="list-style-type: none"> • Jumper cable miswired – inspect cable, replace if needed
Controller displays correctly and the green compressor light is on and the compressor is not running	<ul style="list-style-type: none"> • Power cable harness not plugged in properly or securely into the back of the controller – check connections 	<ul style="list-style-type: none"> • Power cable not wired to the contactor or compressor correctly – check wiring • Power cable miswired – inspect cable, replace if needed
Controller flashes “135” or “P1”	<ul style="list-style-type: none"> • Current system pressure is above 135 PSIG – wait for system to pull down • Green harness not plugged in properly or securely into the back of the controller – check connections • Cable not connected properly with the pressure transducer – check connections 	<ul style="list-style-type: none"> • Transducer cable miswired – inspect cable, replace if needed • Damaged transducer – inspect transducer, replace if needed
Controller flashes “P2” on a unit with fan cycling	<ul style="list-style-type: none"> • Green harness not plugged in properly or securely into the back of the controller – check connections 	<ul style="list-style-type: none"> • Transducer cable miswired – inspect cable, replace if needed • Check condenser temperature sensor resistance values against table in Section 9.
Controller flashes “P2” on a unit without fan cycling after replacing a controller	<ul style="list-style-type: none"> • Controller not programmed properly – check parameters in Advanced Options Menu 	
Controller flashes “P3” on a unit with DLT	<ul style="list-style-type: none"> • Jumper cable not plugged in properly or securely into the back of the controller – check connections 	<ul style="list-style-type: none"> • Jumper cable miswired – inspect cable, replace if needed • Faulty DLT temperature sensor – check the discharge line temperature sensor resistance values against table in Section 9.
Controller flashes “P3” on a unit without DLT after replacing a controller	<ul style="list-style-type: none"> • Controller not programmed properly – check parameters in Advanced Options Menu 	

Troubleshooting Guide (continued)

Display	Likely Causes	Other Possible Causes
Fans not running on a fan cycling unit and the fan lights are not on	<ul style="list-style-type: none"> • Condensing temperature is currently below the fan cut-in • Condensing temperature sensor not properly installed – check installation 	<ul style="list-style-type: none"> • Transducer cable miswired – inspect cable, replace if needed. • Faulty temperature sensor – check condenser temperature sensor resistance values against table in Section 9.
Fans not running on a fan cycling unit and the fan lights are on	<ul style="list-style-type: none"> • Power cable harness not plugged in properly or securely into the back of the controller – check connections 	<ul style="list-style-type: none"> • Power cable miswired – inspect cable, replace if needed. • Electrical assembly miswired – trace wiring diagrams.
Controller flashes “HP” at power-up	<ul style="list-style-type: none"> • Jumper cable not plugged in properly or securely into the back of the controller – check connections • High pressure switch is seeing above the cut-out pressure • For a replacing an -00 controller, ensure that the jumper cable is the latest revision. It should have a blue wire in the harness. See Section 8.5 for more details. 	<ul style="list-style-type: none"> • Jumper cable miswired – inspect cable; replace if needed. • Faulty fixed Hp switch – inspect switch; replace if needed.
Controller flashes “HP” or “HPL”	<ul style="list-style-type: none"> • System operation causing high discharge pressures, check system operations 	<ul style="list-style-type: none"> • Bad high pressure switch – verify system pressure when the pressure switch trips. • See Section 7.2 for more details.
Controller flashes “DLT” or “DLL”	<ul style="list-style-type: none"> • System operation causing high discharge line temperatures, check system operations 	<ul style="list-style-type: none"> • Faulty temperature sensor – check DLT sensor values against table in Section 9. • See Section 7.1 for more details
Controller flashing “HPL” or “DLL”	<ul style="list-style-type: none"> • System operation causing high discharge pressures (HPL) or high discharge line temperatures (DLL) repeatedly, check system operations • To clear an HPL or DLL lockout, hold the Start button for 3 seconds 2 consecutive times, or cycle power to the unit. If using the reset button, the alarm condition will have to clear (DLT temperature drops or Hp switch resets) and any minimum off time will need to complete (5 minutes for the fixed Hp switch). 	

The contents of this publication are presented for informational purposes only and are not to be construed as warranties or guarantees, express or implied, regarding the products or services described herein or their use or applicability. Emerson Climate Technologies, Inc. and/or its affiliates (collectively “Emerson”), as applicable, reserve the right to modify the design or specifications of such products at any time without notice. Emerson does not assume responsibility for the selection, use or maintenance of any product. Responsibility for proper selection, use and maintenance of any Emerson product remains solely with the purchaser or end user.

AE8-1376 R5

May 2016

12. Parts Kits

Kit	Part Number	Description	Qty
943-0152-00 115V Non Fan Cycling Controller	543-0132-00/01/02	CONTROLLER	1
	529-0113-04	CABLE-SENSOR ASSM.	1
	032-7050-00	CLIP	2
	FM-2011IP-74	CONTROLLER FORM	1
943-0153-00 230V Non Fan Cycling Controller	543-0133-00/01/02	CONTROLLER - ELECT UN	1
	529-0113-04	CABLE-SENSOR ASSM.	1
	032-7050-00	CLIP	2
	FM-2011IP-74	CONTROLLER FORM	1
943-0154-00 115V Fan Cycling Controller	543-0134-00/01/02	CONTROLLER - ELECT UN	1
	529-0113-04	CABLE-SENSOR ASSM.	1
	032-7050-00	CLIP	2
	FM-2011IP-74	CONTROLLER FORM	1
943-0155-00 230V Fan Cycling Controller	543-0135-00/01/02	CONTROLLER - ELECT UN	1
	529-0113-04	CABLE-SENSOR ASSM.	1
	032-7050-00	CLIP	2
	FM-2011IP-74	CONTROLLER FORM	1
929-0113-00 White Input Sensor Cable Kit with DLT Sensor	529-0113-02	CABLE-SENSOR ASSM.	1
	529-0113-04	CABLE-SENSOR ASSM.	1
929-0114-00 Suction Pressure Transducer and Cables	039-0026-02	TRANSDUCER - PRESSUR	1
	529-0114-00	CABLE-SENSOR ASSM.	1
	529-0114-01	CABLE-SENSOR ASSM.	1
929-0114-01 Suction Pressure Transducer Cable with Condenser Temperature Sensor	529-0114-01	CABLE-SENSOR ASSM.	1
943-0037-00 115V Non Fan Cycling Stand Alone Kit	543-0132-03	CONTROLLER - ELECT UN	1
	032-7050-00	CLIP	2
	529-0113-02	CABLE-SENSOR ASSM.	1
	529-0114-00	CABLE-SENSOR ASSM.	1
	039-0026-02	TRANSDUCER - PRESSUR	1
	AE8-1376	AE BULLETIN	1

AE8-1376 R5

May 2016

Kit	Part Number	Description	Qty
943-0037-01 230V Non Fan Cycling Stand Alone Kit	543-0133-03	CONTROLLER - ELECT UN	1
	032-7050-00	CLIP	2
	529-0113-02	CABLE-SENSOR ASSM.	1
	529-0114-00	CABLE-SENSOR ASSM.	1
	039-0026-02	TRANSDUCER - PRESSUR	1
	AE8-1376	AE BULLETIN	1
943-0037-02 115V Pressure Based Fan Cycling Stand Alone Kit	543-0134-03	CONTROLLER - ELECT UN	1
	032-7050-00	CLIP	2
	529-0113-02	CABLE-SENSOR ASSM.	1
	529-0114-00	CABLE-SENSOR ASSM.	1
	039-0026-02	TRANSDUCER - PRESSUR	1
	039-0026-03	TRANSDUCER - PRESSUR	1
	AE8-1376	AE BULLETIN	1
943-0037-03 230V Pressure Based Fan Cycling Stand Alone Kit	543-0135-03	CONTROLLER - ELECT UN	1
	032-7050-00	CLIP	2
	529-0113-02	CABLE-SENSOR ASSM.	1
	529-0114-00	CABLE-SENSOR ASSM.	1
	039-0026-02	TRANSDUCER - PRESSUR	1
	039-0026-03	TRANSDUCER - PRESSUR	1
	AE8-1376	AE BULLETIN	1
962-0007-00 EUC Enclosure Kit	062-7048-01	BOX - ELECTRICAL	1
	005-7226-01	COVER - LID	1
	036-0275-00	FITTING - KNOCKOUT PLU	2
	100-0180-09	SCREW - HEX HD SELF TA	1

NOTES:

Safe-NET III™ TEMPERATURE AND DEFROST CONTROLLER

SAFE-NET III™ USER INSTRUCTIONS

Your refrigerated case uses a Hussmann Safe-NET™ III temperature and defrost controller to precisely maintain the temperature and prevent frost buildup on the cooling coil. LEDs indicate when the compressor or refrigeration is on, when the case is in a defrost cycle, if the temperature is outside the desired range, or if there is a sensor failure.

An adjustment knob allows the temperature to be set within the configured range and can power off the controller and compressor. Your controller has been custom-configured to provide the best temperature and defrost control for your chilled or frozen food.

The front of the controller has an adjustment knob and status LEDs. The back of the controller has connections for sensors and switched equipment.

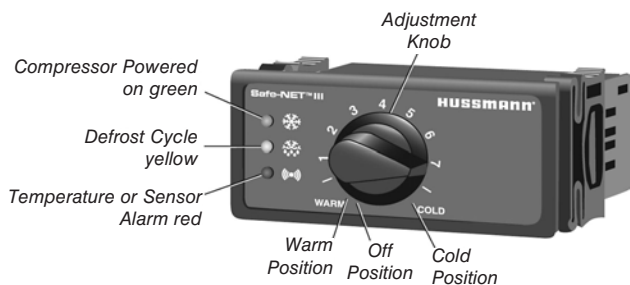

The Safe-NET III controller includes the following features and connections.

- **Adjustment knob:**
Adjusts the temperature setpoint.
Turn adjustment knob to OFF to turn off refrigeration system. Unplug merchandiser from power before servicing the unit.

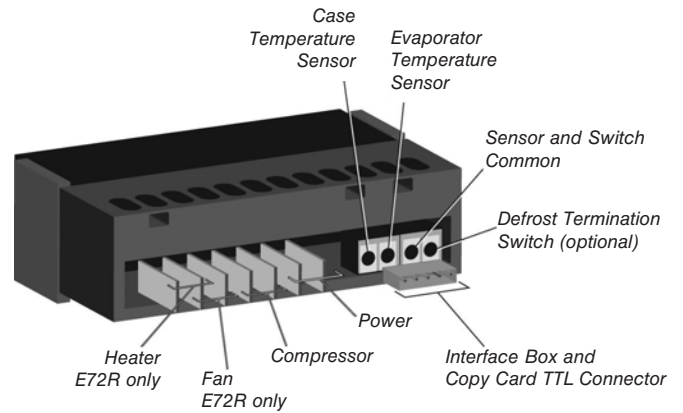

- **Controller LEDs:**
 - ❄️ **Compressor Powered On LED (green):**
Lights while the compressor is running or the refrigeration valve is open.
 - ❄️ **Defrost Cycle LED (yellow):**
Lights while the refrigeration coil is defrosting.
 - 🔊 **Temperature or Sensor Alarm (red):**
Lights if the temperature is too warm or too cold. Flashes if a sensor fails.
- **Rear connections:**
 - **Case temperature sensor:**
 - Typically senses the temperature of the air in the case.
Used by the controller to determine when to power on or power off the compressor or refrigeration.
 - **Evaporator temperature sensor:**
 - Senses the temperature of the refrigeration coil.
 - **Compressor or refrigeration relay:**
 - Switches on the compressor or refrigeration valve for cooling.

WARNING

The optional evaporator fan remains ON when the adjustment knob is in the OFF position.

DISPLAY

The display includes three red LEDs and two digits for temperature, defrost status, and error codes.

The three display LEDs are red; their behavior matches the LEDs on the controller.

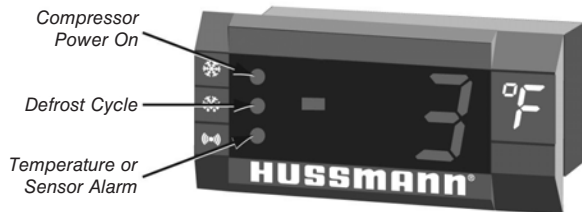

START-UP

1. Plug in the merchandiser.

! WARNING

The OFF Position does not disconnect line voltage to the case, refrigeration unit, fan, or heater.

2. Wait for the self check to complete. During the self check, each LED flashes for one second, then all LEDs turn on for two seconds. If the LEDs do not flash, make sure the adjustment knob is not in the Off position.
 - After the self check, all LEDs turn off until the compressor starts. **There may be a delay before the compressor starts**, if the red Temperature or Sensor Alarm LED stays on after the self check.
 - The green Compressor Powered On LED turns on when the compressor starts.

! WARNING

Product will be degraded and may spoil if allowed to sit in a non-refrigerated area.

NOTE: Do NOT load product until AFTER merchandiser operates for 24 hours and reaches desired operating temperature.

1. Apply power to the merchandiser. Wait for the self check to complete. During the self check, each LED flashes for one second and then all LEDs turn on for two seconds. If the LEDs do not flash, make sure the adjustment knob is not in the “OFF” position.

- 1A. The merchandiser temperature displays at startup. The initial defrost starts two hours later. The display will show “DF” at the start of defrost. This reading will remain displayed during defrost and until it times out, even though the refrigeration mode has been initiated.
(The green LED will be lit.)

2. The compressor will start after a 30 second delay once power is applied.
3. The compressor will continue to run until it reaches its cut-out temperature (Pulldown).
4. The refrigeration cycle will continue for the next subsequent scheduled defrost.
5. The above process will repeat (steps 3 and 4) until the power is interrupted.
6. If power stops, the process will start over at step 1, and the time to subsequent defrost will reset.
7. Medium temperature is the same except for a 30-minute time terminated defrost

Sequence of Operation DF5NX CF5X

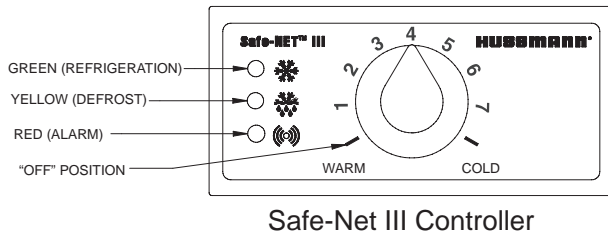
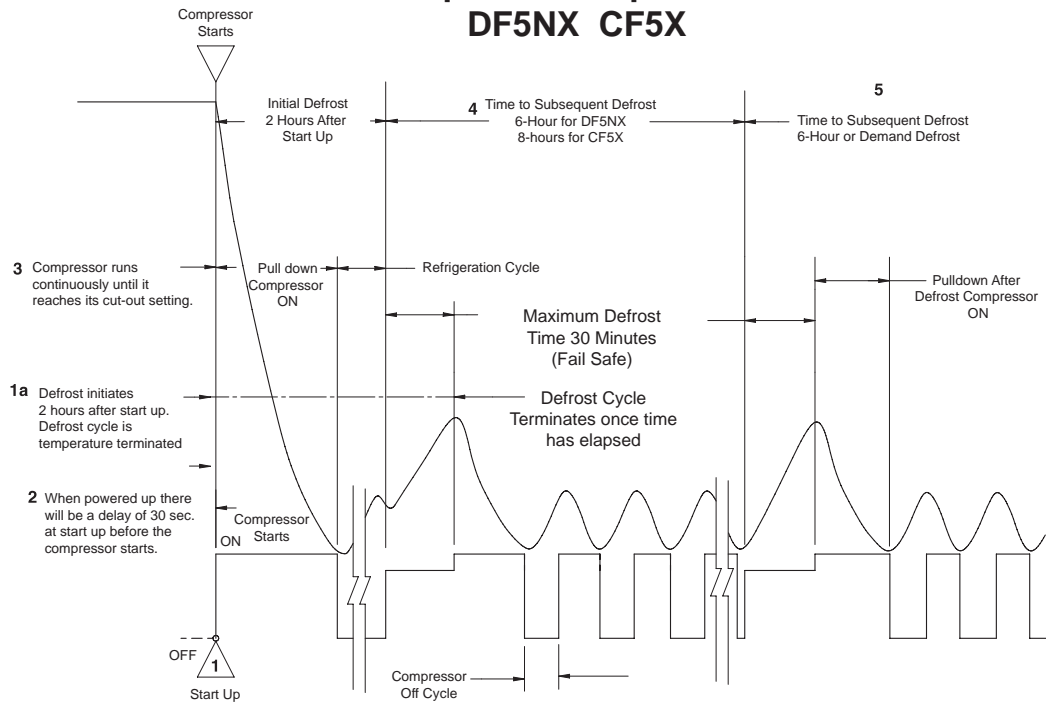

Safe-Net III Controller

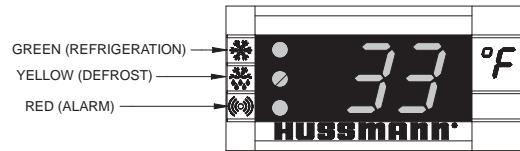

DISPLAY

1. Apply power to the case. Wait for the self check to complete. During the self check, each LED flashes for 1 second, and then all LEDs turn on for 2 seconds. If the LEDs do not flash, make sure the adjustment knob is not in the “OFF” position. The display will also be blank “OFF.” Upon power up, the display will show the case temperature. The initial defrost will occur 2 hours later. The display will show the “DF” at initiation of defrost. This reading will remain displayed during defrost and until it times out, even though the refrigeration mode has been initiated. (The green LED will be on.) The subsequent defrost will occur at 6-hour intervals, after initial defrost (4-defrost/day).
2. The compressor will start after a delay of “10” seconds after the power is applied.
3. The compressor will continue to run until it reaches its cutout temperature (pulldown).
4. The refrigeration cycle will continue until the next subsequent scheduled defrost.
5. The above process will repeat (Steps 3 and 4) until the power is interrupted.
6. If the power is interrupted, the process will start over at Step 1, and the time to subsequent defrost will reset.

TEMPERATURE ADJUSTMENT

Rotate the adjustment knob counter clockwise for a warmer setpoint or clockwise for a colder setpoint.

- While the temperature is being adjusted, the optional display shows the setpoint (cut out value). A few seconds after the temperature is set, the display reverts to showing the sensed temperature in the merchandiser.

ALARMS AND CODES

FLASHING TEMPERATURE OR SENSOR ALARM



LED, E1 OR E2

If the Temperature or Sensor Alarm LED (red) on the controller and display is flashing, a temperature sensor has failed. The display shows E2 if the evaporator sensor has failed.

If the merchandiser sensor fails, refrigeration will run continuously. Turn off, or repeat a duty cycle of a few minutes on and a few minutes off.

MANUAL DEFROST

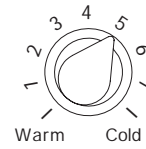

1. Note location of knob setting

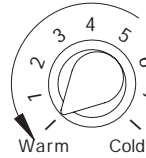

2. Rotate knob fully counterclockwise until it stops (full warm - "OFF" position)



3. After 10 seconds, but before 20 seconds, rotate knob fully clockwise until it stops (full cold position)

Note:

This procedure initiates a manual or forced defrost.

IMPORTANT: Return the control knob to its original setting (Step 1) once the manual defrost has been initiated.



HUSSMANN[®]

**To obtain warranty information
or other support, contact your
Hussmann representative.
Please include the model and
serial number of the product.**

Hussmann Corporation, Corporate Headquarters: Bridgeton, Missouri, U.S.A. 63044-2483 01 October 2012

Husmann Corporation

12999 St. Charles Rock Road

Bridgeton, MO 63044-2483

www.husmann.com