

HUSSMANN®



DOE 2017
Energy Efficiency
Compliant

VRL *Low Temperature Self Contained Glass Door Merchandisers with R290 Refrigerant*

WARNINGS:

If the information in these instructions are not followed exactly, a fire or explosion may result, causing property damage, personal injury or death.

Installation and service must be performed by a qualified installer or service agency.

**READ THE ENTIRE MANUAL BEFORE
INSTALLING OR USING THIS EQUIPMENT.**

The unit uses R-290 (propane) gas as the refrigerant. R-290 (propane) is flammable and heavier than air. It collects first in low areas but can be circulated by the fans. If propane gas is present or even suspected, do not allow untrained personnel to attempt to find the cause. The propane gas used in the unit has no odor. The lack of smell does not indicate a lack of escaped gas. If a leak is detected, immediately evacuate all persons from the store, and contact the local fire department to advise them that a propane leak has occurred. Do not let any persons back into the store until the qualified service technician has arrived and that technician advises that it is safe to return to the store. No open flames, cigarettes or other possible sources of ignition should be used inside or in the vicinity of the units.

**FAILURE TO ABIDE BY THIS WARNING COULD
RESULT IN AN EXPLOSION, DEATH, INJURY AND
PROPERTY DAMAGE.**

IMPORTANT

Keep in store for future reference!



Installation & Operation Manual

P/N 3034040_E

April 2019

*Spanish 3034045
French 3034044*



BEFORE YOU BEGIN

Read these instructions completely and carefully.



PERSONAL PROTECTION EQUIPMENT (PPE)

Personal Protection Equipment (PPE) is required whenever installing or servicing this equipment. Always wear safety glasses, gloves, protective boots or shoes, long pants, and a long-sleeve shirt.

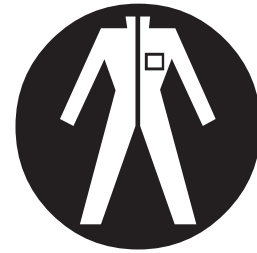
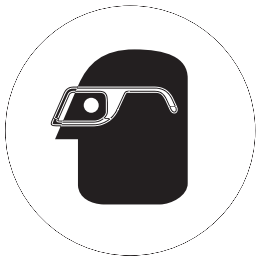

1. If the information in these instructions are not followed exactly, a fire or explosion may result, causing property damage, personal injury or death.
2. Installation and service must be performed by a qualified installer or service agency.
3. This unit is designed only for use with R-290 (propane) gas as the designated refrigerant.

THE REFRIGERANT LOOP IS SEALED. ONLY A QUALIFIED TECHNICIAN SHOULD ATTEMPT TO SERVICE!

- Propane is flammable and heavier than air.
- It collects first in the low areas but can be circulated by the fans.
- If R-290 (propane) is present or even suspected, do not allow untrained personnel to attempt to find the cause.
- The propane gas used in the unit has no odor.
- The lack of smell does not indicate a lack of escaped gas.
- If a leak is detected, immediately evacuate all persons from the store, and contact the local fire department to advise them that a propane leak has occurred.
- Do not let any persons back into the store until the qualified service technician has arrived and that technician advises that it is safe to return to the store.
- A hand-held propane leak detector (“sniffer”) shall be used before any repair and/or maintenance.
- No open flames, cigarettes or other possible sources of ignition should be used inside the building where the units are located until the qualified service technician and/or local fire department determines that all propane has been cleared from the area and from the refrigeration systems.
- Component parts are designed for propane and non-incendive and non-sparking. Component parts shall only be replaced with identical repair parts.

FAILURE TO ABIDE BY THIS WARNING COULD RESULT IN AN EXPLOSION, DEATH, INJURY AND PROPERTY DAMAGE.

ATTENTION

Merchandiser must operate for 24 hours
before loading product!

Regularly check merchandiser temperatures.

Do not break the cold chain. Keep products in
freezer before loading into merchandiser.

These merchandisers are designed
for only pre-frozen products.



IMPORTANT
KEEP IN STORE FOR FUTURE REFERENCE
Quality that sets industry standards!

12999 St. Charles Rock Road • Bridgeton, MO 63044-2483

U.S. & Canada 1-800-922-1919 • Mexico 1-800-890-2900

www.hussmann.com

© 2019 Hussmann Corporation

4 INSTALLATION

REVISION HISTORY

REVISION E

Added recovering refrigerant steps

REVISION D

Removed Fan Key Page; Updated parts list and diagrams; added California Warning.

REVISION C

Changed Added VRL 1-door cases
Changed info about door torque.

REVISION B

Changed NEMA Plug..... Page 13



ORIGINAL ISSUE — JULY 2017

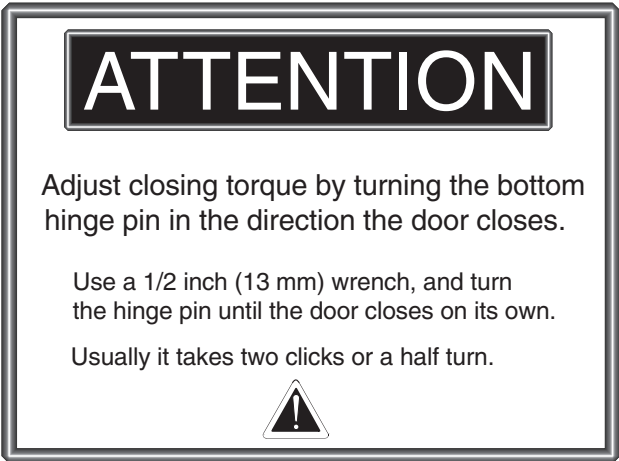

This warning does not mean that Hussmann products will cause cancer or reproductive harm, or is in violation of any product-safety standards or requirements. As clarified by the California State government, Proposition 65 can be considered more of a ‘right to know’ law than a pure product safety law. When used as designed, Hussmann believes that our products are not harmful. We provide the Proposition 65 warning to stay in compliance with California State law. It is your responsibility to provide accurate Proposition 65 warning labels to your customers when necessary. For more information on Proposition 65, please visit the California State government website.



ANSI Z535.5 DEFINITIONS

-  • **DANGER** – Indicate[s] a hazardous situation which, if not avoided, will result in death or serious injury.
-  • **WARNING** – Indicate[s] a hazardous situation which, if not avoided, could result in death or serious injury.
-  • **CAUTION** – Indicate[s] a hazardous situation which, if not avoided, could result in minor or moderate injury.
- **NOTICE** – *Not related to personal injury* – Indicates[s] situations, which if not avoided, could result in damage to equipment.



INSTALLATION

NSF LISTING

These merchandisers are manufactured to meet ANSI / UL 471 standard requirements for safety. Proper installation is required to maintain this listing. Near the serial plate, each case carries a label identifying the type of conditions for which the merchandiser was tested.

ANSI/NSF-7 Type I – Display Refrigerator / Freezer Intended for 75°F / 55% RH Ambient Application

ANSI/NSF-7 Type II – Display Refrigerator / Freezer Intended for 80°F / 55% RH Ambient Application

ANSI/NSF-7 – Display Refrigerator Intended for Bulk Produce

FEDERAL / STATE REGULATION

These merchandisers, at the time they are manufactured, meet all federal and state / provincial regulations.

HUSSMANN PRODUCT CONTROL

The serial number and shipping date of all equipment is recorded in Hussmann's files for warranty and replacement part purposes. All correspondence pertaining to warranty or parts ordering must include the serial number of each piece of equipment involved. This is to ensure the customer is provided with the correct parts.

SHIPPING DAMAGE

All equipment should be thoroughly examined for shipping damage before and during unloading. This equipment has been carefully inspected at our factory. Any claim for loss or damage must be made to the carrier. The carrier will provide any necessary inspection reports and/or claim forms.

HUSSMANN CORPORATION • BRIDGETON, MO 63044-2483 U.S.A.

Apparent Loss or Damage

If there is an obvious loss or damage, it must be noted on the freight bill or express receipt and signed by the carrier's agent; otherwise, carrier may refuse claim.

Concealed Loss or Damage

When loss or damage is not apparent until after equipment is uncrated, retain all packing materials and submit a written response to the carrier for inspection within 15 days.

LOCATION

These merchandisers are designed for displaying products in air conditioned stores where temperature is maintained at or below the ANSI / NSF-7 specified level and relative humidity is maintained at or below 55%.

<p>Recommended operating ambient temperature is between 60°F (15.6°C) to 80°F (26.7°C). Maximum relative humidity is 55%.</p>
--

Placing refrigerated merchandisers in direct sunlight, near hot tables or near other heat sources could impair their efficiency. Like other merchandisers, these merchandisers are sensitive to air disturbances. Air currents passing around merchandisers will seriously impair their operation. Do NOT allow air conditioning, electric fans, open doors or windows, etc. to create air currents around the merchandiser. *VRL units in take air and exhaust air through the front of the case, and require no clearance space on top, at back or either side.*

6 INSTALLATION

SELF CONTAINED (LOCATION)

Product should always be maintained at proper temperature. This means that from the time the product is received, through storage, preparation and display, the temperature of the product must be controlled to maximize the life of the product.

BE SURE TO POSITION SELF CONTAINED MERCHANDISERS PROPERLY.

VRL models have vented base panels to allow air circulation through the condensing unit.

Allow for a minimum 36 in. clearance in the front. Blocking or restricting air flow will adversely affect performance and may damage the refrigeration system.

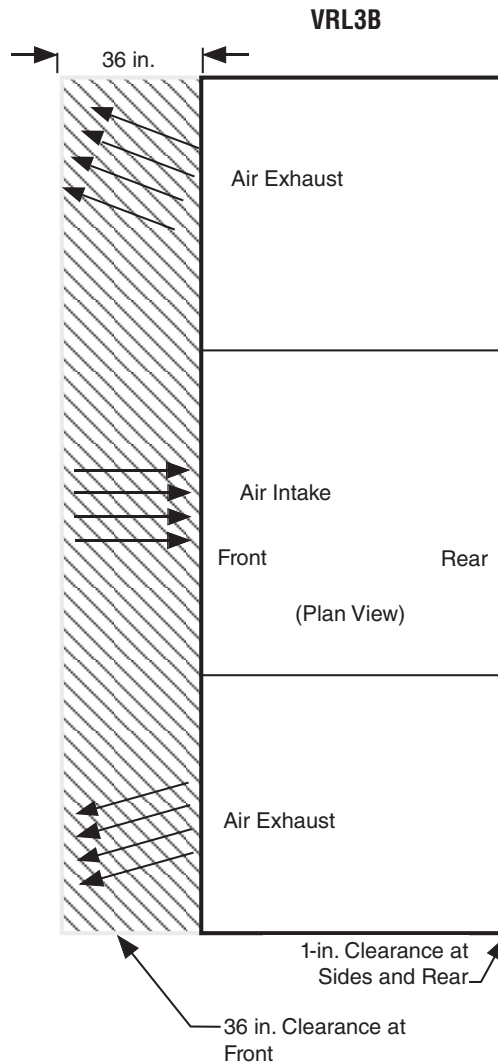
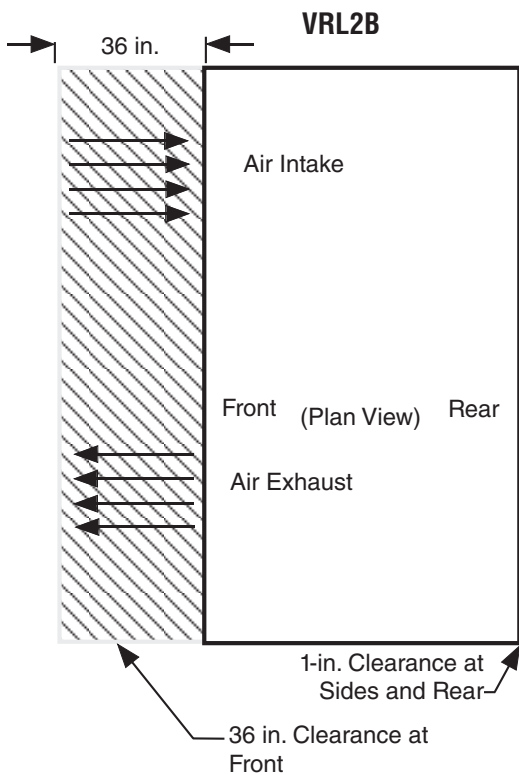
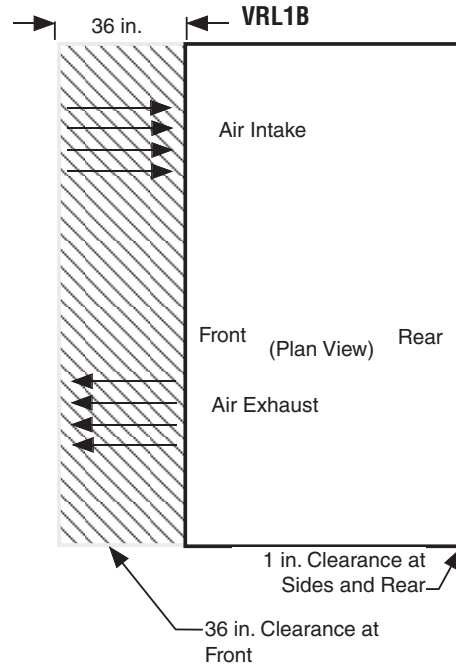

UNLOADING

Unloading from Trailer:

Lever Bar (also known as a Mule, Johnson Bar, J-Bar, Lever Dolly, or Pry Lever)

Move the merchandiser as close as possible to its permanent location and remove all packaging. Check for damage before discarding packaging. Remove all separately packed accessories such as kits and shelves.

Improper handling may cause damage to the merchandiser when unloading. To avoid damage:

1. Do not drag the merchandiser out of the trailer. Use a Johnson bar (Mule).
2. Use a forklift or dolly to remove the merchandiser from the trailer.



Each merchandiser is shipped on a skid to protect the merchandiser's base and to make positioning the case easier.

Remove the top of the crate and detach walls from each other (if applicable). Lift crate from the skid. Unscrew the case from the skid. The merchandiser can now be lifted off the crate skid. **Lift only at base of skid!** Remove any braces and/or skids attached (blanket wrapped merchandiser may have skids).

DO NOT TILT MERCHANDISER ON ITS SIDE OR END WHEN REMOVING SKID.

Once the skid is removed, the merchandiser must be lifted —NOT PUSHED— to reposition. To remove the skid, remove screws attaching skid to the merchandiser.

Check floor where merchandisers are to be set to if it is a level area. Determine the highest part of the floor.

EXTERIOR LOADING

Do NOT walk on top of the merchandiser or damage to the merchandisers and serious personal injury could occur.

MERCHANDISERS ARE NOT STRUCTURALLY DESIGNED TO SUPPORT EXCESSIVE EXTERNAL LOADING such as the weight of a person. Do not place heavy objects on the merchandiser.

SHIPPING SKID

MODEL DESCRIPTION

VRL merchandisers are low temperature self-contained cabinets, designed for pre-packaged frozen food or products that require frozen temperatures for conservation.

Design Features

- Contemporary styling places maximum attention on merchandising
- All VRL merchandisers have the same access panel design for commonality between merchandisers
- Self-closing Innovator doors. Positive seal, torsion type closure system
- Triple-pane thermal insulated glass door assemblies
- Magnetic door gaskets of one-piece construction, removable without tools for ease of cleaning
- Merchandiser can be placed against wall - no air gap is required behind the case
- Digital display in center of case air grill

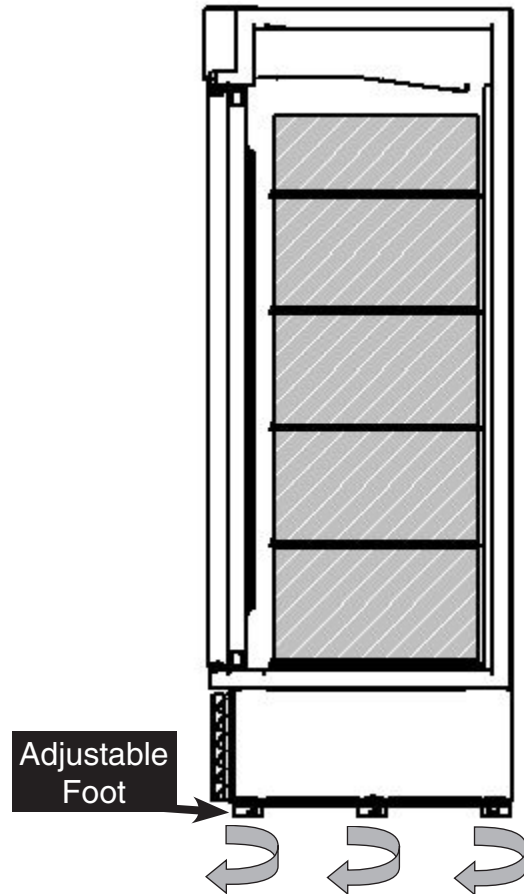

CABINET LEVELING

This merchandiser must be installed level (from back to front, and side to side) to allow maximum draining of the condensate water as well as proper door alignment and operation. Choose a level area to install case.

VRL2B and VRL3B also have an adjustable foot at center front and back. Turn the foot levelers clockwise to add length to each foot for leveling.

When optional casters are used, screw them tight to the merchandiser base. Once in final position, lock each caster.

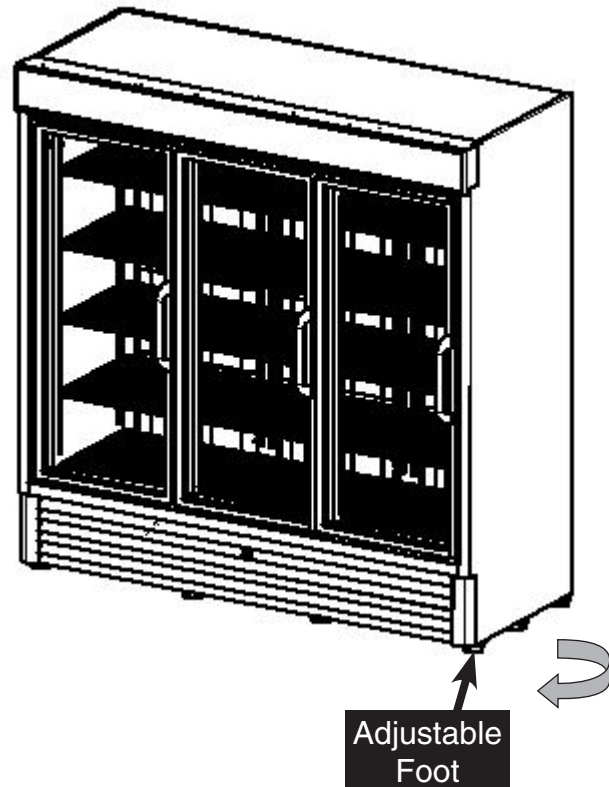

SHELF INSTALLATION

After the cabinet is leveled, the shelves may be installed. Wire shelves are adjustable. Shelf spacing can be adjusted by positioning the shelf clips according to individual loading requirements.

VRL merchandisers have four movable wire shelves and one bottom wire shelf, per door.

LAMPS

This merchandiser has a light switch inside of the left door frame. The switch controls the display lighting and interior lighting.



Light Switch

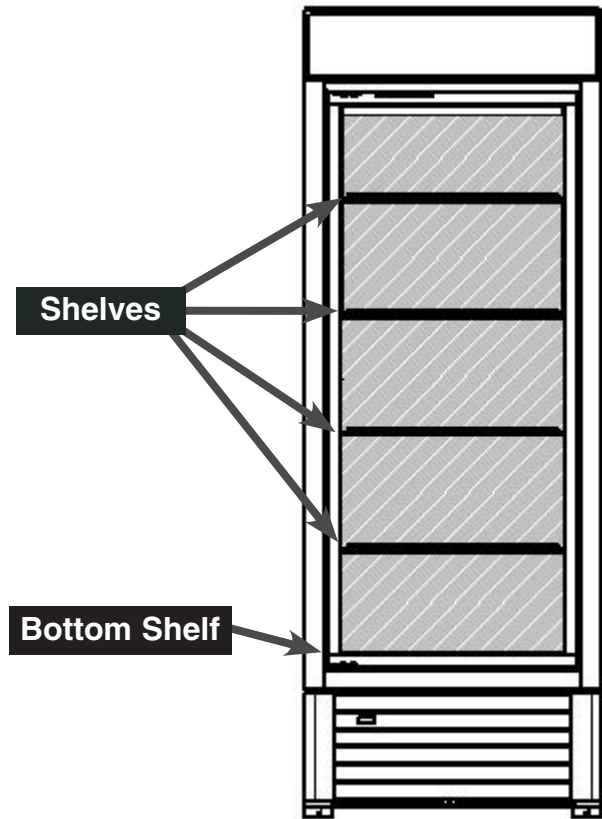

STOCKING

Product should NOT be placed in case until merchandiser is at proper operating temperature. **The VRL merchandisers must remain in operation for at least 24 hours before product may be loaded into case cabinet.**

Proper rotation of product during stocking is necessary to prevent product loss. Always bring the oldest product to the front and set the newest to the back.

AIR EXHAUST AND RETURN GRILLE MUST REMAIN OPEN AND FREE OF OBSTRUCTION AT ALL TIMES.

Do not allow product, packages, signs, etc. to block air exhaust or return grille. Do not use non-approved shelving, baskets, display racks, or any accessory that could hamper air curtain performance. **DO NOT STOCK PRODUCT IN THE TOP FOUR INCHES OF VRL CASES BECAUSE PRODUCT WILL BLOCK THE COLD AIR FLOW.**

LOAD LIMITS

Product must be within designated load limit to ensure proper refrigeration and air curtain performance.

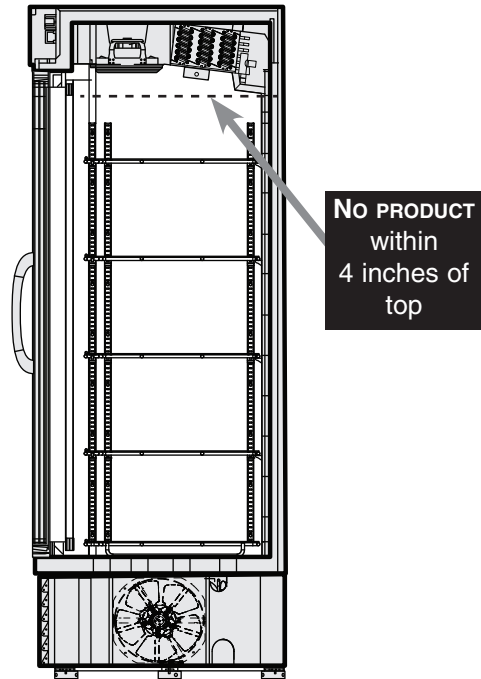

Load Limit for VRL Merchandisers

At no time should product be stocked:

- Beyond the front and rear of the shelves
- Near the air supply duct located at the top rear of case
- Near or covering the evaporation fan grilles
- Within four inches of the top of the cabinet (This space must be free of product and other materials.)

DO NOT LOAD CASE WITH WARM PRODUCT.

Hussmann Self-Contained Refrigeration Equipment Start Up Check List

Please note that failure to follow this start-up document may void your factory warranty

Step	Startup Activity	Check
1	Locate, read and maintain install/operation manual in a safe place for future reference.	<input type="checkbox"/>
2	Examine unit. Confirm there is NO damage or concealed damage.	<input type="checkbox"/>
3	Level the unit, side to side and front to rear.	<input type="checkbox"/>
4	Remove all shipping brackets/compressor straps/bolts etc.	<input type="checkbox"/>
5	Unit must be run on a dedicated electrical circuit without the use of an extension cord.	<input type="checkbox"/>
6	Ensure that the proper electrical requirements for the equipment are supplied.	<input type="checkbox"/>
7	Verify field electrical connections are tight.	<input type="checkbox"/>
8	Verify all electrical wiring is secured and clear of any sharp edges or hot lines.	<input type="checkbox"/>
9	Verify the condensate drain line is properly trapped and pitched.	<input type="checkbox"/>
10	Verify all required clearances on the sides and back of unit.	<input type="checkbox"/>
11	Verify there are no air disturbances external to the unit. Heat and air registers, fans, and doors etc.	<input type="checkbox"/>
<p>Advise owner/operator that merchandiser must operate at temperature for 24 hrs prior to loading with product.</p>		

Form HSCW01 Rev. 30MAY12 P/N 0525209_B

LEGAL DISCLAIMER:

Hussmann shall not be liable for any repair or replacements made without the written consent of Hussmann, or when the product is installed or operated in a manner contrary to the printed instructions covering installation and service which accompanied such product.

NOTES:

ELECTRICAL / REFRIGERATION

PLUG

The plug cord is 9ft long and is located on the right hand rear of the merchandiser. Disconnect power before servicing. VRL merchandisers require a dedicated electrical circuit with ground. 12AWG is the minimum sized acceptable wire.



WARNING

**Merchandiser must be grounded.
Do not remove the power supply cord ground.**

- The VRL1B requires a dedicated 15 AMP/208-230V circuit with a grounded wall receptacle (NEMA L6-15R).
- The VRL2B requires a dedicated 15 AMP/208-230V circuit with a grounded wall receptacle (NEMA L6-15R).
- The VRL3B requires a dedicated 20 AMP/208-230V circuit with a grounded wall receptacle (NEMA L6-20R).
- Always use a dedicated circuit with the amperage stated on the unit.
- Plug into an outlet designed for the plug.
- Do not overload the circuit.
- Do not use long or thin extension cords. Never use adapters.
- If in doubt, call an electrician.

ALWAYS CHECK THE SERIAL PLATE FOR COMPONENT AMPERES

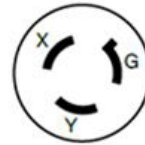

NEMA L6-15P
VRL1B
VRL2B

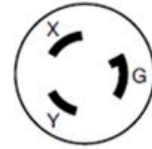

NEMA L6-20P
VRL3B



CAUTION

Risk of Electric Shock. If cord or plug becomes damaged, replace only with a cord and plug of the same type.

Nominal Voltage	Minimum Voltage	Maximum Voltage
208-230	188	253



WARNING

— LOCK OUT / TAG OUT —

To avoid serious injury or death from electrical shock, always disconnect the electrical power at the main disconnect when servicing or replacing any electrical component. This includes, but is not limited to, such items as doors, lights, fans, heaters, and thermostats.

Before Beginning Any Service or Repair:

Use a hand-held propane leak detector (“sniffer”) to ensure no propane is present in the immediate area, the inside of the display case and the inside of the refrigeration system. R-290 is an odorless refrigerant. Keep the area clear of all customers and non-essential or unauthorized personnel.

Verify that all repair parts are identical models to the ones they are replacing. Do not substitute parts such as motors, switches, relays, heaters, compressors, power supplies or solenoids. Failure to do so can result in an explosion, death, injury and property damage. Parts used on hydrocarbon cases must meet specific UL certification for non-incendive or non-sparking components. Use only Hussmann approved parts approved through the Hussmann Performance Parts Website. <https://parts.hussmann.com/>

Brazing must not begin before all propane has been cleared from the immediate area — the inside of the displays case and the inside of the refrigeration system.



WARNING

Only Hussmann or factory trained technicians should service or repair this R-290 (propane) equipment.

Failure to follow instructions can result in an explosion, death, injury and property damage.

If a leak is detected, follow store safety procedures. It is the store’s responsibility to have a written safety procedure in place. The safety procedure must comply with all applicable codes such as local fire department’s codes.

At minimum, the following actions are required:

- Immediately evacuate all persons from the store, and contact the local fire department to advise them that a propane leak has occurred.
- Call Hussmann and/or a qualified service agent and inform them that a propane sensor has detected the presence of propane.
- Do not let any persons back into the store until the qualified service technician has arrived and that technician advises that it is safe to return to the store.

- The propane gas used in the unit has no odor. The lack of smell does not indicate a lack of escaped gas.
- A hand-held propane leak detector (“sniffer”) should be used before any repair and/or maintenance is attempted. All repair parts must be identical models to the ones they are replacing.
- No open flames, cigarettes or other possible sources of ignition should be used inside the building where the units are located until the qualified service technician and/or local fire department determines that all propane has been cleared from the area and from the refrigeration systems.

REPLACING REFRIGERATION SYSTEM COMPONENTS

DANGER

Only Hussmann service technicians or technicians qualified to handle R-290 (propane) refrigerant should service or repair this R-290 (propane) equipment. Failure to follow instructions can result in an explosion, death, injury and property damage.

NOTICE

For VRL merchandisers with a serial number starting with MY19C or earlier, there may be a solenoid valve in place on the liquid line between the condenser coil and the filter drier. This is a normally closed solenoid. When the unit is deenergized, refrigerant can become trapped between the compressor and this valve. When removing the refrigerant from the system, line tap valves must be placed between the compressor and this solenoid valve as well as on the low side of the system.

STEPS TO RECOVER REFRIGERANT

1. Make sure you are in a well ventilated area before making any service or repair to the refrigeration system.
2. Disconnect all power sources from the system. Some systems may have more than one plug or power supply.
3. Tap system with line tap valves, attaching gauges to the high and low sides of the system.



**refrigeration
line tapping
valve**

4. Connect hose to an evacuated recovery tank. Open refrigeration gauges and recovery tank.



5. With the suction valve in vacuum, the refrigerant will be recovered into the recovery tank.
6. Once recovered, close the tank valve and remove the gauge from the tank and connect nitrogen tank to the system to purge it with nitrogen.
7. Pull vacuum to a minimum of 200 microns or lower.

CHARGING

A calibrated scale with +/-2 gram accuracy must be used to charge the system. The charge amount is shown on the serial plate. Only R-290 grade refrigerant can be used. Standard propane does not meet the purity/moisture content of R-290, and therefore cannot be used to charge cases.

No gas charge adjustments are allowed. When connecting hoses between the refrigeration system, manifold gauges, and refrigerant cylinder, ensure that the connections are secure and there are no potential sources of ignition nearby. Ensure that contamination of different refrigerants does not occur when using charging equipment.

Use dedicated hoses to service R-290 (propane) refrigeration systems. Hoses or lines should be as short as possible to minimize the amount of refrigerant contained in them.

Ensure that the refrigeration system is properly grounded prior to charging the system with refrigerant, to avoid the potential for static build-up.

WARNING

Component parts shall be replaced with like components, and servicing shall be done by factory authorized service personnel only, so as to minimize the risk of possible ignition due to incorrect parts or improper service.

Extreme care must be taken not to overfill the refrigeration system. After charging, carefully disconnect the hoses, attempting to minimize the quantity of refrigerant released. Further leak check the service ports, hoses, refrigerant tanks. The service ports shall be checked for leaks using a hydrocarbon leak detector with a sensitivity of 3 grams/year (0.106 Oz/year) leak rate.

Thoroughly leak check the service ports. If no leak is present, use a pinch-off tool to close the ends of the service tubes before brazing them shut. If a Schrader valve is used on the compressor service tube, it must be removed and the previous steps followed in order to braze the service tube shut.

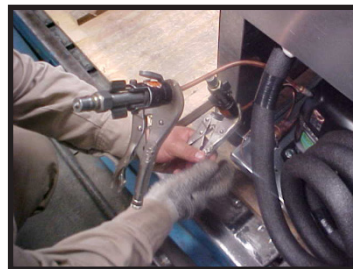

Typical Sensor to Control Configuration

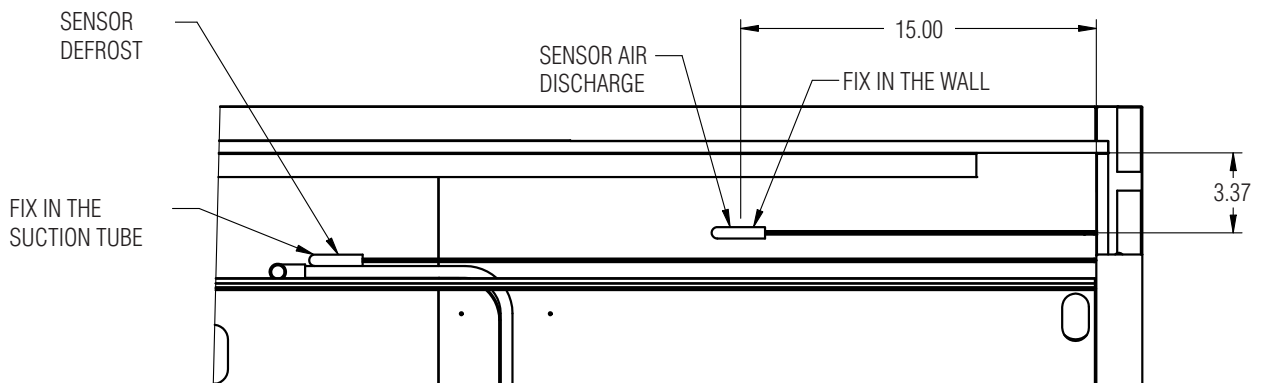
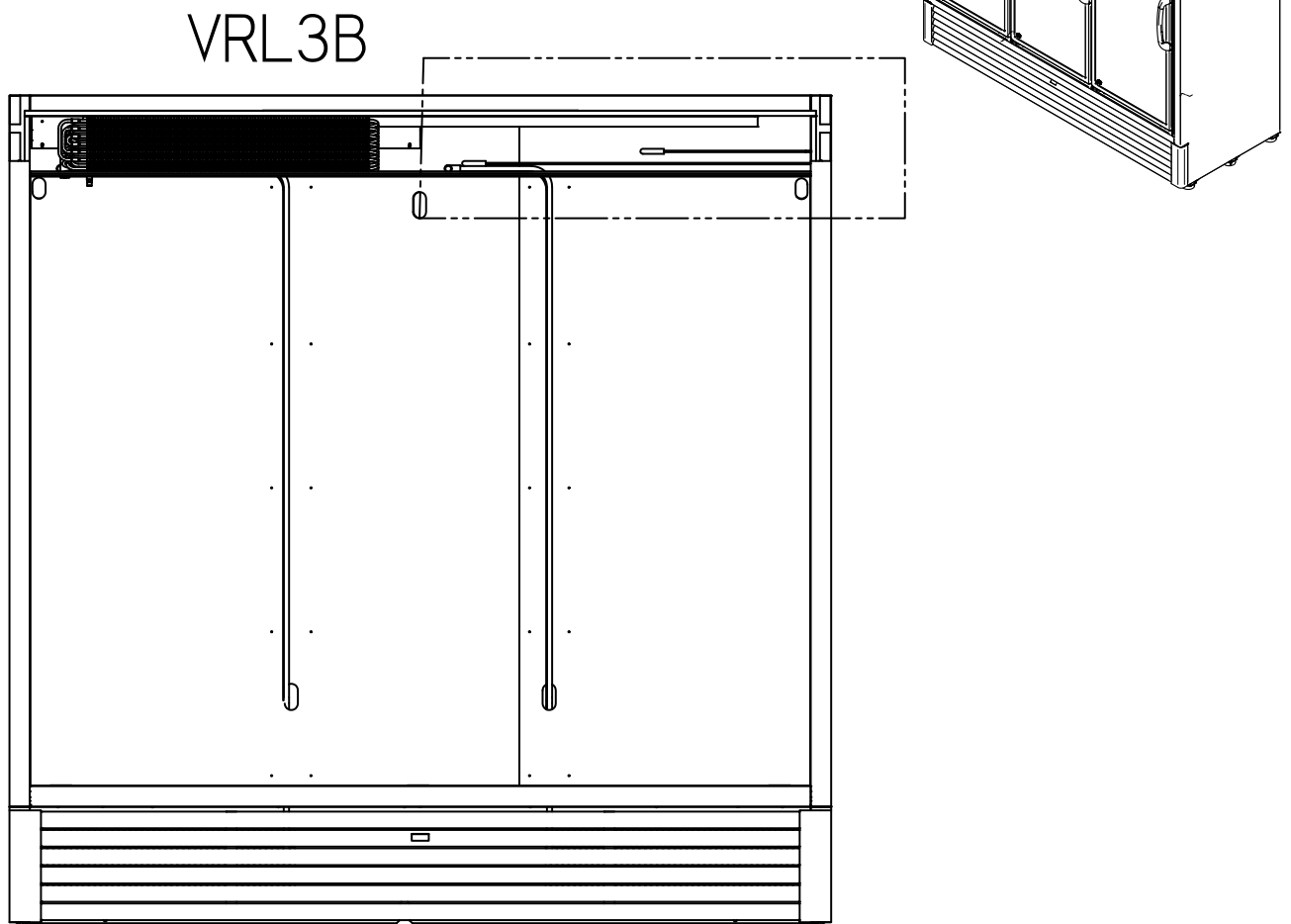

CONTROLLER

Hussmann Controller Operation RTN

1. Plug the merchandiser plug into its receptacle.
 - a. The controller display will illuminate.
 - b. The interior light will illuminate.
2. After the control preprogrammed time delay of up to 6 minutes, the compressor and evaporator fan(s) will start if the control is calling for cooling.
3. The control will cycle the compressor but may also cycle evaporator fan(s) on and off determined by the Set-Point and Differential temperatures.
 - a. The Set-Point is the adjustable preprogrammed temperature.
 - b. The Differential is the non-adjustable pre programmed temperature.
 - c. The Control is designed to read and display a cabinet temperature not a product temperature.

Taking as an example a VRL case, freezer. If the Set-Point is -12°F and the Differential is 9°F: (Set-Point) -12°F + 9 (Differential) = -3°F. The compressor and evaporator fan(s) will cycle off -12°F and back on at -3°F.

Main Features:

- Panel-mounted
- Energy saving algorithms and optimised defrost control
- 8 preloaded applications
- Defrost at single / double evaporator
- Frame Heater
- Local network auto-configuration
- Direct load connection (up to 2 HP)
- Supply voltage control LVD
- Presence of an open collector output

This cabinet temperature may reflect the refrigeration cycle of the Set-Point and it's Differential. The most accurate temperature on a cabinets operation is to verify the product temperature.

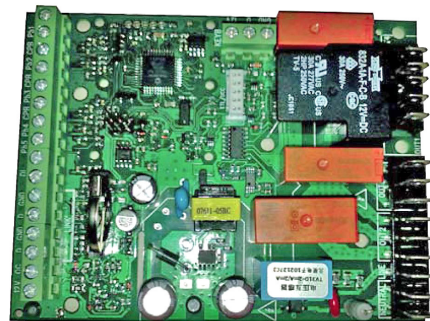

KDEPLUS BUTTONS

The KDEPlus keyboard has 4 keys, as shown in the illustration:



Key Functions:

- 2 ON/OFF regulators for HOT/COLD
- Single defrost and double evaporator
(heatings, modulated heaters, reverse cycle, hot gas)
- Evaporator fans and condenser fans
- Frame Heater
- AUX
- Light
- Door switch
- ON /OFF
- Deep cooling cycle
- Day / Night
- Diagnostics
- “Easy Map” programming
- Programmable inputs/outputs
- LINK2 local area network
- RS485 communication protocol: Modbus
- Compatible with Device Manager (DM)
- Compatible with Unicard and Multi-function key

TECHNICAL DATA**STANDBY or ESC**

Classification:	electronic automatic control (not safety) device for incorporation
Mounting:	panel mounting
Type of action:	1.B
Pollution class:	2
Material class:	IIIa
Overtoltage category:	II
Nominal pulse voltage:	2500V
Temperature:	Use: -5 ... +55°C - Storage: -30 ... +85°C
Power supply:	SMPS 100-240Va ±10% 50/60 Hz
Power consumption:	5.5W max
Fire resistance category:	D
Software class:	A
RTC battery life:	In absence of external power, the clock battery will last 3 years.

FURTHER INFORMATION

INPUT CHARACTERISTICS

Measurement range:	NTC: -50.0°C ... +110°C; PTC: -55.0°C ... +150°C; PT1000: -60.0°C ... +150°C (on 3-digit display with +/- sign)
Accuracy:	±1.0° for temperatures below -30°C ±0.5° for temperatures between -30°C and +25°C ±1.0° for temperatures above +25°C
Resolution:	1 or 0.1°C
Buzzer:	NO
Analogue/Digital Inputs:	5 configurable NTC/PTC/PT1000/DI inputs 1 multi-function, voltage-free digital input (D.I.)

OUTPUT CHARACTERISTICS

Digital Outputs:	OUT1: 1 SPST relay: 2HP max 240V~
	OUT2: 1 SPDT relay: 1HP max 250V~
	OUT3: 1 SPDT relay: 8(4)A max 250V~
	OUT4: 1 SPST relay: 8(4)A max 250V~
OC (Open Collector) Output:	OC: 1 multifunctional output: 12V \approx 20mA

MECHANICAL CHARACTERISTICS

Dimensions:	121x92 mm
Terminals:	faston and screw for wires with cross-section of 2.5mm ²
Connectors:	TTL for Unicard / Device Manager connection (via DMI)
Humidity:	Usage / Storage: 10...90% RH (non-condensing)

REGULATIONS

Electromagnetic compatibility:	The device complies with Directive 2004/108/EC
Safety:	The device complies with Directive 2006/95/EC
Food Safety:	The device complies with standard EN13485 as follows: <ul style="list-style-type: none"> • Suitable for storage. • Application: air. • Climate range A • measurement class 1 in the range from -25°C to 15°C (*)

(* with Eliwell probes only)

NOTE: The technical specifications stated in this document regarding measurement (range, accuracy, resolution, etc.) r the instrument alone and not to any accessories provided, such as the probes. This means, for example, that the error introduced by the probe must be added to the error of the instrument.

CONNECTIONS

TERMINALS

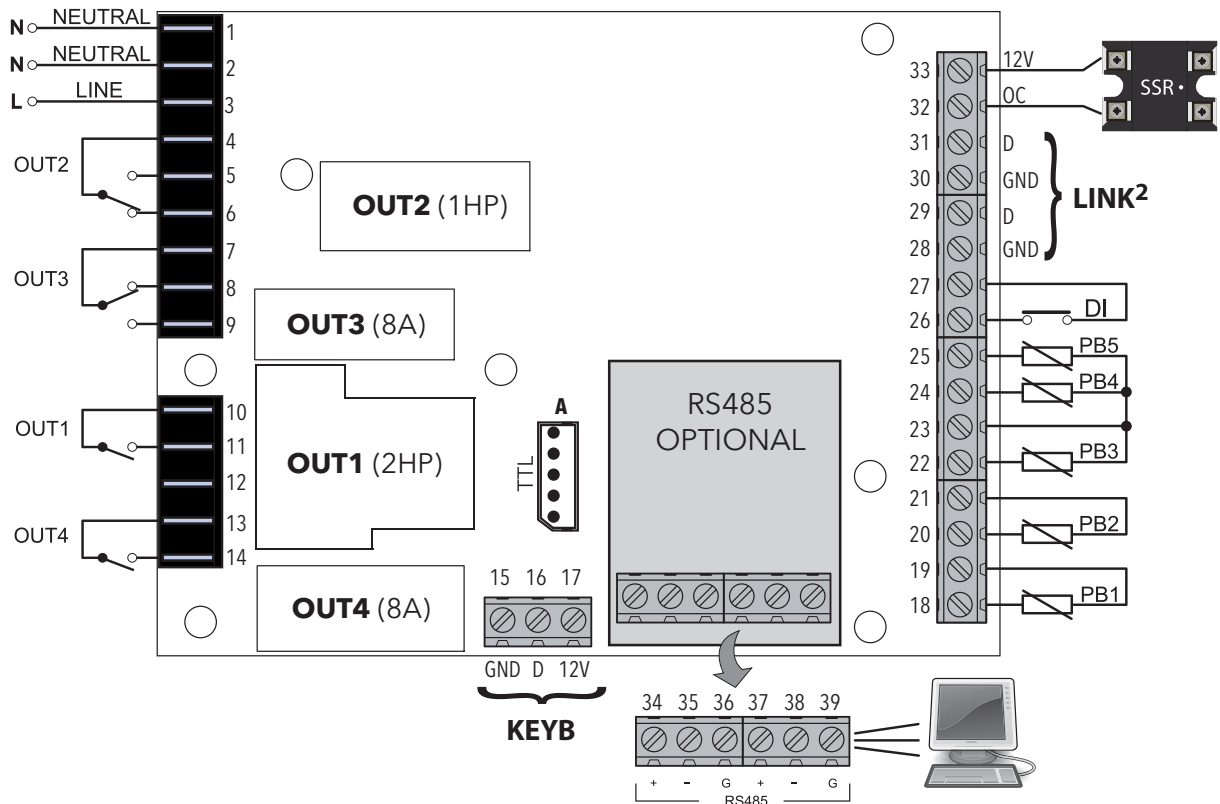

* **N.B.:** analogue inputs PB1...PB5 can also be configured as Digital Inputs DI.

TERMINALS	
1-2	NEUTRAL. These are power supply terminals.
3	LINE. These are power supply terminals.
4	OUT2 Shared Terminal
5	N.O. OUT2
6	N.C. OUT2
7	OUT3 Shared Terminal
8	N.C. OUT3
9	N.O. OUT3
10	OUT1 Shared Terminal
11	N.O. OUT1
12	Not Used
13	OUT4 Shared Terminal
14	N.O. OUT4
15-16-17	Connection to KDEPlus or KDWPlus external keyboard or ECPlus echo module.
19-18	PB1 probe connection.
21-20	PB2 probe connection.
23-22	PB3 probe connection.
23-24	PB4 probe connection.
23-25	PB5 probe connection.
27-26	Digital input (DI).
28-29	LINK ² . Connection 1 - local area network.
30-31	LINK ² . Connection 2 - local area network.
32-33	Open Collector Output (OC).
A	TTL Unicard/DMI/Multi Function Key connection
34-35-36	RS485. Connection 1 - Supervision Gateway.
37-38-39	RS485. Connection 2 - Supervision Gateway.







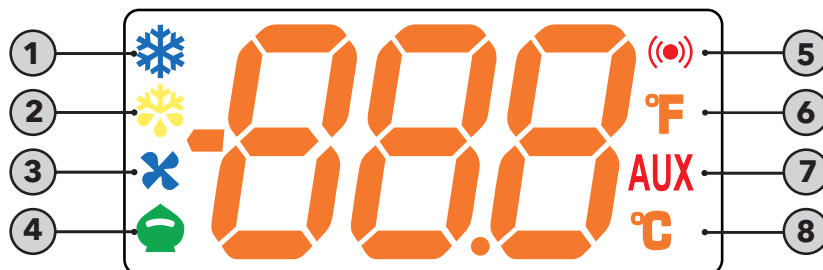

LED

RTN400 family controllers will also function even if a keyboard has not been connected.

With **KDEPlus** or **KDWPlus** keyboards (which are the same and guarantee the same functions), the display will be as follows:



Meaning of LEDs:

No	Icon	LED	Operation	Meaning
1		Compressor	Permanently on	compressor on
			Blinking	Delay, protection or start-up blocked
			OFF	otherwise
2		Defrost	Permanently on	Defrost active
			Blinking	Activated manually or from Digital Input
			OFF	otherwise
3		Fans	Permanently on	Fans active
			OFF	otherwise
4		Reduced SET / Economy	Permanently on	Energy Saving active
			Blinking	Reduced setpoint active
			OFF	otherwise
5		Alarm	Permanently on	alarm active
			Blinking	Alarm acknowledged
			OFF	otherwise
6		°F readout	Permanently on	°F setting (dro = 1)
			OFF	otherwise
7		AUX	Permanently on	Aux output active and/or light on
			Blinking	Deep cooling on
			OFF	otherwise
8		°C readout	Permanently on	°C setting (dro = 0)
			OFF	otherwise

N.B.: When the instrument is powered on it performs a lamp test, during which time the display and LEDs will flash for several seconds to check that they all function correctly.

KDEPLUS BUTTONS

The **KDEPlus** keyboard has 4 keys, as shown in the illustration:







Each key has a different function depending on whether it is:

- Pressed and released
- Pressed for at least 5 seconds
- Pressed and held at start-up
- Pressed in combination with another key.

KEYS

The following table summarizes the function of each key:

No	Key	Action		
		Pressed and released	Press for at least 5 secs	Start-up
1		<ul style="list-style-type: none"> • Scrolls through menu items • Decreases values 	Activates the Manual Defrost function (from outside menus).	---
2		<ul style="list-style-type: none"> • Scrolls through menu items • Decreases values 	Function can be configured by the user (from outside menus). (see parameter H32)	---
3		<ul style="list-style-type: none"> • Returns to the previous menu level • Confirms parameter value 	Activates the Stand-by function (from outside menus).	---
4		<ul style="list-style-type: none"> • Displays any alarms (if active) • Opens Machine Status menu • Confirms commands 	Opens the Programming Menu (User and Installer parameters)	When pressed during start-up it enables the user to select the application to be loaded.

SETPOINT: SETTING AND EDIT LOCK

To display the Setpoint value, press the **set** key to enter the "Machine Status" menu, then press the **set** key again when the "SEt" label is displayed.

The Setpoint value appears on the display. To change the Setpoint value, press the **UP** and **DOWN** keys within 15 seconds. Press **set** to confirm the modification.

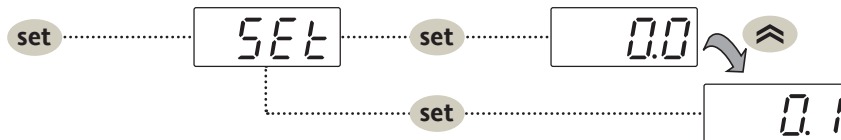

It is possible to disable the keypad on this device.

The keypad can be locked by programming the "LOC" parameter appropriately.

With the keypad locked, you can still access the "Machine Status" menu by pressing **set** to display the Setpoint, but you cannot edit it. To disable the keypad lock, repeat the locking procedure.

DISPLAY PROBES VALUE

To display the value read by probes connected to the device, press the **set** key and enter the "Machine Status" menu, then press the key again when one of the probe-related labels "Pb1...Pb5" press the **set** key again. The value measured by the associated probe will appear on the display.

NOTE: The displayed value is read-only and cannot be modified.

KDEPLUS BUTTONS

The **KDEPlus** keyboard has 4 keys, as shown in the illustration:



KEY-ACTIVATED FUNCTIONS

All models have the **UP** key set to enable the "Manual Defrost" function.

The **DOWN** and **ESC** keys can also be set to activate any other function required by the user.

The parameters for configuring the two keys are:

- **H11** = DOWN key configuration
- **H33** = ESC key configuration

The values that can be set apply to both keys and the functions that can be activated are:

H32/H33 value	Function to enable
0	disabled
1	defrost
2	reduced set
3	Light
4	Energy saving
5	AUX
6	Stand-by
7	Deep cooling cycle
8	Start/end defrost

MAINTENANCE

WARNING

To reduce the risk of fire, electrical shock or injury when cleaning this merchandiser:

- **Unplug the merchandiser before cleaning;**
- **Keep all liquids away from electrical and electronic components;**
- **Do not use any mechanical device or other means to speed the defrost process, except as recommended by the manufacturer.**

CARE AND CLEANING

Long life and satisfactory performance of any equipment is dependent upon the care it receives. To ensure long life, proper sanitation and minimum maintenance costs, this unit should be thoroughly cleaned, all debris removed and the interiors washed down. Cleaning often will control or eliminate odor buildup. Frequency of cleaning is dependent on usage and local health requirements.

WARNING

Do not use HOT water on COLD glass surfaces. This can cause the glass to shatter and could result in personal injury. Allow glass fronts, ends and service doors to warm before applying hot water.

Exterior Surfaces

The exterior surfaces must be cleaned with a mild detergent and warm water to protect and maintain their attractive finish.

NEVER USE ABRASIVE CLEANERS OR SCOURING PADS. NEVER USE CAUSTIC SODA, KEROSENE, GASOLINE, THINNER, SOLVENTS, DETERGENTS, ACIDS, CHEMICALS OR ABRASIVES. DO NOT USE AMMONIA-BASED CLEANERS ON ACRYLIC PARTS.

Interior Surfaces

DO NOT USE AMMONIA-BASED PRODUCTS TO CLEAN LIGHT SHIELDS. NEVER USE ABRASIVE CLEANSERS OR SCOURING PADS.

The interior surfaces may be cleaned with most domestic detergents and sanitizing solutions with no harm to the surface. Always read and follow the manufacturer's instructions when using any cleaning product.

Inspect all LED connections and plug/receptacles for signs of arcing. Replace any component that shows signs of arcing. Make sure all unused receptacles have close-off covers securely attached.

CLEANING UNDERNEATH THE CASE

The case can be moved to facilitate cleaning. Unplug the merchandiser, and move it out if the way in order to sweep and mop the area underneath the case. Brush away all dirt and liter from the area. Ensure there is no dirt build up around the bottom of the case or near the intake or exhaust.

Do NOT Use:

- Abrasive cleansers and scouring pads, as these will mar the finish.
- Coarse paper towels on coated glass.
- Ammonia-based cleaners on acrylic parts.
- A hose on lighted shelves or submerge the shelves in water.
- Solvent, oil or acidic based cleaners on any interior surfaces.
- A hose on rail lights, canopy lights or any other electrical connection.
- Rinse with hot water, but do NOT flood.
- Allow merchandiser to dry before resuming operation.
- Wipe down lighted shelves with a damp sponge or cloth so that water does not enter the light channel. **DO NOT USE A HOSE OR SUBMERGE SHELVES IN WATER.**
- After cleaning is completed, restore power and turn on the merchandiser.

Do:

- **First turn off refrigeration, then disconnect electrical power.**
- Remove product and loose debris.
- Thoroughly clean all surfaces with soap and hot water. **DO NOT USE STEAM OR HIGH WATER PRESSURE HOSES TO WASH THE INTERIOR. THESE DESTROY MERCHANDISER'S SEALING CAUSING LEAKS AND POOR PERFORMANCE.**
- Take care to minimize direct contact between fan motors and cleaning or rinse water.

⚠ WARNING
 Product will be degraded and may spoil if allowed to sit in a non-refrigerated area.

Cleaning Shelves

Shelves and shelf clips are easily removed for cleaning the interior as well as the shelves themselves.

Cleaning Condenser Coils

To maintain peak operating efficiency, the coil should be cleaned at least once each month. A dirty coil slows product cooling significantly and increases energy consumption by as much as 20%. Dirt buildup on coils can also cause the compressor to lock up damaging the condenser unit. All VRL models have the same access panel design for commonality between merchandisers.

1. Loosen screws at each side of the front bottom grille, then lift up and pull off the grille.

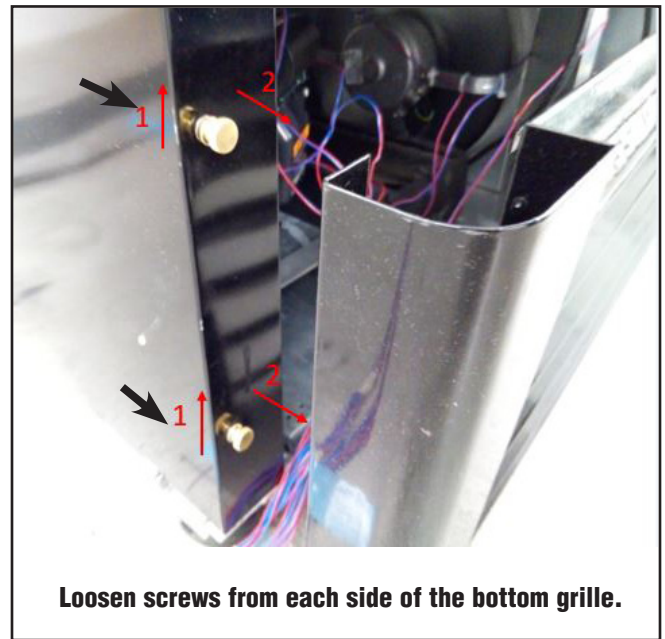

2. Next, detach the merchandiser's electrical wire harness.

3. Unscrew the stop bracket that holds the condensing unit to the rail base.

4. Grab the condensing unit from condensing unit handle.

USE ONLY THE UNIT HANDLE TO PULL OUT THE REFRIGERATION SYSTEM. PULLING ON REFRIGERATION LINES OR OTHER PARTS WILL CAUSE DAMAGE TO THE REFRIGERATION UNIT.

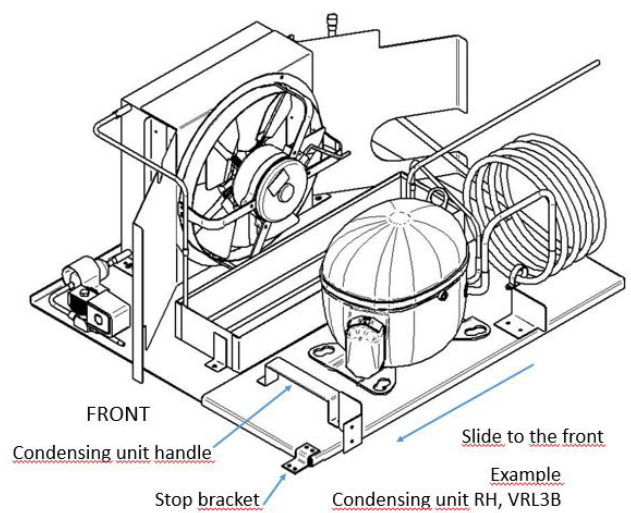

Refrigeration Unit

5. Use a soft hand brush attachment on a vacuum to remove accumulated dust and debris.

Consult an authorized service technician if more extensive cleaning is needed. If the refrigeration unit is damaged, it can be replaced with a new unit.

TIPS AND TROUBLESHOOTING

There are a few simple things to check before calling for service:

1. Product not cold? Refrigeration unit requires 24 hours at initial startup to cool down to operating temperature with **NO PRODUCT LOADED** in merchandiser. Ask when merchandiser was stocked, and what the usage has been. It may take 30 minutes or more for product to chill following stocking.
2. Check the door and door seal for air leaks.
3. Power Supply:
Is the unit plugged in?
Is there power to the unit?
4. Location
What are the ambient conditions—temperature and humidity, direct sun, nearby source of heat, such as oven or grill?
Is the unit level? Has the unit been moved recently?
5. Shelves and Stocking
Are the standard shelves in the correct places?
Is the product stocked properly?
Is the bottom shelf at the proper location?
6. Confirm that the defrost schedule is properly set.

IMPORTANT INFORMATION

For prompt service when contacting the factory, be sure to have the case model and serial number from the case serial plate.

⚠ WARNING

— LOCK OUT / TAG OUT —

To avoid serious injury or death from electrical shock, always disconnect the electrical power at the main disconnect when servicing or replacing any electrical component. This includes, but is not limited to, such items as doors, lights, fans, heaters, and thermostats.

ADJUSTING CLOSING TORQUE

Adjust closing torque by turning the bottom hinge pin in the direction the door closes. Use a 1/2 in. (13 mm) wrench. Turn the hinge pin until the door closes on its own, usually to 2 clicks or 1/2 turn.

DO NOT over-torque the hinge spring assembly. Excessive torque (over 1 full turn) will result in damage to the spring assembly and/or door. If door does not close on its own after one full turn (5 clicks), look for obstructions causing the door to hang up.

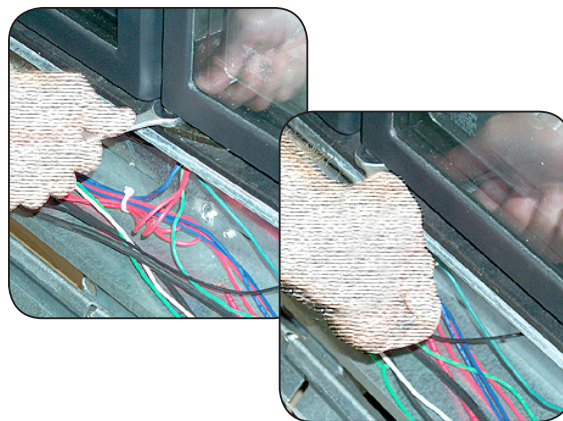

Adjusting Closing Torque

ADJUSTING DOOR SAG

To adjust door sag (saw-tooth effect from door to door), loosen the two hinge plate mounting screws using a Torx Plus no. 27 bit. Adjust hinge plate as needed, then tighten the screws.

CONDITIONING GASKETS

The manufacturer cannot control the environment surrounding cases during shipment. Temperature and humidity fluctuations during shipment, as well as excessive vibration, may promote gaps between gasket and frame. These gaps prevent gaskets from sealing even when correctly fitted at the factory.

This is not a warranty issue or defect.

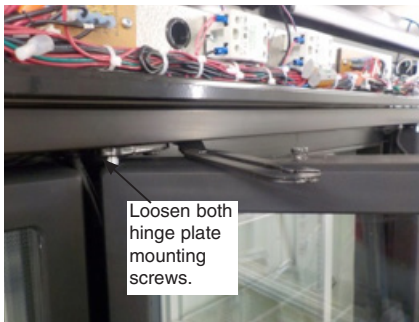

Adjusting Door Sag

Follow this procedure to ensure gaps close and gaskets seal properly:

1. Remove all shipping retainers and all packing material.
2. Close each door. Use a flashlight to identify any gaps between frame and gasket.
3. Energize all anti-sweat, fan and light circuits for at least two hours, but not more than four hours, prior to initiating the refrigeration cycle.

4. Monitor all gaps. If gaps remain at the end of four hours, follow the procedure for Restoring Gasket Seal, beginning on page 6 of this manual.

5. Initiate cooling sequence once gaps disappear.

Do not exceed 8 hours of energized circuits without refrigeration. Doing so may cause damage to the case and will void the warranty.

ATTENTION

TO ENSURE PROPER DOOR GASKET SEAL - REMOVE ALL SHIPPING RETAINERS AND ENERGIZE ALL ANTI-SWEAT, FAN & LIGHT CIRCUITS 2 TO 4 HOURS PRIOR TO INITIATING REFRIGERATION CYCLE.

DO NOT EXCEED 8 HOURS OF ENERGIZED CIRCUITS WITHOUT REFRIGERATION. DAMAGE OR PRODUCT FAILURE MAY OCCUR AND VOID THE WARRANTY.

DO NOT REMOVE THIS LABEL UNTIL REFRIGERATION IS INITIATED.

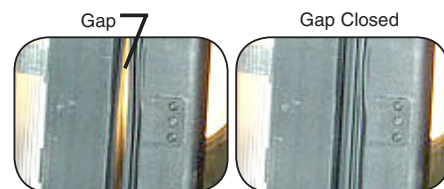
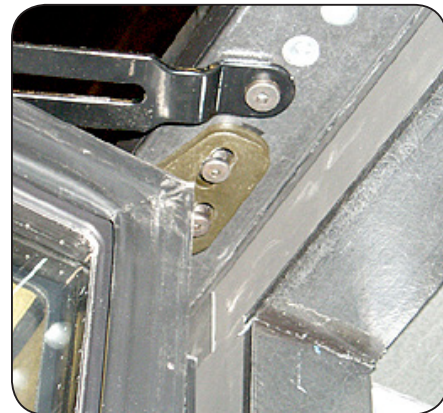

Before and After Gasket Conditioning

INNOVATOR DOOR MAINTENANCE

As part of an ongoing maintenance program for Innovator Doors, Hussmann recommends that the items below be checked annually.

- a) Proper door closing torque
- b) Gasket performance (check for tearing and proper sealing)
- c) Check the top hinge pin to ensure the pin is properly seated and not bent
- d) Check the bottom hinge plate for excessive wear (worn cam teeth)
- e) Proper operation of hold open brackets

1. Check the doors for proper closing torque:

Test 1: Open door 90 degrees and close it manually. Make sure the door opens and closes without binding

Test 2: Open door 90 degrees and release it. The door should close on its own

Test 3: Open door more than 3” but less than 6” and release it. The door should close on its own.

Torque adjustment, if needed, should be performed “one click” at a time. A “zero” torque door should not require more than 4 clicks. If the torque cam and hinge socket are severely rusted, both components should be replaced. A severely rusted cam / socket assembly will not hold torque. Rust on the cam socket assembly is usually caused by one of the following:

- High humidity conditions > ASHRAE Type I
- Cycling of the frame heaters

Note 1: A rusted torque cam / socket assembly can cause excessive wear on the torque rod’s spacer and sleeve bearing. The result is a door that can “seat” farther down the rod assembly to the point that it causes binding at the hold open bracket. It can also cause the top hinge pin’s sleeve bearing to deform.

If the door is seated too far down the torque rod assembly, it most likely damaged the top hinge pin sleeve bearing. If the pin is not bent, replacing the pin’s nylon sleeve bearing will be sufficient. Although the torque rod assembly’s sleeve bearing and spacer are replaceable, we recommend that a severely rusted torque rod assembly be replaced.

2) Inspect door gaskets:

- Check for tearing gaskets
- Make sure the gasket’s dart is properly seated into the door’s gasket groove.

3) Inspect the top hinge assembly for excessive movement at the top hinge socket.

- By design, the door will have a small, but discernible amount of movement at the top hinge pin / hinge plate socket joint. If excessive movement is detected, the hinge pin assembly should be inspected to ensure that the hinge pin is not bent (refer to note #1)

4) Inspect hold open bracket:

- Open the door to the “hold open” engagement position. The “hold open” bracket should retain the door.
- If the bracket fails to retain the door, replace the bracket and the shoulder screw.

5) If a door passes the three “open / close” tests, and there is no excessive movement at the top hinge pin, then it is highly unlikely that any components require replacement.

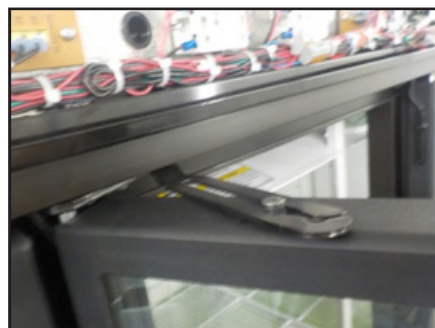

Self-Contained Refrigeration Equipment Maintenance Check List

***** Warranty does not cover issues caused by improper installation or lack of basic preventative maintenance. *****	
Record starting date	
Store Name and Number	
Store Address	
Unit Model Number	
Unit Serial Number	
Contractor/Technician	

PM activity-For visual inspection items, denote "ok or complete" in the column to right when PM has been performed. For measured data requested, record data requested in the appropriate column to the right)	Technician		Q1	Q2	Q3	Q4	Q1	Q2	Q3	Q4
	Quarterly	Semi-Annually								
Check in with store manager, record any complaints or issues they have with unit.	X									
Look unit over for any damage, vibrations or abnormal noise.	X									
Verify unit is level side to side and front to rear.	X									
Confirm refrigerant lines properly are secured and not touching or rubbing other lines, wires or frame work.	X									
Verify fan motors and motor mounts are tight.	X									
Confirm fan blade/s are tight and not rubbing or hitting.	X									
Make sure all electrical connections, factory and field, are tight.	X									
Verify electrical connections at lamps are they secure and dry.	X									
Check for and replace any frayed or chaffed wiring.	X									
Check all electrical wiring make sure it is secured and not on any sharp edges or hot lines.	X									
Check for air disturbances external to the unit. Heat and air registers, fans, and doors etc.	X									
Check for water leaks.	X									
Clean evaporator coil/s and fan blade/s. Do not use an acid base cleaner. Rinse off any cleaner residue.		X								
Clean discharge air honeycombs or grilles. Do not use an acid base cleaner. Rinse off any cleaner residue.		X								
Clean condenser coil/s and fan blade/s. Do not use an acid base Cleaner. Rinse off any cleaner residue.		X								
Clean condensate drain pan and drain line.		X								
Verify condensate drain lines are clear and functioning.		X								
Record voltage reading at unit with unit off?		X								
Verify condenser and evaporator fans are working.	X									
Record condenser air inlet temperature	X									
Record condenser air outlet temperature	X									
Is condenser air inlet or air exhaust restricted or recirculating?	X									
Use a handheld propane leak detector ("sniffer") to check for refrigerant leaks.	X									
Record voltage reading with unit running.		X								
Record compressor amp draw.		X								
Record defrost heater voltage and amp draw.		X								
Record anti-sweat heater voltage and amp draw.		X								
Record case product temperature.	X									
Record unit discharge air temperature.	X									
Record unit return air temperature.	X									
Record ambient conditions around unit (wet bulb temperature and dry bulb temperature).	X									
Check product loading, do not load beyond the units load limits.	X									
Verify clearances on sides/back of unit.	X									
Check unit controller for proper operation. See controller or 1/0 Manual for proper controller operation.		X								
Confirm door switches function.	X									
Verify unit doors and lids work and are sealed correctly.	X									
Verify that all the panels, shields and covers are in place.	X									

Technician Notes:

Form HSCW03 Rev-29 OCTOBER13

NOTES:

SERVICE

REPLACING DISPLAY LAMP

1. Disconnect power to the merchandiser. Remove the screws at the top of the unit display.
2. Remove the top panel.



Display Slides out to access Wireway

3. Remove the merchandiser's plexiglass panel.



4. Remove the cover display in order to access the LED fixture and LED power supply.



LED and Power Supply Shown with Display Panel Removed

5. Replace the LED with like fixture, and re-attach connection.
6. Replace the display panel cover.
7. Return power to the merchandiser.

REPLACING SHELF LAMPS

1. Disconnect power to the merchandiser. The LED fixtures are located behind the top of the door frame.



LED Location

2. Remove the screws and disconnect the LED fixture from the merchandiser.



3. Replace the LED with like fixture.



4. Return power to the merchandiser.

DEFROST HEATER REPLACEMENT

The defrost heaters are firmly embedded in the evaporator and held in place with spring clips. To remove the heater: first remove all spring clips and pull the defective heater out of the slots in the evaporator, starting at the wire supply lead.

The replacement heater should be firmly seated in the slots by using a small block of wood and a mallet. After the new heater is in place, replace all the spring retaining clips to assure heater retention. One lead of the defective heater may be used to pull the new leads through the cabinet to the respective terminals as marked on each lead.

NOTE: Care must be taken to ensure the drain stub is correctly inserted in the cabinet drain tube for proper drainage.

1. Remove the fan plenum to access the evaporator coil compartment.
2. The yellow screws can be removed by hand. The screws are around the fan plenum.



3. Remove the other screws in the drain cover.



4. Remove the fan plenum to access the coil.



Remove Fan Plenum

5. Identify the defrost heater leads, and unscrew them from terminal block by using a screw driver.

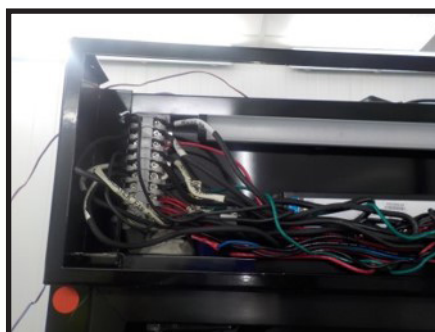

6. Remove plastic fasteners to detach defrost heater leads inside of the fan plenum compartment.



8. Remove the clips located in the coil. The main function of the clips is to attach the defrost heater to the coil.



7. Pull the heater lead from the inside.



Defrost Heater
Fan Plenum; Heater

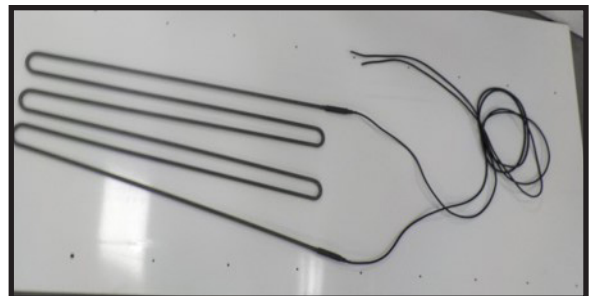

FRAME HEATER REPLACEMENT

Always turn off power to the case before working on any electrical components. The old wireway covers must be removed to access the door frame heaters. Begin by inserting a putty knife into the groove between the wireway cover and fiberglass frame, about an inch (25 mm) away from joints in the frame as shown. Carefully begin to pry off the cover.

A

Use a second putty knife or flat head screwdriver to hold up the cover as shown in **A**. Pry the remainder of the section up, using putty knife only, until the entire cover is off and the frame heater inside the door frame is exposed as shown in **B**.

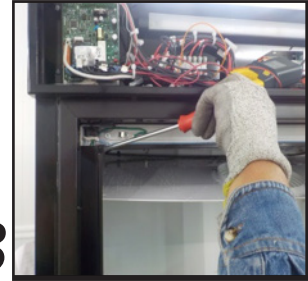
B

Door frame heaters may now be replaced.

During installation, the white portion of the heater should not come in contact with itself. The heater should be installed so that only one white portion of the wire enters the raceway. The other portion entering the raceway will be the black lead wire.

C

Once the heater wire is connected, check resistance (ohm reading) before replacing wireway covers. This will ensure that heater wire was not broken during installation. Wiring diagrams are shown on the last pages of this manual.

After covers are reinstalled, turn power on and verify that heaters are working properly.

D**E**

TECHNICAL INFORMATION

Visual Description of R290 Replacement Parts

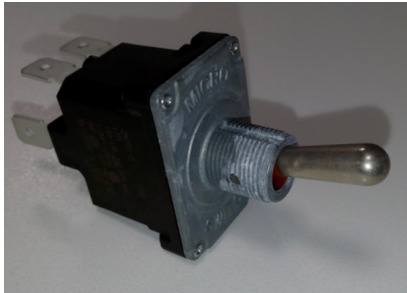

Main Switch

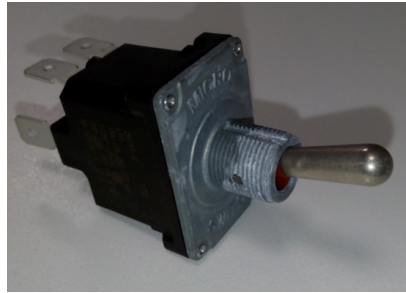

Light Switch



Solid State Relay 25 Amp



Control RTN400



Control Display KDE

WARNING

Component parts are specifically chosen for propane exposure and therefore non-incendive and non-sparking. Component parts shall be replaced with identical components, and servicing shall be done by factory authorized service personnel only, so as to minimize the risk of possible ignition due to incorrect parts or improper service.

VRL Replacement Parts List

Models

VRL1B VRL2B VRL3B

Standard Parts

Description	Part Number	VRL1B	VRL2B	VRL3B
Power Cord (NEMA L6-15P)	3042765	X	X	
Power Cord (NEMA L6-20P)	3024764			X
Light Switch	3038707	X	X	X
Sensor NTC 4 mts Green	3023554	X	X	X
Sensor NTC 4 mts Orange	3031571	X	X	X
Control Eliwell RTN400	3023537	X	X	X
Control Display KDE	3023552	X	X	X
Main Switch	3038707	X	X	X
Solid State Relay 25 Amp	3025263	X	X	X
Rail-Shelf (50")	3015493	X	X	X
Shelf Clips (insert into Rail-Shelf)	3009285	X	X	X
Defrost Heater Limit Thermostat	0344662	X	X	X
Wire Shelf (White) 21 X 24.812	3041925	X		
Wire Shelf Bottom (White) 21 X 24.812	3041926	X		
Wire Shelf (White) 21 X 24.312	3015794		X	X
Wire Shelf Bottom (White) 21 X 24.312	3015795		X	X
Led Light CTR 4000K	3024564		X	X
Led Light RH 4000K	3024573	X	X	
Door Black Low Temp LH	3017269	X	X	X
Door Torsion Door Assy	3017256	X	X	X
Door Gasket	3017271	X	X	X
Door Handle	051007300	X	X	X

WARNING

Component parts are specifically chosen for propane exposure and therefore non-incendive and non-sparking. Component parts shall be replaced with identical components, and servicing shall be done by factory authorized service personnel only, so as to minimize the risk of possible ignition due to incorrect parts or improper service.

Models

VRL1B VRL2B VRL3B

Refrigeration

Condenser Unit Assy LH	3016595			X
Condenser Unit Assy RH	3016596			X
Condenser Unit	3039076		X	
Condenser Unit Assy	3040873	X		
Compressor R290 208V/60Hz	3018571	X		X
Compressor R290 208V/60Hz	3037650		X	
Condenser	3016607	X	X	X
Condenser Fan Motor Assy 115V-230V (Motor Blade & Brkt)	3050263	X	X	X
Evaporator Coil	0534325	X		
Evaporator Coil	0547179			X
Evaporator Coil	0547180		X	
Evaporator Fan Motor 900 RPM	3055125	X		X
Evaporator Fan Motor 1200 RPM	3055126		X	
Evaporator Fan Blade 8.25"	3055130	X		X
Evaporator Fan Blade 7.00"	3055131		X	
Evaporator Fan Motor Bracket	3058806	X	X	X
Distributor Orifice 1/4	3020663	X	X	X
Capillary Tube .050" x 120	3020534	X		X
Capillary Tube .054" x 130	3037649		X	
Solenoid Valve 1/4 NC	3025473	X	X	X
Solenoid Valve Coil MKC1 240V/50-60Hz	E209828002	X	X	X
Filter Drier 704-200	0530462	X	X	X

VRL Replacement Parts List (Continued)

Models		VRL1B	VRL2B	VRL3B
Upper Lighted Display				
White Plexiglass Display 1 Door	3041296	X		
White Plexiglass Display 2 Doors	3020063		X	
White Plexiglass Display 3 Doors	3016789			X
Power Supply 100W 24VDC	3013744	X	X	X
Led Light Display	3004888	X		
Led Light Display	3004891			X
Led Light Display	3004897		X	
Magnetic Clip for Led Light	0523762	X	X	X

Models		VRL1B	VRL2B	VRL3B
Sheel Metal Replacement Parts Painted				
Support Post Rear Panel	3015489			X
Support Post Rear Panel	3023820		X	
Support Post Shelf	3015492		X	X
Pan Assy-Evap 1 Doors	3041395	X		
Pan Assy-Evap 2 Doors	3020069		X	
Pan Assy-Evap 3 Doors	3022670			X
Front Grill Assy 1 Doors	3041170	X		
Front Grill Assy 2 Doors	3018400		X	
Front Grill Assy 3 Doors	3016857			X
Ext Rear Bottom Panel 1 Doors	3041401	X		
Ext Rear Bottom Panel 2 Doors	3020018		X	
Ext Rear Bottom Panel 3 Doors	3015027			X

⚠ WARNING

Component parts are specifically chosen for propane exposure and therefore non-incendive and non-sparking. Component parts shall be replaced with identical components, and servicing shall be done by factory authorized service personnel only, so as to minimize the risk of possible ignition due to incorrect parts or improper service.

Dimensions

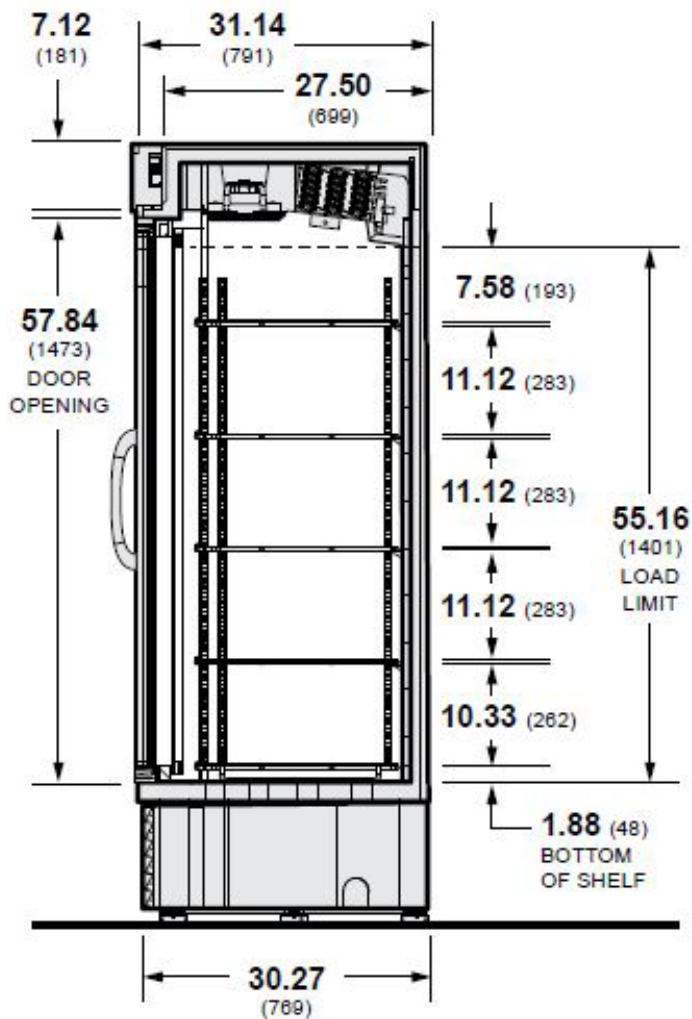
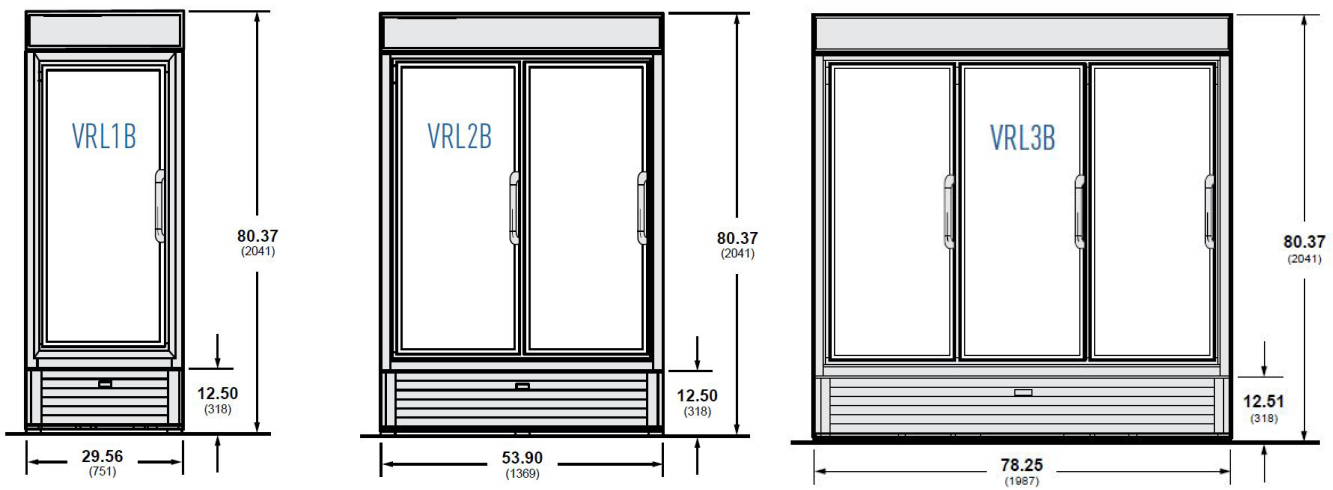

**VRL Cross Section Dimensions
shown as inches and (mm).**

Dimensions	Model	Doors	Refrig.	Cu. Ft. Capacity
	VRL1B	1	R-290	22.8
	VRL2B	2	R-290	44.5
	VRL3B	3	R-290	66.1

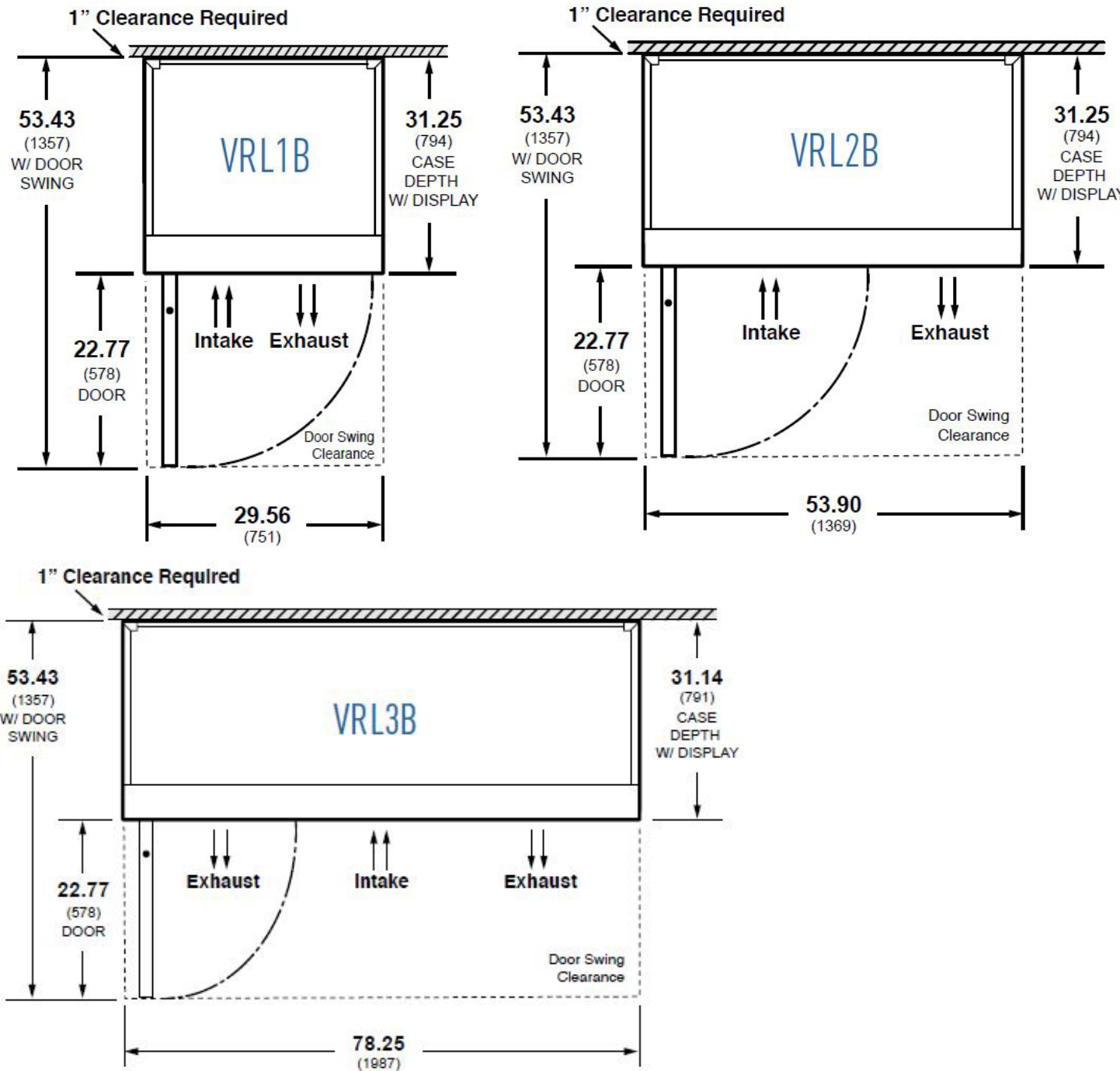

VRL Plan View Dimensions shown as inches and (mm).

Electrical Data

DEFROST DATA

Frequency (hr) 12

ELECTRIC DEFROST

Failsafe (minutes)
All models 35

**Defrost Termination
Temperature (F)** 48

PHYSICAL DATA

Refrigerant Charge (R290)
(0.150 kg each system)

VRL3B	10.6 oz	0.300 kg (2 systems)
VRL2B	5.3 oz	0.150 kg (1 system)
VRL1B	5.3 oz	0.150 kg (1 system)

Note: This data is based on store temperature and humidity that does not exceed 80°F and 55% R.H. unless otherwise stated. Schedule defrost at night while lights are off.

Electrical

Model	Nom. HP	Hz/Ph	Volts	Run Amps	Fuse Amps	NEMA Plugs	Refrig. Load (BTU/h)	A/C Load (BTU/h)	Energy Consumption (kWh/day)	Approx. Ship Wt. (lbs)
VRL1B	3/4	60/1	208-230	4.1	15	L6-15P	1025	2043	9.1	362
VRL2B	1	60/1	208-230	5.0	15	L6-15P	2100	3550	15.10	631
VRL3B	(2) 3/4	60/1	208-230	9.5	20	L6-20P	2900	4900	21.12	877

Evaporator Fans

	VRL1B	VRL2B	VRL3B (2 Condensing Units for VRL3)
Number of Motors	2	2	2
Amperes	0.26	0.26	0.26
Watts	32	32	32
Compressor LRA	30	30	28
Compressor RLA	4.8	4.8	4.45

Wiring Diagram

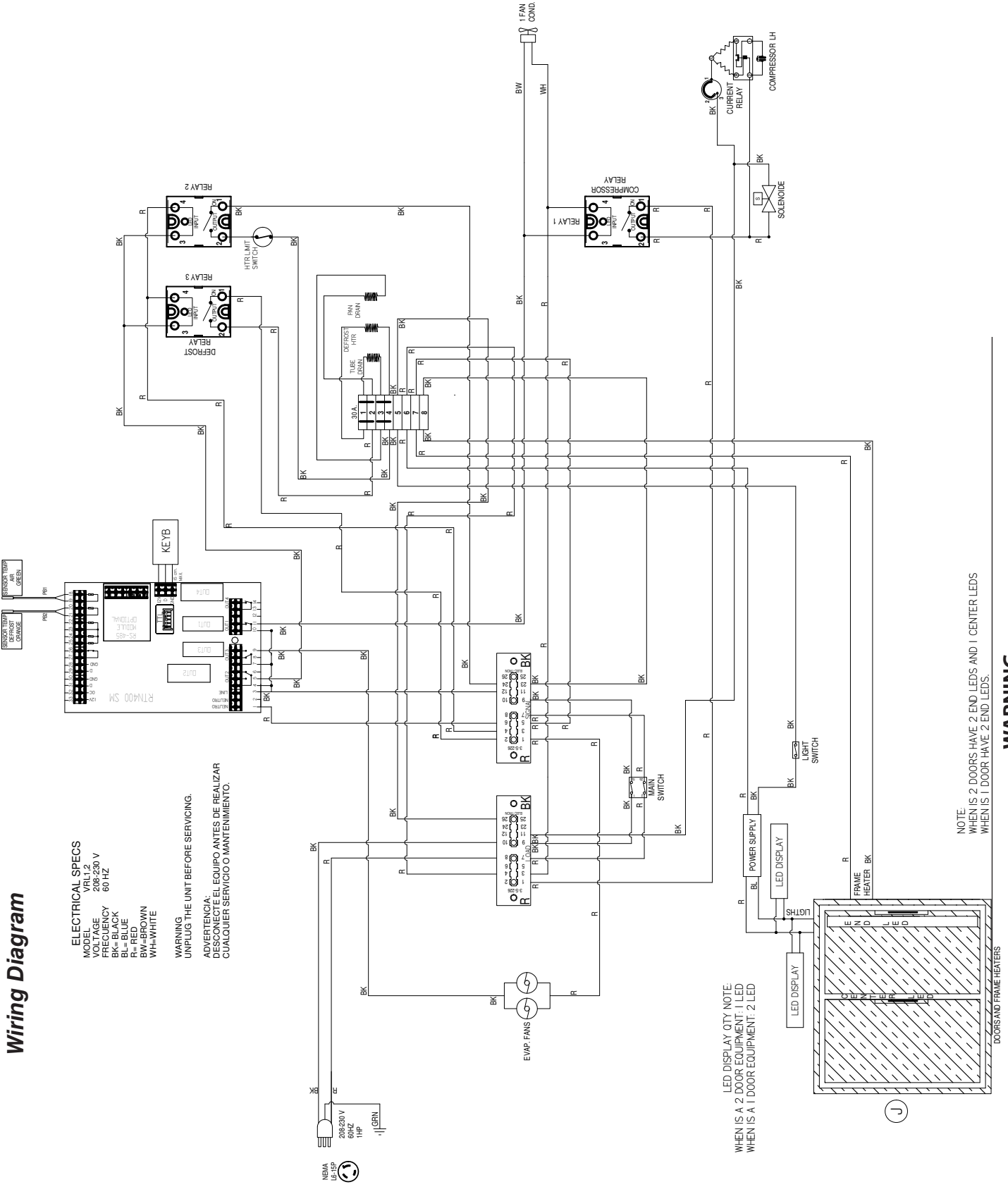

ELECTRICAL SPECS

MODEL VRL1.2
 VOLTAGE 208-230 V
 FREQUENCY 60 HZ
 BK=BLACK
 BL=BLUE
 R=RED
 BW=BLACK-BROWN
 WH=WHITE

WARNING
 UNPLUG THE UNIT BEFORE SERVICING.

ADVERTENCIA:
 DESCONECTE EL EQUIPO ANTES DE REALIZAR CUALQUIER SERVICIO DE MANTENIMIENTO.

LED DISPLAY QTY NOTE:
 WHEN IS A 2 DOOR EQUIPMENT: 1 LED
 WHEN IS A 1 DOOR EQUIPMENT: 2 LED

NOTE:
 WHEN IS 2 DOORS HAVE 2 END LEDES AND 1 CENTER LEDES
 WHEN IS 1 DOOR HAVE 2 END LEDES.

WARNING

All components must have mechanical ground, and the merchandiser must be grounded.
 R = Red Y = Yellow G = Green BK = Black W = White B = Brown O = Orange GR = Grey

VRL2B

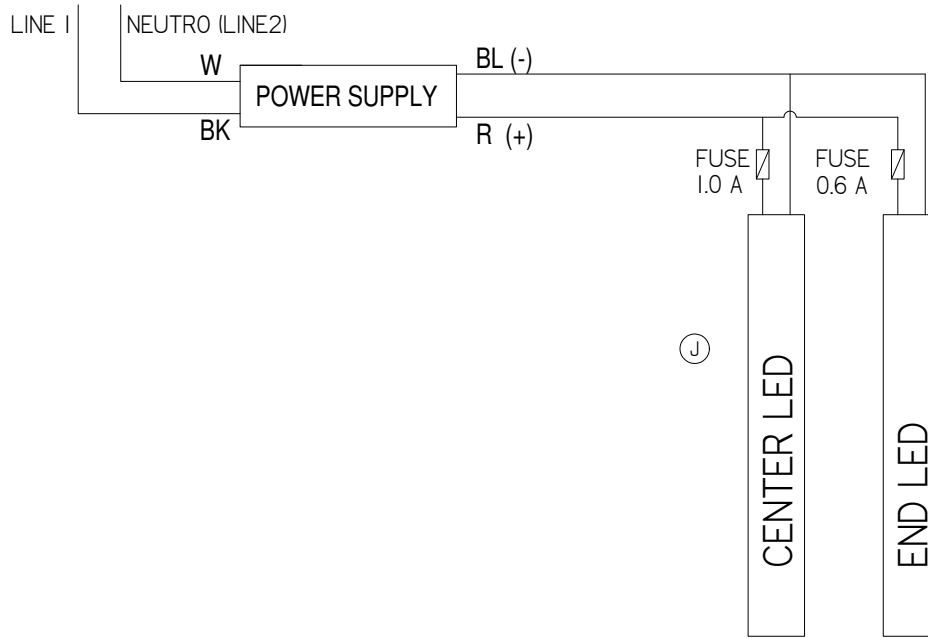

VRL1B

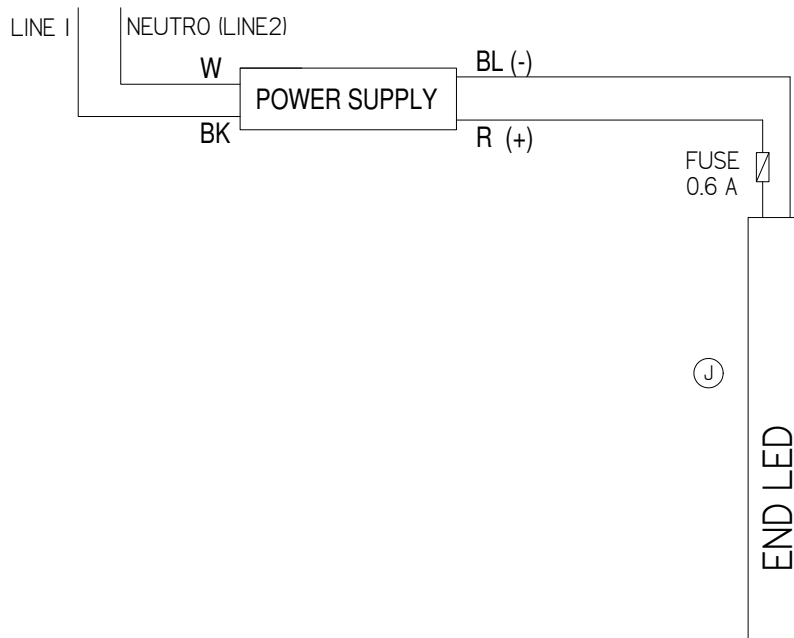

Wiring Diagram

ELECTRICAL SPECS
 MODEL VRL3
 VOLTAGE 208-230 V
 FREQUENCY 60 HZ
 BK= BLACK
 BL= BLUE
 R= RED
 BW=BROWN

WARNING:
 UNPLUG THE UNIT BEFORE SERVICING.

ADVERTENCIA:
 DESCONECTE EL EQUIPO ANTES DE REALIZAR
 CUALQUIER SERVICIO O MANTENIMIENTO.

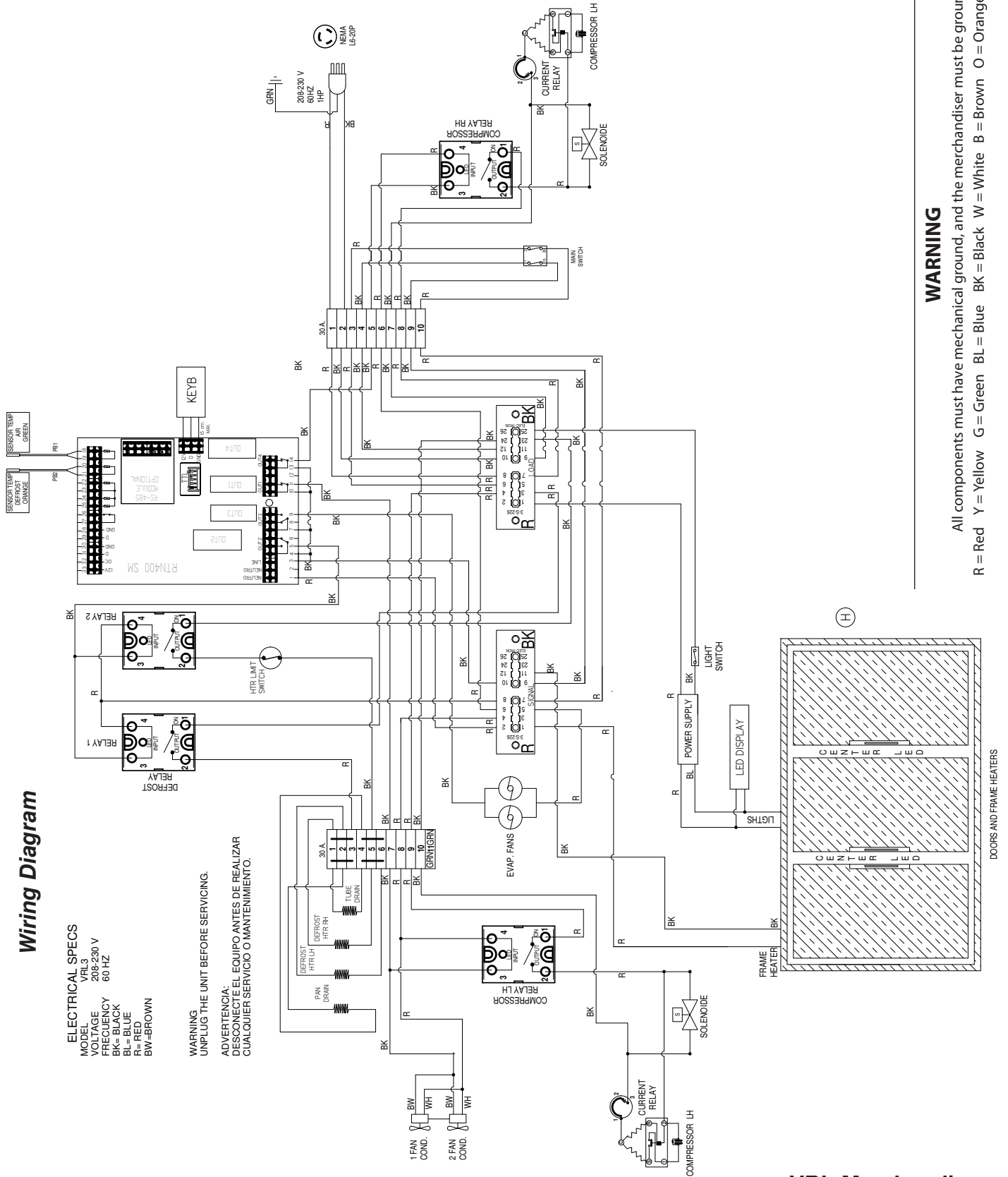

WARNING

All components must have mechanical ground, and the merchandiser must be grounded.

R = Red Y = Yellow G = Green BK = Black W = White B = Brown O = Orange GR = Grey

VRL3B

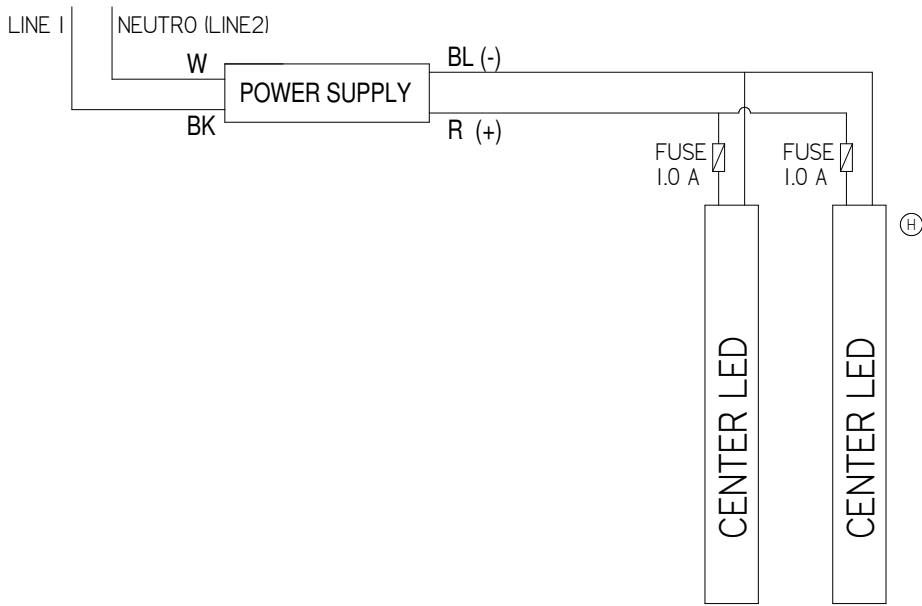



HUSSMANN[®]

**To obtain warranty information
or other support, contact your
Hussmann representative.
Please include the model and
serial number of the product.**

Husmann Corporation
12999 St. Charles Rock Road
Bridgeton, MO 63044-2483
www.husmann.com