

# HUSSMANN®



DOE 2017  
Energy Efficiency  
Compliant

## **VRM** *Medium Temperature Self Contained Glass Door Merchandisers*

*with R290 Refrigerant*

### **WARNINGS:**

If the information in these instructions are not followed exactly, a fire or explosion may result, causing property damage, personal injury or death.

Installation and service must be performed by a qualified installer or service agency.

**READ THE ENTIRE MANUAL BEFORE  
INSTALLING OR USING THIS EQUIPMENT.**

The unit uses R-290 (propane) gas as the refrigerant. R-290 (propane) is flammable and heavier than air. It collects first in low areas but can be circulated by the fans. If propane gas is present or even suspected, do not allow untrained personnel to attempt to find the cause. The propane gas used in the unit has no odor. The lack of smell does not indicate a lack of escaped gas. If a leak is detected, immediately evacuate all persons from the store, and contact the local fire department to advise them that a propane leak has occurred. Do not let any persons back into the store until the qualified service technician has arrived and that technician advises that it is safe to return to the store. No open flames, cigarettes or other possible sources of ignition should be used inside or in the vicinity of the units.

**FAILURE TO ABIDE BY THIS WARNING COULD  
RESULT IN AN EXPLOSION, DEATH, INJURY AND  
PROPERTY DAMAGE.**

**IMPORTANT**

Keep in store for future reference!



## *Installation & Operation Manual*

**P/N 3034041\_E**

April 2019

*Spanish 3034047*

*French 3034046*



## BEFORE YOU BEGIN

Read these instructions completely and carefully.



### PERSONAL PROTECTION EQUIPMENT (PPE)

Personal Protection Equipment (PPE) is required whenever installing or servicing this equipment. Always wear safety glasses, gloves, protective boots or shoes, long pants, and a long-sleeve shirt.

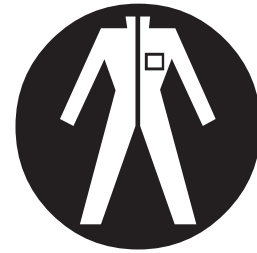
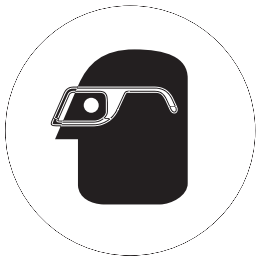

1. If the information in these instructions are not followed exactly, a fire or explosion may result, causing property damage, personal injury or death.
2. Installation and service must be performed by a qualified installer or service agency.
3. This unit is designed only for use with R-290 (propane) gas as the designated refrigerant.

#### **THE REFRIGERANT LOOP IS SEALED. ONLY A QUALIFIED TECHNICIAN SHOULD ATTEMPT TO SERVICE!**

- Propane is flammable and heavier than air.
- It collects first in the low areas but can be circulated by the fans.
- If R-290 (propane) is present or even suspected, do not allow untrained personnel to attempt to find the cause.
- The propane gas used in the unit has no odor.
- The lack of smell does not indicate a lack of escaped gas.
- If a leak is detected, immediately evacuate all persons from the store, and contact the local fire department to advise them that a propane leak has occurred.
- Do not let any persons back into the store until the qualified service technician has arrived and that technician advises that it is safe to return to the store.
- A hand-held propane leak detector (“sniffer”) shall be used before any repair and/or maintenance.
- No open flames, cigarettes or other possible sources of ignition should be used inside the building where the units are located until the qualified service technician and/or local fire department determines that all propane has been cleared from the area and from the refrigeration systems.
- Component parts are designed for propane and non-incendive and non-sparking. Component parts shall only be replaced with identical repair parts.

**FAILURE TO ABIDE BY THIS WARNING COULD RESULT IN AN EXPLOSION, DEATH, INJURY AND PROPERTY DAMAGE.**

# ATTENTION

Merchandiser must operate for 24 hours  
before loading product!

Regularly check merchandiser temperatures.

Do not break the cold chain. Keep products  
in cooler before loading into merchandiser.

These merchandisers are designed  
for only pre-chilled products.



IMPORTANT  
KEEP IN STORE FOR FUTURE REFERENCE  
*Quality that sets industry standards!*

12999 St. Charles Rock Road • Bridgeton, MO 63044-2483

U.S. & Canada 1-800-922-1919 • Mexico 1-800-890-2900

[www.hussmann.com](http://www.hussmann.com)

© 2019 Hussmann Corporation

REVISION HISTORY

REVISION E

Updated parts list, capacity, wiring diagrams, load limit drawing, cross section, LED info, light switch, added recovering refrigerant steps;

REVISION D

Removed Fan Key Page; Updated parts list and diagrams; added California Warning.

REVISION C

Updated part numbers and wiring diagrams.

REVISION B

Added VRM 1-door cases  
Changed info about door torque.

ORIGINAL ISSUE — JULY 2017

**ATTENTION**

Adjust closing torque by turning the bottom hinge pin in the direction the door closes.

Use a 1/2 inch (13 mm) wrench, and turn the hinge pin until the door closes on its own.

Usually it takes two clicks or a half turn.



**CAUTION**

Do NOT remove shipping crate until the merchandiser is positioned for installation.

**CAUTION**

Excessive ambient conditions may cause condensation and therefore sweating of doors. Facility operators should monitor doors and floor conditions to ensure safety of persons.

\*\*\*\*\*

ANSI Z535.5 DEFINITIONS

 • **DANGER** – Indicate[s] a hazardous situation which, if not avoided, will result in death or serious injury.

 • **WARNING** – Indicate[s] a hazardous situation which, if not avoided, could result in death or serious injury.

 • **CAUTION** – Indicate[s] a hazardous situation which, if not avoided, could result in minor or moderate injury.

• **NOTICE** – *Not related to personal injury* – Indicates[s] situations, which if not avoided, could result in damage to equipment.

## INSTALLATION

### NSF LISTING

These merchandisers are manufactured to meet ANSI / UL 471 standard requirements for safety. Proper installation is required to maintain this listing. Near the serial plate, each case carries a label identifying the type of conditions for which the merchandiser was tested.

**ANSI/NSF-7 Type I – Display Refrigerator / Freezer Intended for 75°F / 55% RH Ambient Application**

**ANSI/NSF-7 Type II – Display Refrigerator / Freezer Intended for 80°F / 55% RH Ambient Application**

**ANSI/NSF-7 – Display Refrigerator Intended for Bulk Produce**

### FEDERAL / STATE REGULATION

These merchandisers, at the time they are manufactured, meet all federal and state / provincial regulations.

### HUSSMANN PRODUCT CONTROL

The serial number and shipping date of all equipment is recorded in Hussmann's files for warranty and replacement part purposes. All correspondence pertaining to warranty or parts ordering must include the serial number of each piece of equipment involved. This is to ensure the customer is provided with the correct parts.

### SHIPPING DAMAGE

All equipment should be thoroughly examined for shipping damage before and during unloading. This equipment has been carefully inspected at our factory. Any claim for loss or damage must be made to the carrier. The carrier will provide any necessary inspection reports and/or claim forms.

### Apparent Loss or Damage

If there is an obvious loss or damage, it must be noted on the freight bill or express receipt and signed by the carrier's agent; otherwise, carrier may refuse claim.

### Concealed Loss or Damage

When loss or damage is not apparent until after equipment is uncrated, retain all packing materials and submit a written response to the carrier for inspection within 15 days.

### LOCATION

These merchandisers are designed for displaying products in air conditioned stores where temperature is maintained at or below the ANSI / NSF-7 specified level and relative humidity is maintained at or below 55%.

<p><b>Recommended operating ambient temperature is between 60°F (15.6°C) to 80°F (26.7°C). Maximum relative humidity is 55%.</b></p>
--

Placing refrigerated merchandisers in direct sunlight, near hot tables or near other heat sources could impair their efficiency. Like other merchandisers, these merchandisers are sensitive to air disturbances. Air currents passing around merchandisers will seriously impair their operation. Do NOT allow air conditioning, electric fans, open doors or windows, etc. to create air currents around the merchandiser. *VRM units in take air and exhaust air through the front of the case, and require no clearance space on top, at back or either side.*

# 6 INSTALLATION

## SELF CONTAINED (LOCATION)

Product should always be maintained at proper temperature. This means that from the time the product is received, through storage, preparation and display, the temperature of the product must be controlled to maximize the life of the product.

BE SURE TO POSITION SELF CONTAINED MERCHANDISERS PROPERLY.

VRM models have vented base panels to allow air circulation through the condensing unit.

Allow for a minimum 36 in. clearance in the front. Blocking or restricting air flow will adversely affect performance and may damage the refrigeration system.

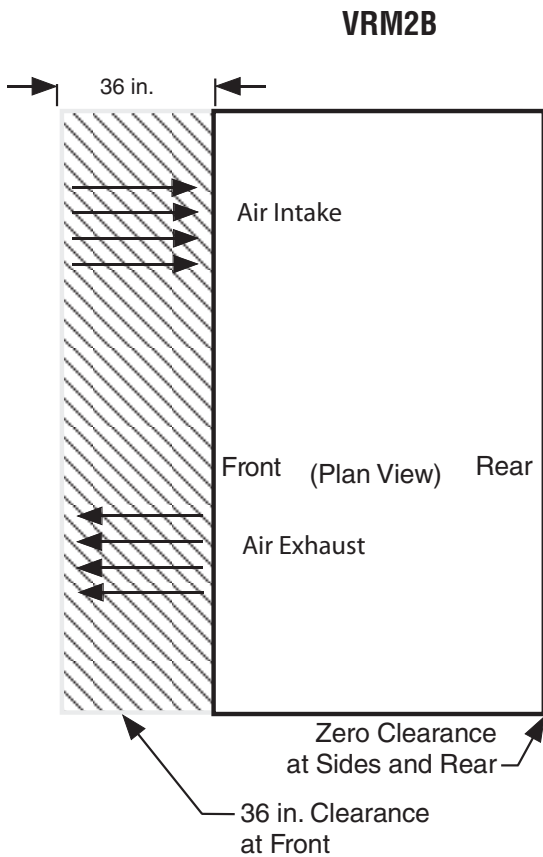
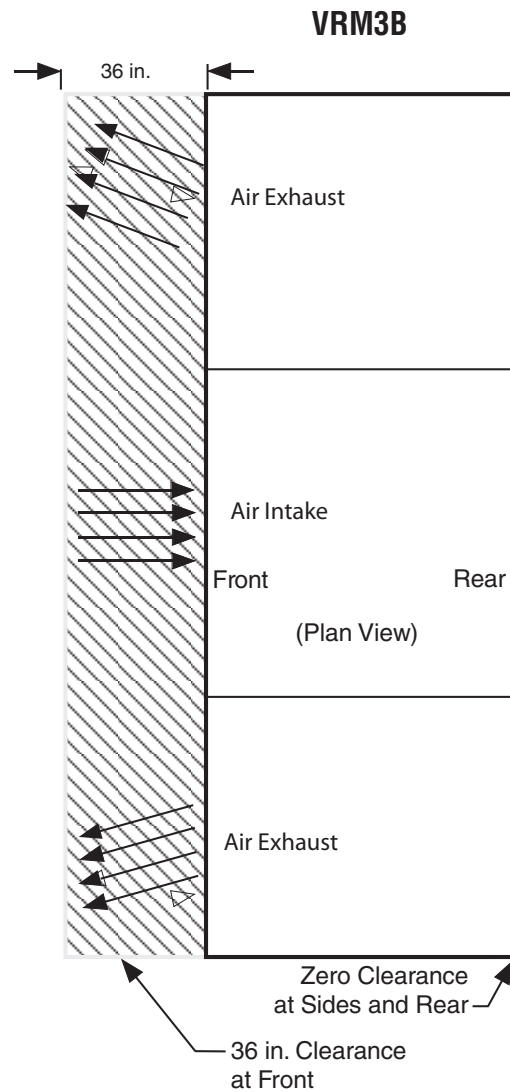
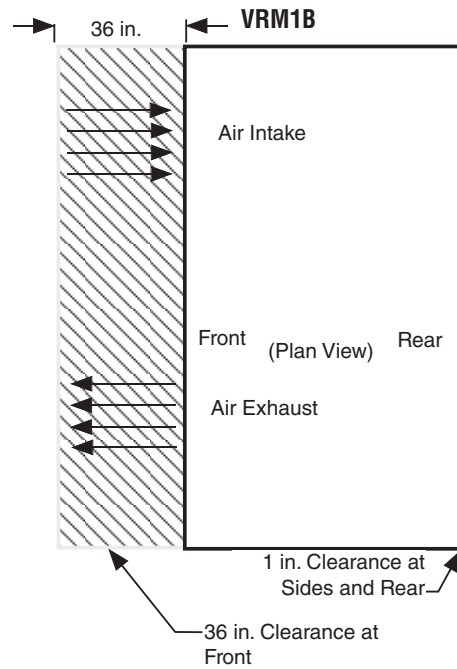

## UNLOADING

### Unloading from Trailer:

Lever Bar (also known as a Mule, Johnson Bar, J-Bar, Lever Dolly, or Pry Lever)

Move the merchandiser as close as possible to its permanent location and remove all packaging. Check for damage before discarding packaging. Remove all separately packed accessories such as kits and shelves.

Improper handling may cause damage to the merchandiser when unloading. To avoid damage:

1. Do not drag the merchandiser out of the trailer. Use a Johnson bar (Mule).
2. Use a forklift or dolly to remove the merchandiser from the trailer.



### EXTERIOR LOADING

Do NOT walk on top of the merchandiser or damage to the merchandisers and serious personal injury could occur.

MERCHANDISERS ARE NOT STRUCTURALLY DESIGNED TO SUPPORT EXCESSIVE EXTERNAL LOADING such as the weight of a person. Do not place heavy objects on the merchandiser.

### SHIPPING SKID

Each merchandiser is shipped on a skid to protect the merchandiser's base and to make positioning the case easier.

Remove the top of the crate and detach walls from each other (if applicable). Lift crate from the skid. Unscrew the case from the skid. The merchandiser can now be lifted off the crate skid. **Lift only at base of skid!** Remove any braces and/or skids attached (blanket wrapped merchandiser may have skids).

**DO NOT TILT MERCHANDISER ON ITS SIDE OR END WHEN REMOVING SKID.**

Once the skid is removed, the merchandiser must be lifted —NOT PUSHED— to reposition. To remove the skid, remove screws attaching skid to the merchandiser.

Check floor where merchandisers are to be set to if it is a level area. Determine the highest part of the floor.



This warning does not mean that Hussmann products will cause cancer or reproductive harm, or is in violation of any product-safety standards or requirements. As clarified by the California State government, Proposition 65 can be considered more of a 'right to know' law than a pure product safety law. When used as designed, Hussmann believes that our products are not harmful. We provide the Proposition 65 warning to stay in compliance with California State law. It is your responsibility to provide accurate Proposition 65 warning labels to your customers when necessary. For more information on Proposition 65, please visit the California State government website.

## MODEL DESCRIPTION

VRM merchandisers are medium temperature self-contained cabinets, designed for the display of dairy products, deli items and beverages.

### Design Features

- Contemporary styling places maximum attention on merchandising
- All VRM merchandisers have the same access panel design for commonality between merchandisers
- Self-closing Innovator doors. Positive seal, torsion type closure system
- Triple-pane thermal insulated glass door assemblies
- Magnetic door gaskets of one-piece construction, removable without tools for ease of cleaning
- Merchandiser can be placed against wall - no air gap is required behind the case
- Digital display in center of case air grill

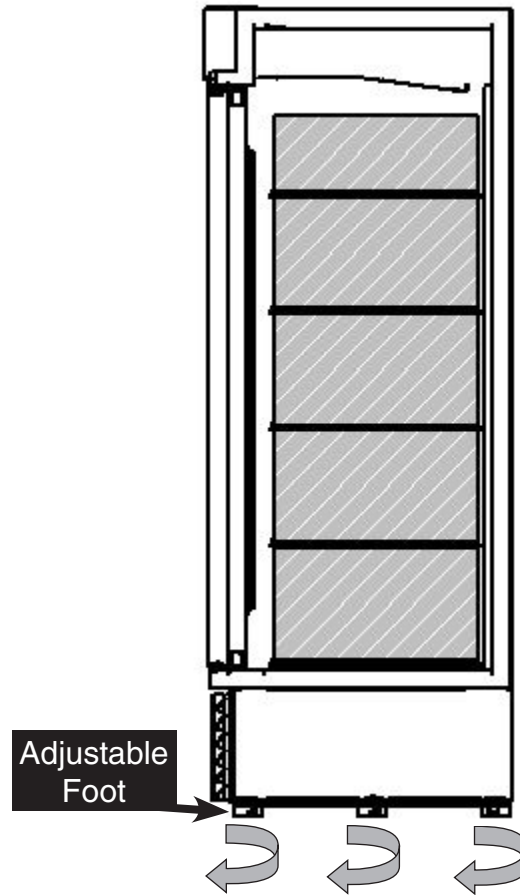

## CABINET LEVELING

This merchandiser must be installed level (from back to front, and side to side) to allow maximum draining of the condensate water as well as proper door alignment and operation. Choose a level area to install case.

VRM2B and VRM3B also have an adjustable foot at center front and back. Turn the foot levelers clockwise to add length to each foot for leveling.

When optional casters are used, screw them tight to the merchandiser base. Once in final position, lock each caster.

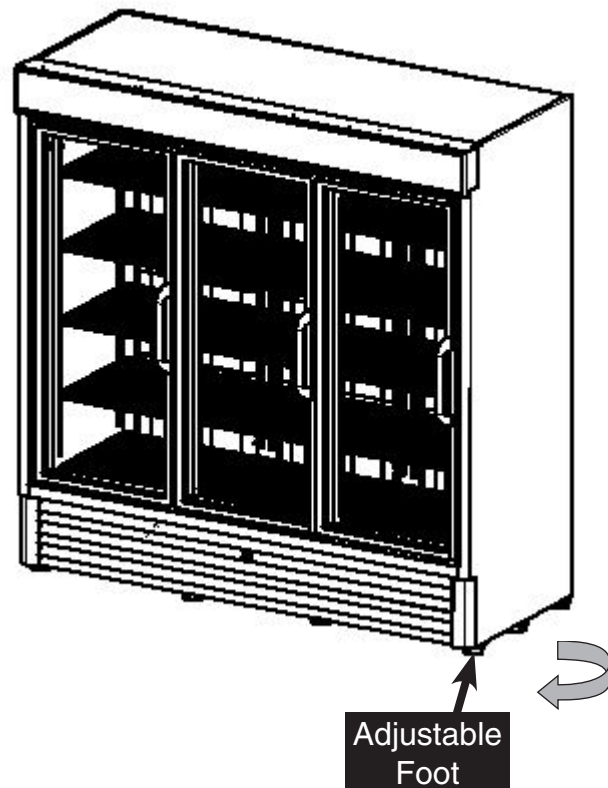



## SHELF INSTALLATION

After the cabinet is leveled, the shelves may be installed. Wire shelves are adjustable. Shelf spacing can be adjusted by positioning the shelf clips according to individual loading requirements.

VRM merchandisers have four movable wire shelves and one bottom wire shelf, per door.

## LAMPS

This merchandiser has a light switch inside, at the right side of the plenum. The switch controls the display lighting and interior lighting.

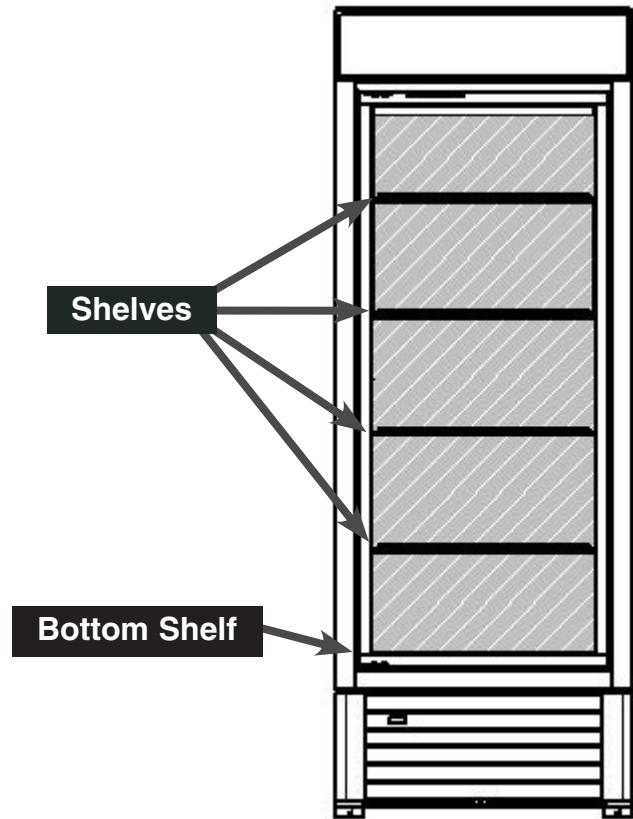

Light Switch

## STOCKING

Product should NOT be placed in case until merchandiser is at proper operating temperature. **VRM merchandisers must remain in operation for at least 24 hours before product may be loaded into case cabinet.**

Proper rotation of product during stocking is necessary to prevent product loss. Always bring the oldest product to the front and set the newest to the back.

**AIR EXHAUST AND RETURN GRILLE MUST REMAIN OPEN AND FREE OF OBSTRUCTION AT ALL TIMES.**

Do not allow product, packages, signs, etc. to block air exhaust or return grille. Do not use non-approved shelving, baskets, display racks, or any accessory that could hamper air curtain performance.

**DO NOT STOCK PRODUCT IN THE TOP FOUR INCHES OF VRM CASES BECAUSE PRODUCT WILL BLOCK THE COLD AIR FLOW.**

## LOAD LIMITS

Product must be within designated load limit to ensure proper refrigeration and air curtain performance.

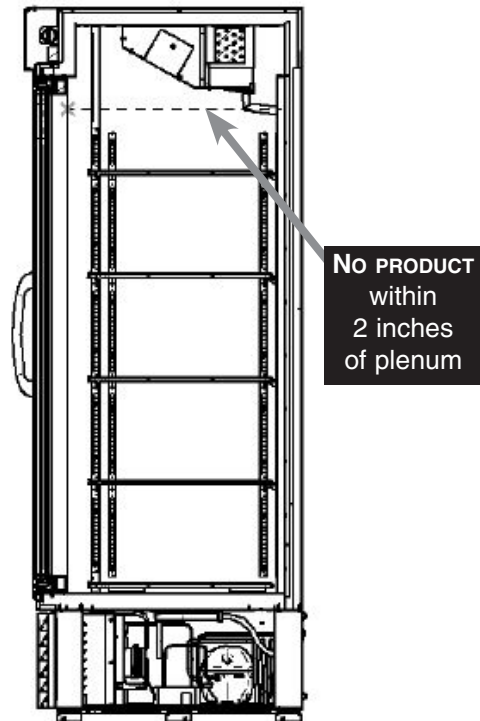

Load Limit for VRM Merchandisers

### At no time should product be stocked:

- Beyond the front and rear of the shelves
- Near the air supply duct located at the top rear of case
- Near or covering the evaporation fan grilles
- Within four inches of the top of the cabinet (This space must be free of product and other materials.)

**DO NOT LOAD CASE WITH WARM PRODUCT.**

### Hussmann Self-Contained Refrigeration Equipment Start Up Check List

\*\*\*Please note that failure to follow this start-up document may void your factory warranty\*\*\*

Step	Startup Activity	Check
1	Locate, read and maintain install/operation manual in a safe place for future reference.	<input type="checkbox"/>
2	Examine unit. Confirm there is NO damage or concealed damage.	<input type="checkbox"/>
3	Level the unit, side to side and front to rear.	<input type="checkbox"/>
4	Remove all shipping brackets/compressor straps/bolts etc.	<input type="checkbox"/>
5	Unit must be run on a dedicated electrical circuit without the use of an extension cord.	<input type="checkbox"/>
6	Ensure that the proper electrical requirements for the equipment are supplied.	<input type="checkbox"/>
7	Verify field electrical connections are tight.	<input type="checkbox"/>
8	Verify all electrical wiring is secured and clear of any sharp edges or hot lines.	<input type="checkbox"/>
9	Verify the condensate drain line is properly trapped and pitched.	<input type="checkbox"/>
10	Verify all required clearances on the sides and back of unit.	<input type="checkbox"/>
11	Verify there are no air disturbances external to the unit. Heat and air registers, fans, and doors etc.	<input type="checkbox"/>
<b>Advise owner/operator that merchandiser must operate at temperature for 24 hrs prior to loading with product.</b>		

Form HSCW01 Rev. 30MAY12 P/N 0525209\_B

**LEGAL DISCLAIMER:**

Hussmann shall not be liable for any repair or replacements made without the written consent of Hussmann, or when the product is installed or operated in a manner contrary to the printed instructions covering installation and service which accompanied such product.

*NOTES:*

## ELECTRICAL / REFRIGERATION

### PLUG

The plug cord is 9 ft long and is located on the right hand rear of the merchandiser. Disconnect power before servicing. VRM merchandisers require a dedicated electrical circuit with ground. 12AWG is the minimum sized acceptable wire.



## WARNING

**Merchandiser must be grounded.  
Do not remove the power supply cord ground.**

- The VRM models require a dedicated 15 AMP/115V circuit with a grounded wall receptacle (NEMA 5-15R).
- Always use a dedicated circuit with the amperage stated on the unit.
- Plug into an outlet designed for the plug.
- Do not overload the circuit.
- Do not use long or thin extension cords. Never use adapters.
- If in doubt, call an electrician.

**ALWAYS CHECK THE SERIAL PLATE FOR COMPONENT AMPERES**

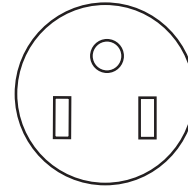

NEMA 5-15P  
All Models



## CAUTION

**Risk of Electric Shock. If cord or plug becomes damaged, replace only with a cord and plug of the same type.**

Nominal Voltage	Minimum Voltage	Maximum Voltage
120	108	132



## WARNING

**— LOCK OUT / TAG OUT —**

***To avoid serious injury or death from electrical shock, always disconnect the electrical power at the main disconnect when servicing or replacing any electrical component. This includes, but is not limited to, such items as doors, lights, fans, heaters, and thermostats.***

### Before Beginning Any Service or Repair:

Use a hand-held propane leak detector (“sniffer”) to ensure no propane is present in the immediate area, the inside of the display case and the inside of the refrigeration system. R-290 is an odorless refrigerant. Keep the area clear of all customers and non-essential or unauthorized personnel.

Verify that all repair parts are identical models to the ones they are replacing. Do not substitute parts such as motors, switches, relays, heaters, compressors, power supplies or solenoids. Failure to do so can result in an explosion, death, injury and property damage. Parts used on hydrocarbon cases must meet specific UL certification for non-incendive or non-sparking components. Use only Hussmann approved parts approved through the Hussmann Performance Parts Website.

<https://parts.hussmann.com/>

Brazing must not begin before all propane has been cleared from the immediate area — the inside of the displays case and the inside of the refrigeration system.

## **WARNING**

**Only Hussmann or factory trained technicians should service or repair this R-290 (propane) equipment.**

**Failure to follow instructions can result in an explosion, death, injury and property damage.**

If a leak is detected, follow store safety procedures. It is the store’s responsibility to have a written safety procedure in place. The safety procedure must comply with all applicable codes such as local fire department’s codes.

At minimum, the following actions are required:

- Immediately evacuate all persons from the store, and contact the local fire department to advise them that a propane leak has occurred.
- Call Hussmann and/or a qualified service agent and inform them that a propane sensor has detected the presence of propane.
- Do not let any persons back into the store until the qualified service technician has arrived and that technician advises that it is safe to return to the store.

- The propane gas used in the unit has no odor. The lack of smell does not indicate a lack of escaped gas.

- A hand-held propane leak detector (“sniffer”) should be used before any repair and/or maintenance is attempted. All repair parts must be identical models to the ones they are replacing.

- No open flames, cigarettes or other possible sources of ignition should be used inside the building where the units are located until the qualified service technician and/or local fire department determines that all propane has been cleared from the area and from the refrigeration systems.

## REPLACING REFRIGERATION SYSTEM COMPONENTS

### **DANGER**

**Only Hussmann service technicians or technicians qualified to handle R-290 (propane) refrigerant should service or repair this R-290 (propane) equipment. Failure to follow instructions can result in an explosion, death, injury and property damage.**

### STEPS TO RECOVER REFRIGERANT

1. Make sure you are in a well ventilated area before making any service or repair to the refrigeration system.
2. Disconnect all power sources from the system. Some systems may have more than one plug or power supply.
3. Tap system with line tap valves, attaching gauges to the high and low sides of the system.
4. Connect hose to an evacuated recovery tank. Open refrigeration gauges and recovery tank.
5. With the suction valve in vacuum, the refrigerant will be recovered into the recovery tank.
6. Once recovered, close the tank valve and remove the gauge from the tank and connect nitrogen tank to the system to purge it with nitrogen.
7. Pull vacuum to a minimum of 200 microns or lower.



**refrigeration  
line tapping  
valve**

## CHARGING

A calibrated scale with +/-2 gram accuracy must be used to charge the system. The charge amount is shown on the serial plate. Only R-290 grade refrigerant can be used. Standard propane does not meet the purity/moisture content of R-290, and therefore cannot be used to charge cases.

No gas charge adjustments are allowed. When connecting hoses between the refrigeration system, manifold gauges, and refrigerant cylinder, ensure that the connections are secure and there are no potential sources of ignition nearby. Ensure that contamination of different refrigerants does not occur when using charging equipment.

Use dedicated hoses to service R-290 (propane) refrigeration systems. Hoses or lines should be as short as possible to minimize the amount of refrigerant contained in them.

Ensure that the refrigeration system is properly grounded prior to charging the system with refrigerant, to avoid the potential for static build-up.

## WARNING

**Component parts shall be replaced with like components, and servicing shall be done by factory authorized service personnel only, so as to minimize the risk of possible ignition due to incorrect parts or improper service.**

Extreme care must be taken not to overfill the refrigeration system. After charging, carefully disconnect the hoses, attempting to minimize the quantity of refrigerant released. Further leak check the service ports, hoses, refrigerant tanks. The service ports shall be checked for leaks using a hydrocarbon leak detector with a sensitivity of 3 grams/year (0.106 Oz/year) leak rate.

Thoroughly leak check the service ports. If no leak is present, use a pinch-off tool to close the ends of the service tubes before brazing them shut. If a Schrader valve is used on the compressor service tube, it must be removed and the previous steps followed in order to braze the service tube shut.





Typical Sensor to Control Configuration

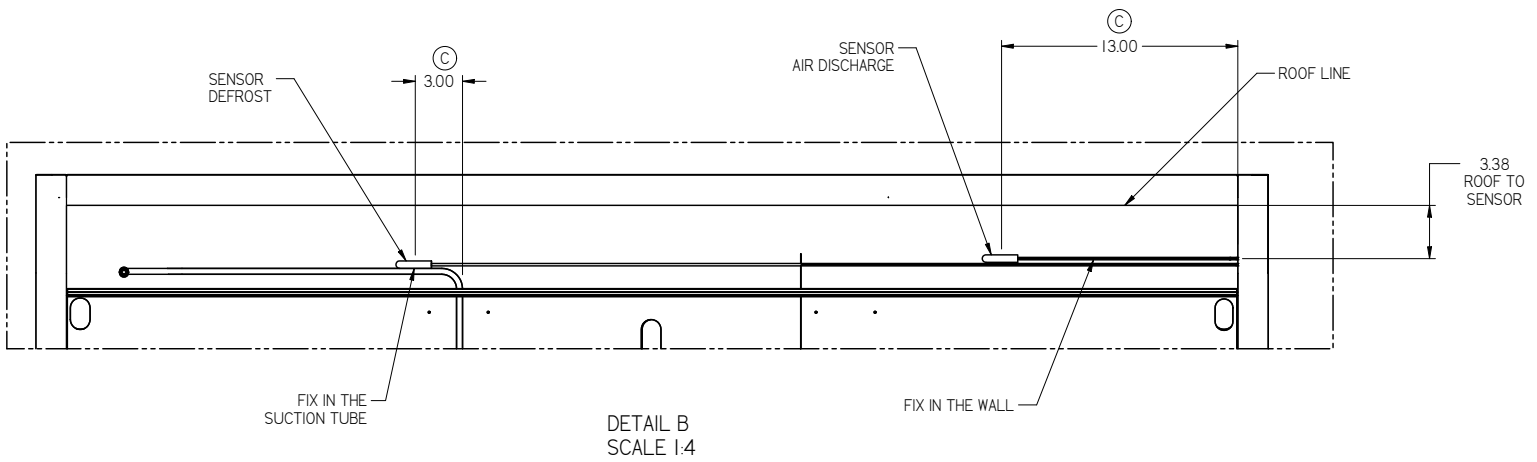
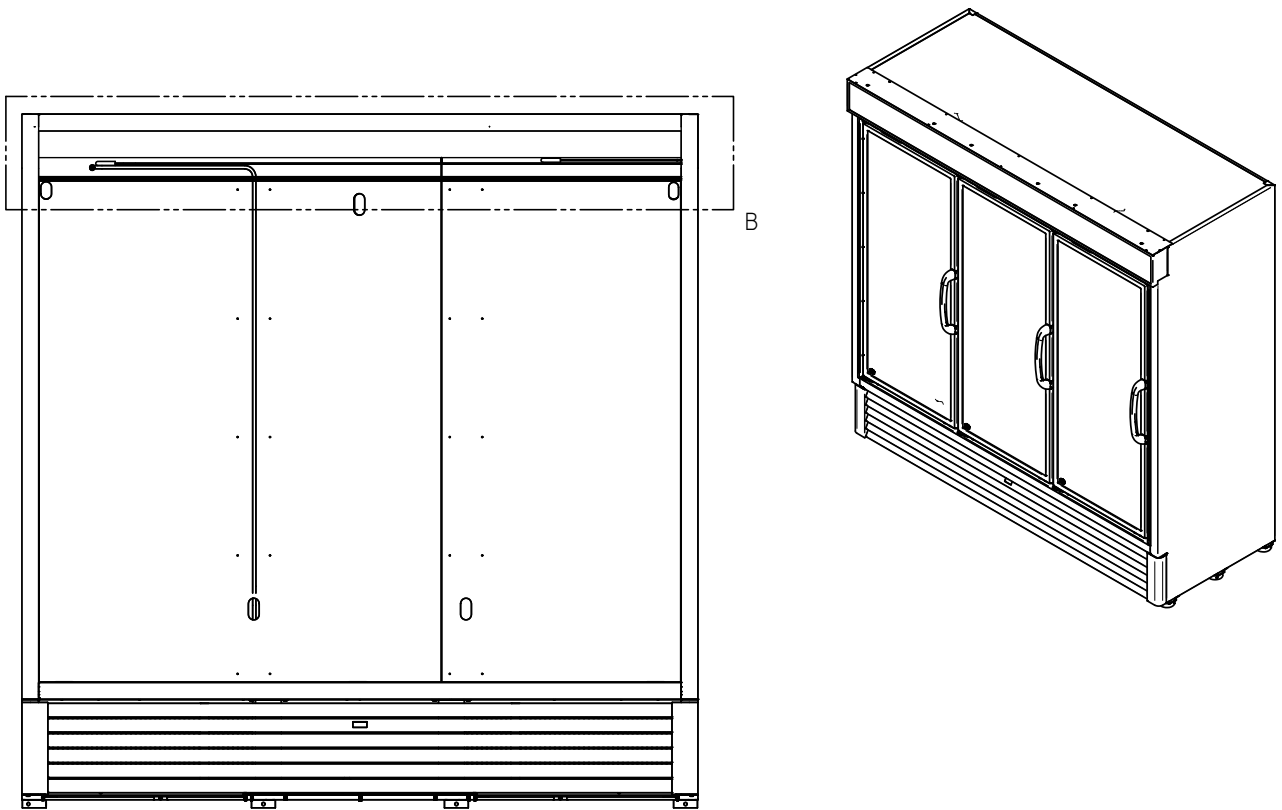

Typical Sensor to Control Configuration

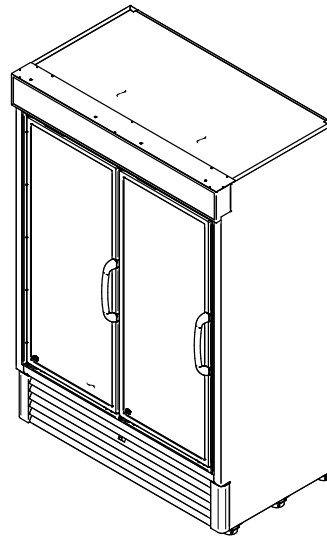
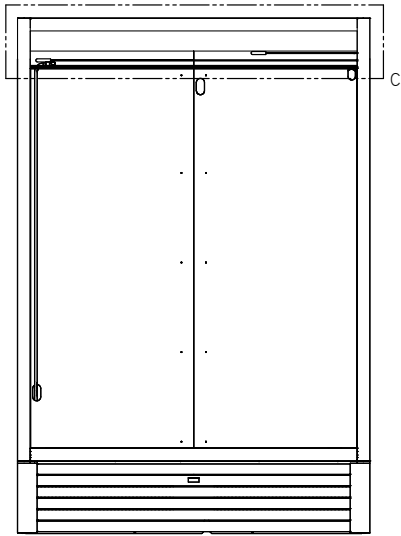

**VRM2B**

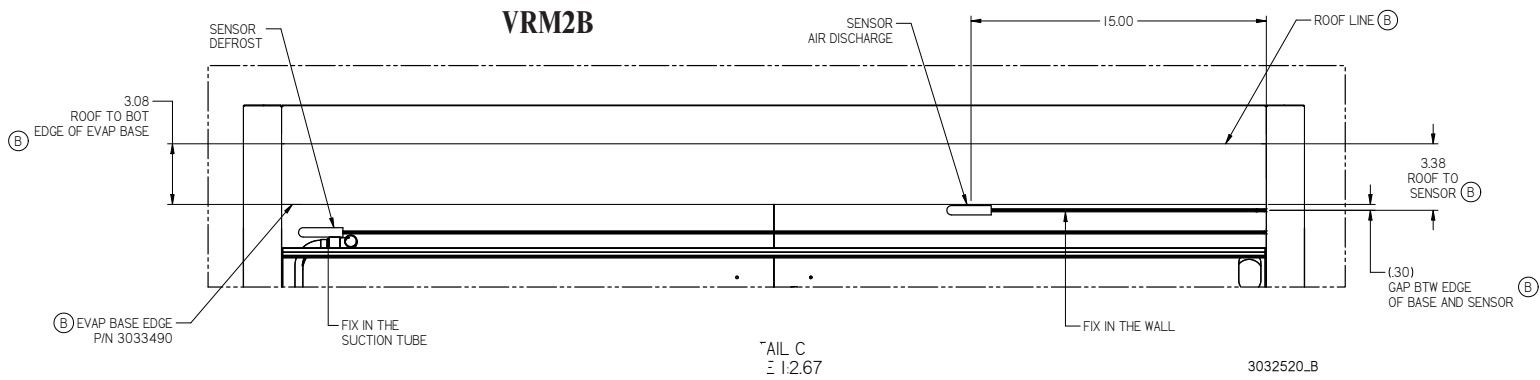

**VRM1B**

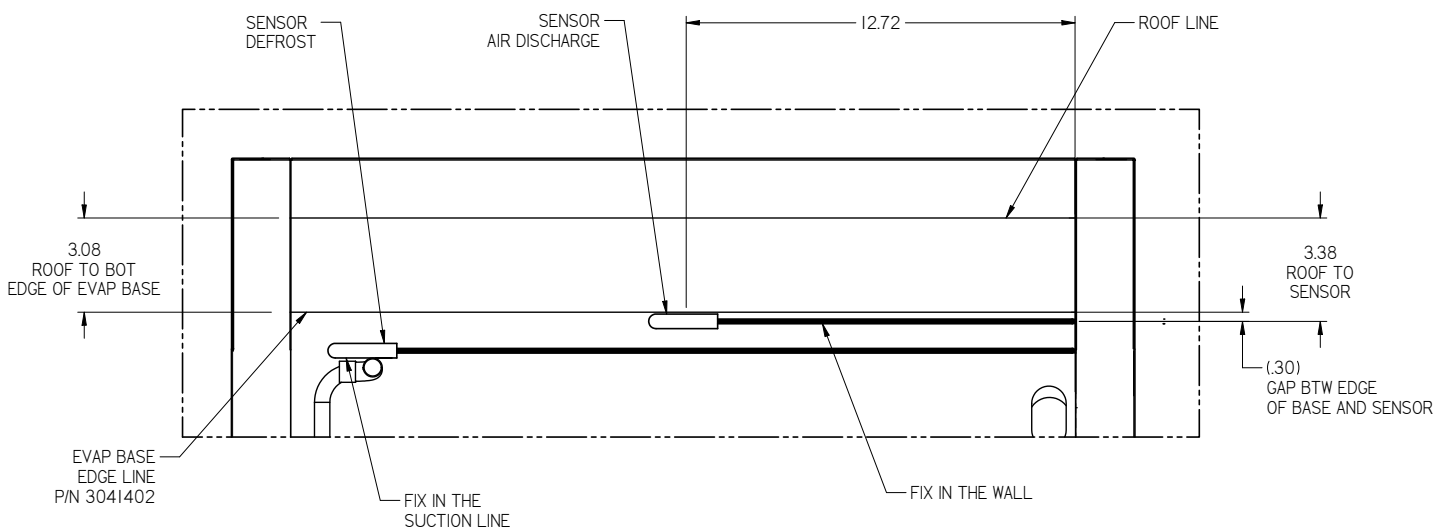

## CONTROLLER

### Hussmann Controller Operation RTN

1. Plug the merchandiser plug into its receptacle.

- a. The controller display will illuminate.
- b. The interior light will illuminate.

2. After the control preprogrammed time delay of up to 6 minutes, the compressor and evaporator fan(s) will start if the control is calling for cooling.

3. The control will cycle the compressor but may also cycle evaporator fan(s) on and off determined by the Set-Point and Differential temperatures.

- a. The Set-Point is the adjustable preprogrammed temperature.
- b. The Differential is the non-adjustable pre programmed temperature.
- c. The Control is designed to read and display a cabinet temperature not a product temperature.

This cabinet temperature may reflect the refrigeration cycle of the Set-Point and it's Differential. The most accurate temperature on a cabinets operation is to verify the product temperature.

Taking as an example a VRL case, freezer, If the Set-Point is  $-12^{\circ}\text{F}$  and the Differential is  $9^{\circ}\text{F}$ . (Set-Point)  $-12^{\circ}\text{F} + 9$  (Differential) =  $-3^{\circ}\text{F}$ . The compressor and evaporator fan(s) will cycle off  $-12^{\circ}\text{F}$  and back on at  $-3^{\circ}\text{F}$ .

#### Main Features:

- Panel-mounted
- Energy saving algorithms and optimised defrost control
- 8 preloaded applications
- Defrost at single / double evaporator
- Frame Heater
- Local network auto-configuration
- Direct load connection (up to 2 HP)
- Supply voltage control LVD
- Presence of an open collector output



### KDEPLUS BUTTONS

The **KDEPlus** keyboard has 4 keys, as shown in the illustration:



**Key Functions:**

- 2 ON/OFF regulators for HOT/COLD
- Single defrost and double evaporator  
(heatings, modulated heaters, reverse cycle, hot gas)
- Evaporator fans and condenser fans
- Frame Heater
- AUX
- Light
- Door switch
- ON /OFF
- Deep cooling cycle
- Day / Night
- Diagnostics
- “Easy Map” programming
- Programmable inputs/outputs
- LINK2 local area network
- RS485 communication protocol: Modbus
- Compatible with Device Manager (DM)
- Compatible with Unicard and Multi-function key

**TECHNICAL DATA**

Classification:	electronic automatic control (not safety) device for incorporation
Mounting:	panel mounting
Type of action:	1.B
Pollution class:	2
Material class:	IIIa
Overvoltage category:	II
Nominal pulse voltage:	2500V
Temperature:	Use: -5 ... +55°C - Storage: -30 ... +85°C
Power supply:	SMPS 100-240Va ±10% 50/60 Hz
Power consumption:	5.5W max
Fire resistance category:	D
Software class:	A
RTC battery life:	In absence of external power, the clock battery will last 3 years.

## FURTHER INFORMATION

### INPUT CHARACTERISTICS

Measurement range:	<b>NTC:</b> -50.0°C ... +110°C; <b>PTC:</b> -55.0°C ... +150°C; <b>PT1000:</b> -60.0°C ... +150°C (on 3-digit display with +/- sign)
Accuracy:	±1.0° for temperatures below -30°C ±0.5° for temperatures between -30°C and +25°C ±1.0° for temperatures above +25°C
Resolution:	1 or 0.1°C
Buzzer:	NO
Analogue/Digital Inputs:	5 configurable NTC/PTC/PT1000/DI inputs 1 multi-function, voltage-free digital input (D.I.)

### OUTPUT CHARACTERISTICS

Digital Outputs:	<b>OUT1:</b> 1 SPST relay: 2HP max 240V~ <b>OUT2:</b> 1 SPDT relay: 1HP max 250V~ <b>OUT3:</b> 1 SPDT relay: 8(4)A max 250V~ <b>OUT4:</b> 1 SPST relay: 8(4)A max 250V~
OC (Open Collector) Output:	<b>OC:</b> 1 multifunctional output: 12V= 20mA

### MECHANICAL CHARACTERISTICS

Dimensions:	121x92 mm
Terminals:	faston and screw for wires with cross-section of 2.5mm <sup>2</sup>
Connectors:	TTL for Unicard / Device Manager connection (via DMI)
Humidity:	Usage / Storage: 10...90% RH (non-condensing)

### REGULATIONS

Electromagnetic compatibility:	The device complies with Directive 2004/108/EC
Safety:	The device complies with Directive 2006/95/EC
Food Safety:	The device complies with standard EN13485 as follows: <ul style="list-style-type: none"> <li>• Suitable for storage.</li> <li>• Application: air.</li> <li>• Climate range A</li> <li>• measurement class 1 in the range from -25°C to 15°C (*)</li> </ul> <b>(* with Eliwell probes only)</b>

**NOTE:** The technical specifications stated in this document regarding measurement (range, accuracy, resolution, etc.) r the instrument alone and not to any accessories provided, such as the probes. This means, for example, that the error introduced by the probe must be added to the error of the instrument.

# CONNECTIONS

## TERMINALS

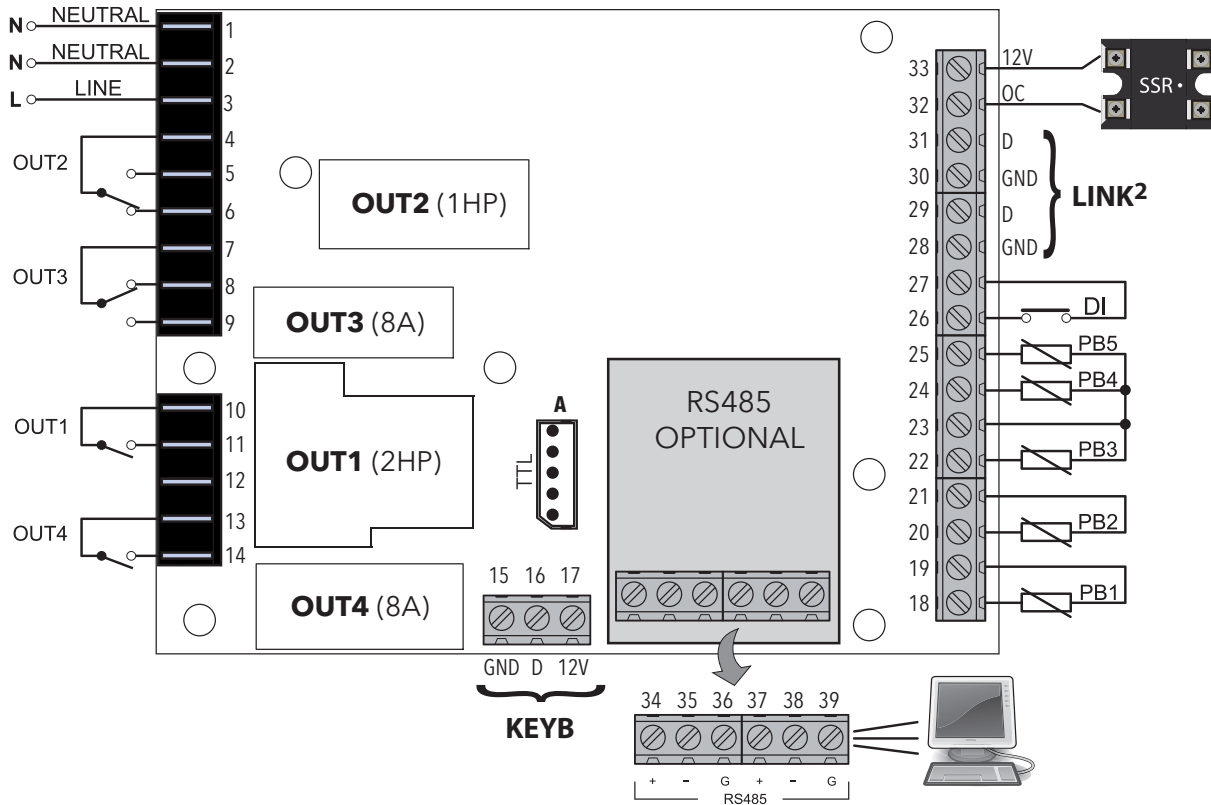

\* **N.B.:** analogue inputs PB1...PB5 can also be configured as Digital Inputs DI.

TERMINALS			
<b>1-2</b>	NEUTRAL. These are power supply terminals.	<b>15-16-17</b>	Connection to KDEPlus or KDWPlus external keyboard or ECPlus echo module.
<b>3</b>	LINE. These are power supply terminals.	<b>19-18</b>	PB1 probe connection.
<b>4</b>	OUT2 Shared Terminal	<b>21-20</b>	PB2 probe connection.
<b>5</b>	N.O. OUT2	<b>23-22</b>	PB3 probe connection.
<b>6</b>	N.C. OUT2	<b>23-24</b>	PB4 probe connection.
<b>7</b>	OUT3 Shared Terminal	<b>23-25</b>	PB5 probe connection.
<b>8</b>	N.C. OUT3	<b>27-26</b>	Digital input (DI).
<b>9</b>	N.O. OUT3	<b>28-29</b>	LINK <sup>2</sup> . Connection 1 - local area network.
<b>10</b>	OUT1 Shared Terminal	<b>30-31</b>	LINK <sup>2</sup> . Connection 2 - local area network.
<b>11</b>	N.O. OUT1	<b>32-33</b>	Open Collector Output (OC).
<b>12</b>	Not Used	<b>A</b>	TTL Unicard/DMI/Multi Function Key connection
<b>13</b>	OUT4 Shared Terminal	<b>34-35-36</b>	RS485. Connection 1 - Supervision Gateway.
<b>14</b>	N.O. OUT4	<b>37-38-39</b>	RS485. Connection 2 - Supervision Gateway.

## LED

RTN400 family controllers will also function even if a keyboard has not been connected.

With **KDEPlus** or **KDWPlus** keyboards (which are the same and guarantee the same functions), the display will be as follows:

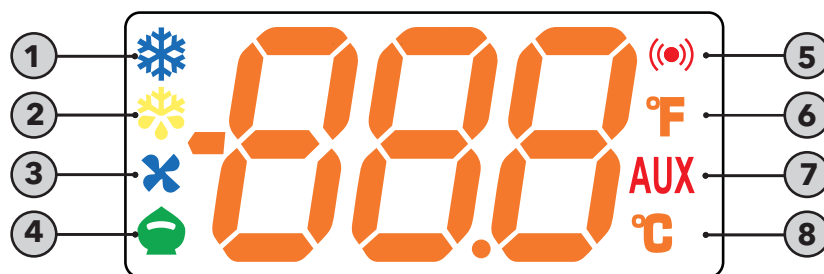

Meaning of LEDs:

No	Icon	LED	Operation	Meaning
1		<b>Compressor</b>	Permanently on	compressor on
			Blinking	Delay, protection or start-up blocked
			OFF	otherwise
2		<b>Defrost</b>	Permanently on	Defrost active
			Blinking	Activated manually or from Digital Input
			OFF	otherwise
3		<b>Fans</b>	Permanently on	Fans active
			OFF	otherwise
4		<b>Reduced SET / Economy</b>	Permanently on	Energy Saving active
			Blinking	Reduced setpoint active
			OFF	otherwise
5		<b>Alarm</b>	Permanently on	alarm active
			Blinking	Alarm acknowledged
			OFF	otherwise
6		<b>°F readout</b>	Permanently on	°F setting (dro = 1)
			OFF	otherwise
7	<b>AUX</b>	<b>AUX</b>	Permanently on	Aux output active and/or light on
			Blinking	Deep cooling on
			OFF	otherwise
8		<b>°C readout</b>	Permanently on	°C setting (dro = 0)
			OFF	otherwise

**N.B.:** When the instrument is powered on it performs a lamp test, during which time the display and LEDs will flash for several seconds to check that they all function correctly.

## KDEPLUS BUTTONS

The **KDEPlus** keyboard has 4 keys, as shown in the illustration:







Each key has a different function depending on whether it is:

- Pressed and released
- Pressed for at least 5 seconds
- Pressed and held at start-up
- Pressed in combination with another key.

### KEYS

The following table summarizes the function of each key:

No	Key	Action		
		Pressed and released	Press for at least 5 secs	Start-up
1		<ul style="list-style-type: none"> <li>• Scrolls through menu items</li> <li>• Decreases values</li> </ul>	Activates the <b>Manual Defrost function</b> (from outside menus).	---
2		<ul style="list-style-type: none"> <li>• Scrolls through menu items</li> <li>• Decreases values</li> </ul>	Function can be configured by the user (from outside menus). (see parameter H32)	---
3		<ul style="list-style-type: none"> <li>• Returns to the previous menu level</li> <li>• Confirms parameter value</li> </ul>	Activates the Stand-by function (from outside menus).	---
4		<ul style="list-style-type: none"> <li>• Displays any alarms (if active)</li> <li>• Opens Machine Status menu</li> <li>• Confirms commands</li> </ul>	Opens the Programming Menu (User and Installer parameters)	When pressed during start-up it enables the user to select the application to be loaded.



### SETPOINT: SETTING AND EDIT LOCK

To display the Setpoint value, press the **set** key to enter the "Machine Status" menu, then press the **set** key again when the "SEt" label is displayed.

The Setpoint value appears on the display. To change the Setpoint value, press the **UP** and **DOWN** keys within 15 seconds. Press **set** to confirm the modification.

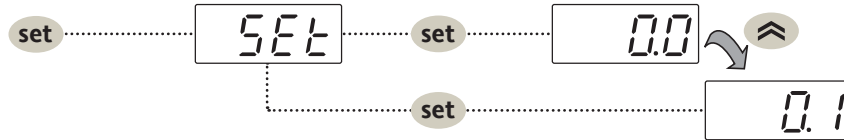

It is possible to disable the keypad on this device.

The keypad can be locked by programming the "LOC" parameter appropriately.

With the keypad locked, you can still access the "Machine Status" menu by pressing **set** to display the Setpoint, but you cannot edit it. To disable the keypad lock, repeat the locking procedure.

### DISPLAY PROBES VALUE

To display the value read by probes connected to the device, press the **set** key and enter the "Machine Status" menu, then press the key again when one of the probe-related labels "Pb1...Pb5" press the **set** key again. The value measured by the associated probe will appear on the display.

**NOTE:** The displayed value is read-only and cannot be modified.

### KDEPLUS BUTTONS

The **KDEPlus** keyboard has 4 keys, as shown in the illustration:



### KEY-ACTIVATED FUNCTIONS

All models have the **UP** key set to enable the "Manual Defrost" function.

The DOWN and ESC keys can also be set to activate any other function required by the user.

The parameters for configuring the two keys are:

- **H11** = DOWN key configuration
- **H33** = ESC key configuration

The values that can be set apply to both keys and the functions that can be activated are:

H32/H33 value	Function to enable
0	disabled
1	defrost
2	reduced set
3	Light
4	Energy saving
5	AUX
6	Stand-by
7	Deep cooling cycle
8	Start/end defrost

## MAINTENANCE

### **WARNING**

**To reduce the risk of fire, electrical shock or injury when cleaning this merchandiser:**

- **Unplug the merchandiser before cleaning;**
- **Keep all liquids away from electrical and electronic components;**
- **Do not use any mechanical device or other means to speed the defrost process, except as recommended by the manufacturer.**

### CARE AND CLEANING

Long life and satisfactory performance of any equipment is dependent upon the care it receives. To ensure long life, proper sanitation and minimum maintenance costs, this unit should be thoroughly cleaned, all debris removed and the interiors washed down. Cleaning often will control or eliminate odor buildup. Frequency of cleaning is dependent on usage and local health requirements.

### **WARNING**

**Do not use HOT water on COLD glass surfaces. This can cause the glass to shatter and could result in personal injury. Allow glass fronts, ends and service doors to warm before applying hot water.**

### Exterior Surfaces

The exterior surfaces must be cleaned with a mild detergent and warm water to protect and maintain their attractive finish.

**NEVER USE ABRASIVE CLEANERS OR SCOURING PADS. NEVER USE CAUSTIC SODA, KEROSENE, GASOLINE, THINNER, SOLVENTS, DETERGENTS, ACIDS, CHEMICALS OR ABRASIVES. DO NOT USE AMMONIA-BASED CLEANERS ON ACRYLIC PARTS.**

### Interior Surfaces

**DO NOT USE AMMONIA-BASED PRODUCTS TO CLEAN LIGHT SHIELDS. NEVER USE ABRASIVE CLEANSERS OR SCOURING PADS.**

The interior surfaces may be cleaned with most domestic detergents and sanitizing solutions with no harm to the surface. Always read and follow the manufacturer's instructions when using any cleaning product.

Inspect all LED connections and plug/receptacles for signs of arcing. Replace any component that shows signs of arcing. Make sure all unused receptacles have close-off covers securely attached.

### CLEANING UNDERNEATH THE CASE

The case can be moved to facilitate cleaning. Unplug the merchandiser, and move it out if the way in order to sweep and mop the area underneath the case. Brush away all dirt and litter from the area. Ensure there is no dirt build up around the bottom of the case or near the intake or exhaust.

## ***Do NOT Use:***

- Abrasive cleansers and scouring pads, as these will mar the finish.
- Coarse paper towels on coated glass.
- Ammonia-based cleaners on acrylic parts.
- A hose on lighted shelves or submerge the shelves in water.
- Solvent, oil or acidic based cleaners on any interior surfaces.
- A hose on rail lights, canopy lights or any other electrical connection.
- Rinse with hot water, but do NOT flood.
- Allow merchandiser to dry before resuming operation.
- Wipe down lighted shelves with a damp sponge or cloth so that water does not enter the light channel. **DO NOT USE A HOSE OR SUBMERGE SHELVES IN WATER.**
- After cleaning is completed, restore power and turn on the merchandiser.

## ***Do:***

- **First turn off refrigeration, then disconnect electrical power.**
- Remove product and loose debris.
- Thoroughly clean all surfaces with soap and hot water. **DO NOT USE STEAM OR HIGH WATER PRESSURE HOSES TO WASH THE INTERIOR. THESE DESTROY MERCHANDISER'S SEALING CAUSING LEAKS AND POOR PERFORMANCE.**
- Take care to minimize direct contact between fan motors and cleaning or rinse water.



## WARNING

Product will be degraded and may spoil if allowed to sit in a non-refrigerated area.

### Cleaning Shelves

Shelves and shelf clips are easily removed for cleaning the interior as well as the shelves themselves.

### Cleaning Condenser Coils

To maintain peak operating efficiency, the coil should be cleaned at least once each month. A dirty coil slows product cooling significantly and increases energy consumption by as much as 20%. Dirt buildup on coils can also cause the compressor to lock up damaging the condenser unit. All VRM models have the same access panel design for commonality between merchandisers.

1. Loosen screws at each side of the front bottom grille, then lift up and pull off the grille.



Front Grille

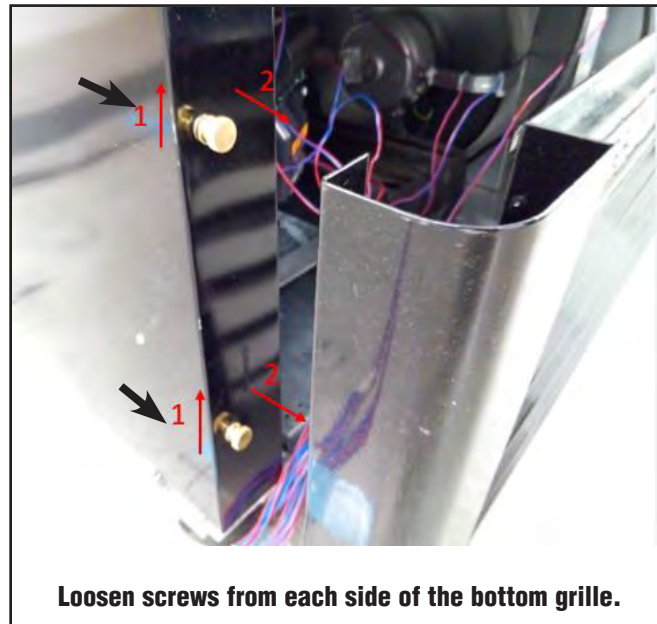

Loosen screws from each side of the bottom grille.

2. Next, detach the merchandiser's electrical wire harness.

3. Unscrew the stop bracket that holds the condensing unit to the rail base.

4. Grab the condensing unit from condensing unit handle.

**USE ONLY THE UNIT HANDLE TO PULL OUT THE REFRIGERATION SYSTEM. PULLING ON REFRIGERATION LINES OR OTHER PARTS WILL CAUSE DAMAGE TO THE REFRIGERATION UNIT.**

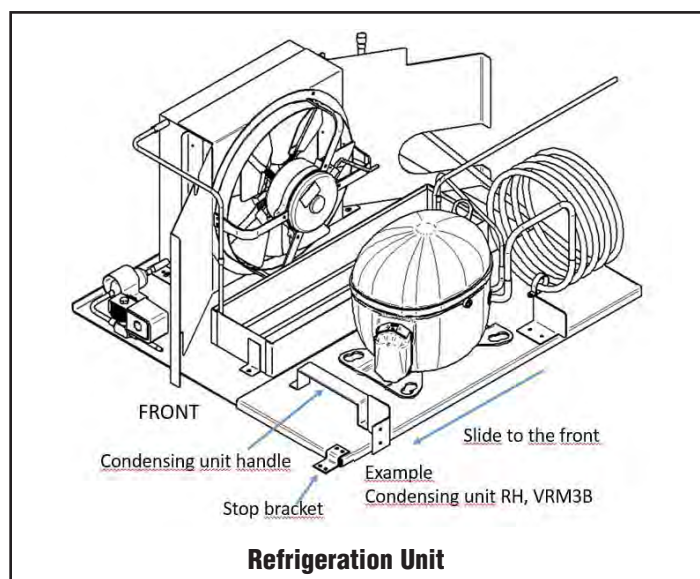

Refrigeration Unit

5. Use a soft hand brush attachment on a vacuum to remove accumulated dust and debris.

Consult an authorized service technician if more extensive cleaning is needed. If the refrigeration unit is damaged, it can be replaced with a new unit.

## TIPS AND TROUBLESHOOTING

There are a few simple things to check before calling for service:

1. Product not cold? Refrigeration unit requires 24 hours at initial startup to cool down to operating temperature with **NO PRODUCT LOADED** in merchandiser. Ask when merchandiser was stocked, and what the usage has been. It may take 30 minutes or more for product to chill following stocking.
2. Check the door and door seal for air leaks.
3. Power Supply:
  - Is the unit plugged in?
  - Is there power to the unit?
4. Location
  - What are the ambient conditions—temperature and humidity, direct sun, nearby source of heat, such as oven or grill? Is the unit level? Has the unit been moved recently?
5. Shelves and Stocking
  - Are the standard shelves in the correct places?
  - Is the product stocked properly?
  - Is the bottom shelf at the proper location?
6. Confirm that the defrost schedule is properly set.

### IMPORTANT INFORMATION

**For prompt service** when contacting the factory, be sure to have the case model and serial number from the case serial plate.

## ! WARNING

### — LOCK OUT / TAG OUT —

**To avoid serious injury or death from electrical shock, always disconnect the electrical power at the main disconnect when servicing or replacing any electrical component. This includes, but is not limited to, such items as doors, lights, fans, heaters, and thermostats.**

## ADJUSTING CLOSING TORQUE

Adjust closing torque by turning the bottom hinge pin in the direction the door closes. Use a 1/2 in. (13 mm) wrench. Turn the hinge pin until the door closes on its own, usually to 2 clicks or 1/2 turn.

**DO NOT** over-torque the hinge spring assembly. Excessive torque (over 1 full turn) will result in damage to the spring assembly and/or door. If door does not close on its own after one full turn (5 clicks), look for obstructions causing the door to hang up.

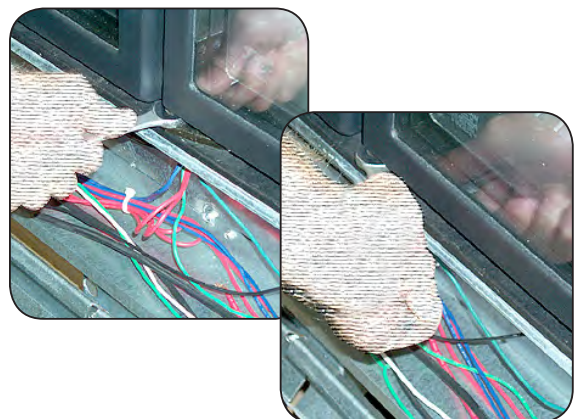

**Adjusting Closing Torque**

**ADJUSTING DOOR SAG**

To adjust door sag (saw-tooth effect from door to door), loosen the two hinge plate mounting screws using a Torx Plus no. 27 bit. Adjust hinge plate as needed, then tighten the screws.

**CONDITIONING GASKETS**

The manufacturer cannot control the environment surrounding cases during shipment. Temperature and humidity fluctuations during shipment, as well as excessive vibration, may promote gaps between gasket and frame. These gaps prevent gaskets from sealing even when correctly fitted at the factory.

This is not a warranty issue or defect.



**Adjusting Door Sag**

Follow this procedure to ensure gaps close and gaskets seal properly:

1. Remove all shipping retainers and all packing material.
2. Close each door. Use a flashlight to identify any gaps between frame and gasket.
3. Energize all anti-sweat, fan and light circuits for at least two hours, but not more than four hours, prior to initiating the refrigeration cycle.

4. Monitor all gaps. If gaps remain at the end of four hours, follow the procedure for Restoring Gasket Seal, beginning on page 6 of this manual.

5. Initiate cooling sequence once gaps disappear.

Do not exceed 8 hours of energized circuits without refrigeration. Doing so may cause damage to the case and will void the warranty.

**ATTENTION**

TO ENSURE PROPER DOOR GASKET SEAL - REMOVE ALL SHIPPING RETAINERS AND ENERGIZE ALL ANTI-SWEAT, FAN & LIGHT CIRCUITS 2 TO 4 HOURS PRIOR TO INITIATING REFRIGERATION CYCLE.

**DO NOT EXCEED 8 HOURS OF ENERGIZED CIRCUITS WITHOUT REFRIGERATION. DAMAGE OR PRODUCT FAILURE MAY OCCUR AND VOID THE WARRANTY.**

**DO NOT REMOVE THIS LABEL UNTIL REFRIGERATION IS INITIATED.**

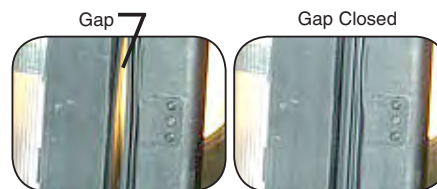

**Before and After Gasket Conditioning**

## INNOVATOR DOOR MAINTENANCE

As part of an ongoing maintenance program for Innovator Doors, Hussmann recommends that the items below be checked annually.

- a) Proper door closing torque
- b) Gasket performance (check for tearing and proper sealing)
- c) Check the top hinge pin to ensure the pin is properly seated and not bent
- d) Check the bottom hinge plate for excessive wear (worn cam teeth)
- e) Proper operation of hold open brackets

### 1. Check the doors for proper closing torque:

Test 1: Open door 90 degrees and close it manually. Make sure the door opens and closes without binding

Test 2: Open door 90 degrees and release it. The door should close on its own

Test 3: Open door more than 3” but less than 6” and release it. The door should close on its own.

Torque adjustment, if needed, should be performed “one click” at a time. A “zero” torque door should not require more than 4 clicks. If the torque cam and hinge socket are severely rusted, both components should be replaced. A severely rusted cam / socket assembly will not hold torque. Rust on the cam socket assembly is usually caused by one of the following:

- High humidity conditions > ASHRAE Type I
- Cycling of the frame heaters

Note 1: A rusted torque cam / socket assembly can cause excessive wear on the torque rod’s spacer and sleeve bearing. The result is a door that can “seat” farther down the rod assembly to the point that it causes binding at the hold open bracket. It can also cause the top hinge pin’s sleeve bearing to deform.

If the door is seated too far down the torque rod assembly, it most likely damaged the top hinge pin sleeve bearing. If the pin is not bent, replacing the pin’s nylon sleeve bearing will be sufficient. Although the torque rod assembly’s sleeve bearing and spacer are replaceable, we recommend that a severely rusted torque rod assembly be replaced.

### 2) Inspect door gaskets:

- Check for tearing gaskets
- Make sure the gasket’s dart is properly seated into the door’s gasket groove.

### 3) Inspect the top hinge assembly for excessive movement at the top hinge socket.

- By design, the door will have a small, but discernible amount of movement at the top hinge pin / hinge plate socket joint. If excessive movement is detected, the hinge pin assembly should be inspected to ensure that the hinge pin is not bent (refer to note #1)

### 4) Inspect hold open bracket:

- Open the door to the “hold open” engagement position. The “hold open” bracket should retain the door.
- If the bracket fails to retain the door, replace the bracket and the shoulder screw.

5) If a door passes the three “open / close” tests, and there is no excessive movement at the top hinge pin, then it is highly unlikely that any components require replacement.



Self-Contained Refrigeration Equipment Maintenance Check List

\*\*\*\*\* Warranty does not cover issues caused by improper installation or lack of basic preventative maintenance. \*\*\*\*\*

Record starting date	
Store Name and Number	
Store Address	
Unit Model Number	
Unit Serial Number	
Contractor/Technician	

	Technician		Q1	Q2	Q3	Q4	Q1	Q2	Q3	Q4
	Quarterly	Semi-Annually								
PM activity-For visual inspection items, denote "ok or complete" in the column to right when PM has been performed. For measured data requested, record data requested in the appropriate column to the right)										
Check in with store manager, record any complaints or issues they have with unit.	X									
Look unit over for any damage, vibrations or abnormal noise.	X									
Verify unit is level side to side and front to rear.	X									
Confirm refrigerant lines properly are secured and not touching or rubbing other lines, wires or frame work.	X									
Verify fan motors and motor mounts are tight.	X									
Confirm fan blade/s are tight and not rubbing or hitting.	X									
Make sure all electrical connections, factory and field, are tight.	X									
Verify electrical connections at lamps are they secure and dry.	X									
Check for and replace any frayed or chaffed wiring.	X									
Check all electrical wiring make sure it is secured and not on any sharp edges or hot lines.	X									
Check for air disturbances external to the unit. Heat and air registers, fans, and doors etc.	X									
Check for water leaks.	X									
Clean evaporator coil/s and fan blade/s. Do not use an acid base cleaner. Rinse off any cleaner residue.		X								
Clean discharge air honeycombs or grilles. Do not use an acid base cleaner. Rinse off any cleaner residue.		X								
Clean condenser coil/s and fan blade/s. Do not use an acid base Cleaner. Rinse off any cleaner residue.		X								
Clean condensate drain pan and drain line.		X								
Verify condensate drain lines are clear and functioning.		X								
Record voltage reading at unit with unit off?		X								
Verify condenser and evaporator fans are working.	X									
Record condenser air inlet temperature	X									
Record condenser air outlet temperature	X									
Is condenser air inlet or air exhaust restricted or recirculating?	X									
Use a handheld propane leak detector ("sniffer") to check for refrigerant leaks.	X									
Record voltage reading with unit running.		X								
Record compressor amp draw.		X								
Record defrost heater voltage and amp draw.		X								
Record anti-sweat heater voltage and amp draw.		X								
Record case product temperature.	X									
Record unit discharge air temperature.	X									
Record unit return air temperature.	X									
Record ambient conditions around unit (wet Bulb temperature and dry bulb temperature).	X									
Check product loading, do not load beyond the units load limits.	X									
Verify clearances on sides/back of unit.	X									
Check unit controller for proper operation. See controller or 1/0 Manual for proper controller operation.		X								
Confirm door switches function.	X									
Verify unit doors and lids work and are sealed correctly.	X									
Verify that all the panels, shields and covers are in place.	X									

Technician Notes:



*NOTES:*

**REPLACING DISPLAY LAMP**

1. Disconnect power to the merchandiser. Remove the screws at the top of the unit display.
2. Remove the top panel.

**Display Slides out to access Wireway**

3. Remove the merchandiser's plexiglass panel.

**LED and Power Supply Shown**

4. Replace the LED with like fixture, and re-attach connection.
5. Return power to the merchandiser.

**SERVICE****REPLACING SHELF LAMPS**

1. Disconnect power to the merchandiser. The LED fixtures are located behind the top of the door frame.

**LED Location**

2. Remove the screws and disconnect the LED fixture from the merchandiser.



3. Replace the LED with like fixture.



4. Return power to the merchandiser.

## FRAME HEATER REPLACEMENT

Always turn off power to the case before working on any electrical components. The old wireway covers must be removed to access the door frame heaters. Begin by inserting a putty knife into the groove between the wireway cover and fiberglass frame, about an inch (25 mm) away from joints in the frame as shown. Carefully begin to pry off the cover.

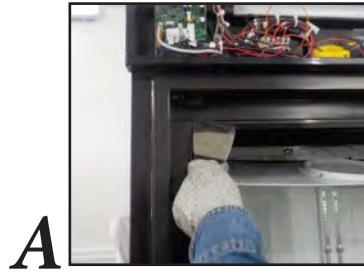

Use a second putty knife or flat head screwdriver to hold up the cover as shown in **A**. Pry the remainder of the section up, using putty knife only, until the entire cover is off and the frame heater inside the door frame is exposed as shown in **B**.

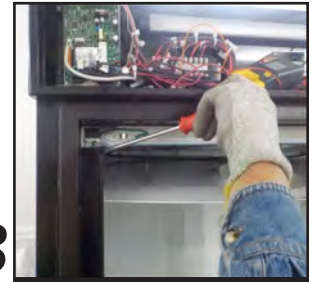

Door frame heaters may now be replaced.

During installation, the white portion of the heater should not come in contact with itself. The heater should be installed so that only one white portion of the wire enters the raceway. The other portion entering the raceway will be the black lead wire.



Once the heater wire is connected, check resistance (ohm reading) before replacing wireway covers. This will ensure that heater wire was not broken during installation. Wiring diagrams are shown on the last pages of this manual.



After covers are reinstalled, turn power on and verify that heaters are working properly.



## Technical Data

## Visual Description of R290 Replacement Parts



Main Switch



Light Switch



Solid State Relay 25 Amp



Control RTN400



Control Display KDE

**WARNING**

**Component parts are specifically chosen for propane exposure and therefore non-incendive and non-sparking. Component parts shall be replaced with identical components, and servicing shall be done by factory authorized service personnel only, so as to minimize the risk of possible ignition due to incorrect parts or improper service.**

## VRM Replacement Parts List

### Models

#### Standard Parts

Description	Part Number	VRM1B	VRM2B	VRM3B
Power Cord (NEMA 5-15P)	0521094	X	X	X
Light Switch	3038707	X	X	X
Sensor NTC 4 mts Green	3023554	X	X	X
Sensor NTC 4 mts Orange	3031571	X	X	X
Control Eliwell RTN400	3023537	X	X	X
Control Display KDE	3023552	X	X	X
Main Switch	3038707	X	X	X
Solid State Relay 10 Amp	3025471	X	X	X
Rail-Shelf (50")	3015493	X	X	X
Shelf Clips (insert into Rail-Shelf)	3009285	X	X	X
Wire Shelf (White) 21 X 24.312	3015794		X	X
Wire Shelf Bottom (White) 21 X 24.312	3015795		X	X
Wire Shelf (White) 21 X 24.812	3041925	X		
Wire Shelf Bottom (White) 21 X 24.812	3041926	X		
Led Light CTR 4000K	3024564	X	X	
Led Light RH 4000K	3024573		X	X
Door Black Med Temp LH	3025860	X	X	X
Door Torsion Door Assy	3017256	X	X	X
Door Gasket	3017271	X	X	X
Door Handle	051007300	X	X	X

#### Upper Lighted Display

Description	Part Number	VRM1B	VRM2B	VRM3B
White Plexiglass Display 1 Doors	3041296	X		
White Plexiglass Display 2 Doors	3020063		X	
White Plexiglass Display 3 Doors	3016789			X
Power Supply 100W 24VDC	3013744	X	X	X
Led tube 21.8" Display	3083166	X		
Led tube 45.8" Display	3083187		X	
Led tube 69.8" Display	3083188			X
Led display bracket	3084764	X	X	X

### WARNING

**Component parts are specifically chosen for propane exposure and therefore non-incendive and non-sparkling. Component parts shall be replaced with identical components, and servicing shall be done by factory authorized service personnel only, so as to minimize the risk of possible ignition due to incorrect parts or improper service.**

## VRM Replacement Parts List (Continued)

Refrigeration	Part Number	VRM1B	VRM2B	VRM3B
Condenser Unit Assy VRM1B	3084417	X		
Condenser Unit Assy VRM2B	3085573		X	
Condenser Unit Assy VRM3B	3085120			X
Compressor R290 115V/60Hz 1/4 HP	3024061	X	X	X
Condenser VRM1B	3083538	X		
Condenser VRM2B	3083539		X	
Condenser VRM3B	3083540			X
Condenser Fan Motor Assy 10.3" (Motor, Blade & Brkt)	3050263	X	X	X
Evaporator Coil VRM1B	3083543	X		
Evaporator Coil VRM2B	3083544		X	
Evaporator Coil VRM3B	3083545			X
Evaporator Fan Motor 1200 RPM	3055126	X	X	X
Evaporator Fan Blade 8.25"	3055130		X	X
Evaporator Fan Blade 7.00"	3055131	X		
Evaporator Fan Motor Bracket	3058806	X		
Evaporator Fan Motor Bracket 8.25"	3085277		X	X
Capillary Tube .045" x 120"	3084852	X		
Capillary Tube .049" x 195"	3020535		X	X
Filter Drier 704-200	0530462	X	X	X

Heaters	Part Number	VRM1B	VRM2B	VRM3B
Heater Frame 115V VRM1B	3037337	X		
Heater Frame 115V VRM2B	3022285		X	
Heater Frame 115V VRM3B	3022286			X

Sheet Metal Replacement Parts Painted	Part Number	VRM1B	VRM2B	VRM3B
Support Post Rear Panel	3023820		X	
Support Post Rear Panel	3015489			X
Support Post Shelf	3015492		X	X
Pan Assy-Evap MDM 1 Door	3084524	X		
Pan Assy-Evap MDM 2 Door	3085644		X	
Pan Assy-Evap MDM 3 Door	3085205			X
Front Grill Assy 1 Doors	3041170	X		
Front Grill Assy 2 Doors	3018400		X	
Front Grill Assy 3 Doors	3016857			X
Ext Rear Bottom Panel 1 Doors	3041401	X		
Ext Rear Bottom Panel 2 Doors	3020018		X	
Ext Rear Bottom Panel 3 Doors	3015027			X

### **WARNING**

**Component parts are specifically chosen for propane exposure and therefore non-incendive and non-sparking. Component parts shall be replaced with identical components, and servicing shall be done by factory authorized service personnel only, so as to minimize the risk of possible ignition due to incorrect parts or improper service.**

**Dimensions**

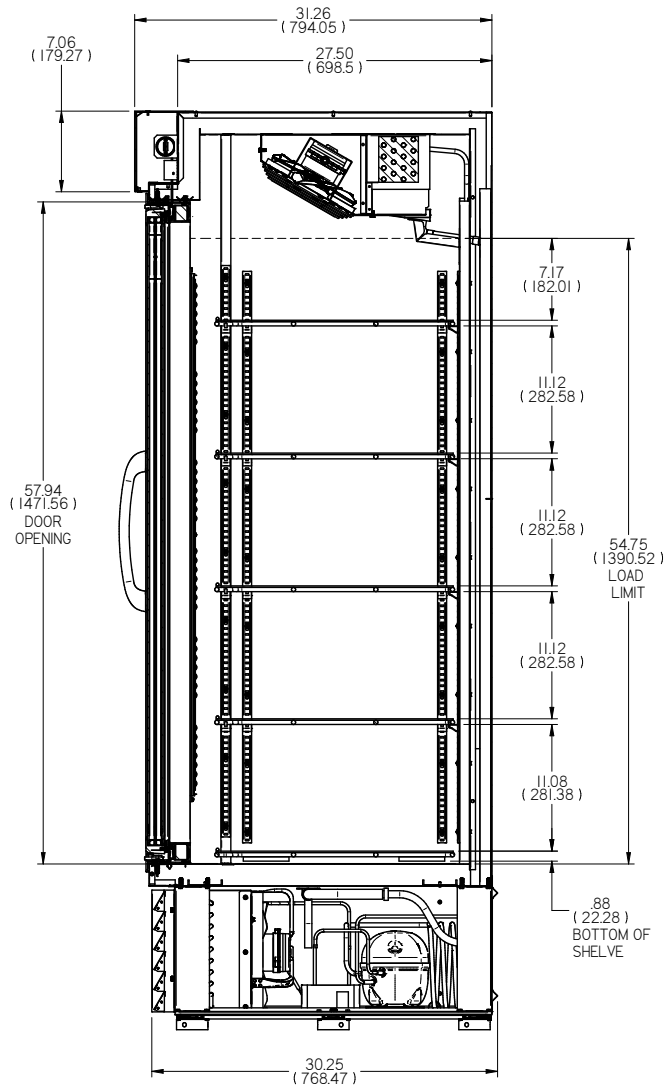

**VRM Cross Section Dimensions shown as inches and (mm).**

**Dimensions**

Model	Doors	Refrig.	Cu. Ft. Capacity
VRM1B	1	R-290	23.3
VRM2B	2	R-290	45.1
VRM3B	3	R-290	67.2

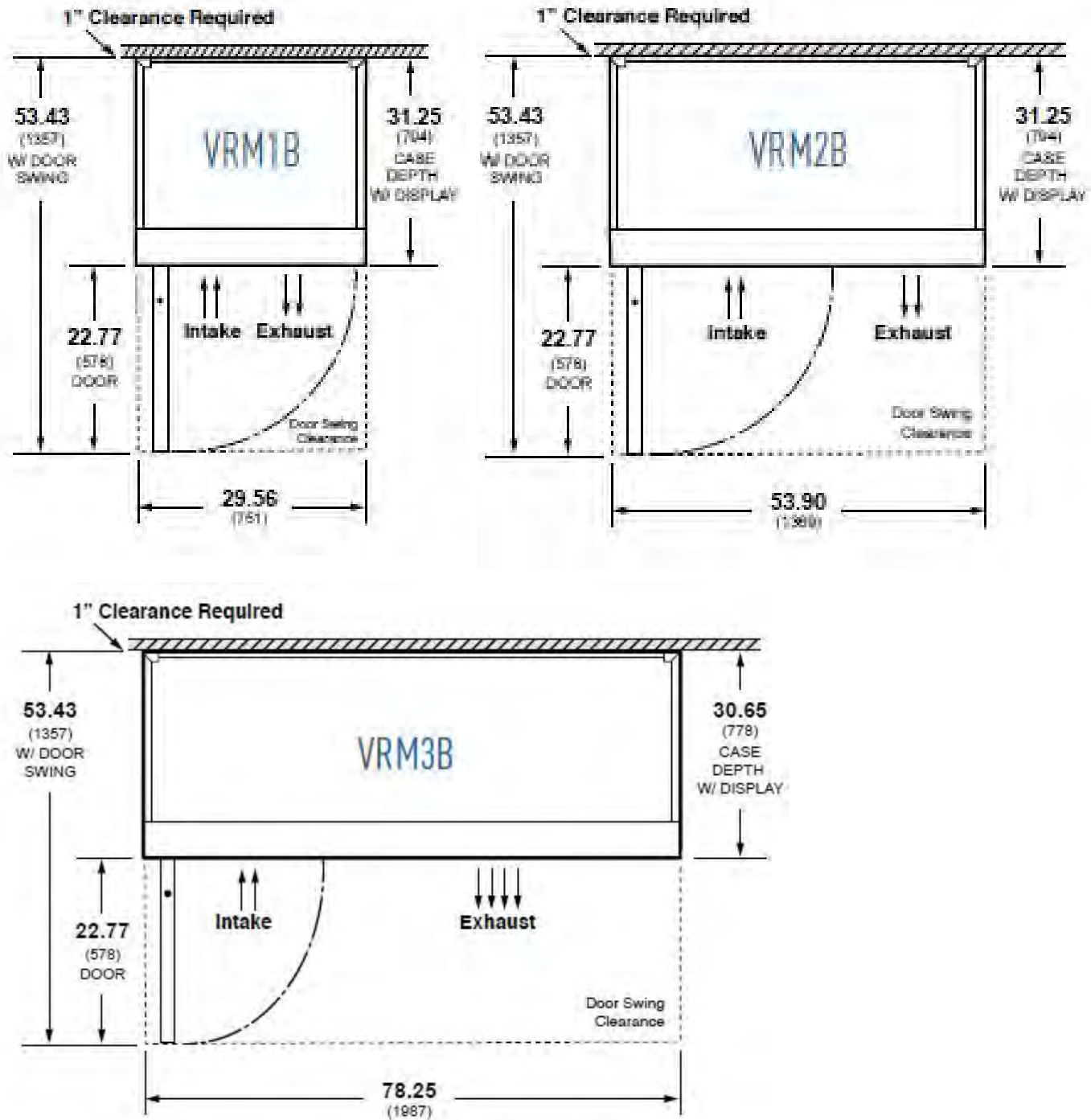

**VRM Plan View Dimensions shown as inches and (mm).**



**Electrical Data**

**DEFROST DATA**

Frequency (hr) 12

**OFF-TIME DEFROST**

**PHYSICAL DATA**

**Refrigerant Charge (R290)**

VRM1B 2.8 oz 0.080 kg (1 system)  
 VRM2B 5.3 oz 0.150 kg (1 system)  
 VRM3B 5.3 oz 0.150 kg (1 system)

**Note:** This data is based on store temperature and humidity that does not exceed 80°F and 55% R.H. unless otherwise stated. Schedule defrost at night while lights are off.

**Electrical**

Model	Nom. HP	Hz/Ph	Volts	Run Amps	Fuse Amps	NEMA Plugs	Refrig. Load (BTU/h)	A/C Load (BTU/h)	Energy Consumption (kWh/day)	Approx. Ship Wt. (lbs)
VRM1B	1/4	60/1	115	2.2	15	5-15P	884	1160	2.86	352
VRM2B	1/4	60/1	115	2.5	15	5-15P	1700	2100	4.12	566
VRM3B	1/4	60/1	115	2.6	15	5-15P	1920	2490	6.33	782

**Evaporator Fans**

	VRM1B	VRM2B	VRM3B
Number of Motors	1	2	2
Amperes	0.13	0.26	0.26
Watts	16	32	32
Compressor LRA	14.9	14.9	14.9
Compressor RLA	2.85	2.85	2.85

# Wiring Diagram

ELECTRICAL SPECS  
 MODEL: VRM  
 VOLTAGE: 115 V  
 FREQUENCY: 60 HZ  
 W=WHITE  
 BK=BLACK  
 R=RED  
 BL=BLUE  
 BW=BROWN  
 ORN=ORANGE

WARNING  
 UNPLUG THE UNIT BEFORE SERVICING.

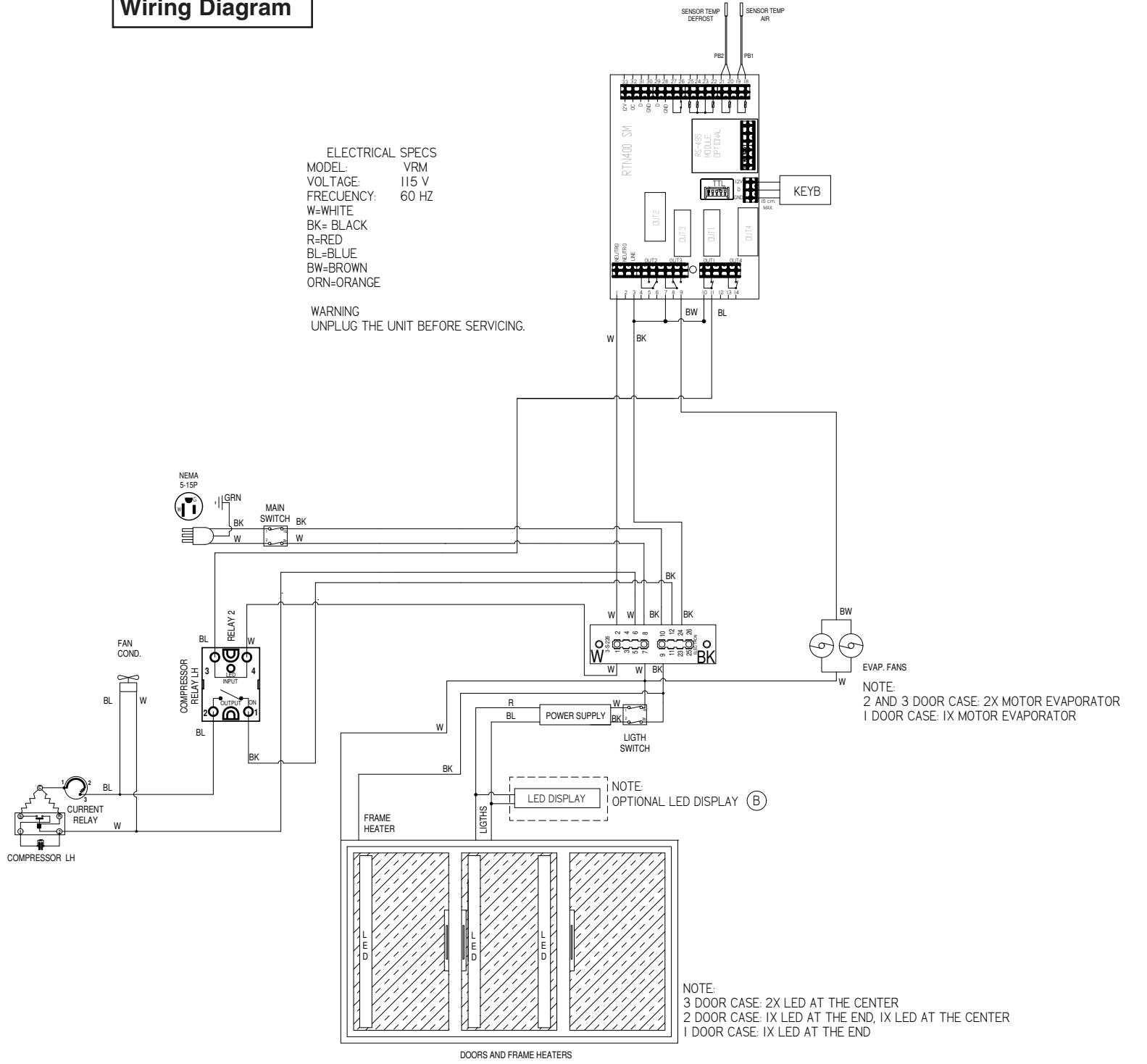

EVAP. FANS  
 NOTE:  
 2 AND 3 DOOR CASE: 2X MOTOR EVAPORATOR  
 1 DOOR CASE: 1X MOTOR EVAPORATOR

NOTE:  
 OPTIONAL LED DISPLAY (B)

NOTE:  
 3 DOOR CASE: 2X LED AT THE CENTER  
 2 DOOR CASE: 1X LED AT THE END, 1X LED AT THE CENTER  
 1 DOOR CASE: 1X LED AT THE END

## WARNING

All components must have mechanical ground, and the merchandiser must be grounded.  
 R = Red Y = Yellow G = Green BL = Blue BK = Black W = White B = Brown O = Orange GR = Grey

**Lighting Wiring Diagram**

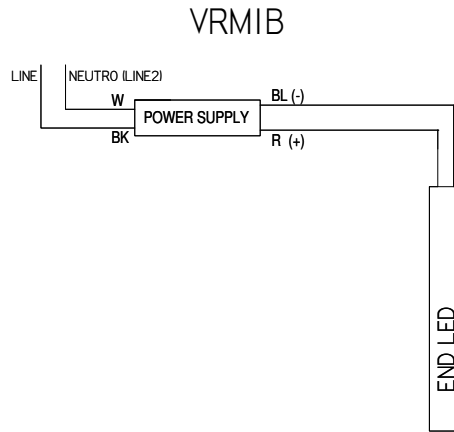
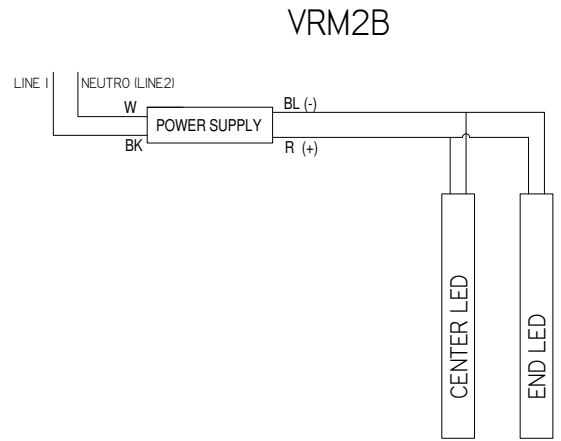
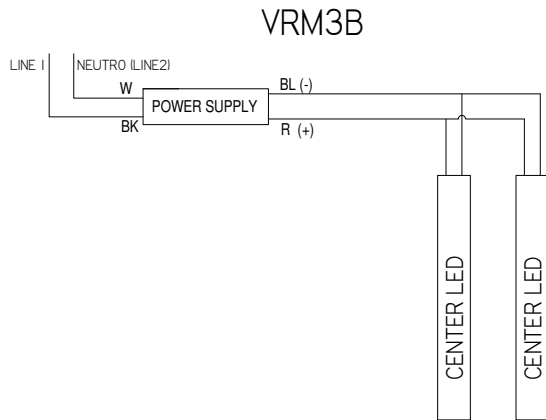



# **HUSSMANN<sup>®</sup>**

**To obtain warranty information  
or other support, contact your  
Husmann representative.  
Please include the model and  
serial number of the product.**

*Husmann Corporation, Corporate Headquarters: Bridgeton, Missouri, U.S.A. 63044-2483 01 October 2012*

**Husmann Corporation**

12999 St. Charles Rock Road  
Bridgeton, MO 63044-2483  
[www.husmann.com](http://www.husmann.com)