

HUSSMANN®



DOE 2017
Energy Efficiency
Compliant

MDN-4775A & MDN-3575A ***Medium Temperature*** ***Self Contained*** ***Open Vertical*** ***Merchandisers***



MDN-3575A
(shown)

Installation & ***Operation Manual***

IMPORTANT
Keep in store for
future reference!

ATTENTION

Merchandiser must operate for 24 hours
before loading product!

Regularly check merchandiser temperatures.

Do not break the cold chain. Keep products in cooler before
loading into merchandiser.

These merchandisers are designed for pre-chilled products
only.



IMPORTANT
KEEP IN STORE FOR FUTURE REFERENCE
Quality that sets industry standards!

12999 St. Charles Rock Road • Bridgeton, MO 63044-2483

U.S. & Canada 1-800-922-1919 • Mexico 01 800-890-2900

www.husmann.com

© 2018 Husmann Corporation

REVISION HISTORY

ORIGINAL ISSUE — APRIL 2018

Added Termination Temperature; Operating Pressures and Corrected Refrigerant Charge amount

ANSI Z535.5 DEFINITIONS



• **DANGER** – Indicate[s] a hazardous situation which, if not avoided, will result in death or serious injury.



• **WARNING** – Indicate[s] a hazardous situation which, if not avoided, could result in death or serious injury.



• **CAUTION** – Indicate[s] a hazardous situation which, if not avoided, could result in minor or moderate injury.

• **NOTICE** – *Not related to personal injury* – Indicates[s] situations, which if not avoided, could result in damage to equipment.

WARNING
This product may contain chemicals known to the State of California to cause cancer, birth defects, or other reproductive harm.

For California Businesses:

This warning is the result of the California State law known as the California Safe Drinking Water and Toxic Enforcement Act of 1986, which is commonly referred to as “Proposition 65.”

This warning does not mean that Hussmann products will cause cancer or reproductive harm, or is in violation of any product-safety standards or requirements. As clarified by the California State government, Proposition 65 can be considered more of a ‘right to know’ law than a pure product safety law. When used as designed, Hussmann believes that our products are not harmful. We provide the Proposition 65 warning to stay in compliance with California State law. It is your responsibility to provide accurate Proposition 65 warning labels to your customers when necessary. For more information on Proposition 65, please visit the California State government website.

Please make sure to read and follow all the Safety Precautions.



Refers to something you **MUST NOT** do.



Refers to something you **MUST** do.



In case of abnormalities or unit failure during operation, immediately stop use and unplug from outlet

<Danger of smoke, fire or electric shock>

Examples of abnormalities/unit failure

- You smell something burning or hear an abnormal noise.
- The power cord or plug becomes very hot.
- The unit is flooded in water
- You feel an electric current

- Please contact Hussmann immediately.



- This appliance is not intended for use by persons (including children) with reduced physical, sensory or mental capabilities, or lack of experience and knowledge, unless they have been given supervision or instruction concerning use of the appliance by a person responsible for their safety.
- Children should be supervised to ensure that they do not play with the appliance.



- The expected lifespan of the moisture wicking plates will differ in accordance with the operating environment, absorption will deteriorate with dust, oil, and other forms of soiling. The wicking plate should be replaced at least once per year.



Prohibition

■ About the power plug/cord

DO NOT

<Or may cause fire or electric shock>

- Do not damage, modify, bend, pull, twist or bundle the power plug/cord. Do not place a heavy item on the power plug/cord. Do not place the power plug/cord between heavy items.
- Do not remove the plug from the power supply with a wet hand.
- Do not hold the cord when removing the plug.
- Do not use an extension cord or a multi-plug connector.
- Do not use a damaged or loose power plug/cord.
- Do not stress the power cord plug when placing the unit against a wall



DO

<Or may cause fire or electric shock>

- Use only the supplied plug. (Single-phase 115V Frequency 60Hz).
- Use the correct wall connection for a NEMA L5-20P plug
- Remove the plug from the power supply socket before cleaning or repair.
- Wipe away any dust attached to the power plug/cord on a regular basis.
- Insert the plug securely.

⚠ WARNING

■ Electrical work



Contact a licensed service provider.

- Electrical work includes :
 - Installation of a high-speed electric leakage breaker.
 - Installation of a breaker for wiring.
 - Installation of dedicated socket with a ground.
 - Make sure to complete grounding work for any grounded outlet.
 - Follow all appropriate standards, laws and regulations regarding electrical installation
- (Failure may cause a fire or electric power leakage.)

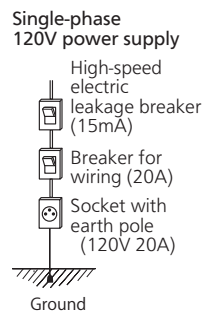

■ Installation



DO NOT

Prohibition

- <Or may cause electric shock or leak>
- Do not use the merchandiser outdoors.
 - Do not install the merchandiser in a place where it can easily come into contact with water



DO

- <Or may cause fire or electric shock>
- Contact a licensed service provider for installation service.
- <Or may cause injury>
- Place the product securely on a strong and level floor.
 - Take necessary measures to prevent the merchandiser from tipping over.



Prohibition

■ During use

DO NOT

<Or may cause fire, electric shock or injury>

- Do not store explosive substances such as aerosol cans with a flammable propellant in this merchandiser.
- Do not use a flammable spray near the merchandiser or put any flammable items on the merchandiser.
- Do not spray water outside or inside the merchandiser directly, and do not wash the merchandiser with water.
- Do not touch the control panel with a wet hand.
- Never disassemble, repair or reconfigure the product.
- Do not insert any screws into the surface of the merchandiser
- Never insert fingers, sticks, etc. into the cold air outlet, cold air inlet, air intake opening, air discharge opening, or any moving parts.

<Or may cause injury due to collapse, tipping, or damage of the unit>

- Do not step on the unit.
- Do not place anything on the unit.

<Or may cause flame or explosion>

- Do not use any electric appliances inside the merchandiser.

<Risk of damage to health>

- Never keep any medicines in the merchandiser.



DO

<Or may cause flame or explosion>

- Use the unit only to display and merchandise food and beverages. (Use for other purposes could result in a deterioration in quality of the displayed merchandise)
- In the event of a gas leak, open a window for ventilation, and do not touch the unit or electrical plug.



WARNING

■ Maintenance, service and check up



Prohibition

DO NOT

<Or may cause electric shock>

- Do not clean the machine compartment.
- Do not clean the water-drainage channel.
- Do not replace or inspect the LED lights.
- Do not clean the moisture-wicking plates



DO

<Or may cause electric shock>

- Contact a licensed service provider to clean the machine compartment and/or water-drainage channel.

For details, please contact Hussmann Customer Service

■ Storage and disposal



DO

<Or may cause electric power leakage and/or electric shock>

- Keep the product away from rainwater.
- Empty the overflow drain pan completely when removed.
- Contact a licensed service provider for disposal of the merchandiser.

For details, please contact Hussmann Customer Service



CAUTION

■ During use



Prohibition

DO NOT

- Do not throw products into the merchandiser.
- Do not put hands, apply strong force /impact, or throw products against the glass surfaces.
- Do not place any items that exceed the specified weight onto the shelves. (Refer to Page 10)
- Do not overload the shelves with product
- Do not let the nightshade go until it has been securely fastened, or rolled up.



DO

- Install the shelf as directed in this manual.

■ Installation, relocation and storage



Prohibition

DO NOT

- Do not apply strong force against, or impact the glass surfaces when moving the merchandiser.



DO

- Unplug the merchandiser and empty the accumulated water from the overflow drain pan before moving and/or storing.
- Be sure to wear appropriate personal protection equipment (PPE) when installing or moving the merchandiser.
- Remove all products and shelving from the merchandiser prior to moving.
- Contact Hussmann Customer Service for assistance when relocating the merchandiser.

INSTALLATION

UL LISTING

These merchandisers are manufactured to meet ANSI/ UL 471 standard requirements for safety. Proper installation is required to maintain the listing.

FEDERAL / STATE REGULATION

These merchandisers at the time they are manufactured, meet all federal and state/ provincial regulations. Proper installation is required to ensure these standards are maintained. Near the serial plate, each merchandiser carries a label identifying the environment for which the merchandiser was designed for use.

ANSI/NSF-7 Type I – Display Refrigerator / Freezer

Intended for 75°F (24°C) / 55%RH Ambient Application

ANSI/NSF-7 Type II – Display Refrigerator / Freezer

Intended for 80°F / 55%RH Ambient Application

ANSI/NSF-7 – Display Refrigerator
Intended for Bulk Produce

HUSSMANN PRODUCT CONTROL

The serial number and shipping date of all equipment is recorded in Hussmann's files for warranty and replacement part purposes. All correspondence pertaining to warranty or parts ordering must include the serial number of each piece of equipment involved. This is to ensure the customer is provided with the correct parts.

SHIPPING DAMAGE

All equipment should be thoroughly examined for shipping damage before and during unloading. This equipment has been carefully

inspected at our factory. Any claim for loss or damage must be made to the carrier. The carrier will provide any necessary inspection reports and/or claim forms.

Apparent Loss or Damage

If there is an obvious loss or damage, it must be noted on the freight bill or express receipt and signed by the carrier's agent; otherwise, carrier may refuse claim.

Concealed Loss or Damage

When loss or damage is not apparent until after equipment is uncrated, retain all packing materials and submit a written response to the carrier for inspection within 15 days.

Recommended operating ambient temperature is between 60°F (16°C) to 80°F (27°C). Maximum relative humidity is 55%.

LOCATION

These merchandisers are designed for displaying products in air conditioned stores where temperature is maintained at or below the ANSI / NSF-7 Type II specified level and relative humidity is maintained at or below 55%. Placing refrigerated merchandisers in direct sunlight, near hot tables or near other heat sources could impair their efficiency. Like other merchandisers, these merchandisers are sensitive to air disturbances. Air currents passing around merchandisers will seriously impair their operation. Do NOT allow air conditioning, electric fans, open doors or windows, etc. to create air currents around the merchandiser. If case operates in an environment outside of recommended temperatures, case performance will be affected.

Part names

Model MDN-4775A shown

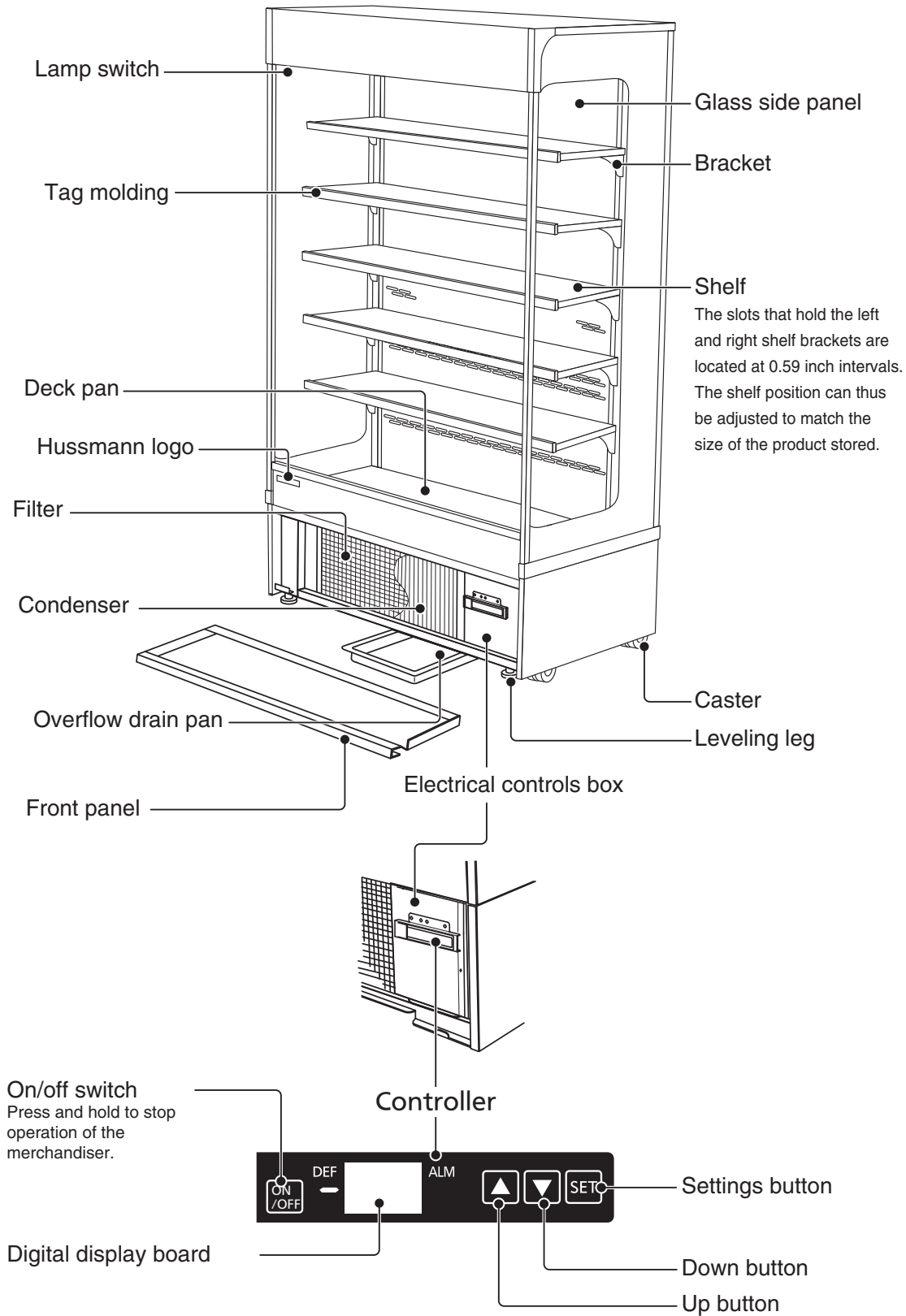

Part names

Model MDN-4775A shown

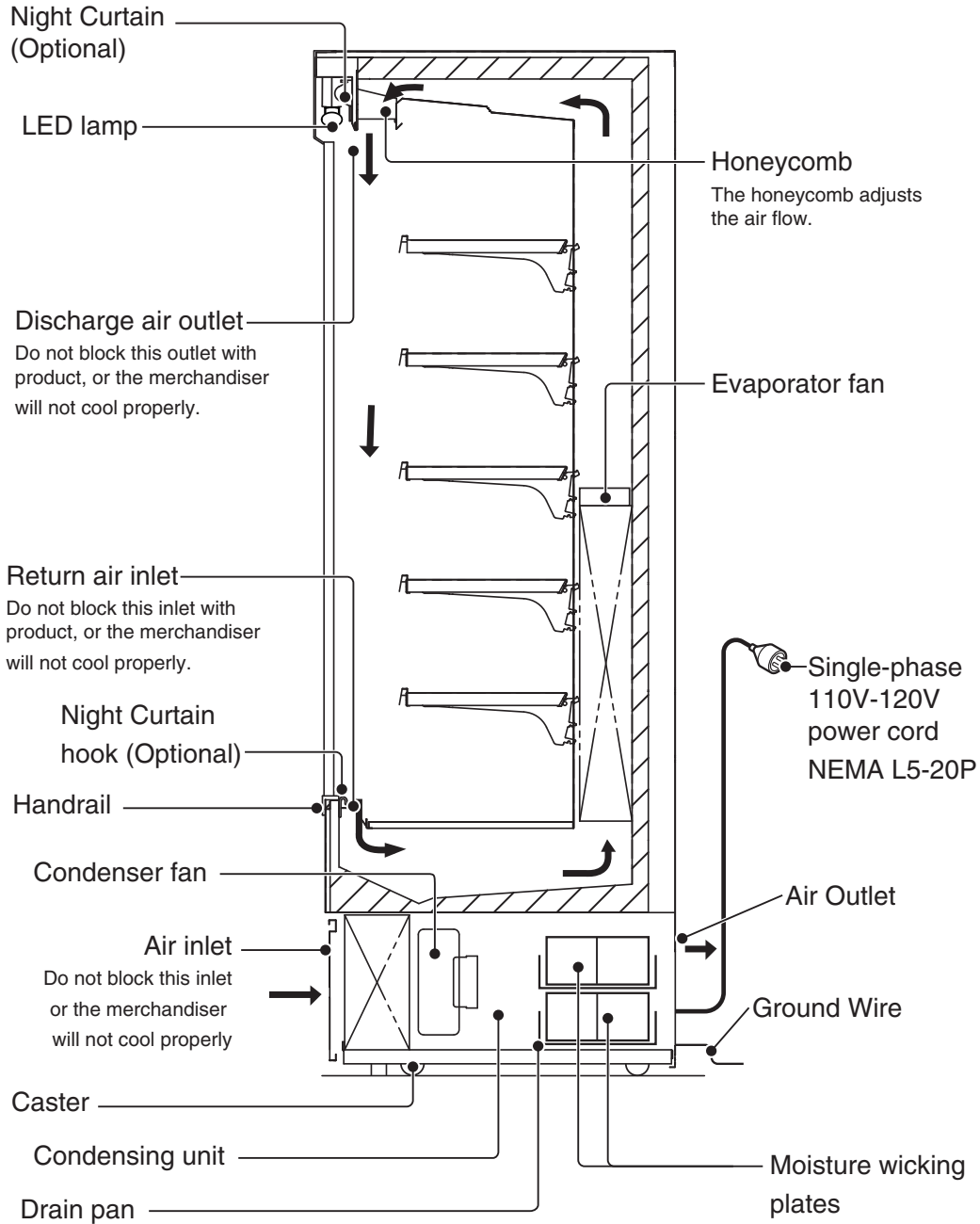

Additional parts

Name	Appearance	Quantity
Overflow drain pan		1
Thermometer		1

LOCATION

Product should always be maintained at proper temperature. This means that from the time the product is received, through storage, preparation and display, the temperature of the product must be controlled to maximize the life of the product.

BE SURE TO POSITION SELF CONTAINED MERCHANDISERS PROPERLY.

SELF CONTAINED models have vented base panels to allow air circulation through the condensing unit.

Allow for a minimum of 6 inches of clearance from walls, merchandisers, and any other large objects near the merchandiser's vented base panels. A minimum space of 6 inches should be left above the case. Blocking or restricting air flow will adversely affect performance and may damage the refrigeration system.

If the merchandiser is used or stored in a hot spring or coastal area, it may be damaged (due to sulfur or salt). If the intention is to install the merchandiser in any of the above areas or locations, contact the supplier or dealer where you purchased the merchandiser. Do not lay the case sideways to move the case. This may cause damage. Case should be installed on a flat, level floor.

After installation, fix the case in place with the leveling legs to make sure that it does not move.

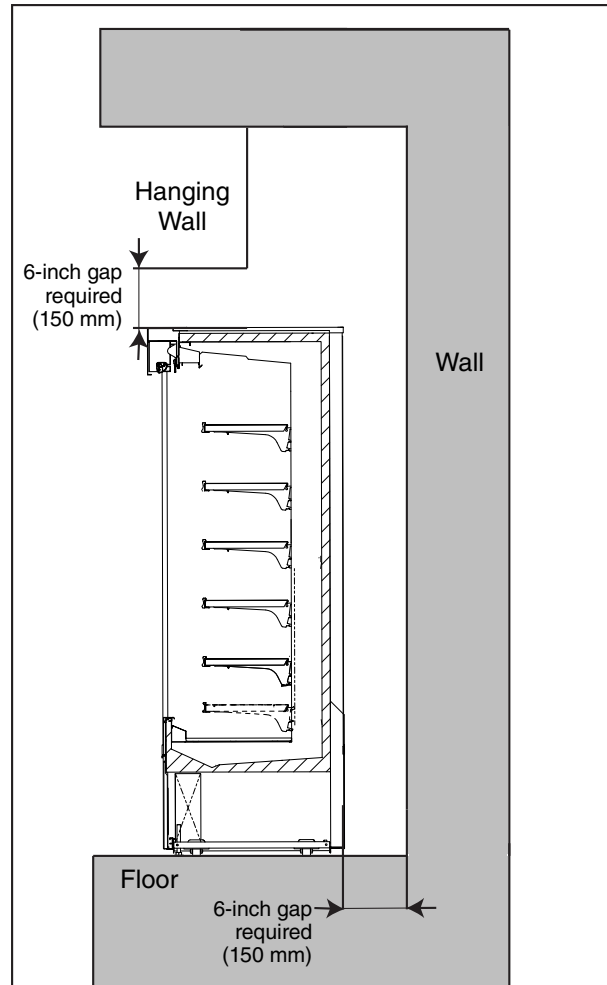
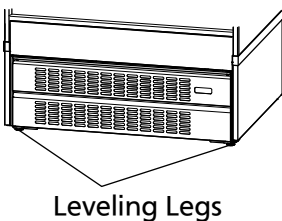

⚠ WARNING

Do not store items or flammable materials atop the unit.

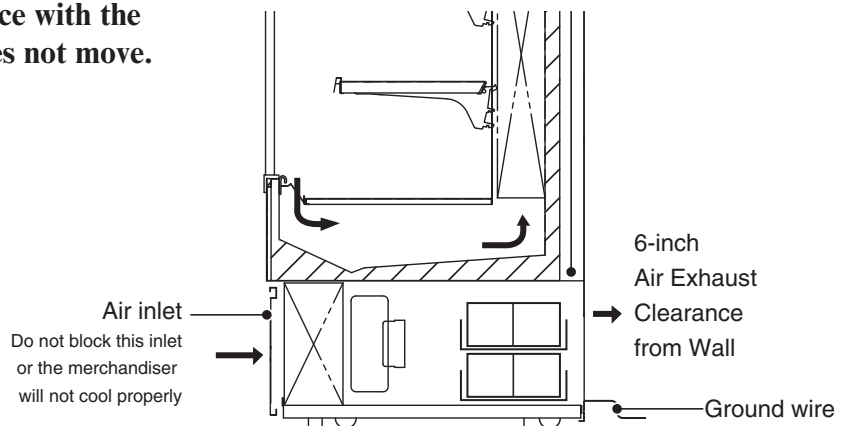

ELECTRICAL / REFRIGERATION

MERCHANDISER ELECTRICAL DATA

Refer to merchandiser serial plate for electrical information.

FIELD WIRING

Field wiring must be sized for component amperes stamped on the serial plate. Actual ampere draw may be less than specified.

ALWAYS CHECK THE SERIAL PLATE FOR COMPONENT AMPERES

ELECTRICAL CONNECTIONS

All wiring must be in compliance with NEC and local codes. Self contained models are electrical cord connected at the electrical box. Ensure ground pin is attached. For any questions, contact the supplier or dealer where you purchased the product or licenced service provider.

This unit uses a powercord with NEMA (L5-20P) plug. The powercord is rated for 20A/120V electrical.



L5-20R

! WARNING

Risk of Electric Shock. If cord or plug becomes damaged, replace only with a cord and plug of the same type.

ELECTRICAL OUTLET:

Before the merchandiser is connected to any wall circuit, use a voltmeter to check that the outlet is at 100% of the rated voltage. The wall circuit must be dedicated for the merchandiser. Failure to do so voids the warranty. **Do not use an extension cord.** Never plug in more than one merchandiser per electrical circuit.

- Always use a dedicated circuit with the amperage stated on the unit.
- Plug into an outlet designed for the plug.
- Do not overload the circuit
- Do not use long or thin extension cords. Never use adapters.
- If in doubt, call an electrician.

Ensure ground pin is attached.

For any questions, contact the supplier or dealer where you purchased the product or licenced service provider.

! WARNING

**Merchandiser must be grounded.
Do not remove the power supply cord ground.**

POWER SWITCH

The main ON/OFF switch is located on the front control on the bottom, righthand-side of merchandiser. This is not the main power switch. Power will continue to run through the case until main plug is unplugged.

REFRIGERATION**(Self Contained Models)**

Each self contained model is equipped with its own condensing unit and control panel located beneath the display area. The correct type of refrigerant will be stamped on each merchandiser's serial plate. The merchandiser refrigeration piping is leak tested. The unit is charged with refrigerant, and shipped from the factory with all service valves open.

WARNING

Refrigeration lines are under pressure. Refrigerant must be recovered before attempting any connection or repair.

CAUTION

When brazing pipes, be sure to use an insulation blanket (not shipped with the merchandiser) to prevent damage to the metal merchandiser bottom.

WATER OUTLET AND WATER SEAL

The condensate water outlet is located at the front of the liner bottom under deck pan. The outlet has a factory installed, external water seal.

For self contained models, this water seal drains into the condensate evaporator pan located beneath the merchandiser.

NOTE: All lower base panels must be in place when the refrigerator is operating. If not, air-flow from the condenser will be directed over the evaporator pan and defrost water in the pan may overflow.

WARNING

Product will be degraded and may spoil if allowed to sit in a non-refrigerated area.

WARNING

— LOCK OUT / TAG OUT —

To avoid serious injury or death from electrical shock, always disconnect the electrical power at the main disconnect when servicing or replacing any electrical component. This includes, but is not limited to, such items as doors, lights, fans, heaters, and thermostats.

CONTROLS AND ADJUSTMENTS

CONTROLS and ADJUSTMENTS

Refrigeration Controls					Defrost Controls			
Model	Product Application	Discharge Air Temperature	Discharge Air Temperature Cut In	Discharge Air Temperature Cut Out	Termination Temperature	Defrost Frequency (per day)	Type of Defrost	Failsafe Time (Minutes)
MDN	Medium Temp.	29°F (-1.7°C)	30°F (-1.1°C)	25°F (-3.9°C)	46.4°F (8°C)	12	Off Time	60

1. The controller controls refrigeration temperature. This is factory installed in the control panel mounted on the merchandiser's fascia. Measure discharge air temperatures at the center of the honeycomb.

Defrosts are time initiated and temperature terminated for self contained models. The defrost setting is factory set as shown above.



It is the contractor's responsibility to install merchandiser(s) in accordance with all local building and health codes.



WARNING

— LOCK OUT / TAG OUT —

To avoid serious injury or death from electrical shock, always disconnect the electrical power at the main disconnect when servicing or replacing any electrical component. This includes, but is not limited to, such items as doors, lights, fans, heaters, and thermostats.

REFRIGERATION LEVEL SETTINGS

Normally, please use refrigeration level 3 (proper temperature). (It is set at refrigeration level 3 at the time of shipment.)

The temperature inside the refrigerator can be adjusted with 9 levels of refrigeration level. The internal temperature varies depending on ambient conditions such as outside air temperature and humidity. Even if the refrigeration level is adjusted, the internal temperature of the product may not decrease, or the product may be too cold.

1. Set the internal temperature with the control panel in the electrical equipment box. Remove screws (2), then open the front panel.
2. Press the setting switch. "od" is displayed, and the setting mode of the internal temperature is entered.
3. Press the setting switch again to display the refrigeration level.
4. Press the ∇, Δ switch to adjust the desired refrigeration level.

5. Press the setting switch. The changed setting value is memorized, and the display returns to the display of internal temperature.

NOTE:

The user has one minute to press the setpoint button to confirm the new setpoint selection. If the user does not press the setpoint with one minute, the original setpoint will be returned, and the user will have to start back at Step 1 to they want to make a change to the setpoint.

Refrigeration level	temperature inside
1 Level max	LOW
2	
3	Proper temperature (at the time of shipment)
4	
5	
6	
7	
8	
9	High

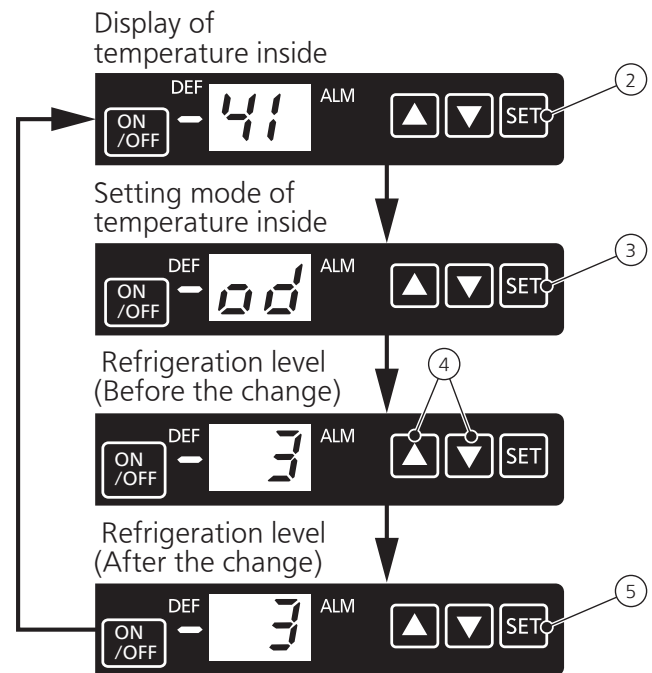

CONTROLLER INDICATION SYMBOL

The symbol indicating the internal temperature and operation condition is displayed on the digital displayed board. Please take the following measures when the following symbol is displayed. If the condition is not improved after taking the following measures, please contact the dealer where you purchased the product or customer service center.

This product has been designed to keep products at chilled temperature, and not to make warm products cold.

Make sure to place and display only pre-chilled items.

Follow the first-in, first-out rule to ensure quality of items.

Do not block the discharge air outlet and return air inlet with products.

SHELVES

Shelves should be loaded so that the product does not extend over the front edge of the shelf. Product loaded over the edge will interfere with air circulation in the cabinet.

Display items in such a way that will not protrude from the shelf / deck pan.

Display the items uniformly on shelf / deck pan.

Do not place items more than 155 lbs on deck pan and shelf.

After removing the items, adjust the height and angle of the shelf.

Adjust height and angle according to the product. The shelf height can be adjusted at 0.59 inch intervals.

Change the angle of the shelf with the hook as the fulcrum.

Indication symbol	Cause	Measures
<i>FL</i>	Clogged filter	Refer to "When "FL" flashes and displays on the digital display board", on Page 3-2.
<i>EH</i> / The internal temperature blinks	The internal temperature rises	Refer to "The case cannot get cold at all", "The case is not cold enough", on Page 4-2.
<i>EL</i> / The internal temperature blinks	The internal temperature gets too cold	Check the outdoor temperature, contact the dealer where you purchased the merchandiser or customer service center.
<i>H1 ~ Hb, L1 ~ Lb</i>	Failed sensor	Please contact the dealer where you purchased the merchandiser or customer service center.
<i>EO ~ EG</i>	Other trouble	
<i>dF</i>	Defrosting	Unnecessary (Finishing to defrost, the display of "dF" ends.)
<i>≡</i>	Shutdown	Unnecessary

STOCKING

Product should NOT be placed inside the merchandisers until merchandisers are at proper operating temperature.

Allow merchandiser 24 hours to operate before loading product.

Proper rotation of product during stocking is necessary to prevent product loss. Always bring the oldest product to the front and set the newest to the back.

AIR DISCHARGE AND RETURN FLUES MUST REMAIN OPEN AND FREE OF OBSTRUCTION AT ALL TIMES to provide proper refrigeration and air curtain performance. Do not allow product, packages, signs, etc. to block the air inlet and air outlet. Do not use unapproved shelving, baskets, display racks, or any accessory that could hamper air curtain performance. Contact your Hussmann representative for more information.

THERMOMETER

The thermometer is located in the bottom front panel of the merchandiser. The reading is in F°.



WARNING

Product will be degraded and may spoil if allowed to sit in a non-refrigerated area.

DEFROST

It starts automatically by the controller. When the merchandiser defrosts, the digital display board displays “dF”.

DRAIN WATER

Since the evaporation mechanism is attached, drainage work is unnecessary if the outside air temperature is 80°F, the humidity is 55% RH, and the ambient wind speed is less than 47.2 FPM.

During the summer and on high-humidity days, check the overflow drain pan at the bottom of the case, and throw out any excess water.

To temporarily stop operation of the case: Press and hold the *ON/OFF* switch on controller for 5 seconds. The digital display board displays “E”, and stops the operation. In case of re-start, press and hold the *ON/OFF* switch again for more than 5 seconds.

RE-START

Leave the product in the case for at least 5 minutes before re-starting the case.

If the merchandiser is re-started immediately after stopping, the overload protection unit or a breaker for wiring may trip, or an excessive load may be applied to the compressor, which will result in failure.

For energy savings:

It is a waste of electricity to cool down more than necessary. **The efficiency will be improved if you do the maintenance of the filter frequently.**

Please turn off the lights at night and at the time of closing the store. When night curtains are provided, pull them down during off hours to enhance product quality.



CAUTION

Do NOT allow cleaning agent or cloth to contact food product.

MAINTENANCE

CARE AND CLEANING

Long life and satisfactory performance of any equipment is dependent upon the care it receives. To ensure long life, proper sanitation and minimum maintenance costs, these merchandisers should be thoroughly cleaned, all debris removed and the interiors washed down, weekly.

Exterior Surfaces

The exterior surfaces must be cleaned with a mild detergent and warm water to protect and maintain their attractive finish. **NEVER USE ABRASIVE CLEANSERS OR SCOURING PADS.**

Interior Surfaces

The interior surfaces may be cleaned with most domestic detergents, ammonia based cleaners and sanitizing solutions with no harm to the surface. Self contained models empty into a limited capacity drain pan, which will overflow if excess water is used in cleaning.

Do NOT Use:

- Abrasive cleansers and scouring pads, as these will mar the finish.
- Coarse paper towels on coated glass.
- Ammonia-based cleaners on acrylic parts.
- Solvent, oil or acidic based cleaners on any interior surfaces.
- Do not use high pressure water hoses.

Do:

- Remove the product and all loose debris to avoid clogging the waste outlet.

- Store product in a refrigerated area such as a cooler. Remove only as much product as can be taken to the cooler in a timely manner.
- Disconnect electrical power before cleaning.**
- Thoroughly clean all surfaces with soap and hot water.

DO NOT USE STEAM OR HIGH WATER PRESSURE HOSES TO WASH THE INTERIOR.

These will destroy the merchandisers' sealing causing leaks and poor performance.

- Take care to minimize direct contact between fan motors and cleaning or rinse water.
- Do NOT flood merchandiser with water.

NEVER INTRODUCE WATER FASTER THAN THE WASTE OUTLET CAN REMOVE IT.

- Allow merchandisers to dry before resuming operation.
- After cleaning is completed, turn on power to the merchandiser.

REMOVING SCRATCHES FROM (OPTIONAL) BUMPER

1. Use steel wool to smooth out the surface area of the bumper.
2. Clean area.
3. Apply vinyl or car wax and polish surface for a smooth glossy finish.

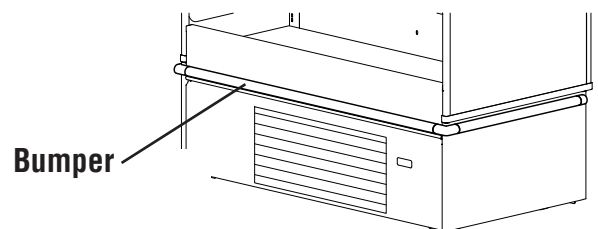

CLEANING STEEL SURFACES**(available only with stainless steel models)**

Use non-abrasive cleaning materials, and always polish with grain of the steel. Use warm water or add a mild detergent to the water and apply with a cloth. Always wipe rails dry after wetting.

Use alkaline chlorinated or non-chlorine containing cleaners such as window cleaners and mild detergents. Do not use cleaners containing salts as this may cause pitting and rusting of the steel finish. Do not use bleach.

CLEANING THE FILTER

Hussmann recommends cleaning the filter once a month, and even more often in environments with high dust or dirt.

Remove two screws, then front panel as shown in the illustration below. Hold the filter knob, and pull out the filter.

After the filter is removed, clean it with warm water or lukewarm water. Use neutral detergent if the filter is stained. Re-install the filter after it is dry.

If no filter is installed at all, the condenser will clog with dust and it will result in failure.

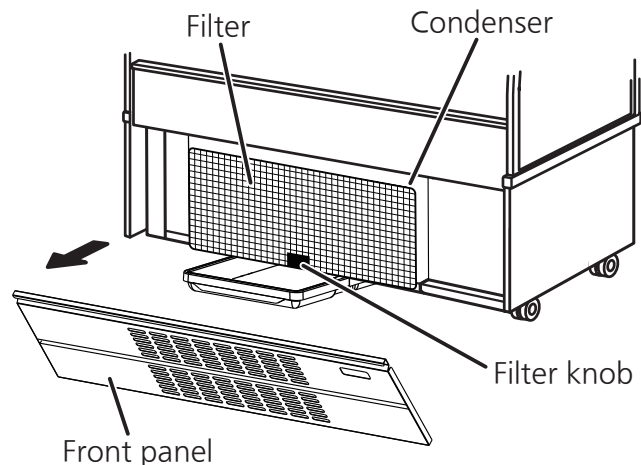
**CAUTION**

Shut Fans Off during cleaning process. Do NOT use HOT water on cold glass surfaces. This can cause the glass to shatter and could result in personal injury. Allow glass surface to warm before applying hot water.

**WARNING**

— LOCK OUT / TAG OUT —

To avoid serious injury or death from electrical shock, always disconnect the electrical power at the main disconnect when servicing or replacing any electrical component. This includes, but is not limited to, such items as doors, lights, fans, heaters, and thermostats.

**CAUTION**

DO NOT FLOOD!

Use only enough water necessary to clean surface. Water must not drip down the case!

Never use ammonia based cleansers, abrasive cleansers, or scouring pads.

CLEANING CONDENSOR COILS

Condenser coils should be cleaned at least once per month. Additional cleaning may be needed depending on the operational environment. A dirty condenser blocks normal airflow through the coils.

Airflow blockage increases energy consumption and reduces the merchandiser's ability to maintain operating temperature.

To clean the coils, use a vacuum cleaner with a wand attachment and a soft (non-metallic) brush to remove dirt and debris. Do not bend coil fins. Always wear gloves and protective eye wear when cleaning near sharp coil fins and dust particles.

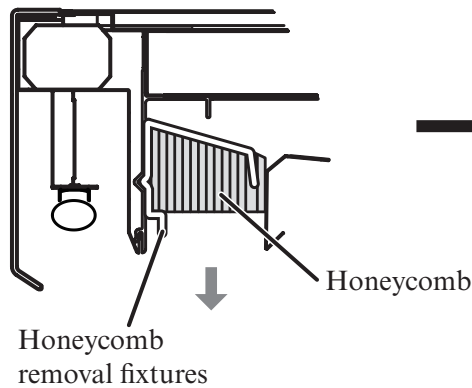

CLEANING HONEYCOMB

Clean periodically once a month.

If the honeycomb is not too dirty, tap honeycomb lightly to remove the dust.

If the honeycomb is very dirty, rinse off with water. Take care not to bend or mark the honeycomb. To remove the honeycomb, pull the honeycomb removal fixtures (two per honeycomb) down, and pull the honeycomb down and out.

To secure the honeycomb, push the entire honeycomb into the discharge air outlet, beginning from the end, position it horizontally, and push the anchor tabs on the honeycomb removal fittings until they are aligned with the honeycomb engagement groove. The honeycomb is at its optimum position when the groove and tab positions are aligned properly.)

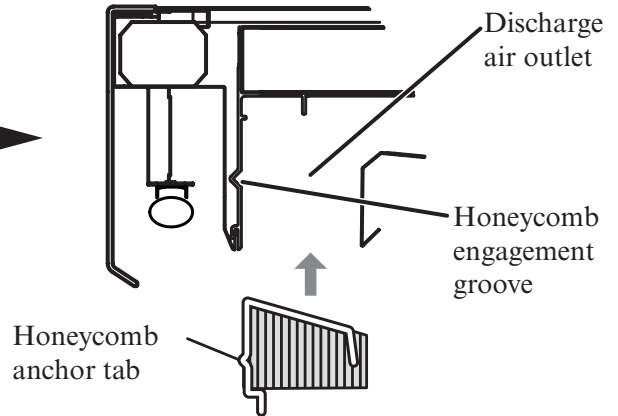

Condition of being removed

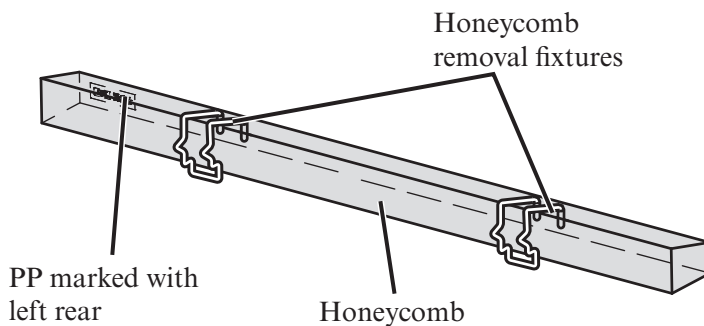

CLEANING POWER PLUG



Unplug

Remove the power plug from the power socket and clean off the dust and dirt on the terminals. Also clean off the dust and dirt on the power cord and the surrounding. After cleaning, wait 5 minutes before plugging the power plug back into the power socket. Check to ensure cord is not damaged or cracked. Contact Hussmann for a replacement cord, or a licensed service provider.



PRECAUTION
CLEANING PRECAUTIONS

When Cleaning:

- Do not use high pressure water hoses
- Do not introduce water faster than waste outlet can drain
- NEVER INTRODUCE WATER ON SELF CONTAINED UNIT WITH AN EVAPORATION PAN
- NEVER USE A CLEANING OR SANITIZING SOLUTION THAT HAS OIL BASE (these will dissolve the butyl sealants) or an AMMONIA BASE (this will corrode the copper components of the merchandiser)
- TO PRESERVE THE ATTRACTIVE FINISH:
- Use a water and a mild detergent for the exterior only
- Do NOT use a chlorinated cleaner on any surface
- Do NOT use abrasives or steel wool scouring pads (these will mar the finish)

CLEANING DRAIN EVAPORATION SYSTEM

If the condensor is clogged with dirt, an alarm code will be displayed on the controller. Cleaning the system requires disassembly. This merchandiser has an evaporation device that consists of 2 evaporation trays, and upper tray, and lower tray. Drain water goes to the upper tray first to evaporate, and any remaining water that does not evaporate will flow to the lower tray. The waste water then flows to the overflow drain pan.

Remove accumulated debris from the evaporation pan.

Debris or dirt accumulation inside the trays or on the condenser will reduce evaporation capacity. The evaporation pan waste water will overflow and spill onto the floor if the heater is not properly operating. Details of the evaporation system unit are shown on the next page.

CHANGING MOISTURE WICKING PLATES

Wicking plates must be replaced at least once per year. The expected life span of the moisture wicking plates will differ in accordance with the installation environment, but absorption capabilities will deteriorate with dust, oil and other forms of soiling. The wicking plates are shown in the illustration on the next page. Contact your Hussmann representative for replacement parts.

WARNING

Evaporation System may be Hot!
and pose risk of bodily injury — Always Wear gloves and protective eye wear when servicing. Turn off power and allow to cool before servicing.

CAUTION

Dust or dirt may accumulate within a short period depending on the conditions of the installation place or the environment for use. Check when cleaning. Wicking plate MUST be changed at least once a year.

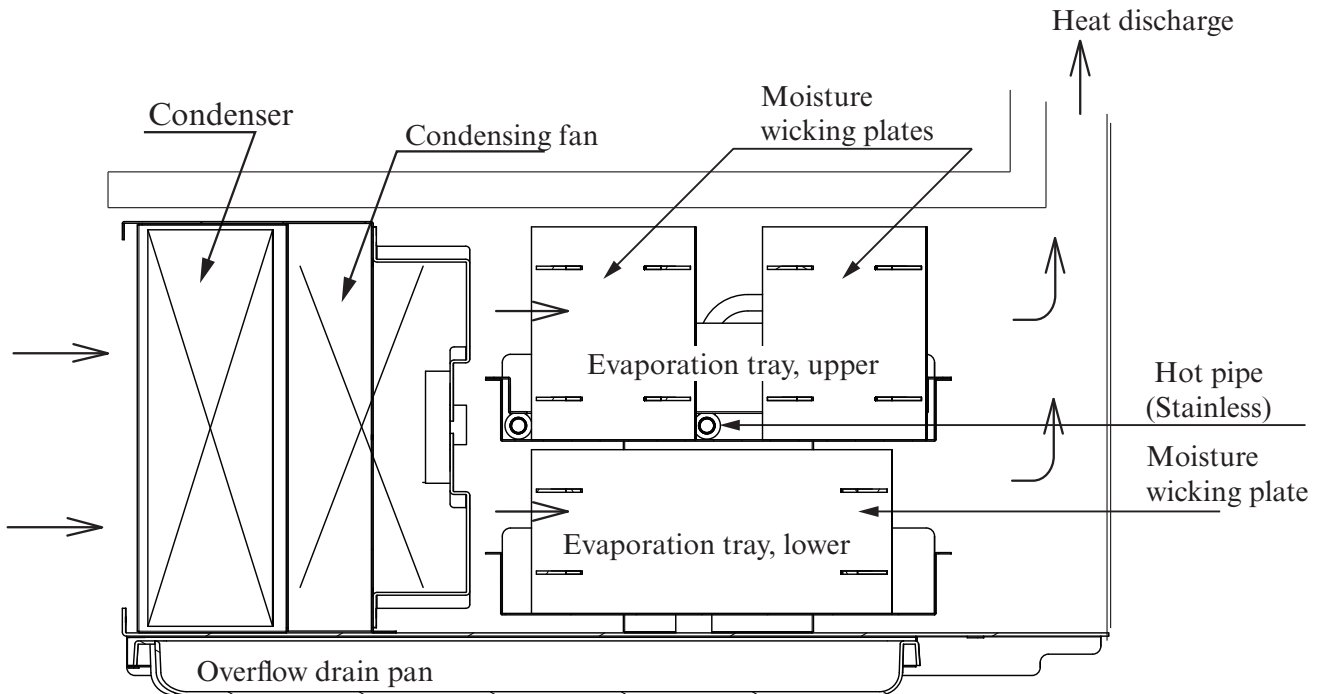
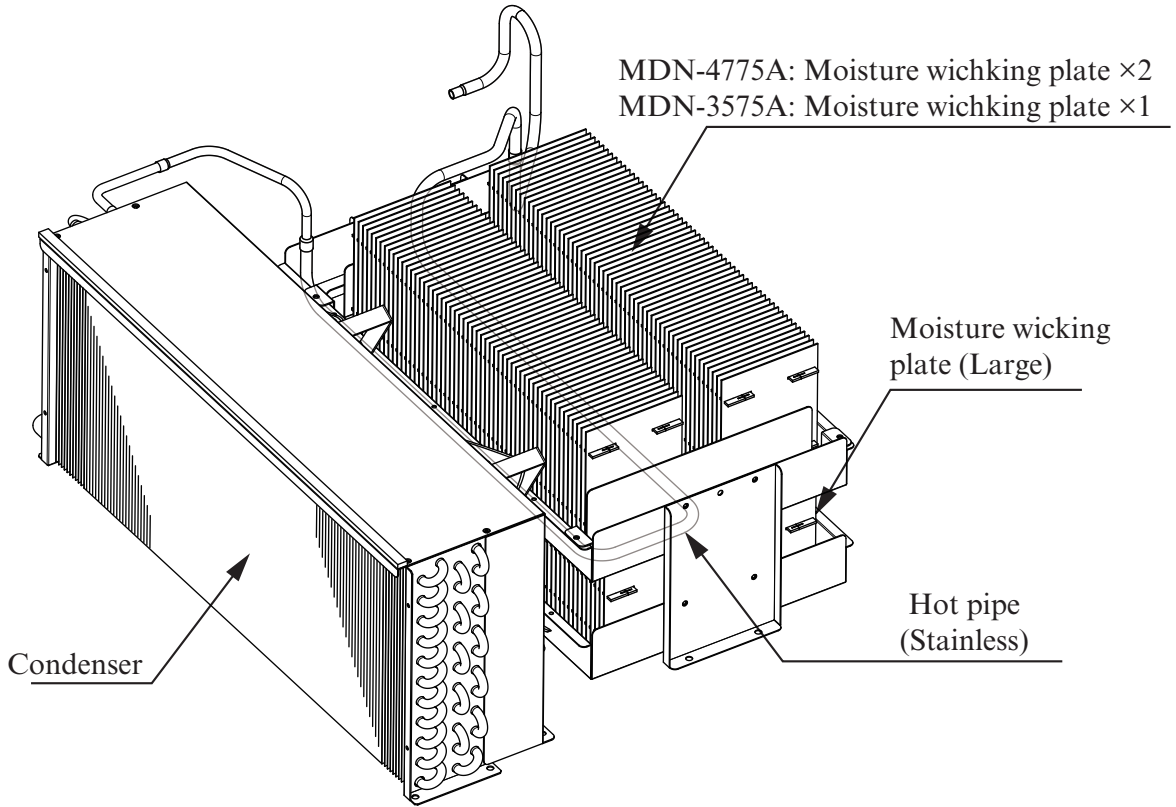

NIGHT CURTAIN (Optional)

Use the night curtain after business hours and during non-business days to save energy.

To use the night curtain:

1. Grasp the handle and pull downward. Hook the handle over the night curtain hook located on the backside of handrail.
2. Avoid the night curtain sheet touching the price tag moulding or items placed inside the case.

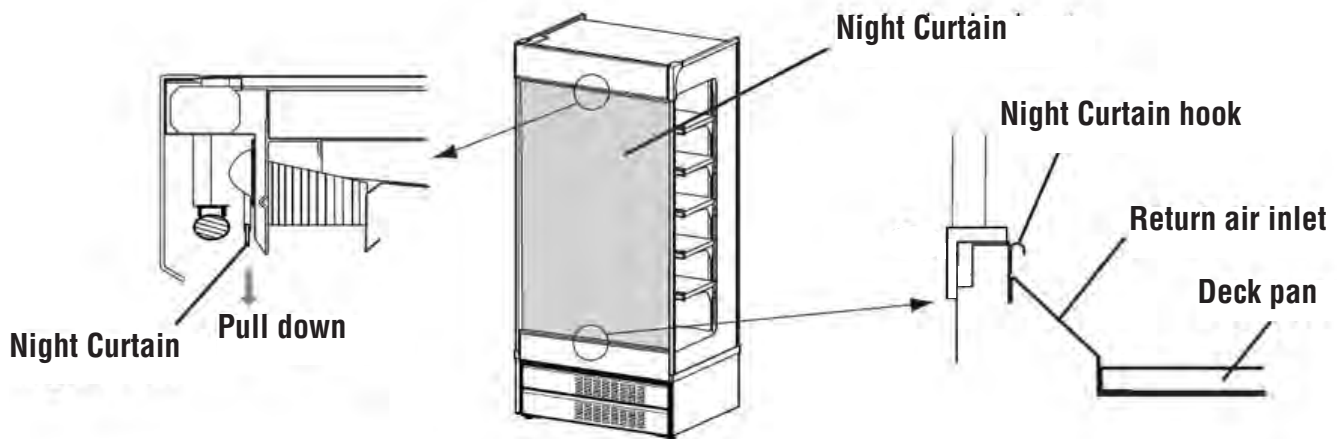

SERVICE

IN CASE OF THE FOLLOWING:

LED Lamp:

Contact your Hussmann representative to replace LED lamp fixtures. Fixtures must be replaced with like fixtures.

When not using the merchandiser for a long time:

Remove all items from the merchandiser, and the power plug from the power socket. Clean the inside of the cabinet, and wipe away any moisture. Make sure not to store the unused case in a place where children can play.

When “FL” flashes and displays on the digital display board:

“FL” flashes on the digital display board when the filter is clogged, ventilation of the condenser becomes bad by closing off with any items at air inlet opening or air outlet opening, or the outside air temperature becomes abnormally high. Clean the filter remove any obstacle to ventilation, and move to a place with ambient conditions that the cases requires to operate efficiently.

When other than “FL” displays on the digital board display:

Refer to indication symbols in the Electrical and Refrigeration Section of this manual.

Remove the power plug from the power socket while moving the merchandiser.

Check overflow drain pan under the case, and dispose of any water that has accumulated.

Be careful not damage the power cord with the leveling leg or caster while moving the product.

Be careful not damage any step or threshold with the leveling leg or caster.

When moving the merchandiser a long distance, use a trolley. Caution must be observed when moving the case to prevent it from toppling over if it is tilted more than necessary.



WARNING

Product will be degraded and may spoil if allowed to sit in a non-refrigerated area.



WARNING

— LOCK OUT / TAG OUT —

To avoid serious injury or death from electrical shock, always disconnect the electrical power at the main disconnect when servicing or replacing any electrical component. This includes, but is not limited to, such items as doors, lights, fans, heaters, and thermostats.

LED POWER SUPPLY LOCATION

the LED driver delivers DC power to the LED Lamp. The power supply is located at the bottom of the case behind the front panel. If it is determined that the power supply is not working and needs to be replaced, replace it with like components. Failure to place with a similar rated power supply will cause the LED lamp to be damaged or not work properly.

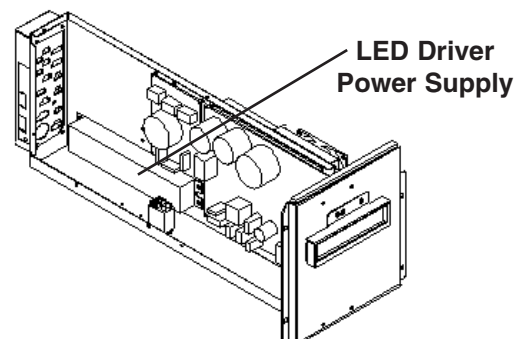

4-2 SERVICE

TROUBLESHOOTING

INVESTIGATE TROUBLE ACCORDING TO THE FOLLOWING TABLE.

Try performing the check points and actions to solve the problem. If the merchandiser does not work correctly, or you hear an abnormal noise, smell something abnormal or smoking, immediately stop using the merchandiser and remove the plug from the power socket. Remove all items from the merchandiser, and then inform the “Necessary information” to the supplier or dealer where you purchased the merchandiser or a licensed service provider.

Symptom	Check points	Actions
The case can not get cold at all	The power plug is disconnected.	Insert the power plug in securely.
	The power supply is cut off.	Confirm the recovery.
	The breaker for wiring is operated. The electric leakage breaker was operated.	Contact the supplier or dealer where you purchased the merchandiser or a licensed service provider.
The case is not cold enough	The wind is hitting the merchandiser.	Keep the wind speed less than 47.2 FPM (0.2 mps).
	The ambient temperature, humidity excessively high.	Refer to Page 1-1 for recommended operating ambient temperatures.
	The merchandiser is installed in direct sunlight, or near an oven or stove.	Move the location of the installation. Refer to “Location” on page 1-1 and 1-4.
	The setting of the temperature is high.	Refer to “Refrigeration Level Settings” on page 2-4.
	The items is inserted without per-cooling.	Refer to Page 1-4 for location requirements.
	The items close off the discharge air inlet or discharge air outlet.	
	The items are placed at the air inlet opening or air outlet opening of the condenser.	Do not place items hindering ventilation.
	The condenser is clogged.	Refer to “cleaning the filter” on Page 3-2.
The filter is dirty.	Clean periodically on for a month.	
The case is making an odd or loud noise.	The case is installed on an unstable floor.	Place the merchandiser securely on a strong and level floor.
	The case does not stand up correctly.	
	The rear of the case is touching a wall.	Move the merchandiser away from a wall.
	For a while after starting the case, you may hear some noise from the compressor. However, it will decrease soon.	
Dew formation outside of the case	<p>On a hot Summer days, or depending on the location of the installation, a dew may stick to the outer surface of the merchandiser (especially the glass surface).</p> <p>In case of high humidity, a dew is formed by touching cold objects to the moisture in the air, so it is not a malfunction. When the dew is attached, wipe off with a dry cloth.</p> <p>These case models are designed for operation in Type II or below environments.</p>	

SPECIFICATIONS

Product name Medium temperature self contained open vertical merchandiser

Model number		MDN-3575A			MDN-4775A			
Refrigerant / Charge		R404a / 31.75 oz (900g)			R404a / 40.55 oz (1150g)			
Capacity		13 ft ³			17.3 ft ³			
Dimensions		Width	Depth	Height	Width	Depth	Height	
	Exterior Dimensions (inches)		35	25 ⁵ / ₈	74 ³ / ₄	46 ⁷ / ₈	25 ⁵ / ₈	74 ³ / ₄
	Interior Dimensions (inches)		33 ³ / ₄	Shelf 11 ³ / ₄	53	45 ¹ / ₂	Shelf 11 ³ / ₄	53
Energy consumption 60 Hz at NSF Type I & Type II	Single-phase 110-120V	2,000 BTU / hr (Type I) 2,600 BTU / hr (Type II)			2,300 BTU / hr Type I 2,800 BTU / hr (Type II)			
Termination Temperature		46.4°F (8°C)			46.4°F (8°C)			
High Pressure (PSIG)		263			269			
Low Pressure (PSIG)		44			48			
Performance		Temperature inside the product (adjustable) Environment : Outside air temperature 80°F, humidity 55 %RH, ambient wind speed less than 47,2 FPM with no direct sunlight.						
LED light		17 Watts			21 Watts			
Product weight		386 lbs			463 lbs			
Accessories		Overflow drain pan, thermometer						
Others		Leveling leg: 2pc, Caster : 4pc						

DIRECT DRAIN

The evaporation system can be modified for a direct floor drain.

● (Below is an example of MDN-4775A.)

- ① Disconnect the power cord.
- ② Remove 2 screws of the front panel, then the panel itself.
- ③ Remove 8 screws in the area shown by  in the figure.

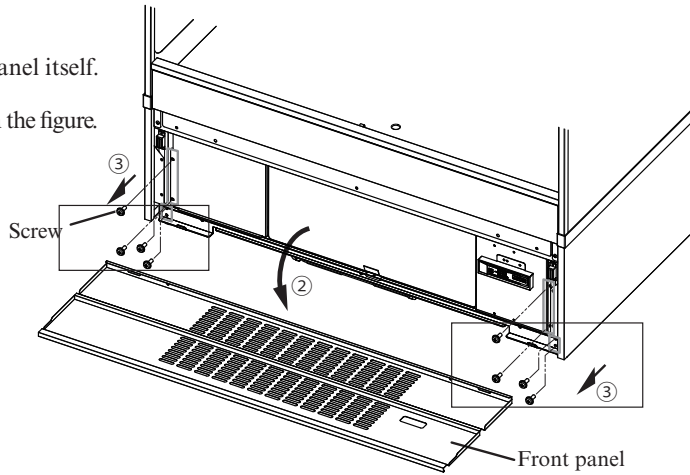

- ④ Pull out the unit.

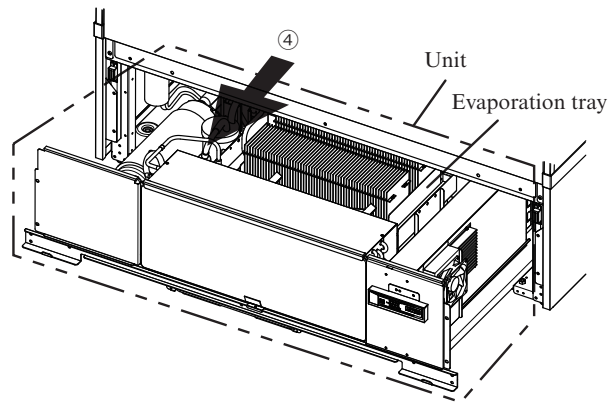

- ⑤ Release clips that hold wires connected to evaporation tray.
- ⑥ Remove 4 screws that fix the evaporation tray
(Marked with  in the figure at right.)

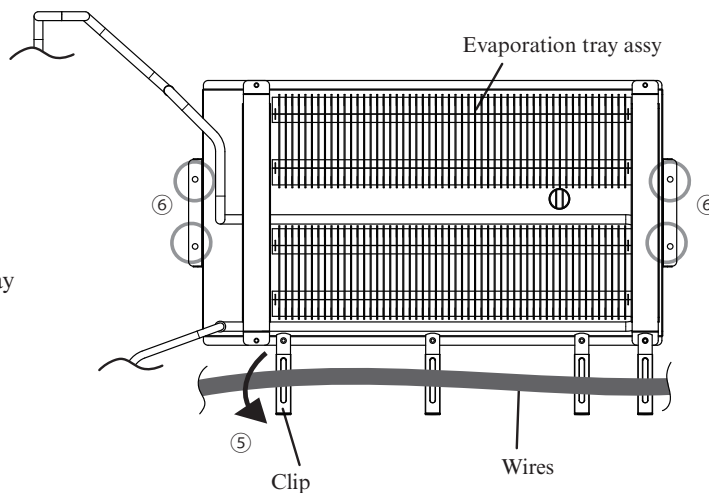

- ⑧ Remove 4 screws from the 2 brackets that attach to the hot pipe. Then remove evaporation tray assembly. (Do not remove the hot pipe.)

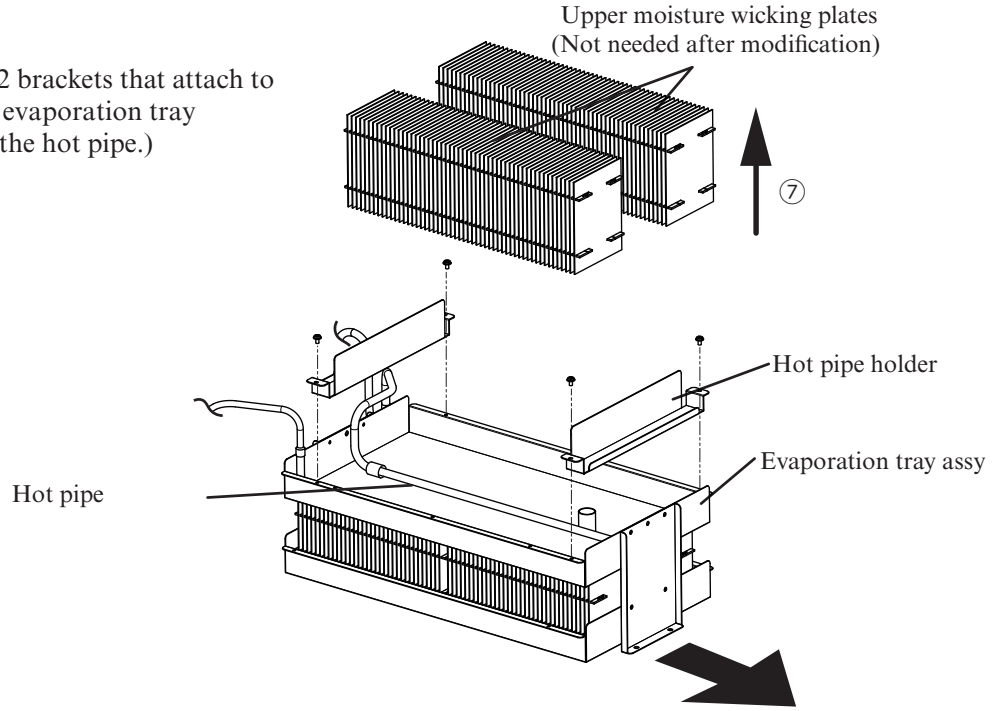

- ⑨ Remove 4 screws that attach to the lower evaporation tray and lower moisture wicking plate. Then remove the tray assembly and the moisture wicking plate.

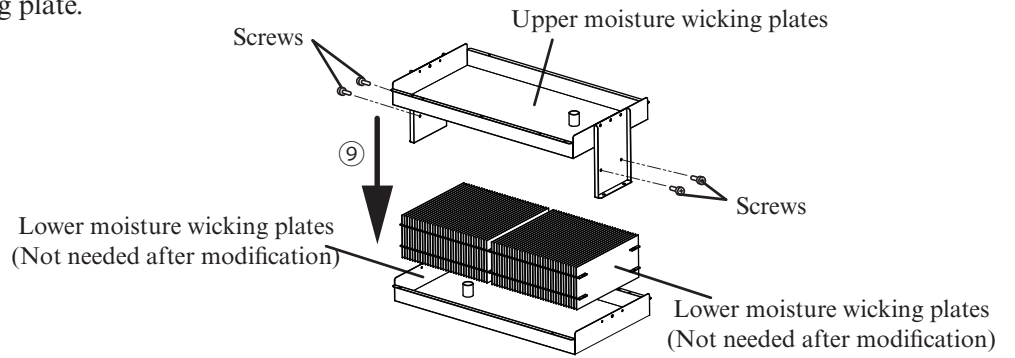

- ⑩ Attach a drain hose to the socket on the upper evaporation tray. Then apply a hose band to fix.

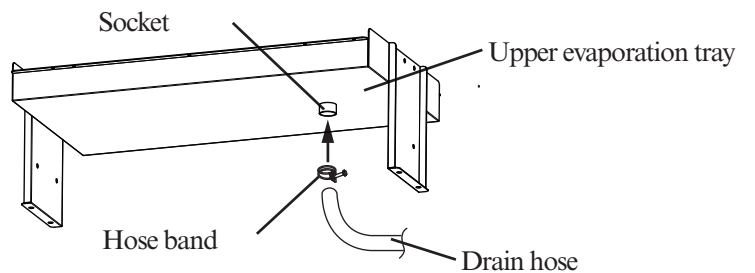

- ⑪ Apply caulking on drain hose connection to prevent water leaks.

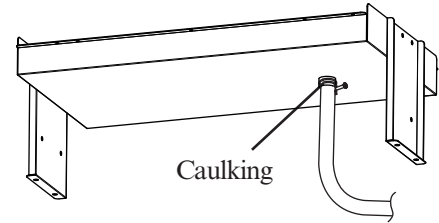

- ⑫ Mount the upper evaporation tray with the drain hose onto the unit base. Assemble parts removed by the steps taken in a reverse order.

- ⑬ Then remove back guard from the rear side of merchandiser. Pass the drain hose through the hole.

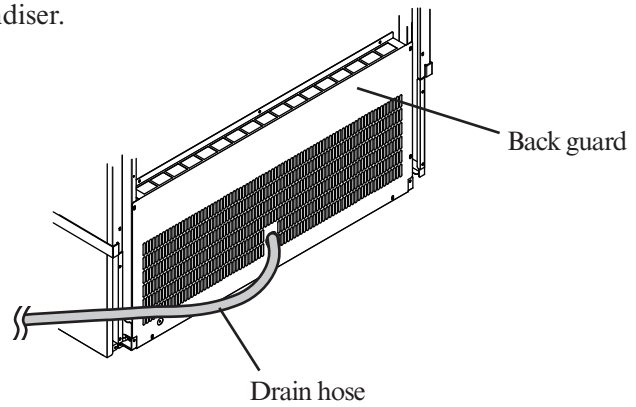

- ⑭ Make sure the back guard is mounted properly.

WIRING DIAGRAMS

MDN-3575A

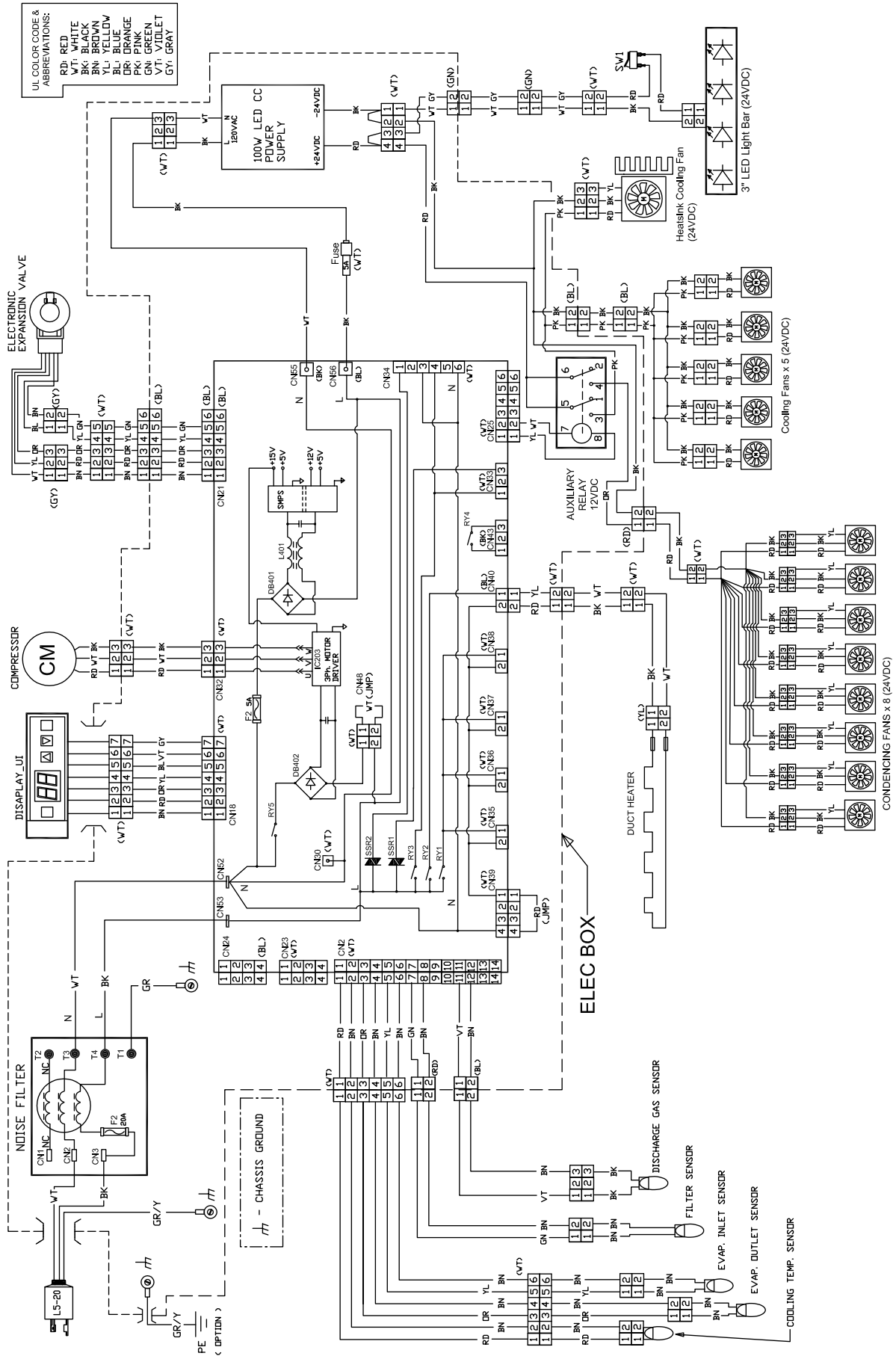



HUSSmann[®]

**To obtain warranty information
or other support, contact your
Hussmann representative.
Please include the model and
serial number of the product.**

Hussmann Corporation, Corporate Headquarters: Bridgeton, Missouri, U.S.A. 63044-2483 01 October 2012

Husmann Corporation

12999 St. Charles Rock Road
Bridgeton, MO 63044-2483
www.husmann.com

Printed in Mexico

Part Number
9FQ6P11000100A