

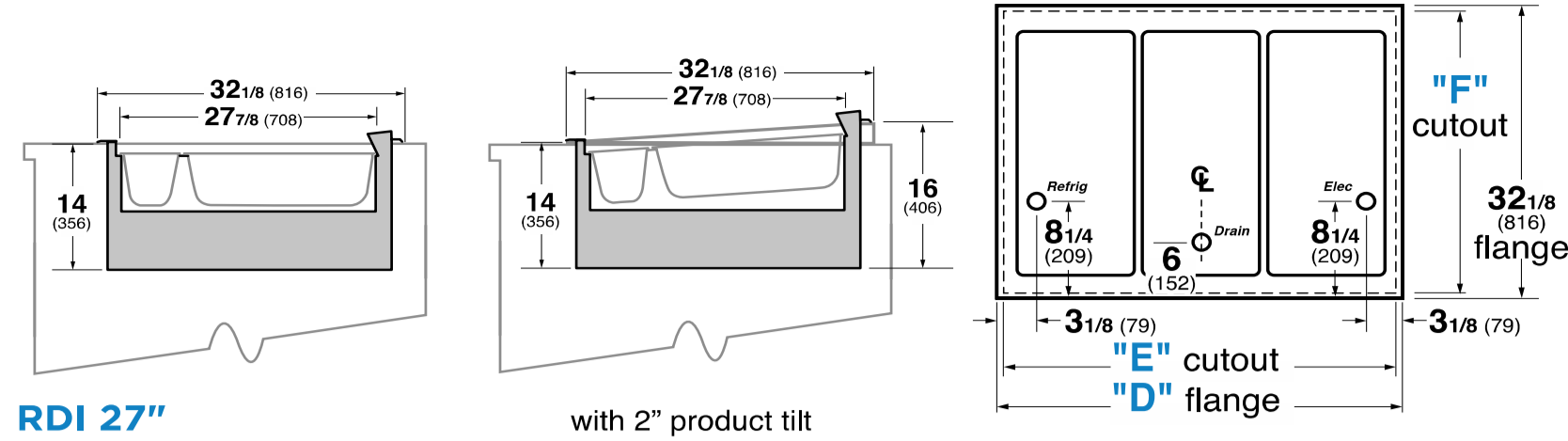

**REFRIGERATED DROP-IN, REMOTE**  
**HUSSMANN - RDI-27" (CHINO)**

REVISION DATE

03/03/25



**RDI 27"**

with 2" product tilt

		1	2	3	4	5	6	7
27"	"D" Flange	17 1/8"	28 3/4"	41 1/2"	54 3/8"	67 1/8"	80"	92 3/4"
	"E" Cutout	15 3/4"	27 3/8"	40 1/8"	53"	65 3/4"	78 5/8"	91 3/8"
	"F" Cutout	29 1/2"	30 3/4"					

**REFRIGERATION DATA:**

NUMBER OF WELLS	CASE USAGE	CAPACITY *** (BTU/HR/WELL)		TEMPERATURE (°F)			VELOCITY (FT/MIN)
		RATING CONDITION		EVAPORATOR		DISCHARGE AIR ** (°F)	
		NSF 7	AHRI 1200	NSF 7	AHRI 1200	NSF 7	
1, 2, 3, 4, 5, 6, 7, 8	COUNTER	840	NA	20	NA	29~31	325~375

WELLS	GLYCOL (18°F INLET, 4°F RISE)	
	GPM	PSI
1	0.3	0.0
2	0.6	0.3
3	0.9	0.5
4	1.2	0.7
5	1.5	0.9
6	1.8	1.3
7	2.1	0.8
8	2.4	1.1

\*\*FRONT DISCHARGE AIR MEASURED INSIDE AIR CURTAIN HONEYCOMB

\*\*\*REFRIGERATION NOTES:

- 1) USE DEW POINT FOR HIGH GLIDE REFRIGERANTS. CARE SHOULD BE TAKEN TO USE THE DEW POINT IN P/T TABLES FOR MEASURING AND ADJUSTING SUPERHEAT. ADJUST EVAPORATOR PRESSURE AS NEEDED TO MAINTAIN THE DISCHARGE AIR TEMPERATURE SHOWN.
- 2) REMOTE CASE RATING CONDITION IS NSF TYPE I, 75°F/55% RH

**REFRIGERATION DATA CONTINUED:**

ELEC. THERMOSTAT / AIR SENSOR SETTINGS					DEFROST TYPE	TIME (MIN)	DEFROST FREQUENCY (#/DAY)	TERM. TEMP (°F) COIL ONLY	DRIP TIME	DEFROST WATER (LBS/DAY/FT)
USAGE	CUT IN (°F)	CUT OUT (°F)	SET POINT (°F)	DIFFERENTIAL (°F)						
REMOTE	32	29	-	-	OFF TIME	20	6	54	TBD	1.7

END PANEL WIDTH KEY		
# OF END PNLS	END PNL WIDTH (IN.)	TOTAL ADDED LENGTH (IN.)
1	1.125	1.125
2	1.125	2.25

**ELECTRICAL DATA:**

**STANDARD FANS, HEATERS, LED LIGHTS (115 VOLT)**

NUMBER OF WELLS	EVAPORATOR FANS					CANOPY LIGHTS LED		OPTIONAL LED SHELF LIGHTS		MAX. LED LOAD (W/ ALL OPTIONS)		ANTI-SWEAT HEATERS		CONVENIENCE OUTLETS (OPTIONAL)		
	# OF EVAP FANS	BLADE DIA. (IN.)	BLADE PITCH (°)	AMPS	WATTS	AMPS	WATTS	AMPS	WATTS	AMPS	WATTS	AMPS	WATTS	# OUTLETS	VOLTS	AMPS
1	1	N/A	N/A	#N/A	#N/A	N/A	N/A	N/A	N/A	N/A	N/A	N/A	N/A	N/A	N/A	N/A
2	1	N/A	N/A	#N/A	#N/A	N/A	N/A	N/A	N/A	N/A	N/A	N/A	N/A	N/A	N/A	N/A
3	2	N/A	N/A	#N/A	#N/A	N/A	N/A	N/A	N/A	N/A	N/A	N/A	N/A	N/A	N/A	N/A
4	2	N/A	N/A	#N/A	#N/A	N/A	N/A	N/A	N/A	N/A	N/A	N/A	N/A	N/A	N/A	N/A
5	3	N/A	N/A	#N/A	#N/A	N/A	N/A	N/A	N/A	N/A	N/A	N/A	N/A	N/A	N/A	N/A
6	3	N/A	N/A	#N/A	#N/A	N/A	N/A	N/A	N/A	N/A	N/A	N/A	N/A	N/A	N/A	N/A
7	4	N/A	N/A	#N/A	#N/A	N/A	N/A	N/A	N/A	N/A	N/A	N/A	N/A	N/A	N/A	N/A
8	5	N/A	N/A	#N/A	#N/A	N/A	N/A	N/A	N/A	N/A	N/A	N/A	N/A	N/A	N/A	N/A

**OPTIONAL HIGH OUTPUT LED LIGHTS (115 VOLT)**

NUMBER OF WELLS	CANOPY LIGHTS H.O. LED		OPTIONAL SHELF		MAX. H.O. LED LOAD	
	AMPS	WATTS	AMPS	WATTS	AMPS	WATTS
1	N/A	N/A	N/A	N/A	N/A	N/A
2	N/A	N/A	N/A	N/A	N/A	N/A
3	N/A	N/A	N/A	N/A	N/A	N/A
4	N/A	N/A	N/A	N/A	N/A	N/A
5	N/A	N/A	N/A	N/A	N/A	N/A
6	N/A	N/A	N/A	N/A	N/A	N/A
7	N/A	N/A	N/A	N/A	N/A	N/A
8	N/A	N/A	N/A	N/A	N/A	N/A