



ID5SL12 shown

## Certifications



**Intertek**

### NSF/Sanitation Compliance

This merchandiser model is manufactured to meet NSF/ANSI Standard 7 requirements for construction, materials, and cleanability.

**⚠ WARNING**

Component parts shall be replaced with like components, and servicing shall be done by factory authorized service personnel only, so as to minimize the risk of possible ignition due to incorrect parts or improper service.

## Technical Datasheet

### ID5SL

Open Multideck Medium Temperature Display Case

### Applications

Beverage, Dairy, Deli, Produce, and Meat

P/N 0535977 Rev R  
February 2026

### Models Covered

ID5SL4, ID5SL6,  
ID5SL8, ID5SL12

### Refrigerant(s)

A2L (R-454A or R-454C)  
R-744 (CO<sub>2</sub>)  
Glycol  
HFC/HCFC/HFO

### Table of Contents

Model Name	2
Performance Data	3
Refrigerant Data	4
Additional Data	5
Cross-section View	6
Plan View	7
Estimated Shipping Weight	8
Electrical Specifications	9
Wiring Diagrams	10

We reserve the right to change or revise specifications and product design in connection with any feature of our products. Such changes do not entitle the buyer to corresponding changes, improvements, additions, or replacements for equipment previously sold or shipped.

**WARNING:**

**Read the entire installation, operation, and service manual before installing, servicing, or using this equipment in any way. Refer to the manual for detailed information about minimum room floor area and installation, maintenance, and service processes.**

**A2L Equipped Models**

If the information in the instructions are not followed exactly, a fire or explosion may result, causing property damage, personal injury, or death. Installation and service must be performed by a qualified installer or service agency.



Mildly flammable A2L refrigerant used. Units that are configured to use A2L refrigerants require special attention. No open flames, cigarettes, or other possible sources of ignition should be used inside or in the vicinity of units containing flammable refrigerants.

If a refrigerant leak is present or even suspected, do not allow untrained personnel to attempt to find the cause. No open flames, cigarettes, or other possible sources of ignition should be used inside or in the vicinity of the unit(s). Intrinsically safe components are the only types that can be worked on while live in the presence of a flammable atmosphere.

Information on pre-installed A2L refrigerant sensors and detectors, safety shut-off and check valves, relay information, and additional parts replacement information can be found in the associated installation, operation, and service manual. All manual information must be reviewed in full prior to performing any work.

**R-744 (CO<sub>2</sub>) Equipped Models**

This equipment uses carbon dioxide (R-744 [CO<sub>2</sub>]) refrigerant for heat transfer. The system is sealed and pressure-tested with ASME-certified vessels, but leaks can occur in the event of a system failure. A CO<sub>2</sub> leak in an unventilated space can pose serious hazards. Therefore, units must be installed in areas with adequate ventilation and in accordance with local safety codes.

A leak of R-744 could result in a concentration exceeding the practical limit in an enclosed, occupied space such as a cold room. Precautions must be taken to prevent asphyxiation. These include the use of permanent leak detection, which activates an alarm in the event of a leak.



Observe all warnings and labels on the unit being installed or serviced such as the one below indicating high pressure.

All refrigeration servicing must be completed by a certified refrigeration installation professional, and all tubing and components **MUST** be qualified for CO<sub>2</sub> applications, with a minimum design pressure of 1,305 psig (90 bar).

**Failure to abide by all warnings contained within the associated manual could result in an explosion, death, injury, and property damage.**

**Model Nomenclature**

“ID5SL” is followed by a number representing the length of the case in feet (i.e., a 12-foot model would be “ID5SL12”).

**Ordering Information**

All options must be selected at time of ordering. Some lengths and/or applications require optional fan motor kits applied by the Hussmann Product Configurator (HPC).

**Performance Data<sup>A</sup>**

Data Type		Beverage/Dairy/ Deli/Produce	Convertible/Meat	NSF II Ambient <sup>C</sup>	Pegboard <sup>D</sup>
		NSF I Ambient	NSF I Ambient		NSF I Ambient
Unlit Shelves	Discharge Air Temperature	32° F (0° C)	31° F (-0.6° C)	30° F (-1.1° C)	30° F (-1.1° C)
	Evaporator Temperature <sup>B</sup>	28° F (-2.2° C)	27° F (-2.8° C)	26° F (-3.3° C)	26° F (-3.3° C)
	Parallel Capacity <sup>F</sup> per Foot (meter)	1,020 BTU/h (981 W)	1,120 BTU/h (1,077 W)	1,295 BTU/h (1,245 W)	1245 BTU/h (1,197 W)
	Conventional Capacity <sup>F</sup> per Foot (meter)	1,115 BTU/h (1,072 W)	1,220 BTU/h (1,173 W)	1,410 BTU/h (1,356 W)	1,360 BTU/h (1,308 W)
Lit Shelves	Discharge Air Temperature	31° F (-0.6° C)	30° F (-1.1° C)	29° F (-1.7° C)	N/A
	Evaporator Temperature <sup>B</sup>	27° F (-2.8° C)	26° F (-3.3° C)	25° F (-3.9° C)	N/A
	Parallel Capacity per Foot (meter) <sup>F,G</sup>	1,040 BTU/h (1,000 W)	1,130 BTU/h (1,087 W)	1,320 BTU/h (1,269 W)	N/A
	Conventional Capacity per Foot (meter) <sup>F,G</sup>	1,135 BTU/h (1,091 W)	1,230 BTU/h (1,183 W)	1,440 BTU/h (1,385 W)	N/A
Fan Speed <sup>I</sup>	ID5SL4, 6, 8, 12 (8.25 in)	1,300 RPM	1,500 RPM	1,500 RPM	1,300 RPM
AHRI Rating <sup>E</sup> (NSF I ambient)	Unlit Shelves	Discharge Air Temperature		35° F (1.7° C)	
		Evaporator Temperature <sup>B</sup>		31° F (-0.6° C)	
		Parallel Capacity per Foot (meter)		955 BTU/h (918 W)	
		Conventional Capacity per Foot (meter)		1,040 BTU/h (1,000 W)	
	Lit Shelves	Discharge Air Temperature		34° F (1.11° C)	
		Evaporator Temperature <sup>B</sup>		30° F (-1.1° C)	
		Parallel Capacity per Foot (meter)		965 BTU/h (928 W)	
		Conventional Capacity per Foot (meter)		1,055 BTU/h (1,014 W)	
Low Pressure Backup Control (CI/CO) <sup>H</sup>		20° F (-6.7° C) / 10° F (-12.2° C)			

<sup>A</sup> All data based on store temperature and humidity that does not exceed NSF Type I ambient conditions of 75° F (23.9° C) and 55% relative humidity, except where noted. Reduce refrigeration load by 15% if fitted with CaseShieldPTM.

<sup>B</sup> Average evaporator temperature shown. Use dew point for high-glide refrigerants for unit sizing. Care should be taken to use the dew point in PT (pressure-temperature) tables for measuring and adjusting superheat. Adjust evaporator pressure as needed to maintain discharge air temperature shown.

For DX R-744 (CO2) applications, the average evaporator temperature may be lowered by 2° F (1.1° C), but not more than 5° F (2.8° C).

An EPR valve should be used if the system suction temperature is more than 5° F (2.8° C) below the published case evaporator temperature. A 31° F (-0.6° C) flash tank temperature with a 24° F (-4.4° C) evaporator temperature is used when sizing default EEV selections to provide a minimum pressure drop across the valve of approximately 50 PSIG (3.4 bar). For operating conditions that provide a pressure drop across the valve above 65 PSIG (4.5 bar) or below 35 PSIG (2.4 bar), the EEV size should be determined using the valve vendor sizing program and selected from the pull down list in the Hussmann Product Configurator (HPC).

<sup>C</sup> NSF Type II ambient conditions of 80° F (26.7° C) and 55% relative humidity.

<sup>D</sup> Hussmann peg shelves for dairy and deli applications only.

<sup>E</sup> AHRI 1200 rating point for energy consumption comparison only.

<sup>F</sup> Subtract 60 Btu/h/ft (57.7 W/m) for front glass (on applicable models).

<sup>G</sup> Add 10 BTU/h/ft (9.6 W/m) per shelf row for LED shelf light fixtures.

<sup>H</sup> Use a temperature pressure chart to determine PSIG (bar) conversions.

<sup>I</sup> Some lengths and/or applications require optional fan motor kits applied by the Hussmann Product Configurator (HPC).

**Performance Data (cont.)****Defrost Data**

Frequency	4 hours between defrost cycles
Time	20 minutes
Temp. Termination <sup>J</sup>	N/A
Defrost Type	offtime
Defrost Water <sup>K</sup>	8.1 lb/ft/day (12 kg/m)

**Product Data**

Gross Refrigerated Volume <sup>L</sup>	11.6 ft <sup>3</sup> /ft of length (1.08 m <sup>3</sup> /m of length)
AHRI Total Display Area <sup>M</sup>	4.56 ft <sup>2</sup> /ft of length (1.39 m <sup>2</sup> /m of length)
Shelf Surface Area <sup>N</sup>	9.85 ft <sup>2</sup> /ft of length (3 m <sup>2</sup> /m of length)

**Refrigerant Data****Approximate HFC/HCFC/HFO Refrigerant Charge<sup>O</sup>**

Case	Estimated Charge
ID5SL4	10 oz (284 g)
ID5SL6	18 oz (510 g)
ID5SL8	24 oz (680 g)
ID5SL12	46 oz (1,304 g)

**A2L Refrigerant Charge**

Model	Minimum Room Floor Area ft <sup>2</sup> (m <sup>2</sup> )	Estimated Refrigerant Charge— lb (g)	
		Operating Charge	
		R-454A	R-454C
ID5SL4	106 (9.8)	1.4 (657)	1.4 (657)
ID5SL6	106 (9.8)	1.9 (877)	2 (887)
ID5SL8	196 (18.2)	2.5 (1,125)	2.5 (1,137)
ID5SL12	196 (18.2)	3.6 (1,643)	3.7 (1,660)

**R-744 (CO<sub>2</sub>) Pressure Rating**

Case Configuration	Pressure Rating
standard pressure CO <sub>2</sub>	652 psi (45 bar)
high pressure CO <sub>2</sub>	1,305 psi (90 bar)

<sup>J</sup> Use a Temperature Pressure Chart to determine PSIG conversions.<sup>K</sup> ± 15% based on case configuration and product loading.<sup>L</sup> AHRI Gross Refrigerated Volume: Refrigerated Volume/Unit of Length, ft<sup>3</sup>/ft [m<sup>3</sup>/m]<sup>M</sup> Computed using AHRI 1200 standard methodology: Total Display Area, ft<sup>2</sup> [m<sup>2</sup>]/Unit of Length, ft [m]<sup>N</sup> Shelf surface area is composed of bottom deck plus standard shelf complement for this model: (5) rows of 22-in. shelves<sup>O</sup> This is an average for all refrigerant types. Actual refrigerant charge may vary by approximately half a pound.

**Glycol Heat Transfer Fluid Data (Dairy, Deli)**

Model	Conventional Load BTU/h/ft (W/m)	Discharge Air Temperature ° F (° C)	Coil Inlet Temperature ° F (° C)	Coil Temp. Rise ° F (° C)	Average Coil Temperature ° F (° C)	Flow Rate GPM (LPM)	Pressure Drop PSI (bar)
ID5SL4	1,175 (1,130)	31 (-0.6)	25 (-3.9)	4 (2.2)	27 (-2.8)	2.5 (9.5)	7.6 (0.5)
			20 (-6.7)	14 (7.8)	27 (-2.8)	0.7 (2.6)	1.6 (0.1)
ID5SL6	1,175 (1,130)	31 (-0.6)	25 (-3.9)	4 (2.2)	27 (-2.8)	3.8 (14.4)	12.6 (0.9)
			20 (-6.7)	14 (7.8)	27 (-2.8)	1.1 (4.2)	1.1 (0.1)
ID5SL8	1,175 (1,130)	31 (-0.6)	25 (-3.9)	4 (2.2)	27 (-2.8)	5.1 (19.3)	8.6 (0.6)
			20 (-6.7)	14 (7.8)	27 (-2.8)	1.4 (5.3)	2.0 (0.1)
ID5SL12	1,175 (1,130)	31 (-0.6)	25 (-3.9)	4 (2.2)	27 (-2.8)	7.6 (28.8)	14.7 (1.0)
			20 (-6.7)	14 (7.8)	27 (-2.8)	2.2 (8.3)	2.2 (0.2)

**Glycol Heat Transfer Fluid Data (Meat)**

Model	Conventional Load BTU/h/ft (W/m)	Discharge Air Temperature ° F (° C)	Coil Inlet Temperature ° F (° C)	Coil Temp. Rise ° F (° C)	Average Coil Temperature ° F (° C)	Flow Rate GPM (LPM)	Pressure Drop PSI (bar)
ID5SL4	1,270 (1,223)	30 (-1.1)	25 (-3.9)	4 (2.2)	27 (-2.8)	2.7 (10.2)	8.4 (0.6)
			20 (-6.7)	12 (6.7)	26 (-3.3)	0.9 (3.4)	2.9 (0.2)
ID5SL6	1,270 (1,223)	30 (-1.1)	25 (-3.9)	4 (2.2)	27 (-2.8)	4.1 (15.5)	5.8 (0.4)
			20 (-6.7)	12 (6.7)	26 (-3.3)	1.4 (5.3)	2.2 (0.2)
ID5SL8	1,270 (1,223)	30 (-1.1)	25 (-3.9)	4 (2.2)	27 (-2.8)	5.5 (20.8)	9.8 (0.7)
			20 (-6.7)	12 (6.7)	26 (-3.3)	1.8 (6.8)	1.5 (0.1)
ID5SL12	1,270 (1,223)	30 (-1.1)	25 (-3.9)	4 (2.2)	27 (-2.8)	8.2 (31.1)	10.1 (0.7)
			20 (-6.7)	12 (6.7)	26 (-3.3)	2.7 (10.2)	2.9 (0.2)

**Cross-Section View**

Standard shelf compliment shown as tested—four rows of 22 in. (559 mm) shelves spaced equally between bottom display pan and interior top panel. 1 1/2 in. (38 mm) spacing is required behind the merchandiser between a surface such as a wall or other cases.

**ID5SL**

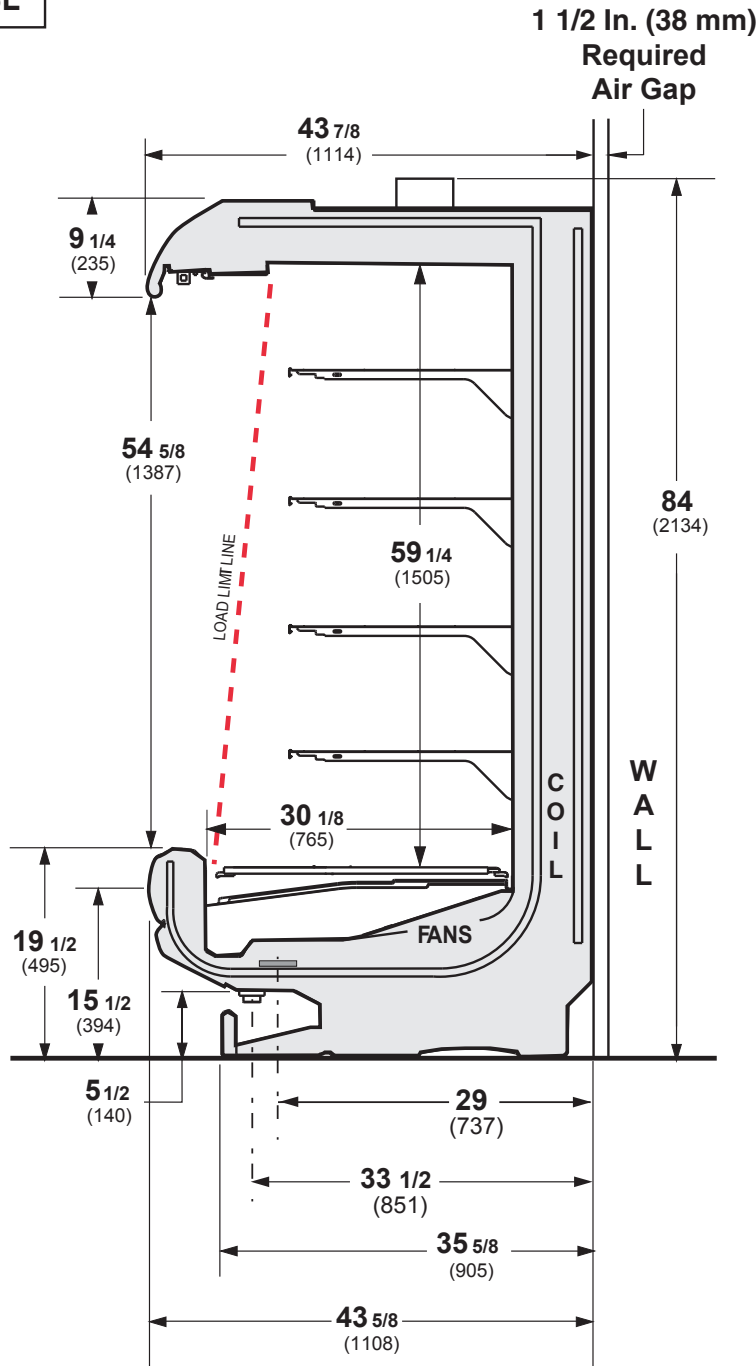

dimensions shown as in. (mm)

Shown with ellipse option canopy and bumper.

A minimum 1 1/2 in. (38 mm) clearance required to remove raceway cover, 6 1/2 in. (165 mm) for full access. A 3-in. space is required between back-to-back cases. See the installation manual for additional information.

Other optional kits (top piping and vent fans) add to the overall case height.

**OPTIONAL RAIL LIGHT**

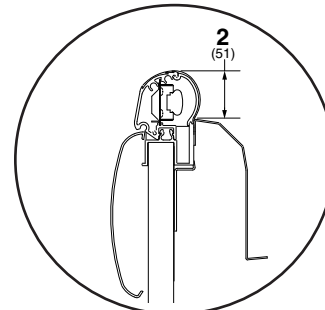

**OPTIONAL GLASS FRONT**

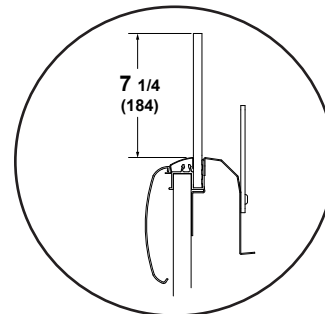

Plan View

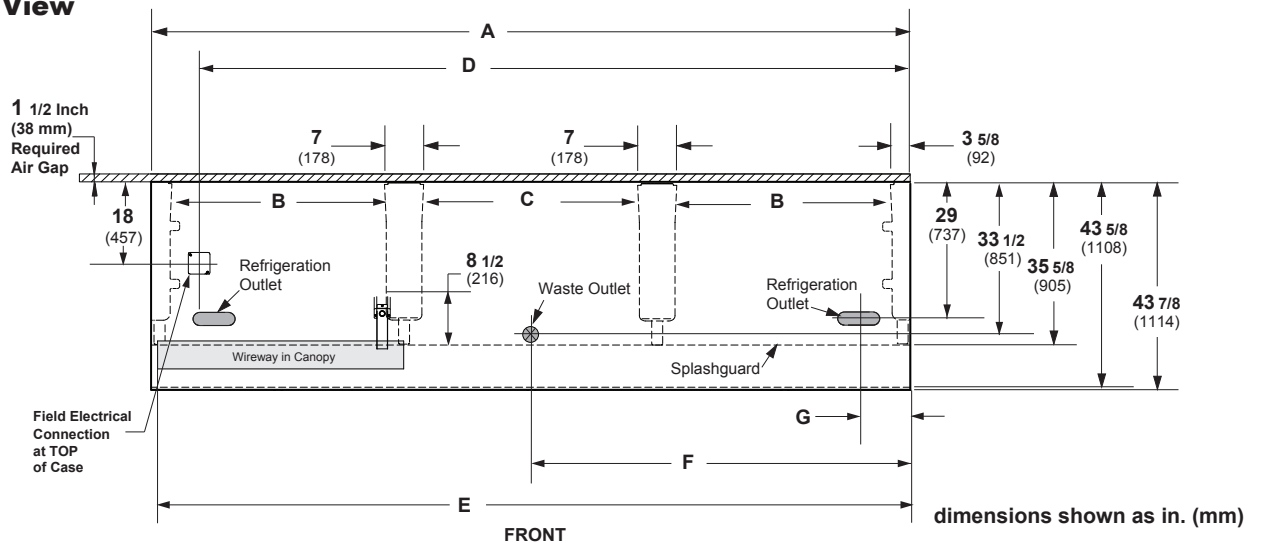

Dimension		ID5SL4	ID5SL6	ID5SL8	ID5SL12
General	A — case length (without ends or partitions) <sup>P</sup>	48 1/8 (1,222)	72 1/4 (1,835)	96 1/4 (2,445)	144 3/8 (3,668)
	maximum o/s dimension of case back to front (includes bumper)	43 5/8 (1,108)			
	back of case to front of splashguard	35 5/8 (905)			
	B — distance between edges of external legs and center legs	N/A	29 (737)	41 (1,041)	41 (1,041)
	C — distance between edges of center legs	41 1/8 (1,045)	N/A	N/A	41 1/8 (1,045)
	distance between front legs and splashguard	8 (203)			
Electrical Service <sup>Q</sup>	D — RH end of case to center of field electrical wiring connection (top of case)	39 3/8 (1,000)	63 1/2 (1,613)	87 1/2 (2,223)	135 1/2 (3,442)
	back of case to center of field electrical wiring connection	18 (457)			
	length of electrical wireway	44 5/8 (1,133)	33 1/2 (851)	45 7/8 (1,165)	45 7/8 (1,165)
	E — RH end of case to LH end of electrical wireway (top of case)	46 1/2 (1,181)	70 1/2 (1,791)	94 1/2 (2,400)	142 5/8 (3,630)
Waste Outlets <sup>R</sup>	F — RH end of case to the center of outlet	24 1/8 (613)	24 1/8 (613)	24 1/8 (613)	72 1/4 (1,835)
	back outside of case to center of outlet(s)	33 1/2 (851)			
	schedule 40 PVC drip pipe	1 1/4 (32)			
Refrigeration Outlet	G — back of case to center of outlet	29 (737)			
	end of case to center of outlet	8 1/2 (216)			

<sup>P</sup> Each solid end adds approximately 1 1/2 in. (38 mm) to length of line up. Each partition adds approximately 1 1/2 in. (38 mm). Case to case joints add approximately 1/8 in. (3 mm) for gasket material. Optional view end with end bumper adds 3 3/4 in. (95 mm)

<sup>Q</sup> Electrical field wiring connection point is at terminal block. Not intended for case to case connections.

<sup>R</sup> Field-installed waste outlets, tees, and connectors are shipped with case.

**Additional Dimensional Data**

**Ends and Partitions**

Each solid end adds approximately 1 1/2 in. (38 mm) to length of line up. Each partition adds approximately 1 1/2 in. (38 mm). Case to case joints add approximately 1/8 in. (3 mm) for gasket material. Optional view end with end bumper adds 3 3/4 in. (95 mm)

**Drip Pipe, Liquid Line, and Suction Line**

The below values represent only a sample of the most common connection sizes. Consult a Hussmann representative for additional data related to specific case size and refrigerant variations.

<b>Merchandiser Drip Line</b>	1 1/4 in.
<b>Merchandiser Liquid Line</b>	3/8 in.
<b>Merchandiser Suction Line</b>	5/8 in.

**Estimated Shipping Weight<sup>Q</sup>**

<b>ID5SL4</b>	<b>ID5SL6</b>	<b>ID5SL8</b>	<b>ID5SL12</b>	<b>Solid End (each)</b>
700 lb (408 kg)	850 lb (386 kg)	1,000 lb (454 kg)	1,100 lb (499 kg)	80 lb (36 kg)

**Shelf Options**

Approved shelf sizes for standard shelves with two or three position brackets in horizontal position are 18 in. (457 mm), 20 in. (508 mm), 22 in. (559 mm), and 24 in. (610 mm). Standard shelf count is four. Depending on optional configuration, shelf count can range from three to eight shelves (three to six for lighted shelves). Contact a Hussmann Engineering representative for information on non-standard shelf or display recommendations. Shelves are designed to support the maximum weight load limits as indicated in the table below.

<b>Shelf Depth</b>	<b>Max. Load Limit (at 0° tilt)</b>
18 in. (457 mm)	200 lb (91 kg)
20 in. (508 mm)	250 lb (113 kg)
22 in. (559 mm)	250 lb (113 kg)
24 in. (610 mm)	250 lb (113 kg)

<sup>Q</sup> Actual weight will vary according to optional kits included.

**Electrical Specifications**

Hussmann refrigerated merchandisers configured for sale and use in the United States meet or surpass the requirements of DOE energy efficiency standards. ID5SL4 (4-foot) display cases have one 8.25 in. fan, ID5SL6 (6-foot) / ID5SL8 (8-foot) cases have two 8.25 in. fans, and ID5SL12 (12-foot) have three 8.25 in. fans.

Each case requires an appropriate supply power connection. Standard electrical connections are on top of the case in the electrical box. Refer to the labeling on the unit for the required voltage for that specific configuration.

Fan electrical load for a case comes from multiplying the number of fans by the current draw per fan and is listed as a total value for the case. Lighting may be on a separate circuit, but lighted shelves work similarly, where the number of lighted shelves is multiplied by the current draw of each shelf. Total values per case by configuration are shown for simplicity based on the number of rows of lit shelves.

Refer to store legend to determine number of circuits. Lighting should be specified in store legend. When applicable, fans, anti-sweat heaters, controllers, etc., must all be included in the MCA value. Include lights in the MCA if lights are on same circuit.

**Warning: Terminal block NOT for case-to-case wire connection.**

Case Specifications	Voltage	ID5SL4	ID5SL6	ID5SL8	ID5SL12
Minimum Circuit Ampacity (MCA)	120 VAC	0.45	0.7	0.7	0.95
	230 VAC	0.33	0.46	0.46	0.59
Maximum Over Current Protection (MOPD)	120 VAC	20	20	20	20
	230 VAC	15	15	15	15

Component Specifications		ID5SL4		ID5SL6		ID5SL8		ID5SL12	
Component Type	Input Voltage	Amps	Watts	Amps	Watts	Amps	Watts	Amps	Watts
Evaporator Fan	120 VAC	0.25	16	0.50	32	0.50	32	0.75	48
	230 VAC	0.13	16	0.26	32	0.26	32	0.39	48
Standard Lighting LED Canopy Lights	24 VDC	0.16	19	0.22	27	0.31	38	0.47	57
Optional 2 Rows of Canopy Lights	24 VDC	0.32	38	0.44	54	0.62	76	0.94	114
Optional LED Shelf Lighting per number of shelf rows (1-6)	24 VDC	0.06	7	0.07	9	0.11	13	0.17	20
	24 VDC	0.11	13	0.15	18	0.22	27	0.33	40
	24 VDC	0.17	20	0.22	27	0.33	40	0.50	60
	24 VDC	0.22	27	0.30	36	0.44	53	0.67	80
	24 VDC	0.28	33	0.37	44	0.56	67	0.83	100
	24 VDC	0.33	40	0.44	53	0.67	80	1.00	120
LED Rail Light	24 VDC	0.06	7	0.07	9	0.11	13	0.17	20

**Wiring Diagram (LED canopy and optional rail light circuits)**

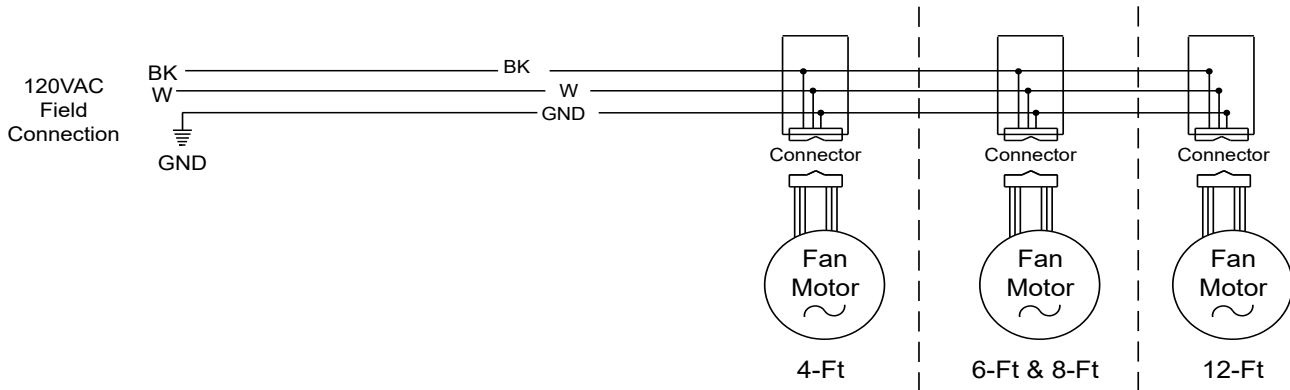

**LED Canopy Lighting - 2 Rows**

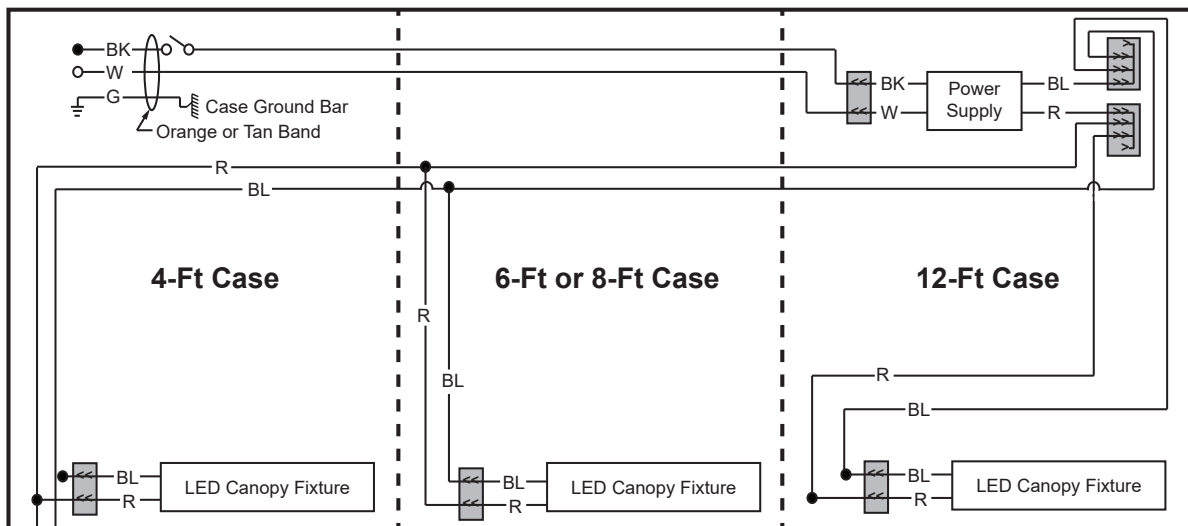

**Optional LED Lighting - LED Rail - 1 Row**

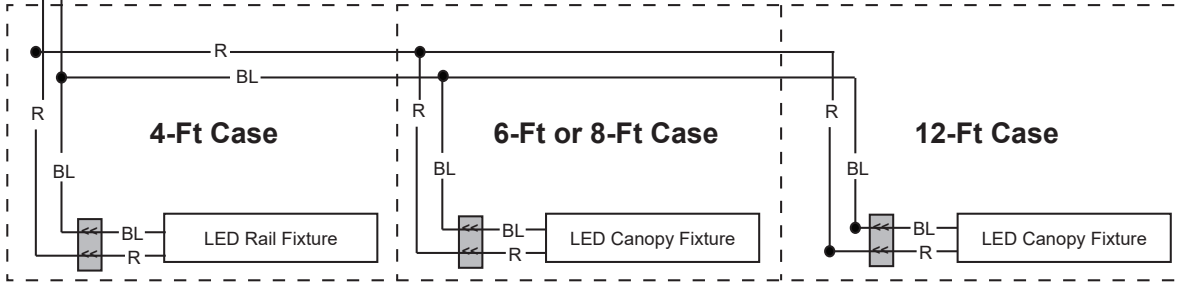

**WARNING**

All components must have mechanical ground, and the merchandiser must be grounded.

R = Red Y = Yellow G = Green BL = Blue BK = Black W = White  
 ● = 120V POWER ○ = 120V NEUTRAL ⚡ = FIELD GROUND  $\text{mm}$  = CASE GROUND

**Wiring Diagram (LED shelf light circuits, 4 or 5 rows of shelves)**

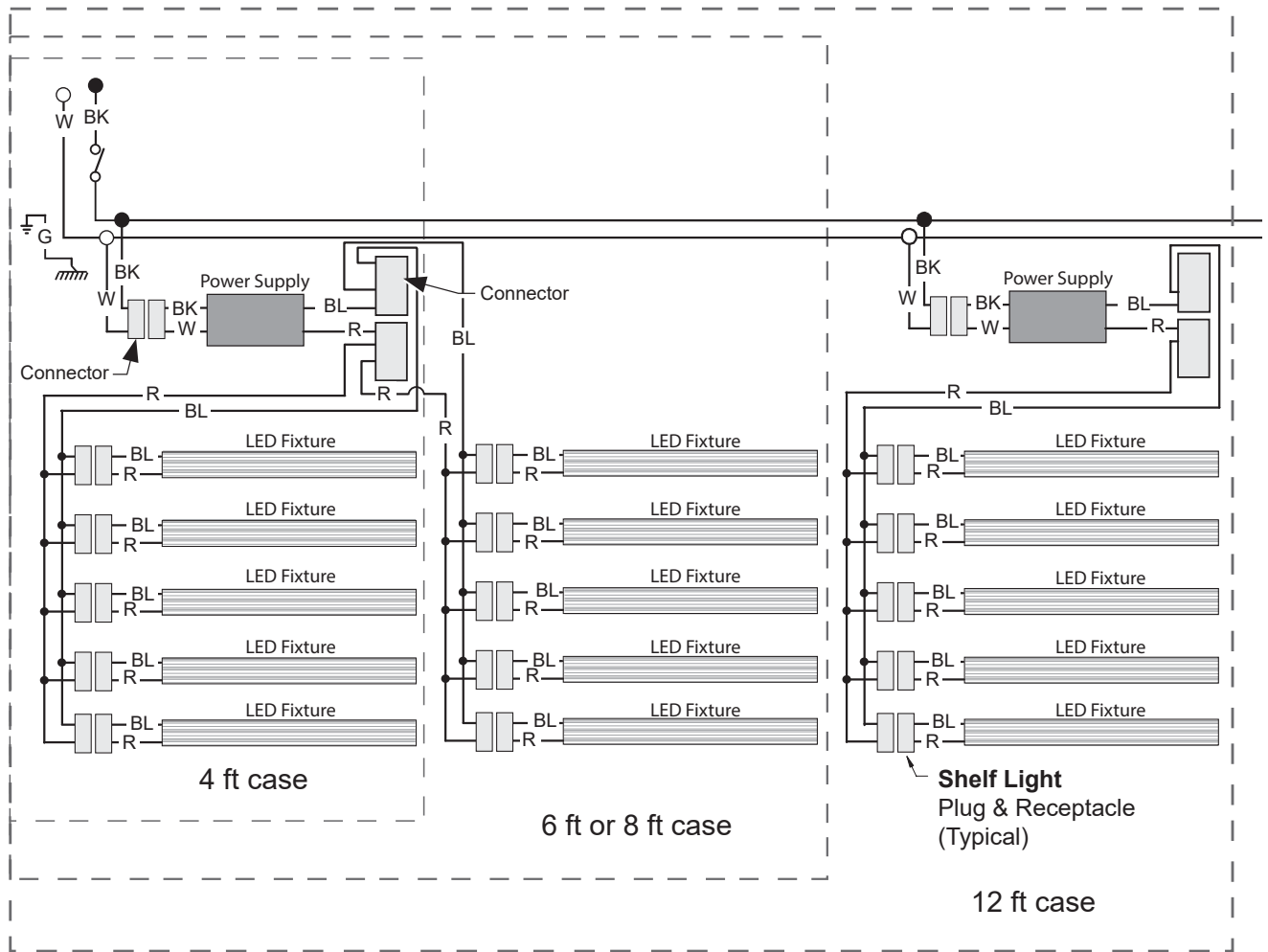

**WARNING**

All components must have mechanical ground, and the merchandiser must be grounded.

R = Red    Y = Yellow    G = Green    BL = Blue    BK = Black    W = White  
 ● = 120V POWER    ○ = 120V NEUTRAL    ⊥ = FIELD GROUND    ≡ = CASE GROUND

**Wiring Diagram (LED shelf light circuits, 6 or 7 rows of shelves)**

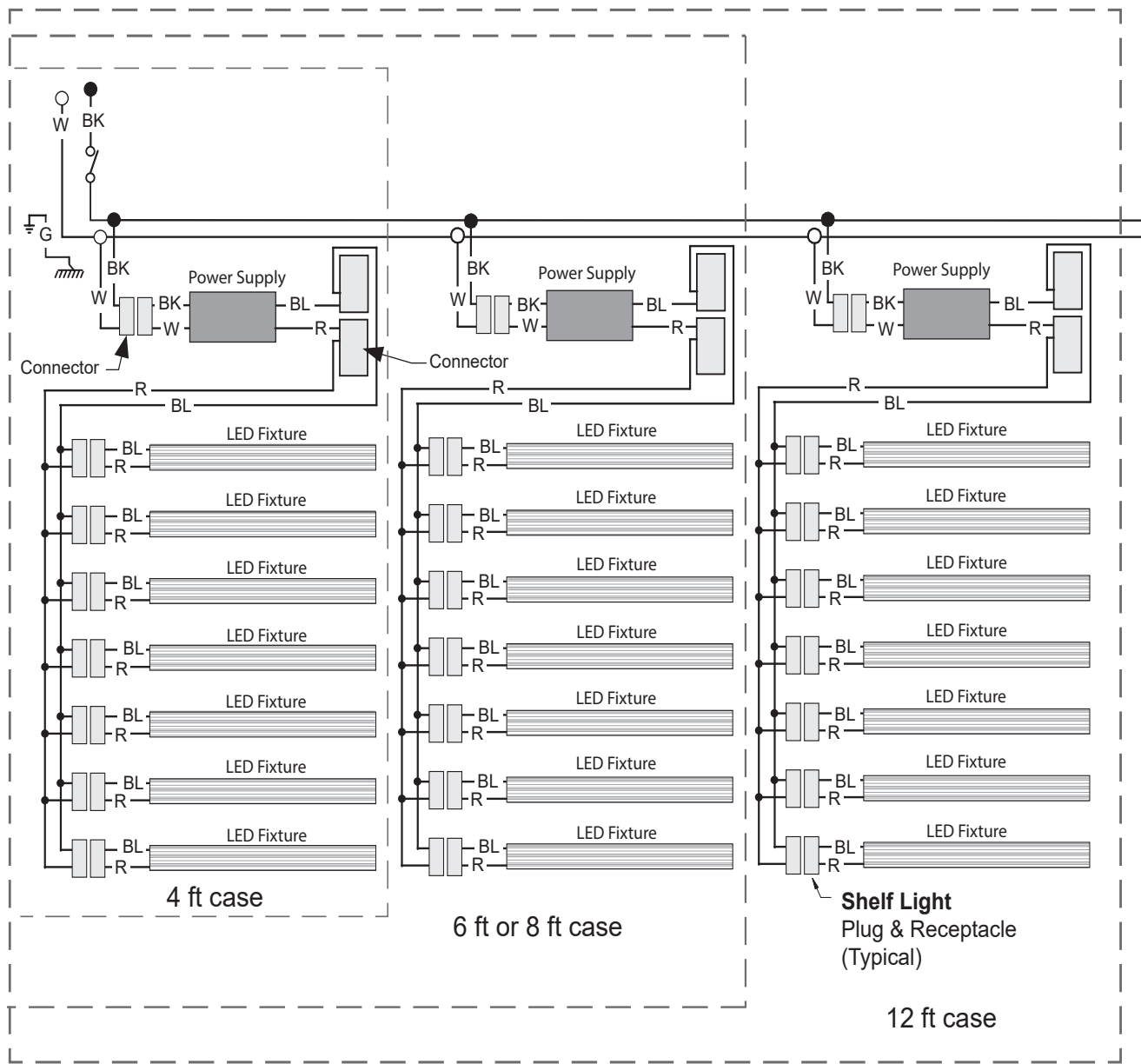

**WARNING**

All components must have mechanical ground, and the merchandiser must be grounded.

R = Red    Y = Yellow    G = Green    BL = Blue    BK = Black    W = White

● = 120V POWER    ○ = 120V NEUTRAL    ⊥ = FIELD GROUND    ≡ = CASE GROUND

**Wiring Diagram (A2L detection and mitigation system)**

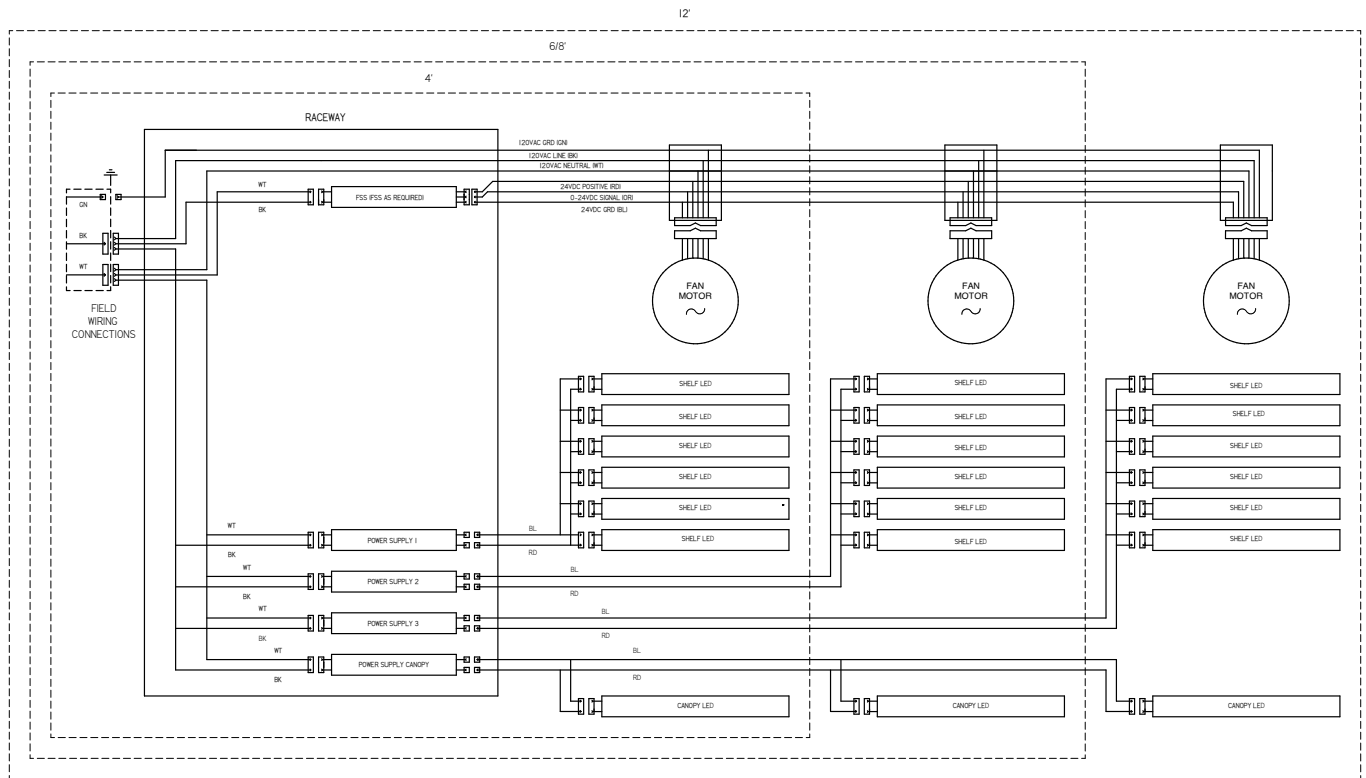

<b>WIRE COLOR</b> <b>UL COLOR CODES / ABBREVIATIONS</b> — RED = RD      — WHITE = WT — BLACK = BK    — GREEN = GN — BLUE = BL      — BROWN = BN — YELLOW = YL   — ORANGE = OR — GRAY = GY     — VIOLET = VT	<b>FACTORY 14GA WIRE</b> _____ <b>FACTORY 10GA WIRE</b> _____ - - - - - <b>FIELD WIRE</b>	<b>HUSSMANN®</b> DIAGRAM-A2L GAS DETECT INSIGHT DANFOSS DO NOT SCALE DRAWING SHEET 1 OF 4	PIN 3220871 REV C
	CP-3.2 WIRE DIAGRAM SIZE: 24.1"		

Wiring Diagram (ID5SL12, A2L detection and mitigation system)

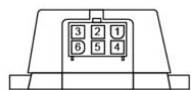
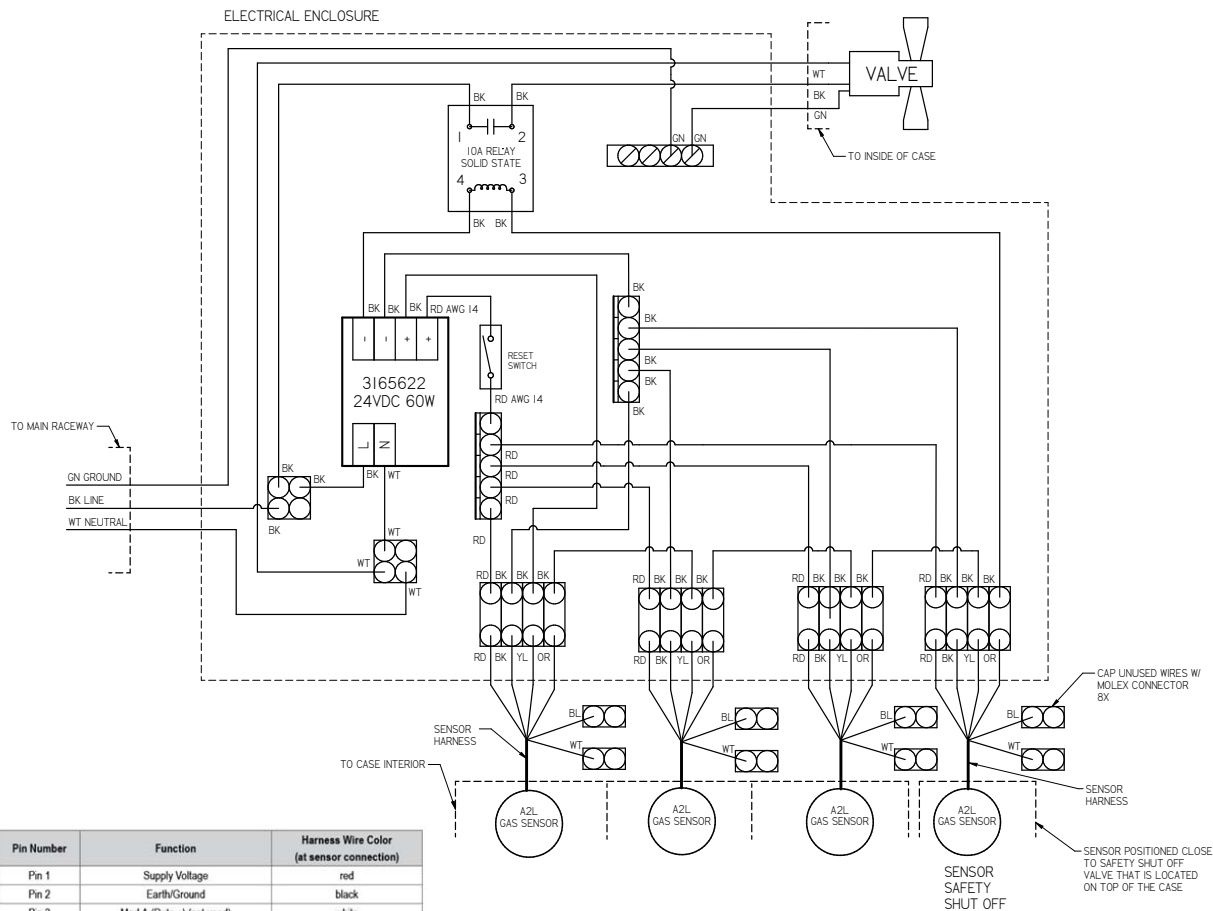

Pin Number	Function	Harness Wire Color (at sensor connection)
Pin 1	Supply Voltage	red
Pin 2	Earth/Ground	black
Pin 3	Mod A (Data +) (not used)	white
Pin 4	Mod B (Data -) (not used)	blue
Pin 5	Input Relay	yellow
Pin 6	Normally Open Contacts Output	orange

Relay Operation

- Relay is energized on power up when not in alarm state
- Relay is de-energized in alarm or no power state

WIRE COLOR UL COLOR CODES / ABBREVIATIONS	FACTORY 14GA WIRE	<b>HUSSMANN</b> DIAGRAM-A2L GAS DETECT INSIGHT DANFOSS PIN 3220871 REV C
— RED = RD      — WHITE = WT — BLACK = BK    — GREEN = GN — BLUE = BL     — BROWN = BN — YELLOW = YL   — ORANGE = OR — GRAY = GY    — VIOLET = VT	— — — — — FACTORY 10GA WIRE — — — — — FIELD WIRE	
DO NOT SCALE DRAWING SHEET 2 OF 4		

**Wiring Diagram (ID5SL6 / ID5SL8, A2L detection and mitigation system)**

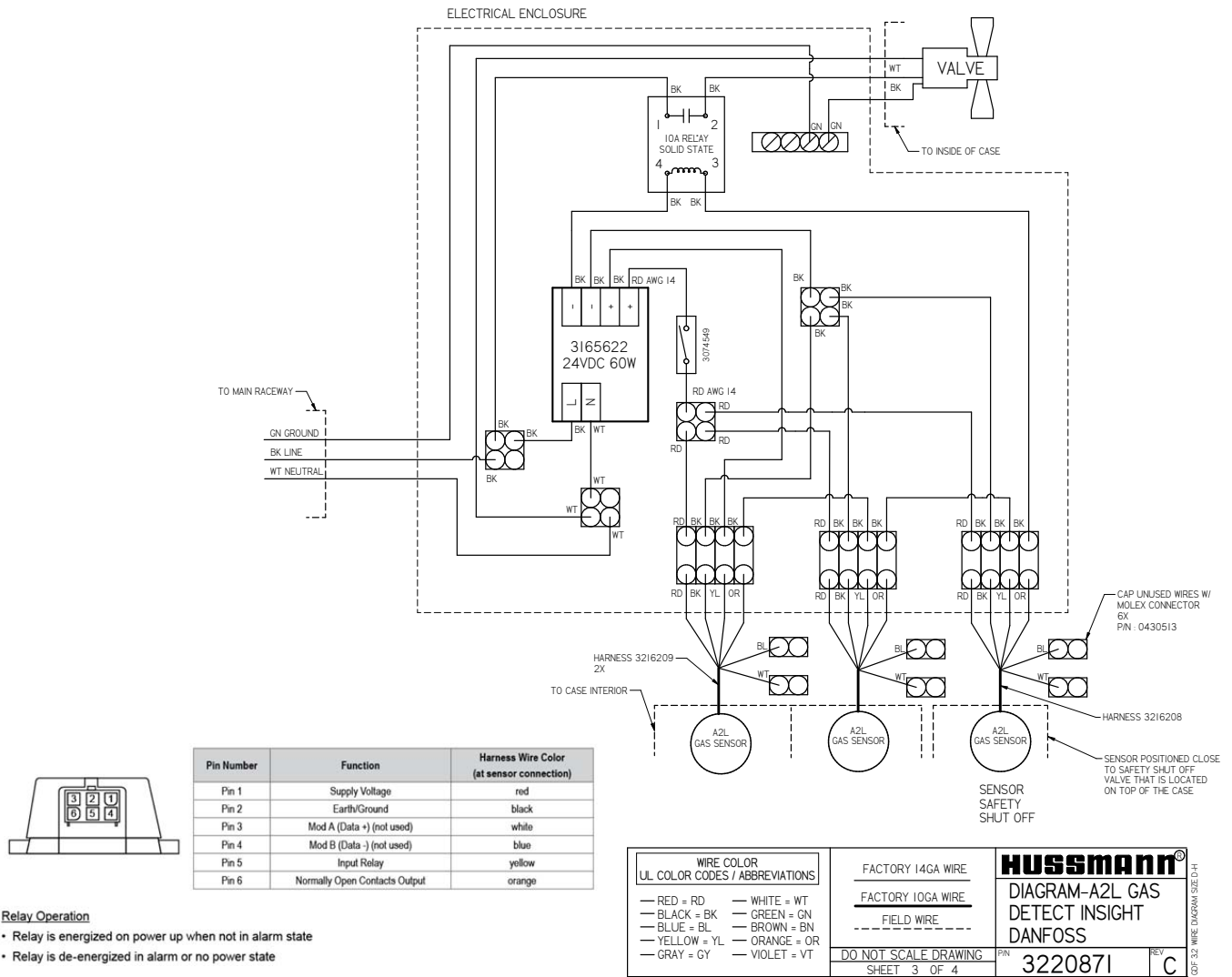

**Wiring Diagram (ID5SL4, A2L detection and mitigation system)**

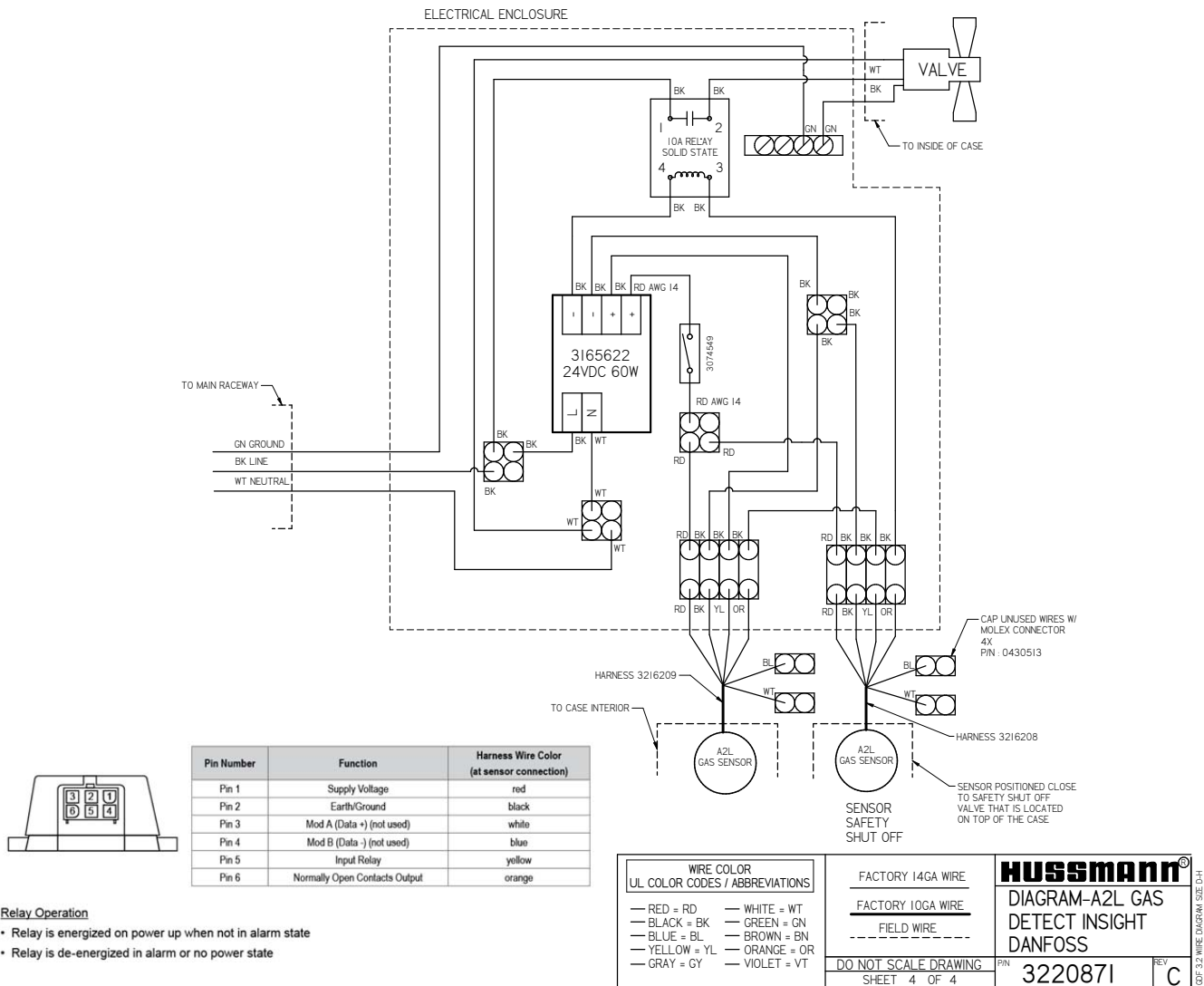

**Relay Operation**

- Relay is energized on power up when not in alarm state
- Relay is de-energized in alarm or no power state

**Notes:**

---

## DS\_ID5SL\_0535977\_R\_EN

### Revision History

Revision L: (January 2019) Removed light notes.

Revision M: (July 2019) Updated parts list, lighting and CaseShieldPTM.

Revision N: (January 2023) Added CO<sub>2</sub> note, Page 2.

Revision P: November 2023: Updated fan and lighting information.

Revision R: (February 2026) Updated format and added A2L, CO<sub>2</sub>, and glycol information.



Scan the QR code on your mobile device to access additional product information or order parts.

Parts may also be ordered at:

[parts.hussmann.com](https://parts.hussmann.com)

Call toll free: 1.855.487.7778

We reserve the right to change or revise specifications and product design in connection with any feature of our products. Such changes do not entitle the buyer to corresponding changes, improvements, additions or replacements for equipment previously sold or shipped.