



ID6SU12 shown

## **Technical Datasheet**

### **ID6SU**

Open Multideck Medium  
Temperature Display Case

#### **Applications**

Beverage, Dairy, Deli, Meat, Produce

**P/N 0541494 Rev R**

February 2026

#### **Models Covered**

ID6SU4, ID6SU6,  
ID6SU8, ID6SU12

#### **Refrigerant(s)**

A2L (R-454A or R-454C)

R-744 (CO<sub>2</sub>)

Glycol

HFC/HCFC/HFO

## **Certifications**



**Intertek**

### **NSF/Sanitation Compliance**

This merchandiser model is manufactured to meet NSF/ANSI Standard 7 requirements for construction, materials, and cleanability.

**⚠ WARNING**

**Component parts shall be replaced with like components, and servicing shall be done by factory authorized service personnel only, so as to minimize the risk of possible ignition due to incorrect parts or improper service.**

## **Table of Contents**

Model Name	2
Performance Data	3
Refrigerant Data	4
Additional Data	5
Cross-section View	6
Plan View	7
Estimated Shipping Weight	9
Electrical Specifications	10
Wiring Diagrams	11

We reserve the right to change or revise specifications and product design in connection with any feature of our products. Such changes do not entitle the buyer to corresponding changes, improvements, additions, or replacements for equipment previously sold or shipped.

**WARNING:**

Read the entire installation, operation, and service manual before installing, servicing, or using this equipment in any way. Refer to the manual for detailed information about minimum room floor area and installation, maintenance, and service processes.

**A2L Equipped Models**

If the information in the instructions are not followed exactly, a fire or explosion may result, causing property damage, personal injury, or death. Installation and service must be performed by a qualified installer or service agency.



Mildly flammable A2L refrigerant used. Units that are configured to use A2L refrigerants require special attention. No open flames, cigarettes, or other possible sources of ignition should be used inside or in the vicinity of units containing flammable refrigerants.

If a refrigerant leak is present or even suspected, do not allow untrained personnel to attempt to find the cause. No open flames, cigarettes, or other possible sources of ignition should be used inside or in the vicinity of the unit(s). Intrinsically safe components are the only types that can be worked on while live in the presence of a flammable atmosphere.

Information on pre-installed A2L refrigerant sensors and detectors, safety shut-off and check valves, relay information, and additional parts replacement information can be found in the associated installation, operation, and service manual. All manual information must be reviewed in full prior to performing any work.

**R-744 (CO<sub>2</sub>) Equipped Models**

This equipment uses carbon dioxide (R-744 [CO<sub>2</sub>]) refrigerant for heat transfer. The system is sealed and pressure-tested with ASME-certified vessels, but leaks can occur in the event of a system failure. A CO<sub>2</sub> leak in an unventilated space can pose serious hazards. Therefore, units must be installed in areas with adequate ventilation and in accordance with local safety codes.

A leak of R-744 could result in a concentration exceeding the practical limit in an enclosed, occupied space such as a cold room. Precautions must be taken to prevent asphyxiation. These include the use of permanent leak detection, which activates an alarm in the event of a leak.



Observe all warnings and labels on the unit being installed or serviced such as the one below indicating high pressure.

All refrigeration servicing must be completed by a certified refrigeration installation professional, and all tubing and components MUST be qualified for CO<sub>2</sub> applications, with a minimum design pressure of 1,305 psig (90 bar).

**Failure to abide by all warnings contained within the associated manual could result in an explosion, death, injury, and property damage.**

**Model Nomenclature**

“ID6SU” is followed by a number representing the length of the case in feet (i.e., a 12-foot model would be “ID6SU12”).

**Ordering Information**

All options must be selected at time of ordering. Some lengths and/or applications require optional fan motor kits applied by the Hussmann Product Configurator (HPC).

**Performance Data<sup>A</sup>**

Data Type		Beverage/Dairy/ Deli/Produce	Convertible/Meat	NSF II Ambient <sup>c</sup>	Pegboard <sup>d</sup>
		NSF I Ambient	NSF I Ambient		NSF I Ambient
Unlit Shelves	Discharge Air Temperature	33° F (0.6° C)	32° F (0° C)	33° F (0.6° C)	32° F (0° C)
	Evaporator Temperature <sup>b</sup>	28° F (-2.2° C)	26° F (-3.3° C)	26° F (-3.3° C)	26° F (-3.3° C)
	Parallel Capacity per Foot (meter)	1,545 BTU/h (1,486 W)	1,705 BTU/h (1,640 W)	2,063 BTU/h (1,984 W)	1,998 BTU/h (1,921 W)
	Conventional Capacity per Foot (meter)	1,685 BTU/h (1,621 W)	1,860 BTU/h (1,788 W)	2,250 BTU/h (2,164 W)	2,180 BTU/h (2,097 W)
Lit Shelves	Discharge Air Temperature	32° F (0° C)	32° F (0° C)	33° F (0.6° C)	N/A
	Evaporator Temperature <sup>b</sup>	27° F (-2.8° C)	25° F (-3.9° C)	25° F (-3.9° C)	N/A
	Parallel Capacity per Foot (meter) <sup>f</sup>	1,570 BTU/h (1,510 W)	1,714 BTU/h (1,648 W)	2,072 BTU/h (1,993 W)	N/A
	Conventional Capacity per Foot (meter) <sup>f</sup>	1,710 BTU/h (1,645 W)	1,870 BTU/h (1,799 W)	2,260 BTU/h (2,173 W)	N/A
Fan Speed <sup>h</sup>	10.3 in (262 mm)	1,300 RPM	1,600 RPM	1,600 RPM	1,600 RPM
AHRI Rating <sup>e</sup> (NSF I ambient)	Unlit Shelves	Discharge Air Temperature		35° F (1.7° C)	
		Evaporator Temperature <sup>b</sup>		30° F (-1.1° C)	
		Parallel Capacity per Foot (meter)		1,490 BTU/h (1,433 W)	
		Conventional Capacity per Foot (meter)		1,625 BTU/h (1,562 W)	
	Lit Shelves	Discharge Air Temperature		34° F (1.1° C)	
		Evaporator Temperature <sup>b</sup>		29° F (-1.7° C)	
		Parallel Capacity per Foot (meter)		1,515 BTU/h (1,457 W)	
		Conventional Capacity per Foot (meter)		1,650 BTU/h (1,587 W)	
Fan Speed <sup>h</sup>		10.3 in (262 mm)		1,300	
Low Pressure Backup Control (CI/CO) <sup>g</sup>		20° F (-6.7° C) / 10° F (-12.2° C)			

<sup>A</sup> All data based on store temperature and humidity that does not exceed NSF Type I ambient conditions of 75° F (23.9° C) and 55% relative humidity, except where noted. Reduce refrigeration load by 15% if fitted with CaseShieldPTM.

<sup>B</sup> Average evaporator temperature shown. Use dew point for high-glide refrigerants for unit sizing. Care should be taken to use the dew point in PT (pressure-temperature) tables for measuring and adjusting superheat. Adjust evaporator pressure as needed to maintain discharge air temperature shown.

For DX R-744 (CO<sub>2</sub>) applications, the average evaporator temperature may be lowered by 2° F (1.1° C), but not more than 5° F (2.8° C).

An EPR valve should be used if the system suction temperature is more than 5° F (2.8° C) below the published case evaporator temperature. A 31° F (-0.6° C) flash tank temperature with a 24° F (-4.4° C) evaporator temperature is used when sizing default EEV selections to provide a minimum pressure drop across the valve of approximately 50 PSIG (3.4 bar). For operating conditions that provide a pressure drop across the valve above 65 PSIG (4.5 bar) or below 35 PSIG (2.4 bar), the EEV size should be determined using the valve vendor sizing program and selected from the pull down list in the Hussmann Product Configurator (HPC).

<sup>C</sup> NSF Type II ambient conditions of 80° F (26.7° C) and 55% relative humidity.

<sup>D</sup> Hussmann peg shelves for dairy and deli applications only.

<sup>E</sup> AHRI 1200 rating point for energy consumption comparison only.

<sup>F</sup> Add 10 BTU/h/ft (9.6 W/m) per shelf row for LED shelf light fixtures.

<sup>G</sup> Use a temperature pressure chart to determine PSIG (bar) conversions.

<sup>H</sup> Some lengths and/or applications require optional fan motor kits applied by the Hussmann Product Configurator (HPC).

**Performance Data (cont.)**

**Defrost Data**

Frequency	4 hours between defrost cycles
Time	20 minutes
Temp. Termination	N/A
Defrost Type	offtime
Defrost Water <sup>l</sup>	10.3 lb/ft/day (15.3 kg/m)

**Product Data**

Gross Refrigerated Volume <sup>j</sup>	13.2 ft <sup>3</sup> /ft of length (1.23 m <sup>3</sup> /m of length)
AHRI Total Display Area <sup>k</sup>	5.55 ft <sup>2</sup> /ft of length (1.69 m <sup>2</sup> /m of length)
Shelf Surface Area <sup>l</sup>	11.69 ft <sup>2</sup> /ft of length (3.56 m <sup>2</sup> /m of length)

**Refrigerant Data**

**Approximate HFC/HCFC/HFO Refrigerant Charge**

Case	Estimated Charge <sup>m</sup>
ID6SU4	11.2 oz (318 g)
ID6SU6	19.2 oz (544 g)
ID6SU8	25.6 oz (726 g)
ID6SU12	49.6 oz (1,406 g)

**A2L Refrigerant Charge**

Model	Minimum Room Floor Area ft <sup>2</sup> (m <sup>2</sup> )	Estimated Refrigerant Charge— lb (g)	
		Operating Charge	
		R-454A	R-454C
ID6SU4	106 (9.8)	1.6 (728)	1.6 (728)
ID6SU6	106 (9.8)	2.2 (990)	2.2 (990)
ID6SU8	196 (18.2)	2.8 (1,269)	2.8 (1,269)
ID6SU12	196 (18.2)	4.1 (1,866)	4.1 (1,866)

**R-744 (CO<sub>2</sub>) Pressure Rating**

Case Configuration	Pressure Rating
standard pressure CO <sub>2</sub>	600 psi (41.4 bar)
high pressure CO <sub>2</sub>	1,305 psi (90 bar)

<sup>l</sup> (± 15% based on case configuration and product loading).

<sup>j</sup> AHRI Gross Refrigerated Volume: Refrigerated Volume/Unit of Length, ft<sup>3</sup>/ft [m<sup>3</sup>/m]

<sup>k</sup> Computed using AHRI 1200 standard methodology: Total Display Area, ft<sup>2</sup> [m<sup>2</sup>]/Unit of Length, ft [m]

<sup>l</sup> Shelf surface area is composed of bottom deck plus standard shelf complement for this model: (5) rows of 22-in. shelves

<sup>m</sup> This is an average for all refrigerant types. Actual refrigerant charge may vary by approximately half a pound.

**Glycol Heat Transfer Fluid Data (Dairy, Deli)**

Model	Conventional Load BTU/h/ft (W/m)	Discharge Air Temperature ° F (° C)	Coil Inlet Temperature ° F (° C)	Coil Temp. Rise ° F (° C)	Average Coil Temperature ° F (° C)	Flow Rate GPM (LPM)	Pressure Drop PSI (bar)
ID6SU4	1,760 (1,691)	32 (0)	25 (-3.9)	4 (2.2)	27 (-2.8)	3.8 (14.4)	12.6 (0.9)
			20 (-6.7)	12 (6.7)	26 (-3.3)	1.3 (4.9)	3.3 (0.2)
ID6SU6	1,760 (1,691)	32 (0)	25 (-3.9)	4 (2.2)	27 (-2.8)	5.7 (21.6)	8.6 (0.6)
			20 (-6.7)	12 (6.7)	26 (-3.3)	1.9 (7.2)	2.3 (0.2)
ID6SU8	1,760 (1,691)	32 (0)	25 (-3.9)	4 (2.2)	27 (-2.8)	7.6 (28.8)	14.7 (1.0)
			20 (-6.7)	12 (6.7)	26 (-3.3)	2.5 (9.5)	4.0 (0.3)
ID6SU12	1,760 (1,691)	32 (0)	25 (-3.9)	4 (2.2)	27 (-2.8)	11.4 (43.2)	15.0 (1.0)
			20 (-6.7)	12 (6.7)	26 (-3.3)	3.8 (14.4)	4.2 (0.3)

**Glycol Heat Transfer Fluid Data (Meat)**

Model	Conventional Load BTU/h/ft (W/m)	Discharge Air Temperature ° F (° C)	Coil Inlet Temperature ° F (° C)	Coil Temp. Rise ° F (° C)	Average Coil Temperature ° F (° C)	Flow Rate GPM (LPM)	Pressure Drop PSI (bar)
ID6SU4	1,870 (1,796)	30 (-1.1)	25 (-3.9)	4 (2.2)	27 (-2.8)	4.1 (15.5)	13.7 (0.9)
			20 (-6.7)	10 (5.6)	25 (-3.9)	1.6 (6.1)	4.6 (0.3)
ID6SU6	1,870 (1,796)	30 (-1.1)	25 (-3.9)	4 (2.2)	27 (-2.8)	6.1 (23.1)	9.5 (0.7)
			20 (-6.7)	10 (5.6)	25 (-3.9)	2.5 (9.5)	3.2 (0.2)
ID6SU8	1,870 (1,796)	30 (-1.1)	25 (-3.9)	4 (2.2)	27 (-2.8)	8.1 (30.7)	15.9 (1.1)
			20 (-6.7)	10 (5.6)	25 (-3.9)	3.3 (12.5)	5.5 (0.4)
ID6SU12	1,870 (1,796)	30 (-1.1)	25 (-3.9)	4 (2.2)	27 (-2.8)	12.2 (46.2)	16.2 (1.1)
			20 (-6.7)	10 (5.6)	25 (-3.9)	4.9 (18.5)	5.7 (0.4)

**Cross-Section View**

Standard shelf complement shown as tested—five rows of 22 in. (559 mm) shelves spaced equally between bottom display pan and interior top panel. 1 1/2 in. (38 mm) spacing is required behind the merchandiser between a surface such as a wall or other cases.

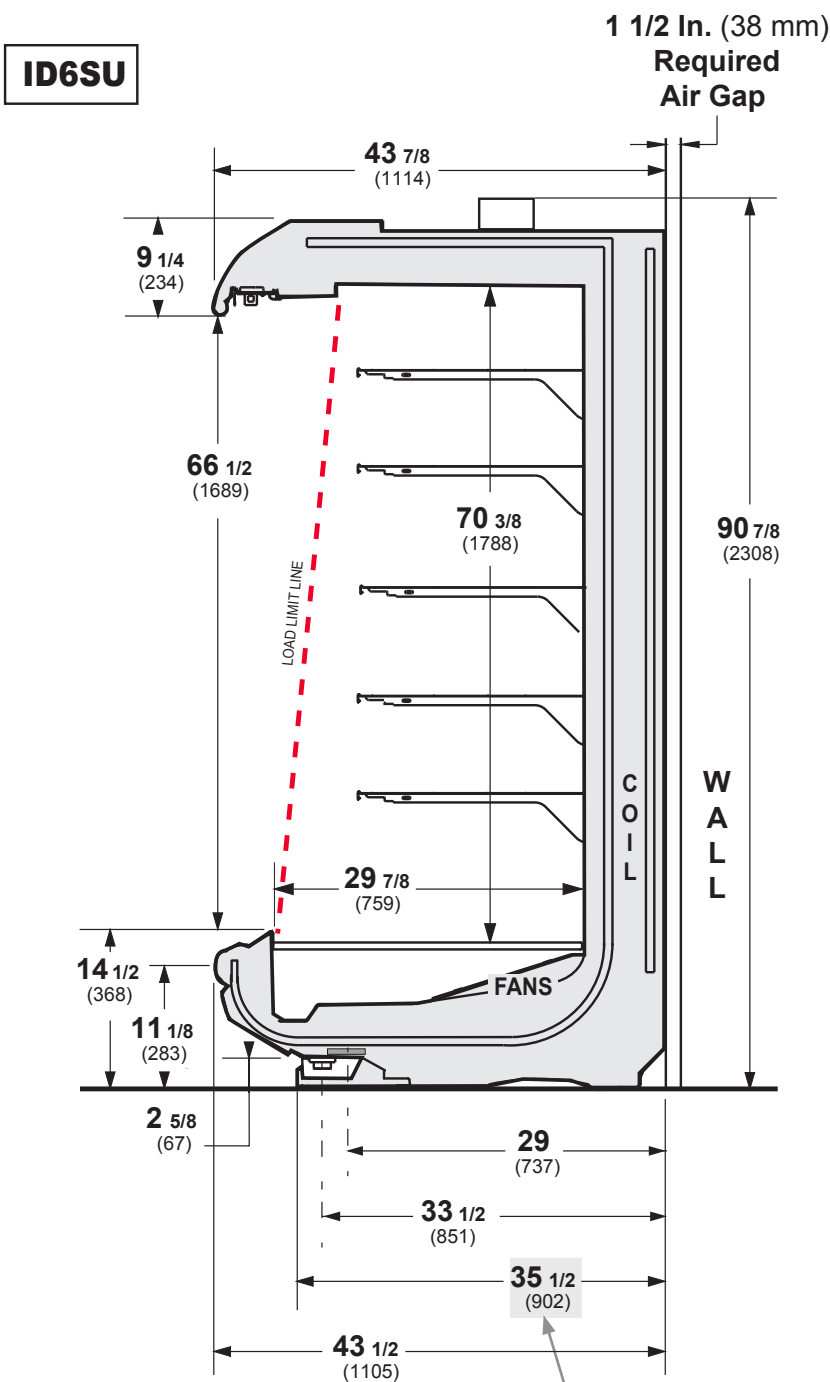

Shown with ellipse option canopy and bumper.

A minimum 1 1/2 in. (38 mm) clearance required to remove raceway cover, 6 1/2 in. (165 mm) for full access. See the installation manual for additional information.

Other optional kits (top piping and vent fans) add to the overall case height.

**OPTIONAL RAIL LIGHT**

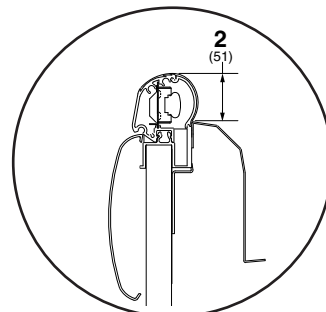

**NOTE:** If extended drain kits are used, the distance from back of case (not including air gap) increases to 41 in. (1,041 mm). This may affect floor drain layout. See plan view for more details.

dimensions shown as in. (mm)

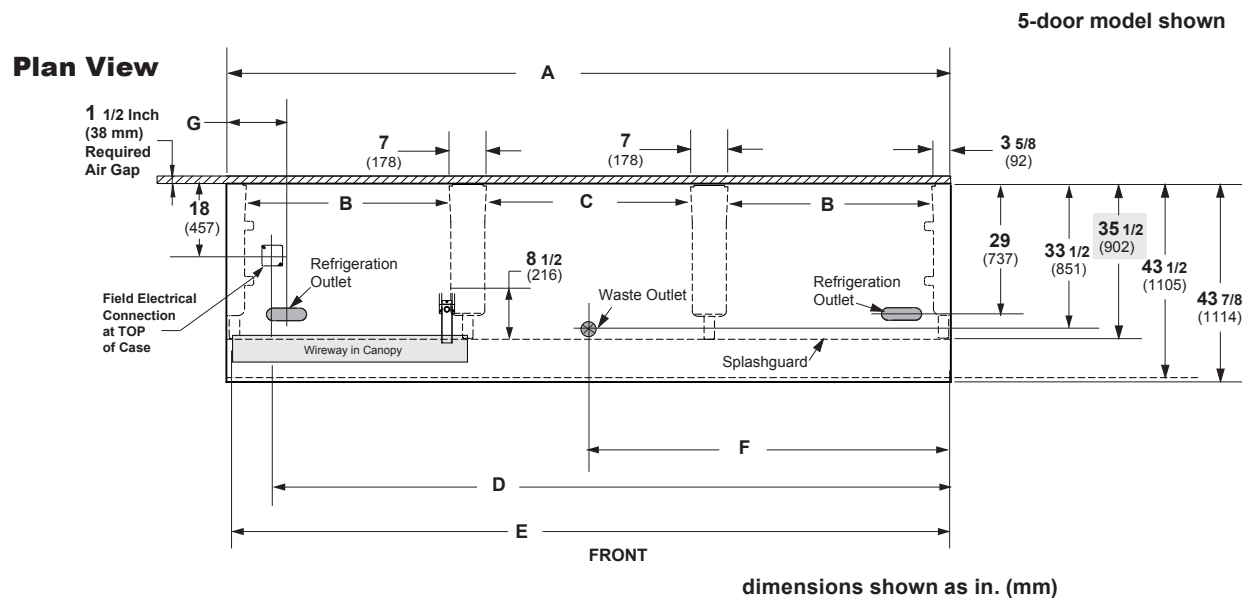

**IMPORTANT:** Drain extension kit required to pipe multiple cases to one drain or to use a raised hub drain.

**WARNING:** Floor drain must be located within 24 in. (610 mm) of waste outlet. Drain extension option shown on next page must be used with hub-style floor drains.

Dimension		ID6SU4	ID6SU6	ID6SU8	ID6SU12
General	<b>A</b> — case length (without ends or partitions) <sup>N</sup>	48 1/8 (1,222)	72 1/4 (1,835)	96 1/4 (2,445)	144 3/8 (3,668)
	maximum o/s dimension of case back to front (includes bumper)	43 1/2 (1,105)			
	back of case to front of splashguard	35 1/2 (902)			
	<b>B</b> — distance between edges of external legs and center legs	N/A	29 (737)	41 (1,041)	41 (1,041)
	<b>C</b> — distance between edges of center legs	41 1/8 (1,045)	N/A	N/A	41 1/8 (1,045)
	distance between front legs and splashguard	8 (203)			
Electrical Service <sup>O</sup>	<b>D</b> — RH end of case to center of field electrical wiring connection (top of case)	39 3/8 (1,000)	63 1/2 (1,613)	87 1/2 (2,223)	135 1/2 (3,442)
	back of case to center of field electrical wiring connection	18 (457)			
	length of electrical wireway	44 5/8 (1,133)	33 1/2 (851)	45 7/8 (1,165)	45 7/8 (1,165)
	<b>E</b> — RH end of case to LH end of electrical wireway (top of case)	46 1/2 (1,181)	70 1/2 (1,791)	94 1/2 (2,400)	142 5/8 (3,630)
Waste Outlets <sup>P</sup>	<b>F</b> — RH end of case to the center of outlet	24 1/8 (613)	24 1/8 (613)	24 1/8 (613)	72 1/4 (1,835)
	back outside of case to center of outlet(s)	33 1/2 (851)			
	schedule 40 PVC drip pipe	1 1/4 (32)			
Refrigeration Outlet	<b>G</b> — back of case to center of outlet	29 (737)			
	end of case to center of outlet	8 1/2 (216)			

<sup>N</sup> Each solid end adds approximately 1 1/2 in. (38 mm) to length of line up. Each partition adds approximately 1 1/2 in. (38 mm). Case to case joints add approximately 1/8 in. (3 mm) for gasket material. Optional view end with end bumper adds 3 3/4 in. (95 mm)

<sup>O</sup> Electrical field wiring connection point is at terminal block. Not intended for case to case connections.

<sup>P</sup> Field-installed waste outlets, tees, and connectors are shipped with case.

**Plan View (Waste Outlet Drain Extension Option)**

**IMPORTANT**  
DRAIN EXTENSION KIT REQUIRED TO PIPE MULTIPLE CASES TO ONE DRAIN, OR TO USE A RAISED HUB DRAIN.

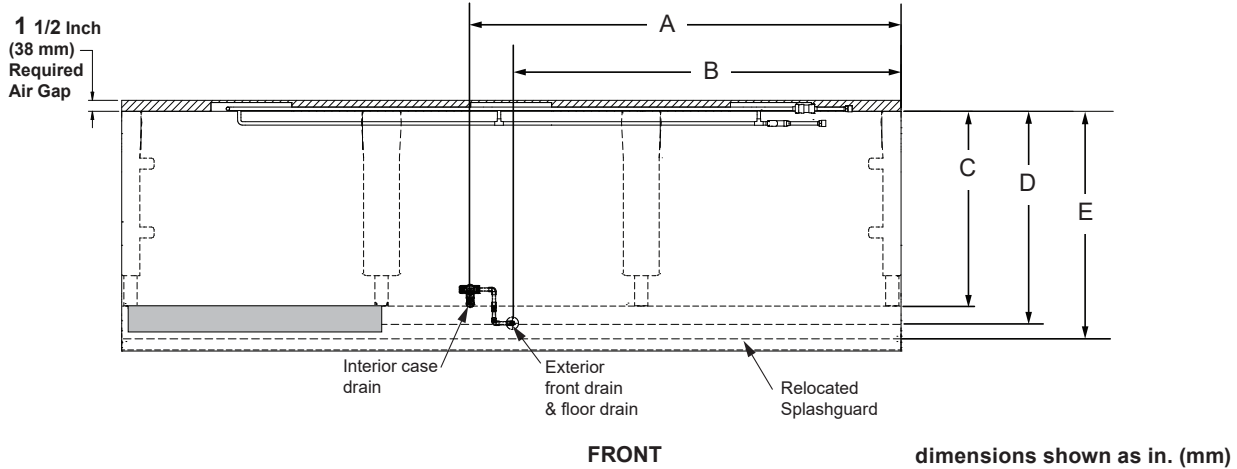

Dimension	ID6SU4	ID6SU6	ID6SU8	ID6SU12
<b>A</b> — RH of case to center of interior case drain	24 1/8 (613)	24 1/8 (613)	24 1/8 (613)	72 1/4 (1,835)
<b>B</b> — RH of case to center of exterior front drain and floor drain (drain extension shown piped to the right but may be either direction)	13 3/4 (349)	13 3/4 (349)	13 3/4 (349)	61 7/8 (1,572)
<b>C</b> — back of case to center of original waste outlet	33 1/2 (851)			
<b>D</b> — back of case to center of relocated waste outlet (with drain extension kit)	38 1/4 (972)			
<b>E</b> — back of case to the back of the relocated splashguard (with drain extension kit)	41 (1,041)			

**Partial End View**

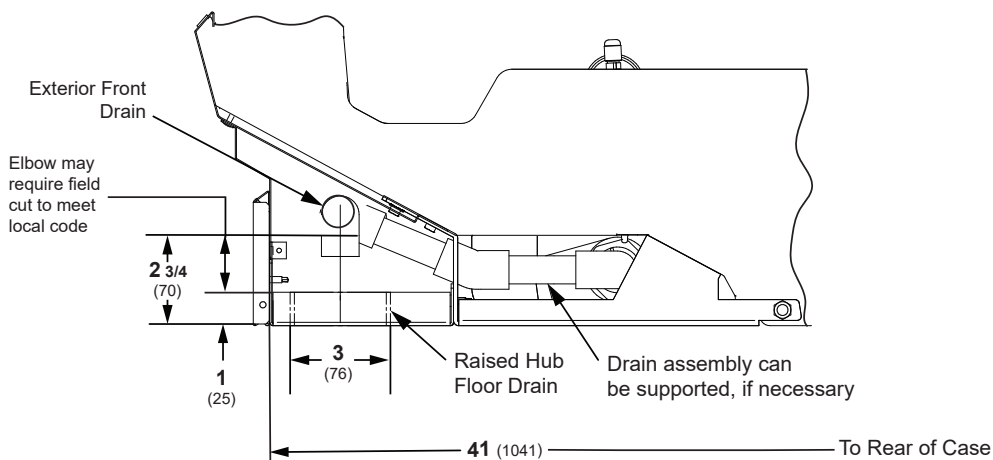

**IMPORTANT:**  
DRAIN EXTENSION KIT REQUIRED TO PIPE MULTIPLE CASES TO ONE DRAIN OR TO USE A RAISED HUB DRAIN

**IMPORTANT:** If the hub drain is used instead of a flush floor sink, a drain extension kit must be installed. Hub drains must be located in front of the waste outlet because of the required air gap.

**Additional Dimensional Data****Ends and Partitions**

Each solid end adds approximately 1 1/2 in. (38 mm) to length of line up. Each partition adds approximately 1 1/2 in. (38 mm). Case to case joints add approximately 1/8 in. (3 mm) for gasket material. Optional view end with end bumper adds 3 3/4 in. (95 mm)

**Drip Pipe, Liquid Line, and Suction Line**

The below values represent only a sample of the most common connection sizes. Consult a Hussmann representative for additional data related to specific case size and refrigerant variations.

<b>Merchandiser Drip Line</b>	1 1/4 in.
<b>Merchandiser Liquid Line</b>	3/8 in.
<b>Merchandiser Suction Line</b>	7/8 in.

**Estimated Shipping Weight<sup>Q</sup>**

<b>ID6SU4</b>	<b>ID6SU6</b>	<b>ID6SU8</b>	<b>ID6SU12</b>	<b>Solid End (each)</b>
900 lb (408 kg)	1,100 lb (499 kg)	1,300 lb (590 kg)	1,700 lb (771 kg)	100 lb (45 kg)

**Shelf Options**

Approved shelf sizes for standard shelves with two or three position brackets in horizontal position are 18 in. (457 mm), 20 in. (508 mm), 22 in. (559 mm), and 24 in. (610 mm). Standard shelf count is five.

Depending on optional configuration, shelf count can range from four to eight shelves (four to seven for lighted shelves). Contact a Hussmann Engineering representative for information on non-standard shelf or display recommendations. Shelves are designed to support the maximum weight load limits as indicated in the table below.

<b>Shelf Depth</b>	<b>Max. Load Limit (at 0° tilt)</b>
18 in. (457 mm)	200 lb (91 kg)
20 in. (508 mm)	250 lb (113 kg)
22 in. (559 mm)	250 lb (113 kg)
24 in. (610 mm)	250 lb (113 kg)

<sup>Q</sup> Actual weight will vary according to optional kits included.

**Electrical Specifications**

Hussmann refrigerated merchandisers configured for sale and use in the United States meet or surpass the requirements of DOE energy efficiency standards. ID6SU4 (4-foot) display cases have one 10.3 in. fan, ID6SU6 (6-foot)/ID6SU8 (8-foot) cases have two 10.3 in. fans, and ID6SU12 (12-foot) have three 10.3 in. fans.

Each case requires an appropriate supply power connection. Standard electrical connections are on top of the case in the electrical box. Refer to the labeling on the unit for the required voltage for that specific configuration.

Fan electrical load for a case comes from multiplying the number of fans by the current draw per fan and is listed as a total value for the case. Lighting may be on a separate circuit, but lighted shelves work similarly, where the number of lighted shelves is multiplied by the current draw of each shelf. Total values per case by configuration are shown for simplicity based on the number of rows of lit shelves.

Refer to store legend to determine number of circuits. Lighting should be specified in store legend. When applicable, fans, anti-sweat heaters, controllers, etc., must all be included in the MCA value. Include lights in the MCA if lights are on same circuit.

**Warning: Terminal block NOT for case-to-case wire connection.**

Case Specifications	Voltage	ID6SU4	ID6SU6	ID6SU8	ID6SU12
Minimum Circuit Ampacity (MCA)	120 VAC	0.60	1.00	1.00	1.4
	230 VAC	0.41	0.62	0.62	0.82
Maximum Over Current Protection (MOPD)	120 VAC	20	20	20	20
	230 VAC	15	15	15	15

Component Specifications		ID6SU4		ID6SU6		ID6SU8		ID6SU12	
Component Type	Input Voltage	Amps	Watts	Amps	Watts	Amps	Watts	Amps	Watts
Evaporator Fan	120 VAC	0.40	24	0.80	48	0.80	48	1.20	72
	230 VAC	0.21	24	0.42	48	0.42	48	0.62	72
Standard Lighting LED Canopy Lights	24 VDC	0.16	19	0.22	27	0.31	38	0.47	57
Optional 2 Rows of Canopy Lights	24 VDC	0.32	38	0.44	54	0.62	76	0.94	114
Optional LED Shelf Lighting per number of shelf rows (1-7)	24 VDC	0.06	7	0.07	9	0.11	13	0.17	20
	24 VDC	0.11	13	0.15	18	0.22	27	0.33	40
	24 VDC	0.17	20	0.22	27	0.33	40	0.50	60
	24 VDC	0.22	27	0.30	36	0.44	53	0.67	80
	24 VDC	0.28	33	0.37	44	0.56	67	0.83	100
	24 VDC	0.33	40	0.44	53	0.67	80	1.00	120
LED Rail Light	24 VDC	0.39	47	0.51	62	0.78	93	1.17	140
LED Rail Light	24 VDC	0.06	7	0.07	9	0.11	13	0.17	20

**Wiring Diagram (LED canopy light circuits)**

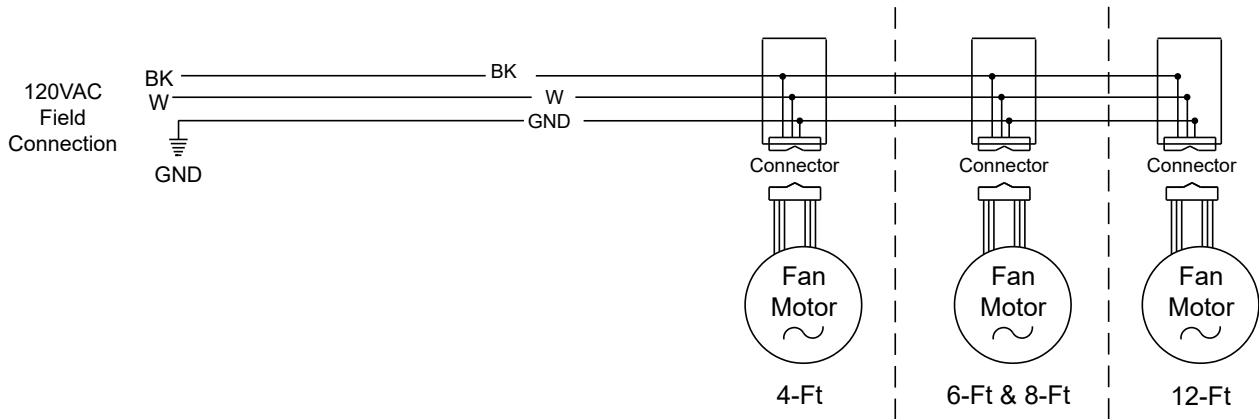

**LED Canopy Lighting - 2 Rows**

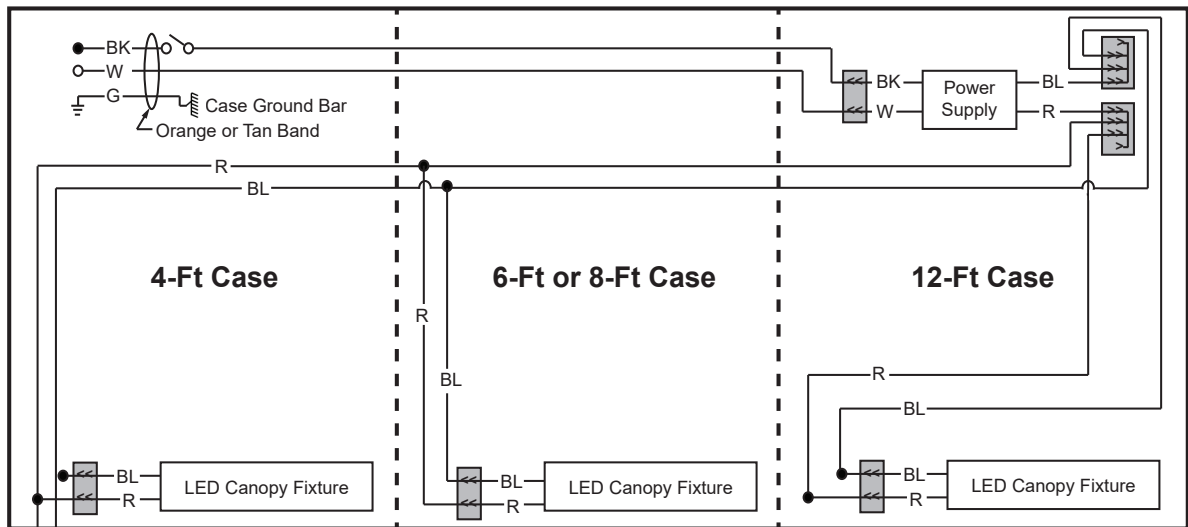

**Optional LED Lighting - LED Rail - 1 Row**

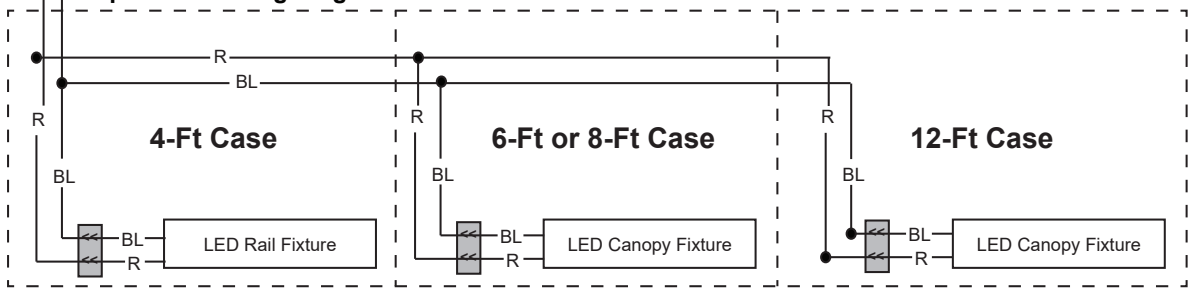

**WARNING**

All components must have mechanical ground, and the merchandiser must be grounded.

R = Red    Y = Yellow    G = Green    BL = Blue    BK = Black    W = White  
 ● = 120V POWER    ○ = 120V NEUTRAL    ⚡ = FIELD GROUND    ⚡ = CASE GROUND

**Wiring Diagram (shelf harness and LED light circuits for 4 and 5 rows of shelves)**

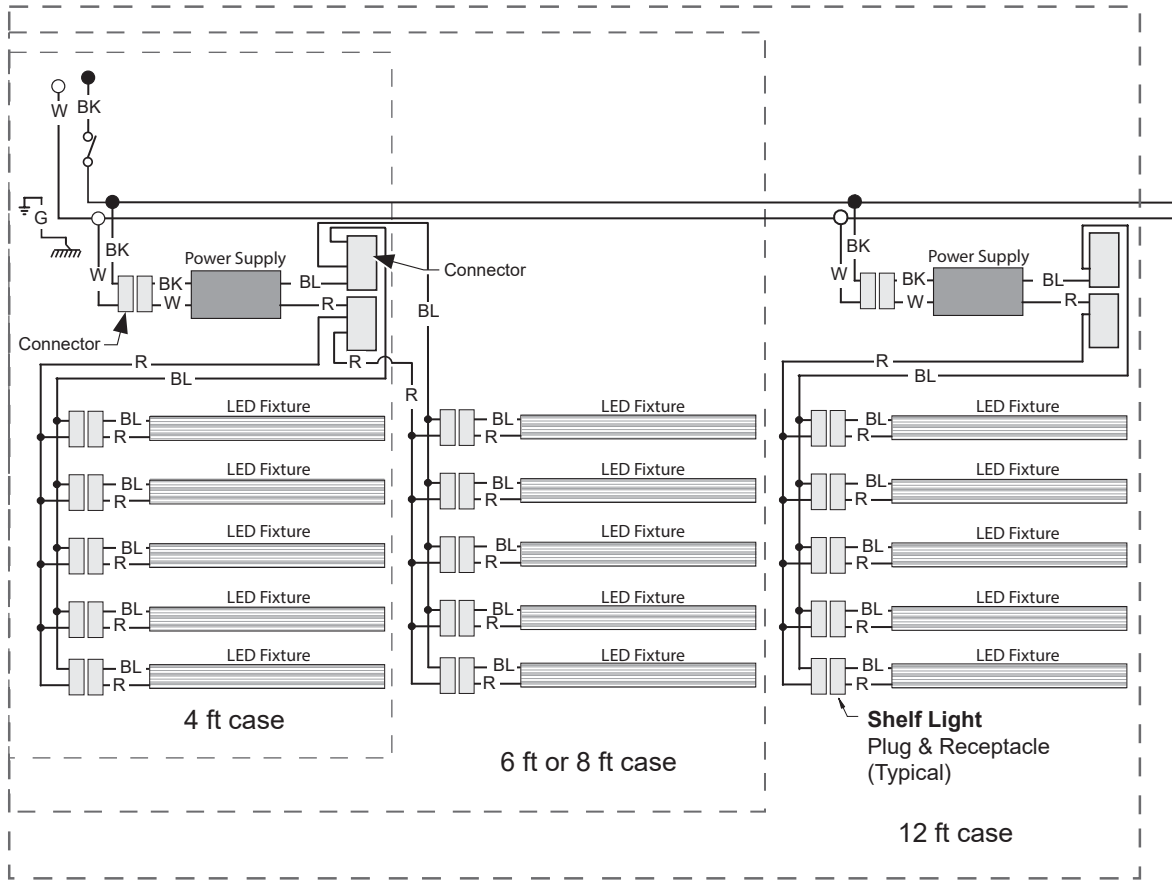

**WARNING**

All components must have mechanical ground, and the merchandiser must be grounded.

R = Red    Y = Yellow    G = Green    BL = Blue    BK = Black    W = White  
 ● = 120V POWER    ○ = 120V NEUTRAL    ⊥ = FIELD GROUND    ≡ = CASE GROUND

**Wiring Diagram (optional shelf lighting for LED fixtures)**

**Shelf Harness and LED Light Circuits for 6 or 7 Rows of Shelves**

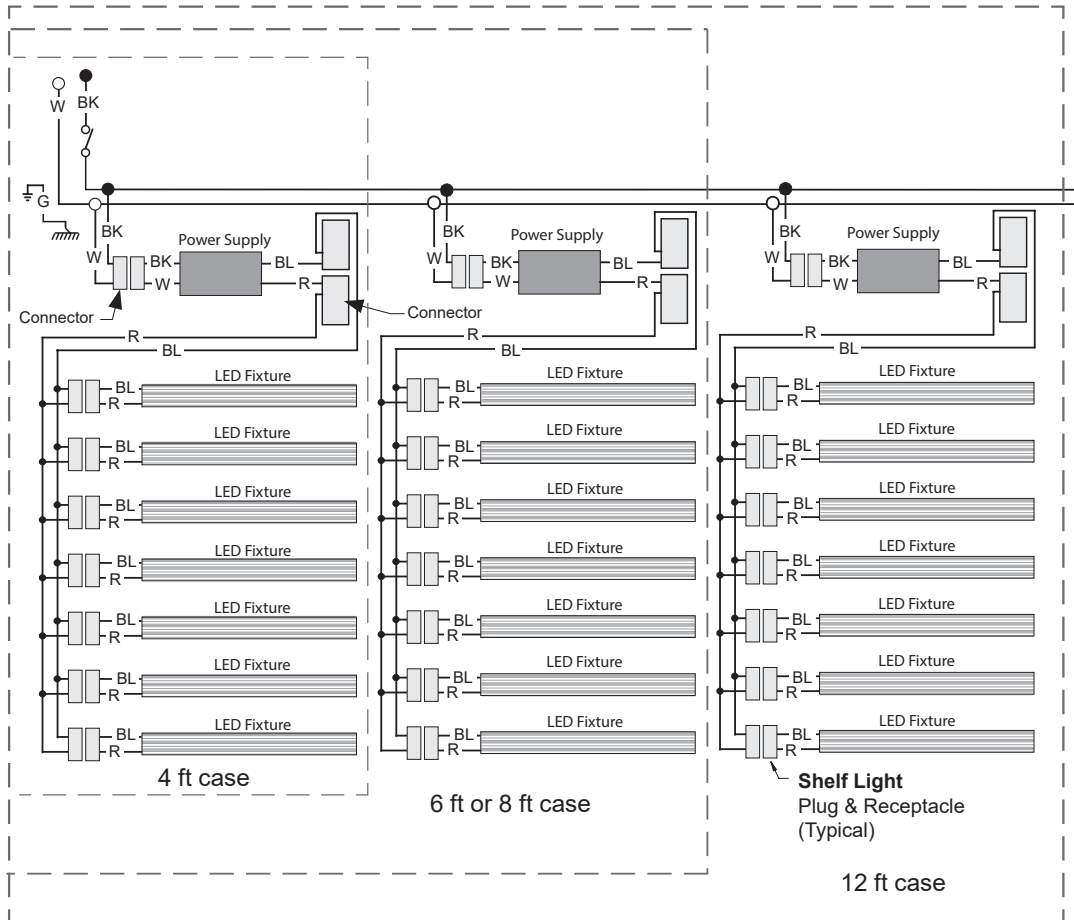

**WARNING**

All components must have mechanical ground, and the merchandiser must be grounded.

R = Red   Y = Yellow   G = Green   BL = Blue   BK = Black   W = White  
 ● = 120V POWER   ○ = 120V NEUTRAL   ⊥ = FIELD GROUND   *mm* = CASE GROUND

Wiring Diagram (A2L detection and mitigation system)

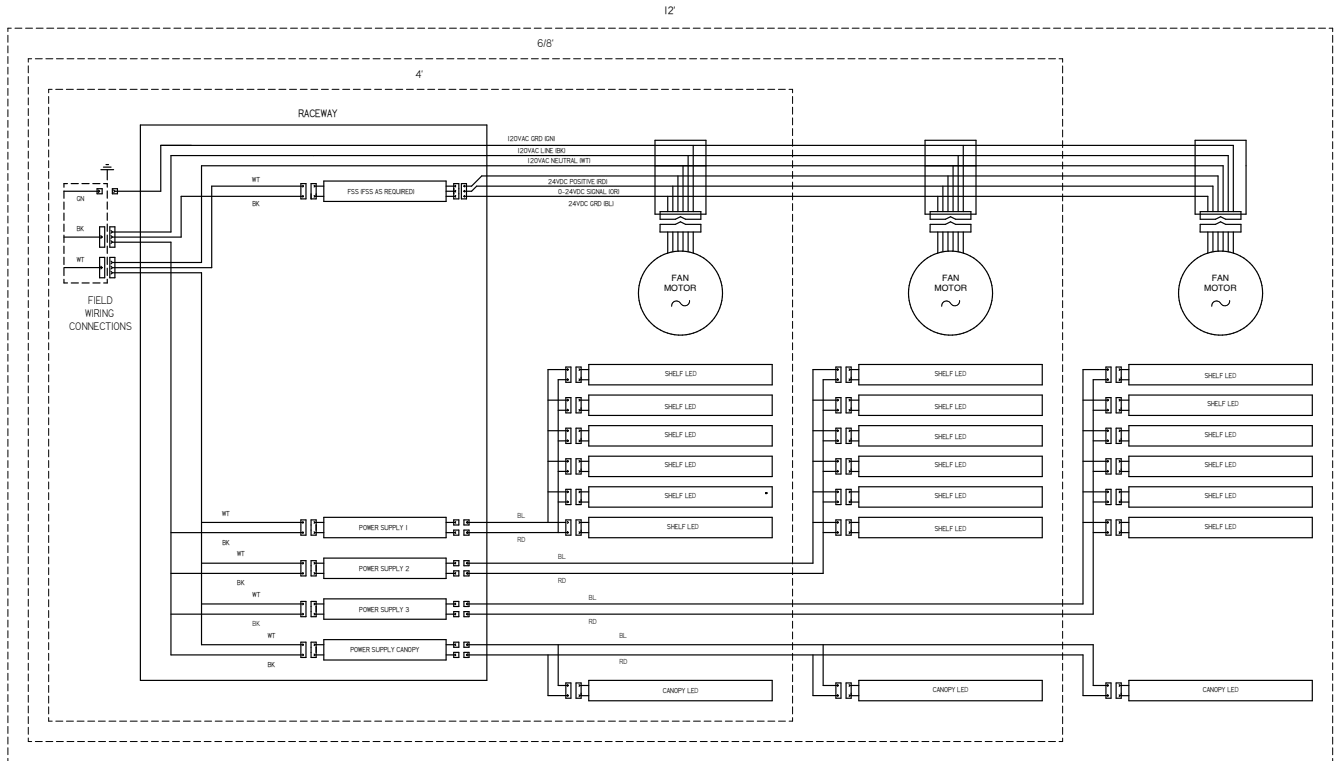

<p>WIRE COLOR UL COLOR CODES / ABBREVIATIONS</p> <p>— RED = RD    — WHITE = WT                  — BLACK = BK    — GREEN = GN                  — BLUE = BL    — BROWN = BN                  — YELLOW = YL    — ORANGE = OR                  — GRAY = GY    — VIOLET = VT</p>	<p>FACTORY 14GA WIRE                  FACTORY 10GA WIRE                  FIELD WIRE</p>	<p><b>HUSSMANN®</b>                  DIAGRAM-A2L GAS                  DETECT INSIGHT                  DANFOSS</p>
<p>DO NOT SCALE DRAWING                  SHEET 1 OF 4</p>	<p>PN 3220871</p>	<p>REV C</p>

**Wiring Diagram (ID6SU12, A2L detection and mitigation system)**

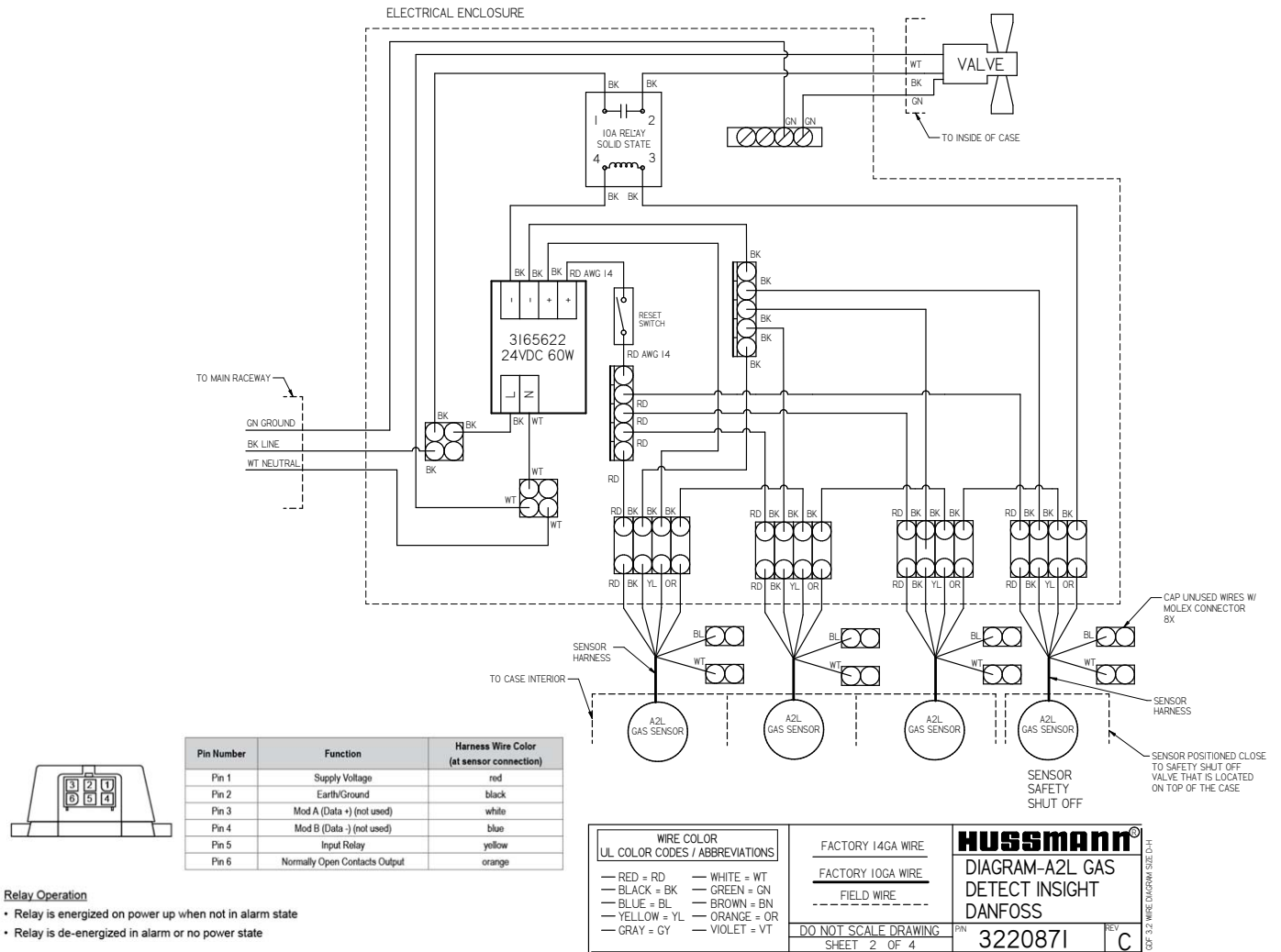

**Wiring Diagram (ID6SU6/ID6SU8, A2L detection and mitigation system)**

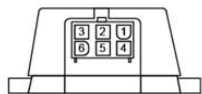
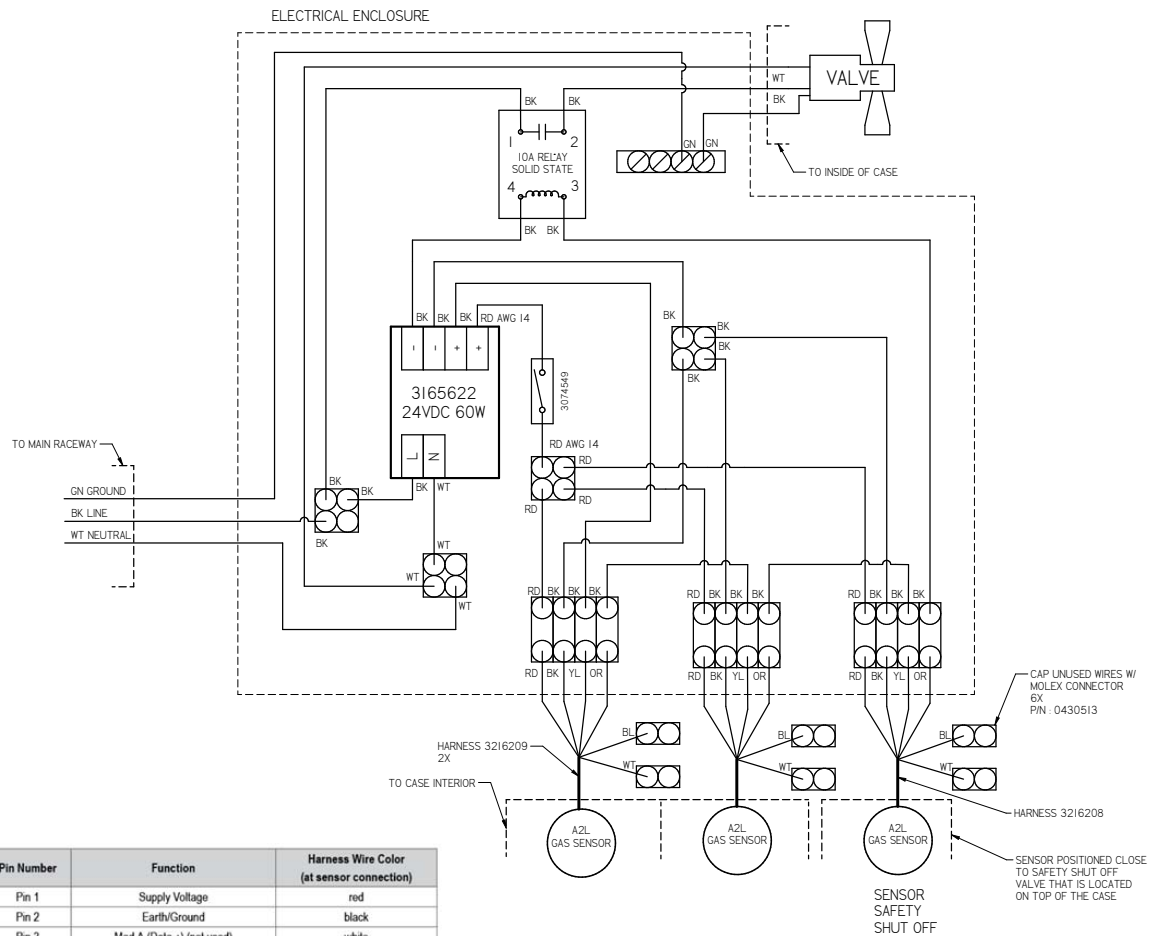

Pin Number	Function	Harness Wire Color (at sensor connection)
Pin 1	Supply Voltage	red
Pin 2	Earth/Ground	black
Pin 3	Mod A (Data +) (not used)	white
Pin 4	Mod B (Data -) (not used)	blue
Pin 5	Input Relay	yellow
Pin 6	Normally Open Contacts Output	orange

**Relay Operation**

- Relay is energized on power up when not in alarm state
- Relay is de-energized in alarm or no power state

<b>WIRE COLOR</b> UL COLOR CODES / ABBREVIATIONS — RED = RD      — WHITE = WT — BLACK = BK    — GREEN = GN — BLUE = BL     — BROWN = BN — YELLOW = YL   — ORANGE = OR — GRAY = GY    — VIOLET = VT	FACTORY I4GA WIRE FACTORY I0GA WIRE FIELD WIRE	<b>HUSSMANN®</b> DIAGRAM-A2L GAS DETECT INSIGHT DANFOSS
	DO NOT SCALE DRAWING SHEET 3 OF 4	

**Wiring Diagram (ID6SU4, A2L detection and mitigation system)**

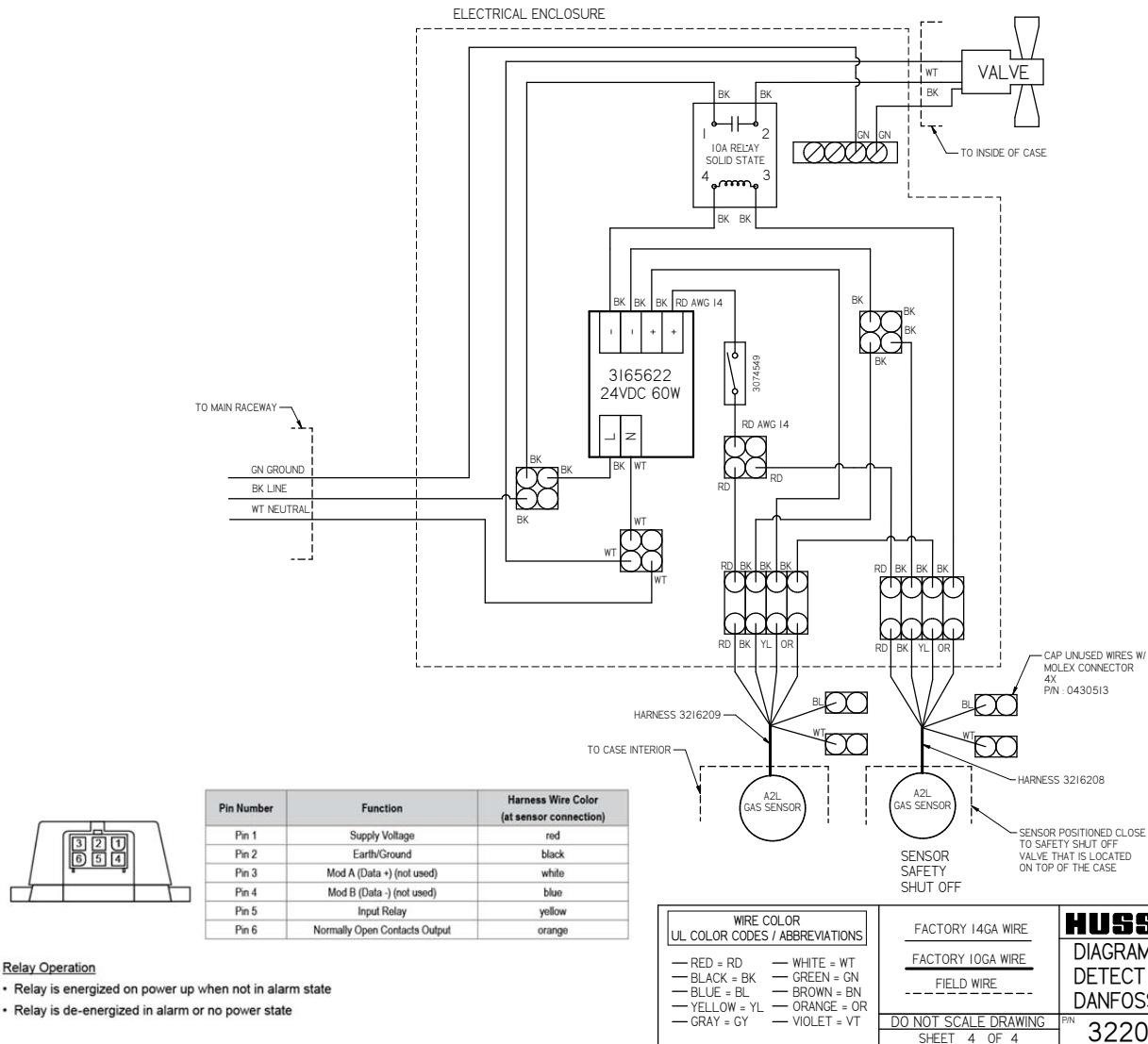

---

## DS\_ID6SU\_0541494\_R\_EN

### Revision History

Revision M: (July 2022) Added notes for Extended Drain Kit Option

Revision N: (January 2023) Added CO<sub>2</sub> note, page 2.

Revision P: (November 2023) Updated fan and lighting information.

Revision Q: (January 2025) Updated format and added A2L, CO<sub>2</sub>, and glycol information.

Revision R: (February 2026) Updated format and added A2L, CO<sub>2</sub>, and glycol information.



Scan the QR code on your mobile device to access additional product information or order parts.

Parts may also be ordered at:  
**parts.hussmann.com**  
Call toll free: **1.855.487.7778**

We reserve the right to change or revise specifications and product design in connection with any feature of our products. Such changes do not entitle the buyer to corresponding changes, improvements, additions or replacements for equipment previously sold or shipped.