

*Coils, fans and TXVs are modular with one per 3 or 4 foot section.

Portion of parts removed for clarity.

8 foot merchandiser shown.

Certifications



Intertek

NSF/Sanitation Compliance

This merchandiser model is manufactured to meet NSF/ANSI Standard 7 requirements for construction, materials, and cleanability.

⚠ WARNING

Component parts shall be replaced with like components, and servicing shall be done by factory authorized service personnel only, so as to minimize the risk of possible ignition due to incorrect parts or improper service.

Technical Datasheet

IM4SL

Open Multideck Medium Temperature Display Case

Applications
Meat

P/N 0541509 Rev L
March 2026

Models Covered
IM4SL4, IM4SL6,
IM4SL8, IM4SL12

Refrigerant(s)
A2L (R-454A or R-454C)
R-744 (CO₂)
HFC/HCFC/HFO

Table of Contents

Model Name	2
Performance Data	3
Refrigerant Data	4
Cross-section View	5
Plan View	6
Electrical Specifications	7
Estimated Shipping Weight	8
Shelf Options	8
Wiring Diagrams	9

We reserve the right to change or revise specifications and product design in connection with any feature of our products. Such changes do not entitle the buyer to corresponding changes, improvements, additions, or replacements for equipment previously sold or shipped.

WARNING:

Read the entire installation, operation, and service manual before installing, servicing, or using this equipment in any way. Refer to the manual for detailed information about minimum room floor area and installation, maintenance, and service processes.

A2L Equipped Models

If the information in the instructions are not followed exactly, a fire or explosion may result, causing property damage, personal injury, or death. Installation and service must be performed by a qualified installer or service agency.



Mildly flammable A2L refrigerant used. Units that are configured to use A2L refrigerants require special attention. No open flames, cigarettes, or other possible sources of ignition should be used inside or in the vicinity of units containing flammable refrigerants.

If a refrigerant leak is present or even suspected, do not allow untrained personnel to attempt to find the cause. No open flames, cigarettes, or other possible sources of ignition should be used inside or in the vicinity of the unit(s). Intrinsically safe components are the only types that can be worked on while live in the presence of a flammable atmosphere.

Information on pre-installed A2L refrigerant sensors and detectors, safety shut-off and check valves, relay information, and additional parts replacement information can be found in the associated installation, operation, and service manual. All manual information must be reviewed in full prior to performing any work.

R-744 (CO₂) Equipped Models

This equipment uses carbon dioxide (R-744 [CO₂]) refrigerant for heat transfer. The system is sealed and pressure-tested with ASME-certified vessels, but leaks can occur in the event of a system failure. A CO₂ leak in an unventilated space can pose serious hazards. Therefore, units must be installed in areas with adequate ventilation and in accordance with local safety codes.

A leak of R-744 could result in a concentration exceeding the practical limit in an enclosed, occupied space such as a cold room. Precautions must be taken to prevent asphyxiation. These include the use of permanent leak detection, which activates an alarm in the event of a leak.



Observe all warnings and labels on the unit being installed or serviced such as the one below indicating high pressure.

All refrigeration servicing must be completed by a certified refrigeration installation professional, and all tubing and components MUST be qualified for CO₂ applications, with a minimum design pressure of 1,305 psig (90 bar).

Failure to abide by all warnings contained within the associated manual could result in an explosion, death, injury, and property damage.

Model Nomenclature

“IM4SL” is followed by a number representing the length of the case in feet (i.e., a 12-foot model would be “IM4SL12”).

Ordering Information

All options must be selected at time of ordering. Some lengths and/or applications require optional fan motor kits applied by the Hussmann Product Configurator (HPC).

Insight IM4SL

Meat

Refrigeration Data ¹

IM4SL		Optimal Shelf Life		Energy Comparison
Application		Meat	NSF Type 2 Ambient ⁴	AHRI 1200 Rating Point ⁵
Unlit Shelves	Discharge Air °F (°C)	32 (0)	32 (0)	35 (1.66)
	Average Evaporator °F (°C) ^{2,3}	28 (-2.22)	27 (-2.77)	32 (0)
	Parallel Btu/hr/ft (Watts/m) ⁶	921 (886)	1005 (966)	779 (749)
	Conventional Btu/hr/ft (Watts/m) ⁶	1005 (966)	1095 (1053)	850 (817)
Lit Shelves	Discharge Air °F (°C)	31 (-0.55)	31 (-0.55)	35 (1.66)
	Average Evaporator °F (°C) ^{2,3}	27 (-2.77)	26 (-3.33)	31 (-0.55)
	Parallel Btu/hr/ft (Watts/m) ^{6,7}	930 (895)	1015 (976)	788 (758)
	Conventional Btu/hr/ft (Watts/m) ^{6,7}	1015 (976)	1105 (1063)	860 (827)
Fan Speed ⁸	IM4SL6 (8.25")	1300	1300	1300
	IM4SL4, 8, 12 (8.25")	1300	1300	1300

Notes:

- All data based on store temperature and humidity that does not exceed NSF Type 1 ambient conditions of 75°F and 55% relative humidity except where noted.
- Average evaporator temperature shown. Use dew point for high glide refrigerants for unit sizing. Care should be taken to use the dew point in PT tables for measuring and adjusting superheat. Adjust evaporator pressure as needed to maintain discharge air temperature shown.
- For DX CO₂ applications the average evaporator temperature may be lowered by 2°F but not more than 5°F. An EPR valve should be used if the system suction temperature is more than 5 degrees below the published case evaporator temperature. A 31°F flash tank temperature with a 24°F evaporator temperature is used when sizing default EEV selections to provide a minimum pressure drop across the valve of approximately 50 psig. For operating conditions that provide a pressure drop across the valve above 65 psig or below 35 psig, the electronic expansion valve size should be determined using the valve vendor sizing program and selected from the pull down list in the Hussmann Product Configurator (HPC).
- Data for operation in NSF Type 2 ambient of 80°F and 55% relative humidity.
- AHRI 1200 Rating Point for energy consumption comparison only.
- Subtract 120 Btu/hr/ft (115.4 Watts/m) for front glass (on applicable models).
- Add 10 Btu/hr/ft (9.6 Watts/m) per shelf row for LED shelf light fixtures.
- Some lengths and/or applications require optional fan motor kits applied by the Hussmann Product Configurator (HPC).

Defrost Data

Frequency (hours between defrost) 4
Defrost Water ⁹ 7.5 lb/ft/day
 (11.2 kg/m)
⁹ (± 15% based on case configuration and product loading).

OFFTIME **IM4SL**
Time (minutes) 20

ELECTRIC OR GAS Not Available

Conventional Controls

IM4SL
Low Pressure Backup Control CI/CO ¹⁰
 20°F / 10°F
 -6.7°C / -12.2°C

Indoor Unit Only, Pressure Defrost Termination ¹⁰
 48°F (8.9°C)

¹⁰ Use a Temperature Pressure Chart to determine PSIG conversions.

Product Data

Gross Refrigerated Volume ¹² (Cu Ft/Ft) 7.7 ft³ /ft (0.72 m³/m)
AHRI Total Display Area ¹³ (Sq Ft/Ft) 3.36 ft² /ft (1.02 m²/m)
Shelf Area ¹⁴ (Sq Ft/Ft) 6.51 ft² /ft (1.98 m²/m)

¹² AHRI Gross Refrigerated Volume: Refrigerated Volume/Unit of Length, ft³/ft [m³/m]

¹³ Computed using AHRI 1200 standard methodology: Total Display Area, ft² [m²]/Unit of Length, ft [m]

¹⁴ Shelf surface area is composed of bottom deck plus standard shelf complement for this model: (3) rows of shelves: 14-in., 16-in., 18-in.

Refrigerant Data

Approximate HFC/HCFC/HFO Refrigerant Charge¹⁵

Case	Estimated Charge
IM4SL4	9.6 oz (272 g)
IM4SL6	17.6 oz (499 g)
IM4SL8	24 oz (680 g)
IM4SL12	46.4 oz (1,315 g)

A2L Refrigerant Charge

Model	Minimum Room Floor Area ft ² (m ²)	Estimated Refrigerant Charge — lb (g)	
		Operating Charge	
		R-454A	R-454C
IM4SL4	106 (9.8)	1.5 (565)	1.5 (565)
IM4SL6	106 (9.8)	2 (901)	2 (901)
IM4SL8	196 (18.2)	2.5 (1,142)	2.5 (1,142)
IM4SL12	196 (18.2)	3.7 (1,684)	3.7 (1,684)

R-744 (CO₂) Pressure Rating

Case Configuration	Pressure Rating
standard pressure CO ₂	652 psi (45 bar)
high pressure CO ₂	1,305 psi (90 bar)

Glycol Heat Transfer Fluid Data (Meat)

Model	Conventional Load BTU/h/ft (W/m)	Discharge Air Temperature ° F (° C)	Coil Inlet Temperature ° F (° C)	Coil Temp. Rise ° F (° C)	Average Coil Temperature ° F (° C)	Flow Rate GPM (LPM)	Pressure Drop PSI (bar)
IM4SL4	1,015 (974)	31 (-0.6)	25 (-3.9)	4 (2.2)	27 (-2.8)	2.2 (8.3)	6.2 (0.4)
			20 (-6.7)	14 (7.8)	27 (-2.8)	0.6 (2.3)	1.4 (0.1)
IM4SL6	1,015 (974)	31 (-0.6)	25 (-3.9)	4 (2.2)	27 (-2.8)	3.3 (12.5)	4.4 (0.3)
			20 (-6.7)	14 (7.8)	27 (-2.8)	1.0 (3.8)	0.9 (0.1)
IM4SL8	1,015 (974)	31 (-0.6)	25 (-3.9)	4 (2.2)	27 (-2.8)	4.5 (17.0)	7.3 (0.5)
			20 (-6.7)	14 (7.8)	27 (-2.8)	1.3 (4.9)	1.7 (0.1)
IM4SL12	1,015 (974)	31 (-0.6)	25 (-3.9)	4 (2.2)	27 (-2.8)	6.6 (25.0)	7.5 (0.5)
			20 (-6.7)	14 (7.8)	27 (-2.8)	2.0 (7.6)	2.0 (0.1)

¹⁵ This is an average for all refrigerant types. Actual refrigerant charge may vary by approximately half a pound.

Insight Multideck Merchandiser,
4 Display Levels, Standard Bottom,
Low Height Front



Husmann refrigerated merchandisers configured for sale for use in the United States meet or surpass the requirements of the DOE 2017 energy efficiency standards.

Other optional kits (top piping and vent fans) add to the overall case height.

A minimum 1 1/2-in. clearance required to remove raceway cover, 6 1/2-in. for full access. See the Installation manual for instructions.

3-in. between back to back cases.

Shelf complement shown as tested:

Three rows of shelves (14-in., 16-in., 18-in.), spaced equally between bottom display pan and interior top panel, all down-tilted at 10° with a 12-in. mirror installed in the top, rear corner of the case.

Shown with Ellipse Option Canopy and Bumper.

OPTIONAL RAIL LIGHT

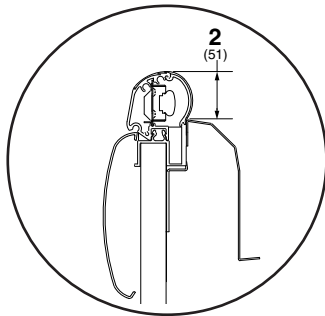

Rail light cannot be used with glass front option.

OPTIONAL GLASS FRONT

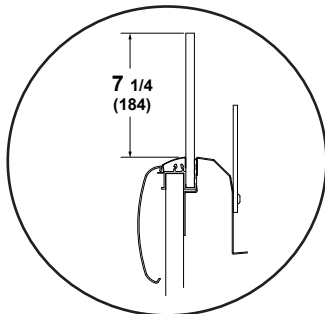

Glass front cannot be used with rail light option.

Dimensions shown as in. and (mm).

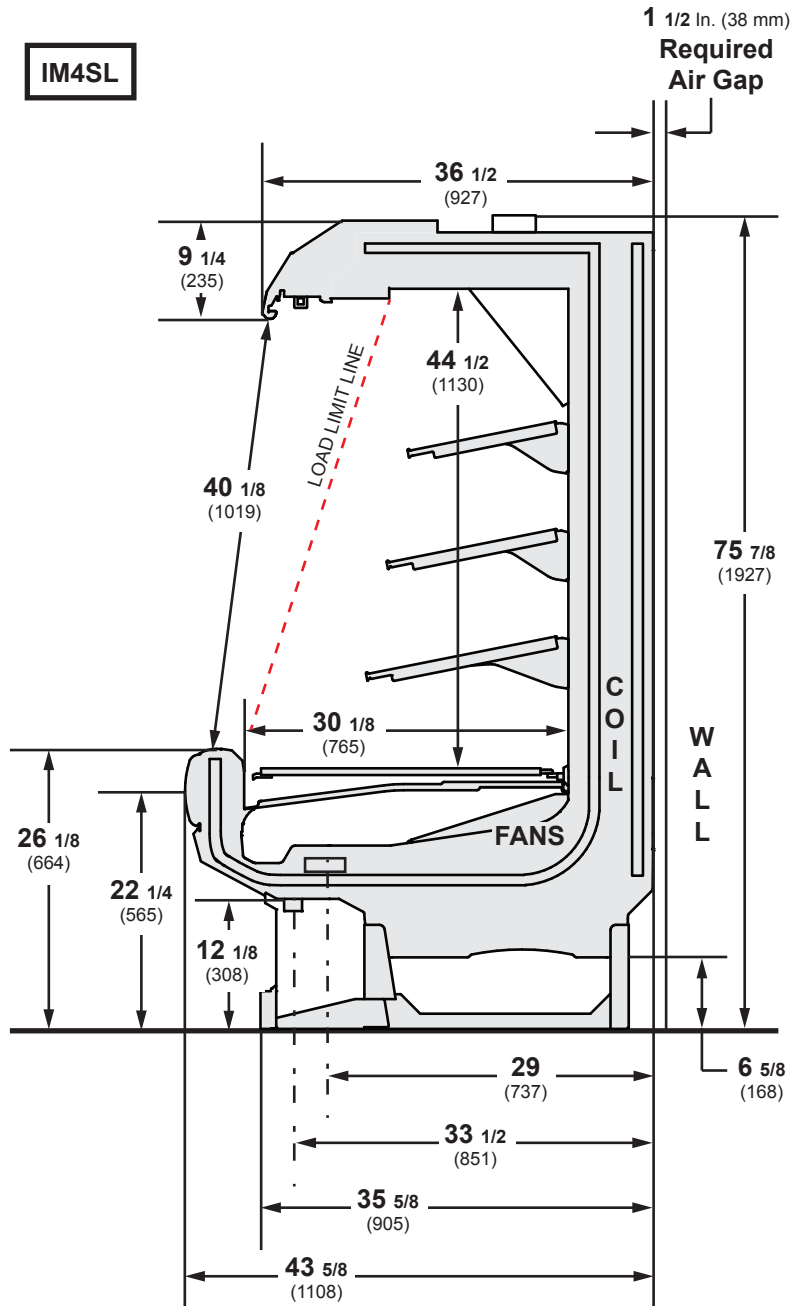

NSF Certification

This merchandiser model is manufactured to meet NSF/ANSI (National Sanitation Foundation) Standard #7 requirements for construction, materials and cleanability.

Engineering Plan View

**IM3SL/IM4SL/
IM5SL/IP2SL/
IP4SL**

Dimensions shown as in. and (mm).

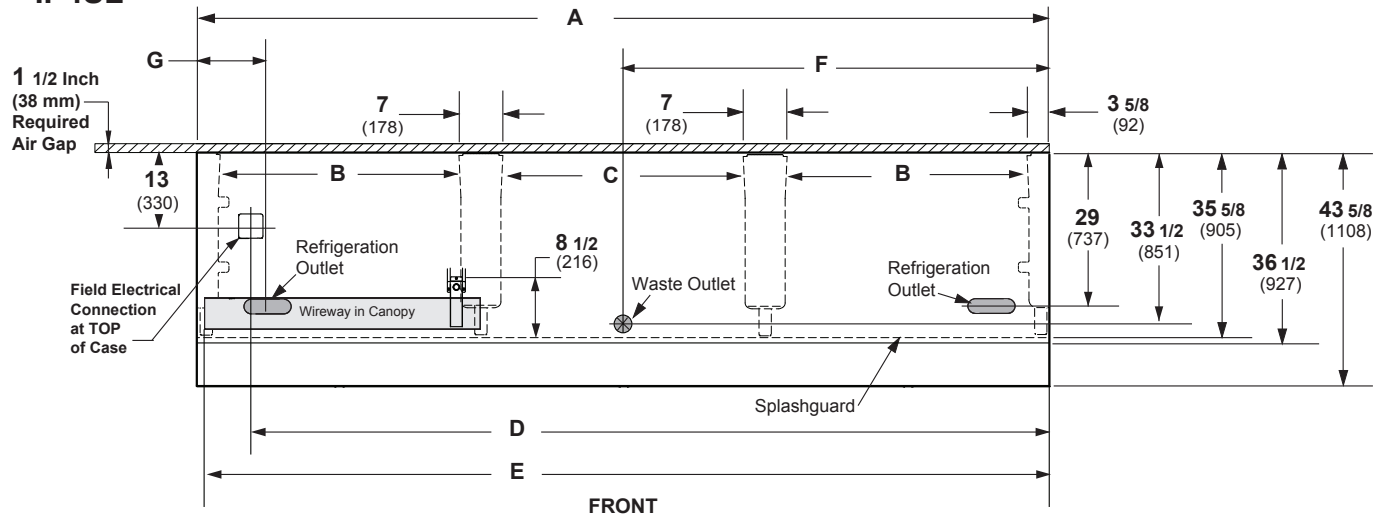

	4 ft	6 ft	8 ft	12 ft
General				
(A) Case Length (without ends or partitions) (Each end and insulated partition adds 1 1/2 in. (38 mm) to case line up.)	48 1/8 (1222)	72 1/4 (1835)	96 1/4 (2445)	144 3/8 (3668)
Maximum O/S dimension of case back to front (includes bumper)	43 5/8 (1108)	43 5/8 (1108)	43 5/8 (1108)	43 5/8 (1108)
Back of case to front of splashguard	35 5/8 (905)	35 5/8 (905)	35 5/8 (905)	35 5/8 (905)
(B) Distance between edges of external legs and center legs	NA	29 (737)	41 (1041)	41 (1041)
(C) Distance between edges of center legs	41 1/8 (1045)	NA	NA	41 1/8 (1045)
Distance between front legs and splashguard	8 (203)	8 (203)	8 (203)	8 (203)
Electrical Service (Field Electrical Wiring Connection)				
(D) RH End of case to center of Field Electrical Wiring Connection (top of case)	39 3/8 (1000)	63 1/2 (1613)	87 1/2 (2223)	135 1/2 (3442)
Back of case to center of Field Electrical Wiring Connection	13 (330)	13 (330)	13 (330)	13 (330)
Length of electrical wireway	44 5/8 (1133)	33 1/2 (851)	45 7/8 (1191)	45 7/8 (1191)
(E) RH end of case to LH end of electrical wireway (top of case)	46 1/2 (1181)	70 1/2 (1791)	94 1/2 (2400)	142 5/8 (3623)
Waste Outlets				
(F) RH End of case to the center of waste outlet	24 1/8 (613)	24 1/8 (613)	24 1/8 (613)	72 1/4 (1835)
Back O/S of case to center of waste outlet(s)	33 1/2 (851)	33 1/2 (851)	33 1/2 (851)	33 1/2 (851)
Schedule 40 PVC drip pipe	1 1/4 (32)	1 1/4 (32)	1 1/4 (32)	1 1/4 (32)
Refrigeration Outlet				
(G) Back of case to center of refrigeration outlet	29 (737)	29 (737)	29 (737)	29 (737)
End of case to center of refrigeration outlet	8 1/2 (216)	8 1/2 (216)	8 1/2 (216)	8 1/2 (216)

Electrical Data

Number of Fans	4 ft	6 ft	8 ft	12 ft
8.25-in.	1	2	2	3

Evaporator Fan	Amperes				Watts			
	4 ft	6 ft	8 ft	12 ft	4 ft	6 ft	8 ft	12 ft
120V 60Hz Energy Efficient	0.25	0.50	0.50	0.75	16	32	32	48
230V 50/60Hz Energy Efficient	0.13	0.26	0.26	0.39	16	32	32	48

Minimum Circuit Ampacity

120V 60Hz Energy Efficient	0.45	0.70	0.70	0.95
230V 50/60Hz Energy Efficient	0.33	0.46	0.46	0.59

Maximum Over Current Protection

120V	20	20	20	20
230V	15	15	15	15

Lighting

ONLY LIGHTING CONFIGURATIONS THAT ARE COMPLIANT WITH THE U.S. DEPT. OF ENERGY (DOE) 2017 REGULATION ARE AVAILABLE FOR SALE FOR USE IN THE U.S.A.

	Amperes				Watts			
	4 ft	6 ft	8 ft	12 ft	4 ft	6 ft	8 ft	12 ft
LED LIGHTING								
Standard LED Canopy Lights								
1 Row LED Canopy (Standard)	0.16	0.22	0.31	0.47	19	27	38	57
Optional LED Shelf Lights								
1 Row of Shelves	0.06	0.07	0.11	0.17	7	9	13	20
2 Rows of Shelves	0.11	0.15	0.22	0.33	13	18	27	40
3 Rows of Shelves	0.17	0.22	0.33	0.50	20	27	40	60
4 Rows of Shelves	0.22	0.30	0.44	0.67	27	36	53	80
5 Rows of Shelves	0.28	0.37	0.56	0.83	33	44	67	100
Rail Light-1 Row	0.06	0.07	0.11	0.17	7	9	13	20

120V Lighting Circuit Total = Standard Lighting + Total Optional Lighting + Optional Shelf Lighting

230V Lighting Circuit Total = Multiply 120V Lighting Circuit Total by 0.52

Insight IM4SL
Meat

ENDS or PARTITIONS

Each standard end and each insulated partition adds 1 1/2 in. (38 mm) to case line up. Optional view end with end bumper adds 3 3/4 in. (95 mm).

PHYSICAL DATA

Merchandiser Drip Pipe (in.)	1 1/4
Schedule 40 PVC	
Merchandiser Liquid Line (in.)	3/8
Merchandiser Suction Line (in.)	5/8

ESTIMATED SHIPPING WEIGHT †

Case	ESTIMATED SHIPPING WEIGHT †					Solid End (each)
	4 ft	6 ft	8 ft	12 ft		
lb (kg)	600 (272)	800 (363)	950 (431)	1200 (544)		75 (34)

† Actual weights will vary according to optional kits included.

Shelf Options

Approved shelf sizes for standard (horizontal, 2-3 position brackets) displays:

- 14-inch
- 16-inch
- 18-inch
- 20-inch
- 22-inch

Contact engineering for non-standard (4 position brackets or other) display recommendations.

Minimum number of Shelves: 2

Optimal number of Shelves: 3

Maximum number of Shelves: 5

Maximum number of Lighted Shelves: 4

Standard shelf complement for test purposes: (3) rows of shelves (14-in., 16-in., 18-in.), evenly distributed vertically, all down-tilted at 10° with a 12-in. mirror installed in the top, rear corner of the case.

Fan Wiring Offtime Defrost

Insight **IM4SL**
Meat

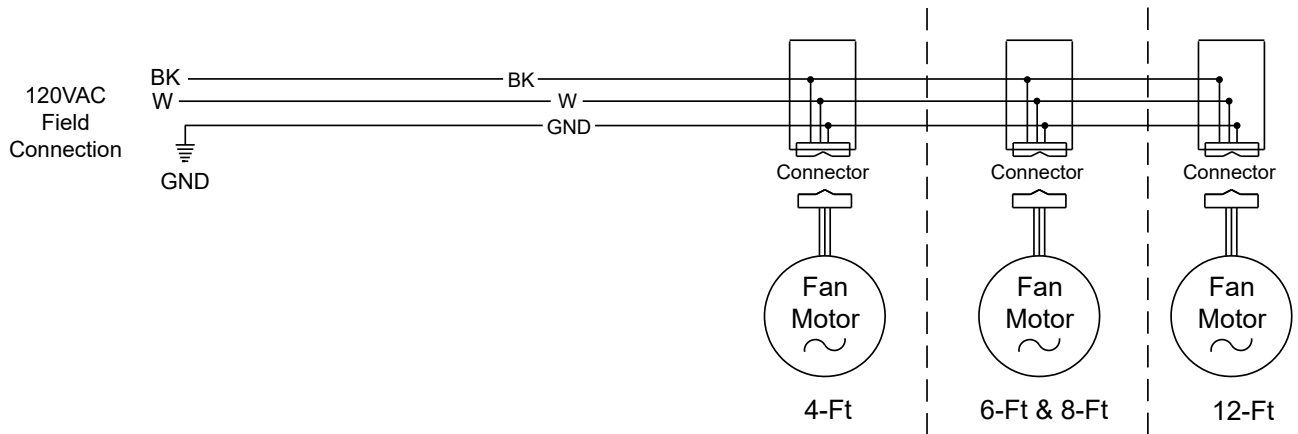

LED Canopy Light Circuits

LED Canopy Lighting - 1 Row

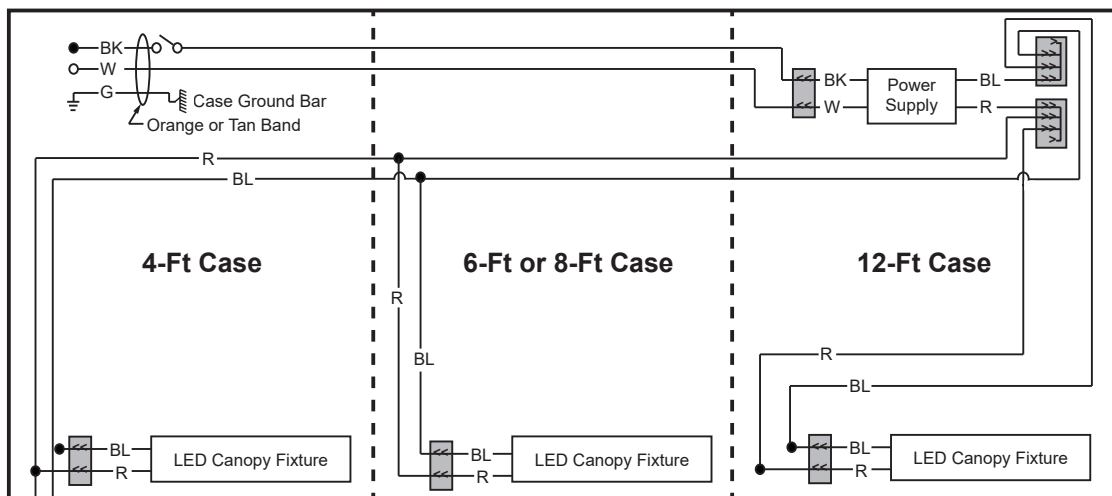

Optional Lighting - LED Rail - 1 Row

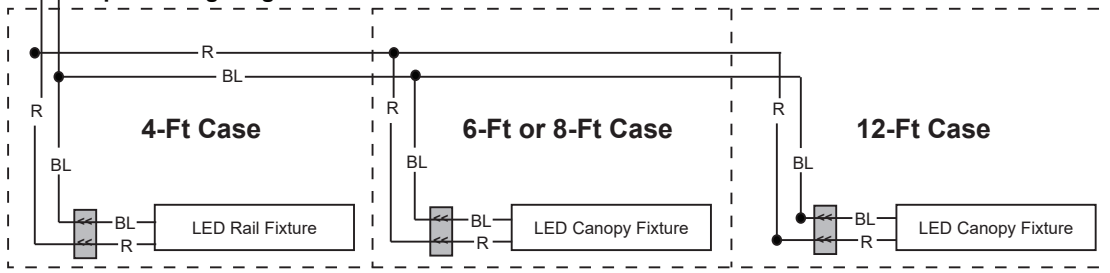

WARNING

All components must have mechanical ground, and the merchandiser must be grounded.

R = Red Y = Yellow G = Green BL = Blue BK = Black W = White
 ● = 120V POWER ○ = 120V NEUTRAL ⊥ = FIELD GROUND = CASE GROUND

Optional LED Shelf Lighting

Optional Shelf Harness and LED Light Circuits for 2 or 3 Rows of Shelves

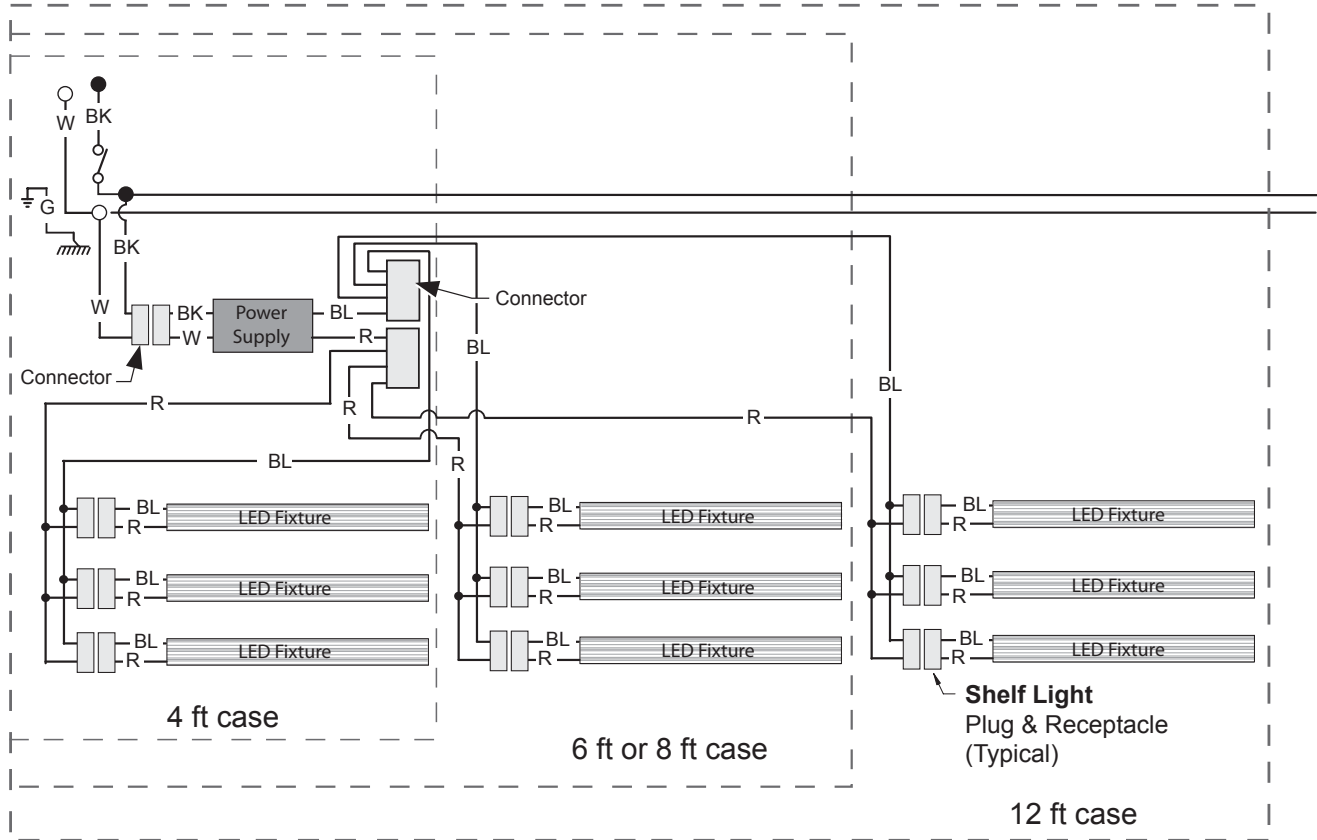

WARNING

All components must have mechanical ground, and the merchandiser must be grounded.

R = Red Y = Yellow G = Green BL = Blue BK = Black W = White
 ● = 120V POWER ○ = 120V NEUTRAL ⚡ = FIELD GROUND ⏏ = CASE GROUND

Optional Shelf Harness and LED Light Circuits for 4 Rows of Shelves

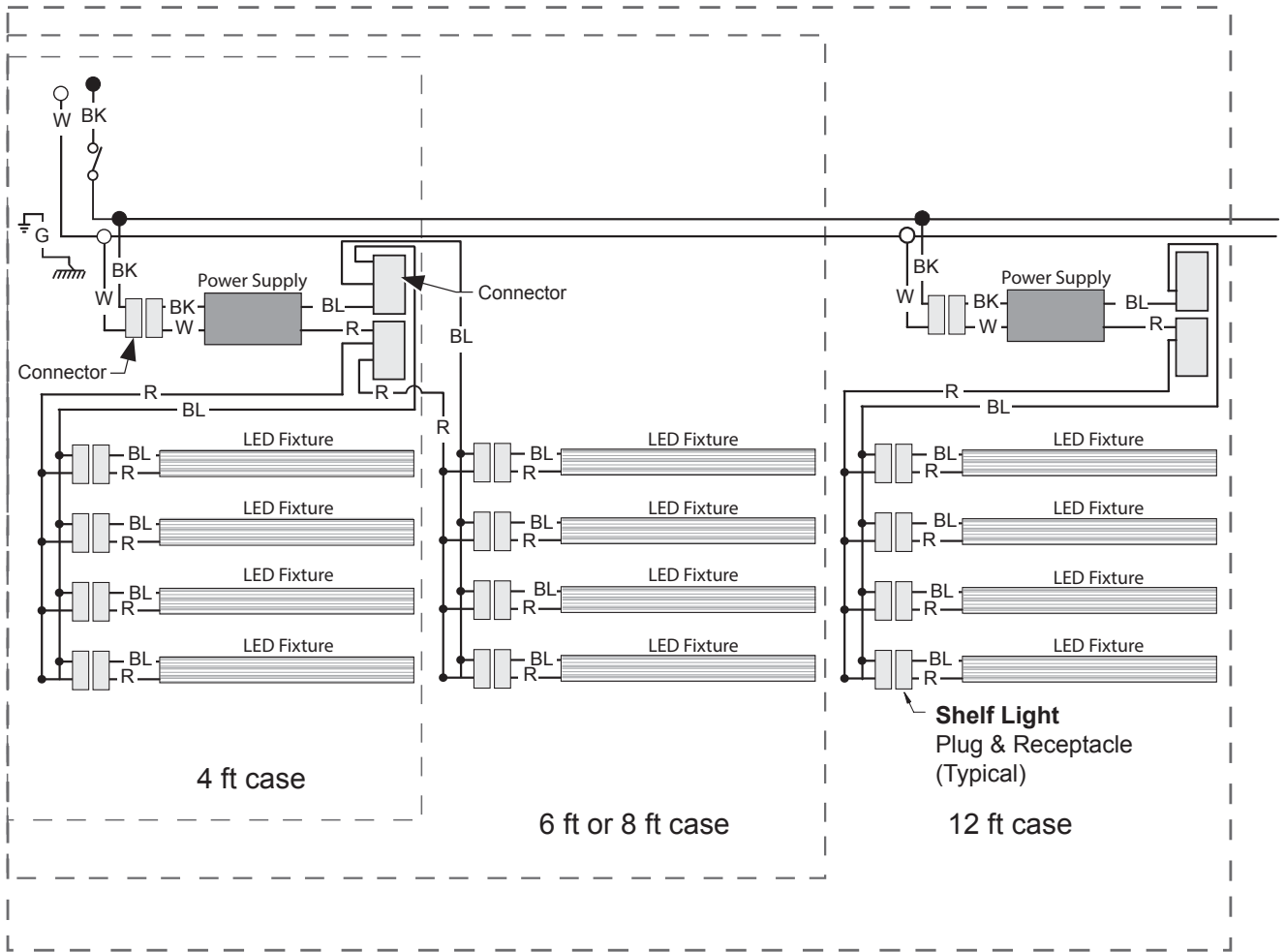

WARNING

All components must have mechanical ground, and the merchandiser must be grounded.

R = Red Y = Yellow G = Green BL = Blue BK = Black W = White
 ● = 120V POWER ○ = 120V NEUTRAL ⊥ = FIELD GROUND ≡ = CASE GROUND

Wiring Diagram (A2L detection and mitigation system)

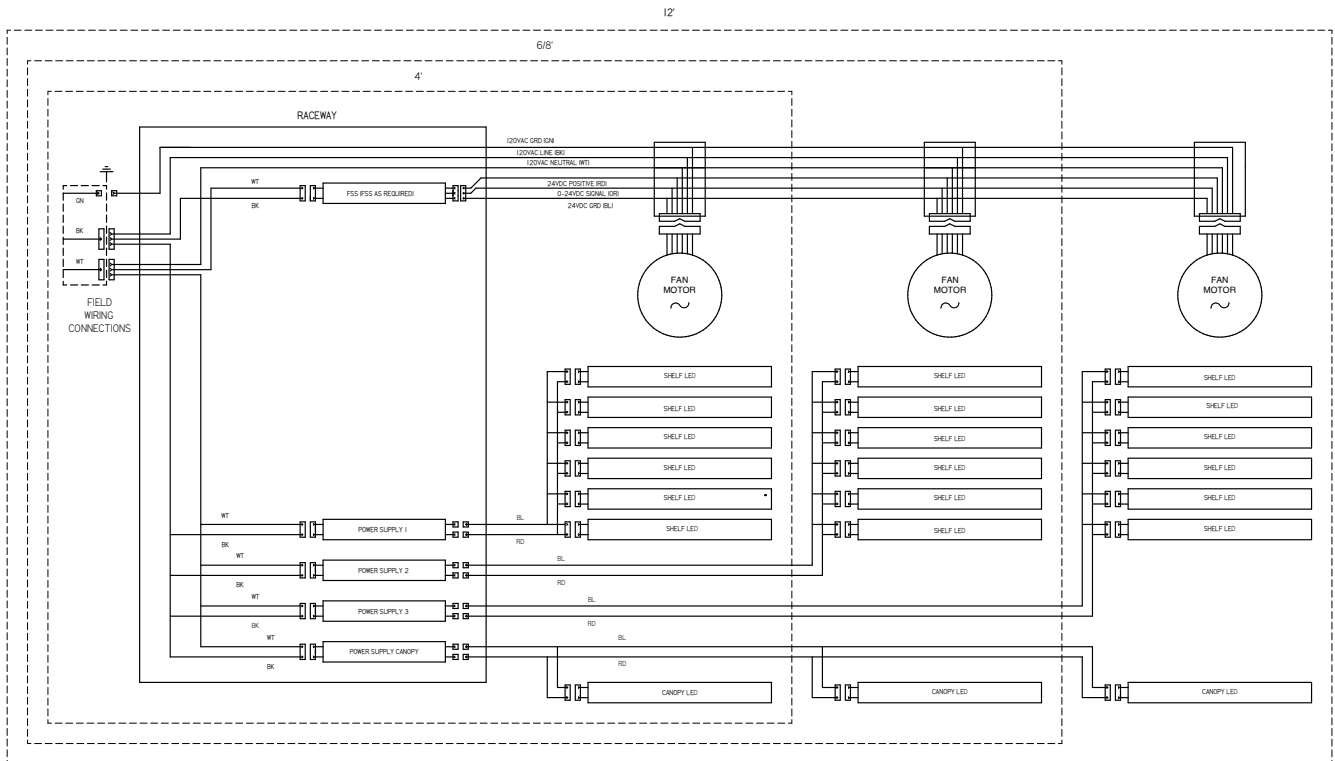

<p>WIRE COLOR UL COLOR CODES / ABBREVIATIONS</p> <p>— RED = RD — WHITE = WT — BLACK = BK — GREEN = GN — BLUE = BL — BROWN = BN — YELLOW = YL — ORANGE = OR — GRAY = GY — VIOLET = VT</p>	<p>FACTORY 14GA WIRE</p> <p>FACTORY 10GA WIRE</p> <p>--- FIELD WIRE ---</p>	<p>HUSSMANN® DIAGRAM-A2L GAS DETECT INSIGHT DANFOSS</p>
	<p>DO NOT SCALE DRAWING</p> <p>SHEET 1 OF 4</p>	

GP-33 WIRE DIAGRAM-ISE-D-11

Wiring Diagram (IM4SL12, A2L detection and mitigation system)

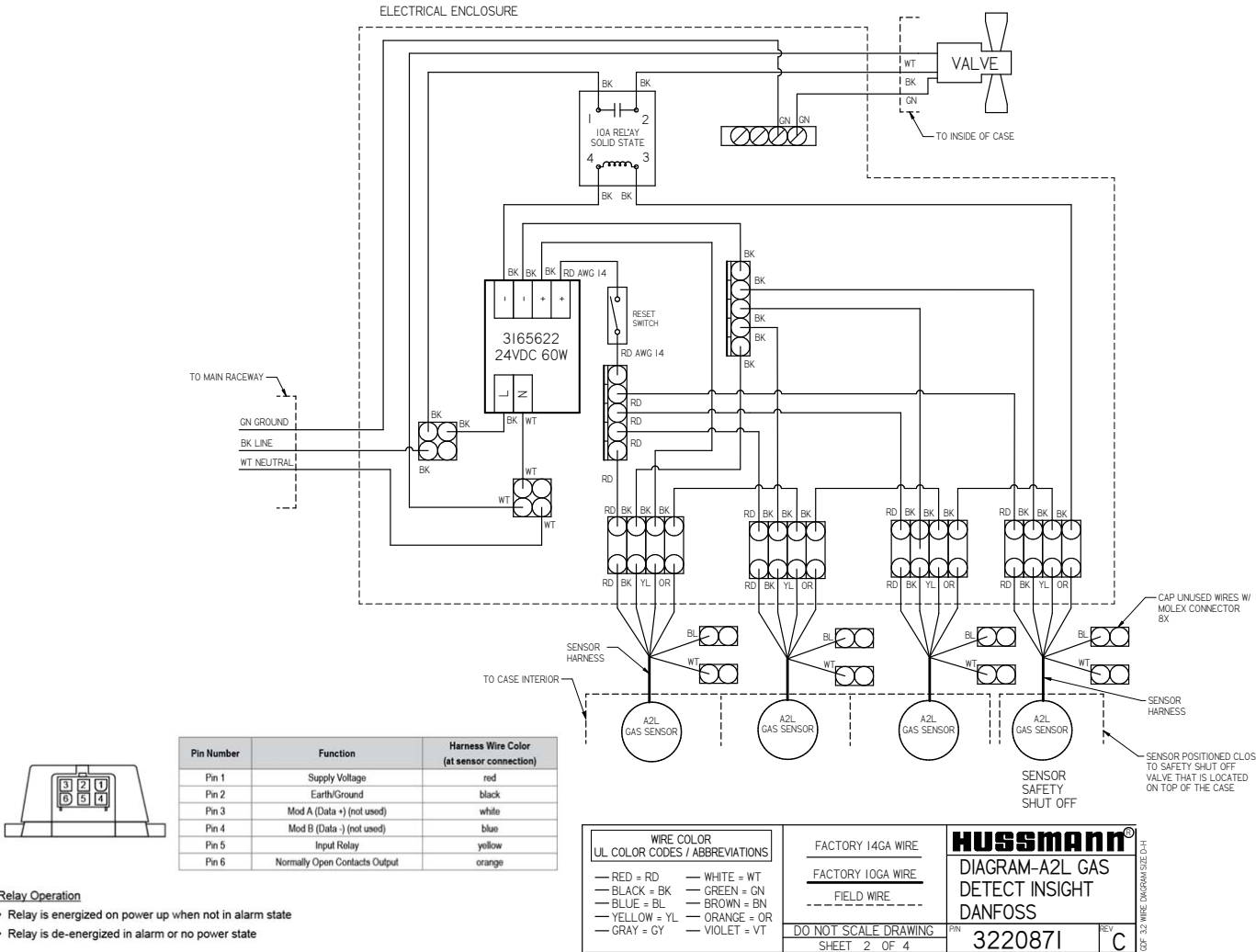

Wiring Diagram (IM4SL4, A2L detection and mitigation system)

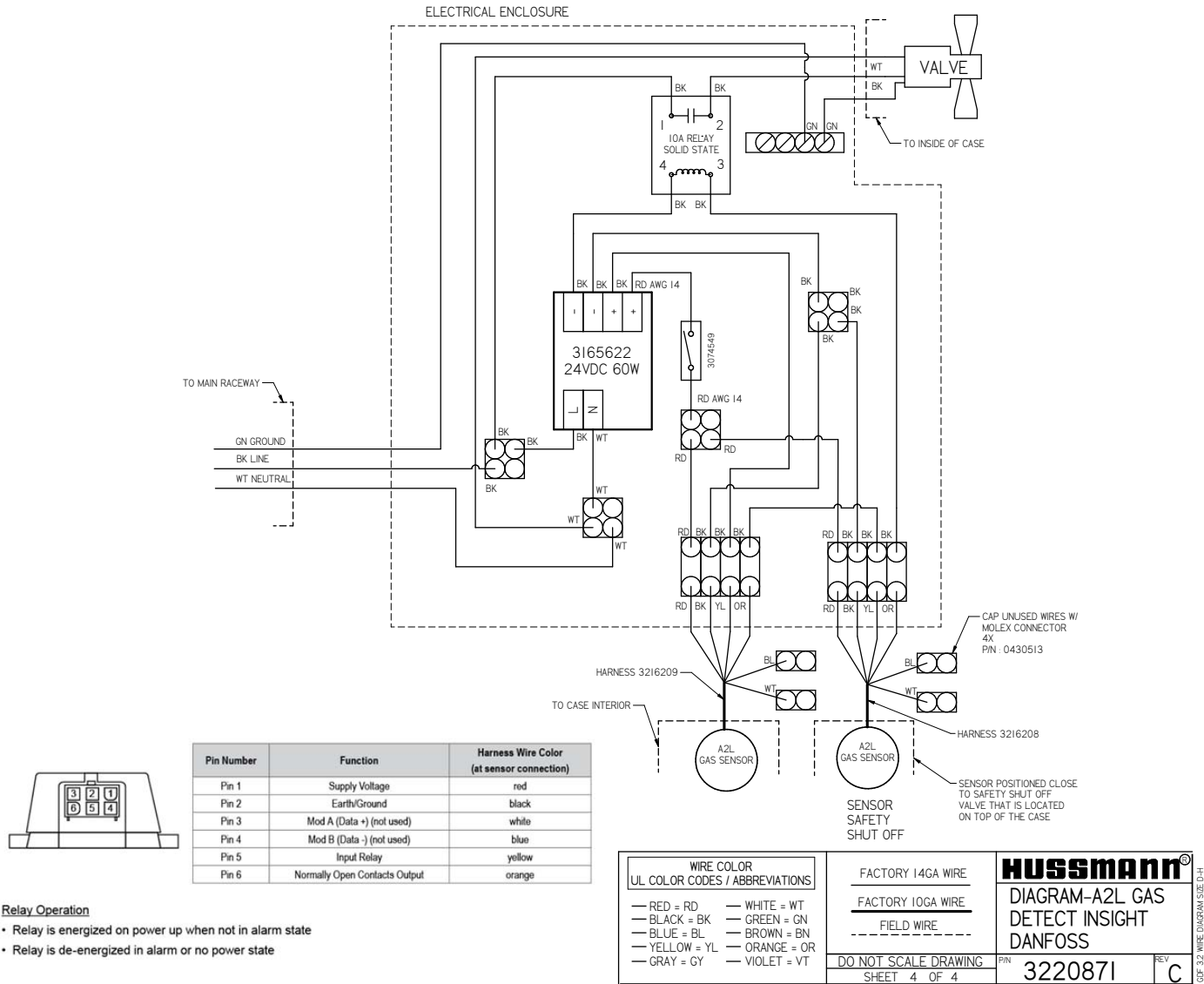

Relay Operation

- Relay is energized on power up when not in alarm state
- Relay is de-energized in alarm or no power state

Estimating Refrigeration and Electrical Load (for comparison purposes only)

Case Btu

To determine Btu for a case, refer to the performance data chart on page 2. Select lit or unlit shelves, then select the type of remote refrigeration system (parallel or conventional), which will give Btu/hr/ft. Multiply this number by the length of the case to determine Btu per hour.

Case Electrical

Refer to store legend to determine number of circuits. Lighting should be specified in store legend.

Fan electrical load for a case is computed by selecting the case length and fan voltage on page 6. For example, a 12 ft case uses 3 fans. The store legend specifies fans on a 230V circuit. In this instance, fans use 0.39 Amps and the MCA is 0.59. When applied, ambient fans, anti-sweat heaters, controllers, etc. must be included in the MCA. Include lights in the MCA if lights are on same circuit.

Lights may be on a separate circuit. To estimate lighting load: select case length (12 ft), canopy lighting [standard or optional] (here 0.70 for standard), and shelf or rail lighting [maximum for which case is wired] (0.99 for four shelves); then add together $[0.48 + 0.99 = 1.47 \text{ amps for } 120\text{V}]$ (for 230V, multiply $1.47 * 0.52 = 0.76$).

Line Sizing — Refer to store legend.

Hussmann Line Sizing Charts are engineered for use with Hussmann refrigeration equipment.



Scan the QR code with your mobile device to access additional product information or order parts.

Parts may also be ordered at:

parts.hussmann.com

Call toll free: 1.855.487.7778

Revision History

Revision A: May 2014: Original Issue

Revision B: December 2015: Updated cross section and plan view.

Revision C: April 2016: Updated cover image, updated application data, added Gross Refrigerated Volume, added optional glass front kit and updated plan view.

Revision D: August 2016: Updated cross section and plan view.

Revision E: January 2017: Added rail light updates.

Revision F: April 2017: Updated LED energy values.

Revision G: April 2017: Updated LED energy values.

Revision H: September 2017: Updated notes page. Other changes marked with a bar, circle or underline.

Revision J: January 2023: Added CO₂ note, Page 2.

Revision K: December 2023: Updated fan and lighting information. Removed replacement parts page. Updated wiring diagrams.

Revision L: (March 2026) added A2L, CO₂ information