

Insight standard field electrical connections are at the top left of the merchandiser

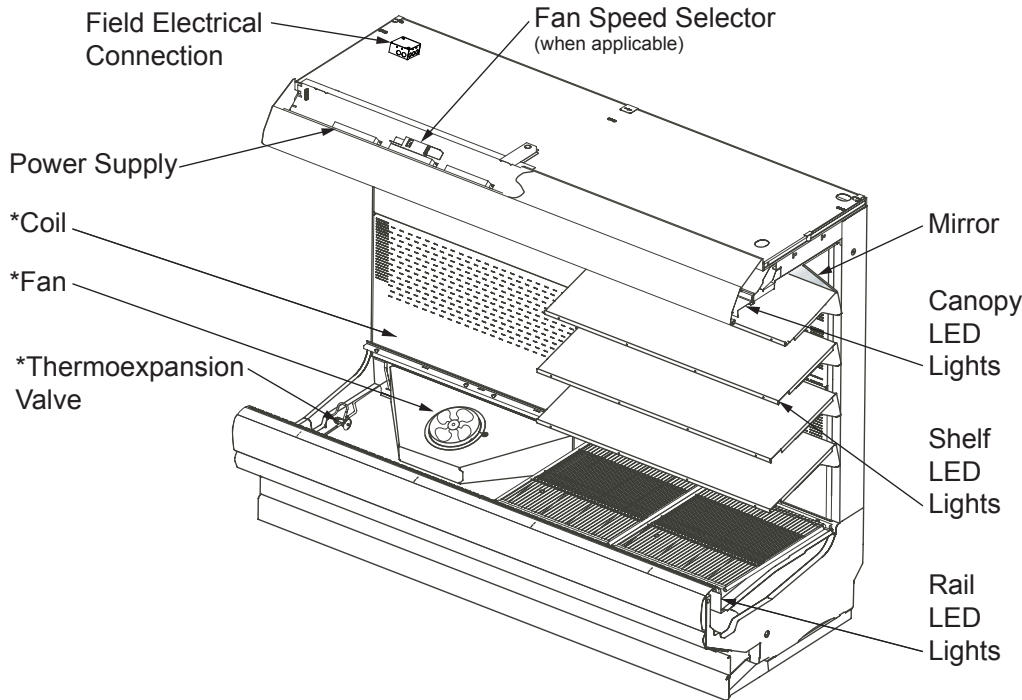

*Coils, fans and TXVs are modular with one per 3 or 4 foot section.

Portion of parts removed for clarity.

8 foot merchandiser shown.

NSF Certification

This merchandiser model is manufactured to meet NSF/ANSI (National Sanitation Foundation) Standard #7 requirements for construction, materials and cleanability.

Performance Data	Page 2	Estimated Shipping Weights	Page 6
Product Data (AHRI Statistics)	Page 2	Shelf Options	Page 6
Cross Section	Page 3	Wiring Diagrams	Page 7
Plan View	Page 4	QR Code for Parts and Product Information	Page 10
Electrical Loads	Page 5	Revision History	Page 10

Data sheet-Insight IM5SL

We reserve the right to change or revise specifications and product design in connection with any feature of our products. Such changes do not entitle the buyer to corresponding changes, improvements, additions or replacements for equipment previously sold or shipped.

Insight IM5SL

Meat & Delicatessen

Refrigeration Data ¹

IM5SL		Optimal Shelf Life		Energy Comparison
Application		Meat	NSF Type 2 Ambient ⁴	AHRI 1200 Rating Point ⁵
Unlit Shelves	Discharge Air °F (°C)	32 (0)	31 (-0.55)	33 (0.55)
	Average Evaporator °F (°C) ^{2,3}	28 (-2.22)	27 (-2.77)	29 (-1.66)
	Parallel Btu/hr/ft (Watts/m) ⁶	1030 (990)	1345 (1294)	965 (928)
	Conventional Btu/hr/ft (Watts/m) ⁶	1125 (1082)	1470 (1414)	1055 (1014)
Lit Shelves	Discharge Air °F (°C)	31 (-0.55)	30 (-1.11)	32 (0)
	Average Evaporator °F (°C) ^{2,3}	27 (-2.77)	26 (-3.33)	28 (-2.22)
	Parallel Btu/hr/ft (Watts/m) ^{6,7}	1045 (1005)	1365 (1313)	980 (942)
	Conventional Btu/hr/ft (Watts/m) ^{6,7}	1140 (1096)	1490 (1433)	1070 (1029)
Fan Speed ⁸	IM5SL6 (8.25")	1400 ⁸	1600 ⁸	1400 ⁸
	IM5SL4, 8, 12 (10.3")	1050	1300 ⁸	1050

Notes:

- All data based on store temperature and humidity that does not exceed NSF Type 1 ambient conditions of 75°F and 55% relative humidity except where noted.
- Average evaporator temperature shown. Use dew point for high glide refrigerants for unit sizing. Care should be taken to use the dew point in PT tables for measuring and adjusting superheat. Adjust evaporator pressure as needed to maintain discharge air temperature shown.
- For DX CO₂ applications the average evaporator temperature may be lowered by 2°F but not more than 5°F. An EPR valve should be used if the system suction temperature is more than 5 degrees below the published case evaporator temperature. A 31°F flash tank temperature with a 24°F evaporator temperature is used when sizing default EEV selections to provide a minimum pressure drop across the valve of approximately 50 psig. For operating conditions that provide a pressure drop across the valve above 65 psig or below 35 psig, the electronic expansion valve size should be determined using the valve vendor sizing program and selected from the pull down list in the Hussmann Product Configurator (HPC).
- Data for operation in NSF Type 2 ambient of 80°F and 55% relative humidity.
- AHRI 1200 Rating Point for energy consumption comparison only.
- Subtract 120 Btu/hr/ft (115.4 Watts/m) for front glass (on applicable models).
- Add 10 Btu/hr/ft (9.6 Watts/m) per shelf row for LED shelf light fixtures.
- Some lengths and/or applications require optional fan motor kits applied by the Hussmann Product Configurator (HPC).

Defrost Data

OFFTIME	IM5SL
Time (minutes)	20
ELECTRIC OR GAS	Not Available
Frequency (hours between defrost)	4
Defrost Water (lb/ft/day) ⁹	7.8 lb/ft/day (11.6 kg/m)
⁹ (± 15% based on case configuration and product loading).	

Conventional Controls

	IM5SL
Low Pressure Backup Control CI/CO ¹⁰	20°F / 10°F -6.67°C / -12.2°C
Indoor Unit Only, Pressure Defrost Termination ¹⁰	48°F (8.89°C)
¹⁰ Use a Temperature Pressure Chart to determine PSIG conversions.	

Estimated Charge ¹¹

	IM5SL	
4 ft	0.6 lb	10 oz
6 ft	1.1 lb	18 oz
8 ft	1.5 lb	24 oz
12 ft	2.9 lb	46 oz

¹¹ This is an average for all refrigerant types. Actual refrigerant charge may vary by approximately half a pound.

Product Data

Gross Refrigerated Volume ¹² (Cu Ft/Ft)	8.9 ft ³ /ft (0.83 m ³ /m)
AHRI Total Display Area ¹³ (Sq Ft/Ft)	3.97 ft ² /ft (1.21 m ² /m)
Shelf Area ¹⁴ (Sq Ft/Ft)	8.35 ft ² /ft (2.54 m ² /m)

¹² AHRI Gross Refrigerated Volume: Refrigerated Volume/Unit of Length, ft³/ft [m³/m]

¹³ Computed using AHRI 1200 standard methodology: Total Display Area, ft² [m²]/Unit of Length, ft [m]

¹⁴ Shelf surface area is composed of bottom deck plus standard shelf complement for this model: (4) rows of shelves: 14-in., 16-in., 18-in., 18-in.

Insight Multideck Merchandiser, 5 Display Levels,
Standard Bottom, Low Height Front



Husmann refrigerated merchandisers configured for sale for use in the United States meet or surpass the requirements of the DOE 2017 energy efficiency standards.

There is a minimum of 1.5-in. clearance required to remove the raceway cover, 6.5 ft for full access. See Installation manual for instructions.

3-in. between back to back cases.

Shelf complement shown as tested:

Four rows of shelves (14-in., 16-in., 18-in., 18-in.), spacing between each row of shelves is 9-in., all down-tilted at 15° with a 12-in. mirror installed in the top, rear corner of the case.

Other optional kits (for example, top piping and vent fans) add to the overall case height.

Shown with Ellipse Option Canopy and Bumper.

OPTIONAL RAIL LIGHT

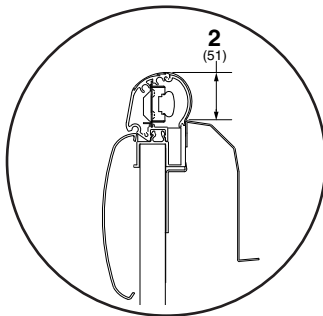

Rail light cannot be used with glass front option.

OPTIONAL GLASS FRONT

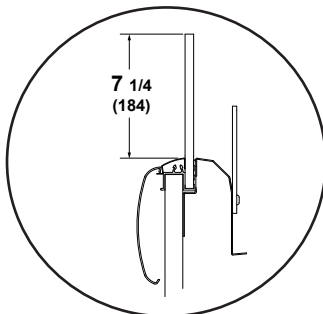

Glass front cannot be used with rail light option.

Dimensions shown as in. and (mm).

IM5SL

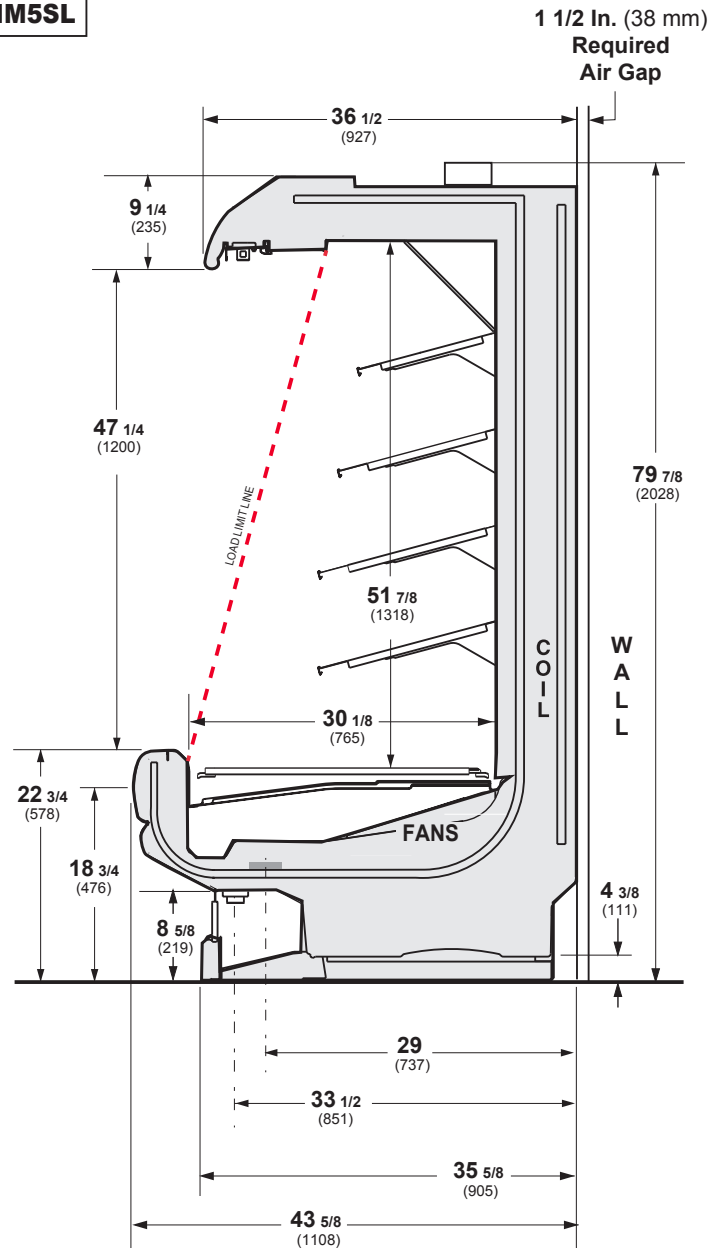

NSF Certification

This merchandiser model is manufactured to meet NSF/ANSI (National Sanitation Foundation) Standard #7 requirements for construction, materials and cleanability.

Engineering Plan View

**IM3SL/IM4SL/
IM5SL/IP2SL/
IP4SL**

Dimensions shown as in. and (mm).

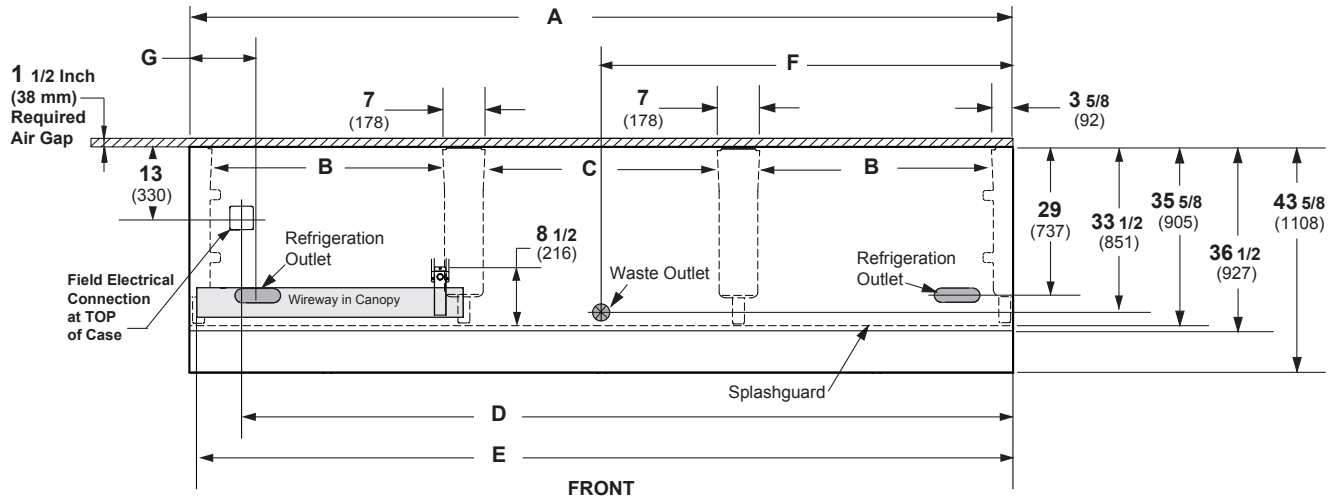

(12 Foot Model shown above)

	4 ft	6 ft	8 ft	12 ft
General				
(A) Case Length (without ends or partitions) (Each end and insulated partition adds 1 1/2 in. (38 mm) to case line up.)	48 1/8 (1222)	72 1/4 (1835)	96 1/4 (2445)	144 3/8 (3668)
Maximum O/S dimension of case back to front (includes bumper)	43 5/8 (1108)	43 5/8 (1108)	43 5/8 (1108)	43 5/8 (1108)
Back of case to front of splashguard	35 5/8 (905)	35 5/8 (905)	35 5/8 (905)	35 5/8 (905)
(B) Distance between edges of external legs and center legs	NA	29 (737)	41 (1041)	41 (1041)
(C) Distance between edges of center legs	41 1/8 (1045)	NA	NA	41 1/8 (1045)
Distance between front legs and splashguard	8 (203)	8 (203)	8 (203)	8 (203)
Electrical Service (Field Electrical Wiring Connection)				
(D) RH End of case to center of Field Electrical Wiring Connection (top of case)	39 3/8 (1000)	63 1/2 (1613)	87 1/2 (2223)	135 1/2 (3442)
Back of case to center of Field Electrical Wiring Connection	13 (330)	13 (330)	13 (330)	13 (330)
Length of electrical wireway	44 5/8 (1133)	33 1/2 (851)	45 7/8 (1191)	45 7/8 (1191)
(E) RH end of case to LH end of electrical wireway (top of case)	46 1/2 (1181)	70 1/2 (1791)	94 1/2 (2400)	142 5/8 (3623)
Waste Outlets				
(F) RH End of case to the center of waste outlet	24 1/8 (613)	24 1/8 (613)	24 1/8 (613)	72 1/4 (1835)
Back O/S of case to center of waste outlet(s)	33 1/2 (851)	33 1/2 (851)	33 1/2 (851)	33 1/2 (851)
Schedule 40 PVC drip pipe	1 1/4 (32)	1 1/4 (32)	1 1/4 (32)	1 1/4 (32)
Refrigeration Outlet				
(G) Back of case to center of refrigeration outlet	29 (737)	29 (737)	29 (737)	29 (737)
End of case to center of refrigeration outlet	8 1/2 (216)	8 1/2 (216)	8 1/2 (216)	8 1/2 (216)

Electrical Data

Number of Fans	4 ft	6 ft	8 ft	12 ft
8.25-in.	-	2	-	-
10.3-in.	1	-	2	3

Evaporator Fan	Amperes				Watts			
	4 ft	6 ft	8 ft	12 ft	4 ft	6 ft	8 ft	12 ft
120V 60Hz Energy Efficient	0.40	0.60	0.80	1.20	24	36	48	72
230V 50/60Hz Energy Efficient	0.21	0.31	0.42	0.62	24	36	48	72

Minimum Circuit Ampacity				
120V 60Hz Energy Efficient	0.60	0.80	1.00	1.40
230V 50/60Hz Energy Efficient	0.41	0.51	0.62	0.82

Maximum Over Current Protection 120V	20	20	20	20
Maximum Over Current Protection 230V	15	15	15	15

Lighting

ONLY LIGHTING CONFIGURATIONS THAT ARE COMPLIANT WITH THE U.S. DEPT. OF ENERGY (DOE) 2017 REGULATION ARE AVAILABLE FOR SALE FOR USE IN THE U.S.A.

	Amperes				Watts			
	4 ft	6 ft	8 ft	12 ft	4 ft	6 ft	8 ft	12 ft
STANDARD LED LIGHTING								
LED Canopy Lights								
1 Row	0.16	0.22	0.31	0.47	19	27	38	57
OPTIONAL LED LIGHTING								
2 Rows of Canopy Lights	0.32	0.44	0.62	0.94	38	54	76	114
LED SHELF LIGHTING								
1 Row of Shelves	0.06	0.07	0.11	0.17	7	9	13	20
2 Rows of Shelves	0.11	0.15	0.22	0.33	13	18	27	40
3 Rows of Shelves	0.17	0.22	0.33	0.50	20	27	40	60
4 Rows of Shelves	0.22	0.30	0.44	0.67	27	36	53	80
5 Rows of Shelves	0.28	0.37	0.56	0.83	33	44	67	100
LED Rail Light								
1 Row	0.06	0.07	0.11	0.17	7	9	13	20

120V Lighting Circuit Total = Standard Lighting + Total Optional Lighting + Optional Shelf Lighting

230V Lighting Circuit Total = Multiply 120V Lighting Circuit Total by 0.52

Insight IM5SL
Meat & Delicatessen

ENDS or PARTITIONS

Each standard end and each insulated partition adds 1 1/2 in. (38 mm) to case line up. Optional view end with end bumper adds 3 3/4 in. (95 mm).

PHYSICAL DATA

Merchandiser Drip Pipe (in.)	1 1/4
Schedule 40 PVC	
Merchandiser Liquid Line (in.)	3/8
Merchandiser Suction Line (in.)	5/8

ESTIMATED SHIPPING WEIGHT †

Case	4 ft	6 ft	8 ft	12 ft	Solid End (each)
lb (kg)	700 (318)	850 (386)	950 (431)	1200 (544)	70 (32)

† Actual weights will vary according to optional kits included.

Shelf Options

Approved shelf sizes for standard (horizontal, 2-3 position brackets) displays:

- 14-inch
- 16-inch
- 18-inch
- 20-inch
- 22-inch

Contact engineering for non-standard (4 position brackets or other) display recommendations.

Minimum number of Shelves: 3

Optimal number of Shelves: 4

Maximum number of Shelves: 6

Maximum number of Lighted Shelves: 5

Standard shelf complement for test purposes: (4) rows of shelves (14-in., 16-in., 18-in., 18-in.), all down-tilted at 15° with a 12-in. mirror, spacing between each row of shelves is 9-in.

Fan Wiring Offtime Defrost

Insight IM5SL
Meat & Delicatessen

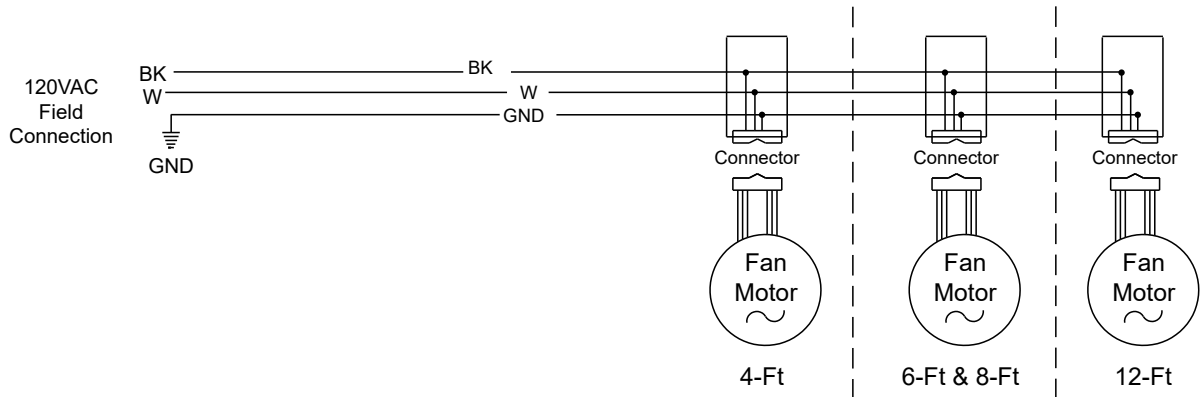

LED Canopy Light Circuits

LED Canopy Lighting - 2 Rows

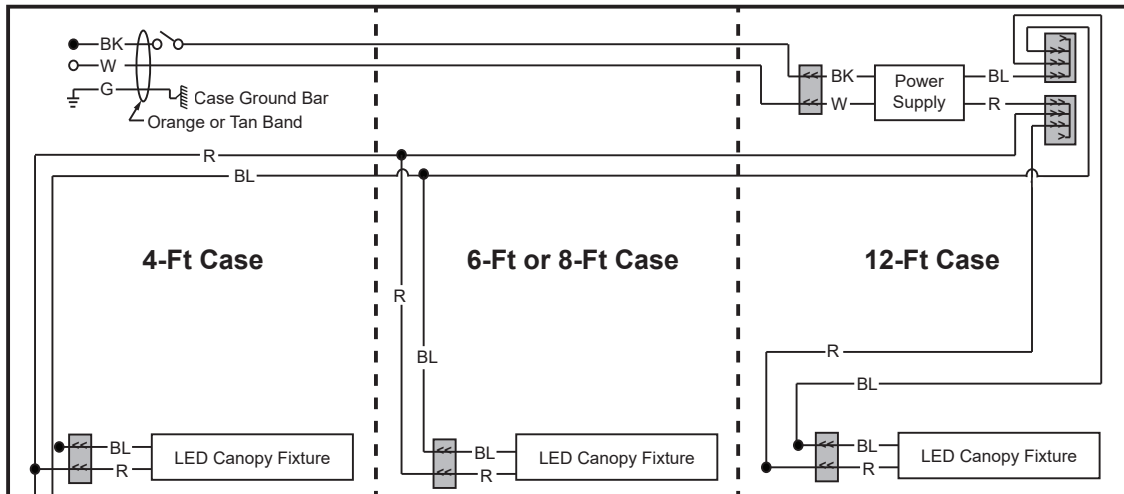

Optional LED Lighting - LED Rail - 1 Row

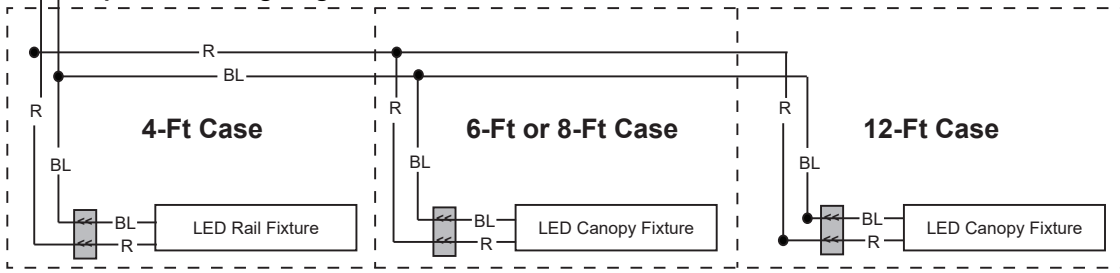

WARNING

All components must have mechanical ground, and the merchandiser must be grounded.

R = Red Y = Yellow G = Green BL = Blue BK = Black W = White
 ● = 120V POWER ○ = 120V NEUTRAL ⊥ = FIELD GROUND ▨ = CASE GROUND

Optional Shelf Harness and LED Light Circuits for 2 or 3 Rows of Shelves

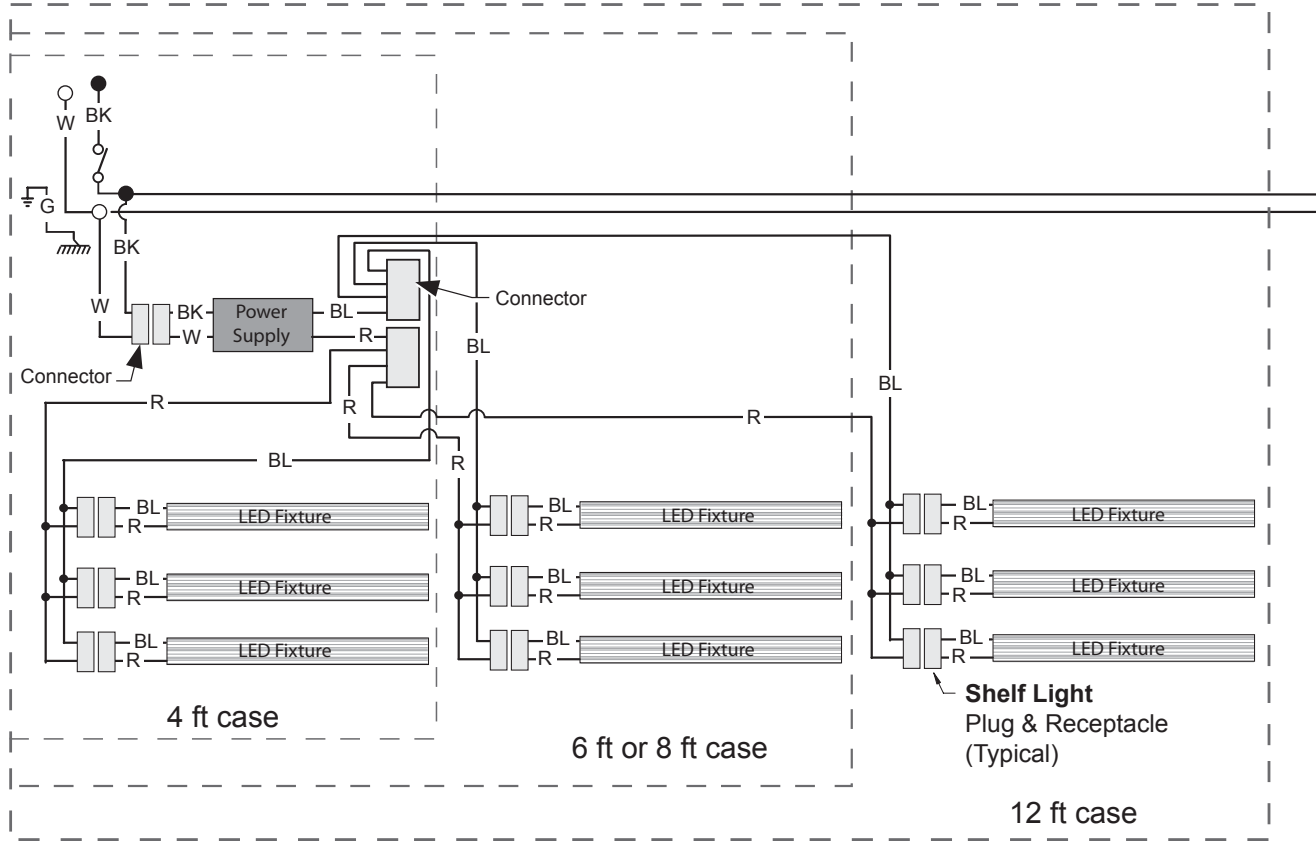

WARNING

All components must have mechanical ground, and the merchandiser must be grounded.

R = Red Y = Yellow G = Green BL = Blue BK = Black W = White
 ● = 120V POWER ○ = 120V NEUTRAL ⊥ = FIELD GROUND mmm = CASE GROUND

Optional Shelf Harness and LED Light Circuits for 4 or 5 Rows of Shelves

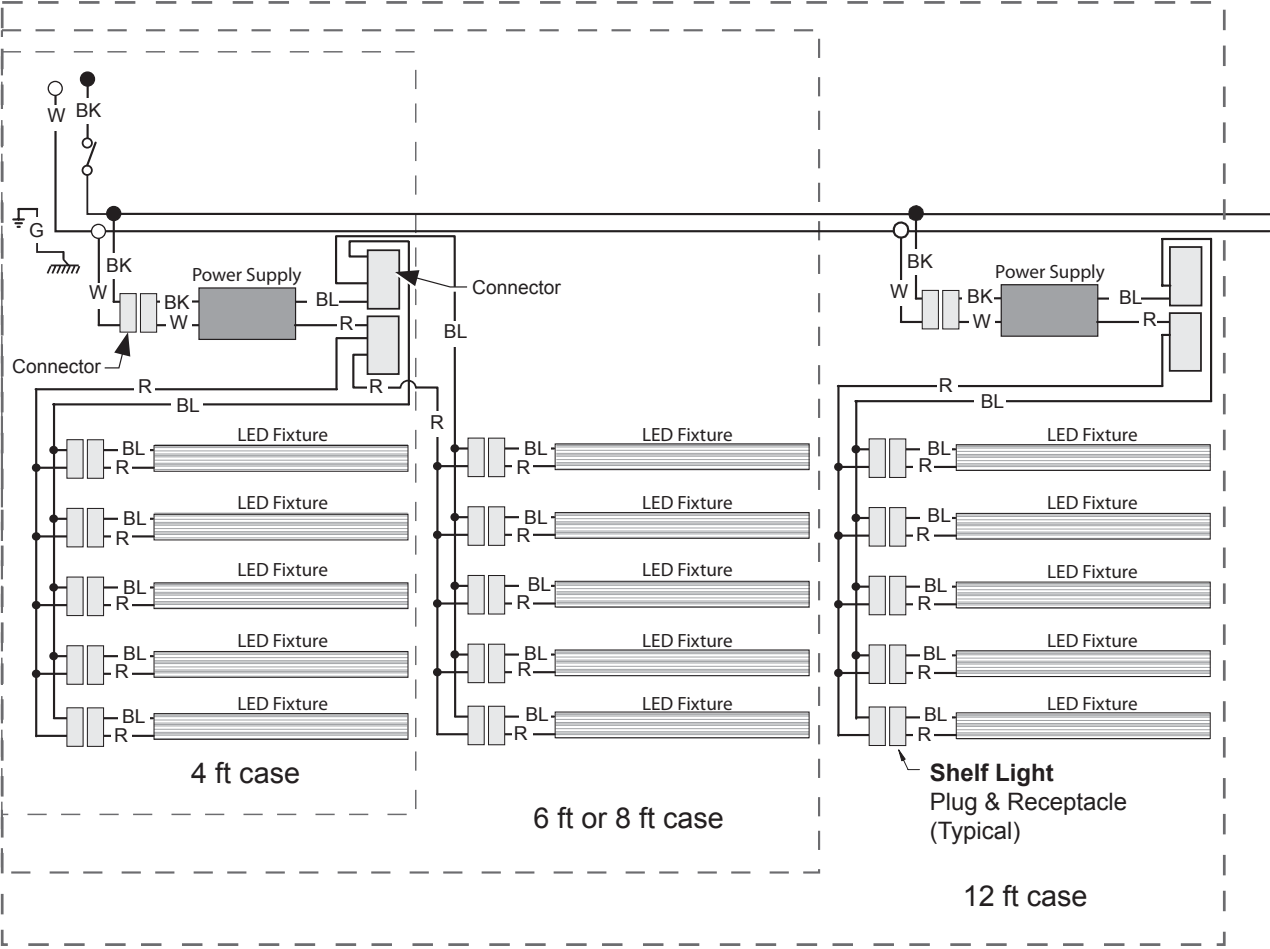

WARNING

All components must have mechanical ground, and the merchandiser must be grounded.

- R = Red Y = Yellow G = Green BL = Blue BK = Black W = White
- = 120V POWER ○ = 120V NEUTRAL ⊥ = FIELD GROUND mm = CASE GROUND

Estimating Refrigeration and Electrical Load (for comparison purposes only)

Case Btu

To determine Btu for a case, refer to the performance data chart on page 2. Select lit or unlit shelves, then select the type of remote refrigeration system (parallel or conventional), which will give Btu/hr/ft. Multiply this number by the length of the case to determine Btu per hour. Add 10 Btu/Hr/Ft for each row of LED shelf lights.

Case Electrical

Refer to store legend to determine number of circuits. Lighting should be specified in store legend.

Fan electrical load for a case is computed by selecting the case length and fan voltage on page 6. For example, a 12 ft case uses 3 fans. The store legend specifies fans on a 230V circuit. In this instance, fans use 0.62 Amps and the MCA is 0.82. When applied, ambient fans, anti-sweat heaters, controllers, etc. must be included in the MCA. Include lights in the MCA if lights are on same circuit.

Lights may be on a separate circuit. To estimate lighting load: select case length (12 ft), canopy lighting [standard or optional] (here 0.70 for standard), and shelf or rail lighting [maximum for which case is wired] (1.24 for five shelves); then add together [0.48 + 1.24 = 1.72 amps for 120V] (for 230V, multiply 1.72 * 0.52 = 0.89).

Line Sizing — Refer to store legend.

Hussmann Line Sizing Charts are engineered for use with Hussmann refrigeration equipment.



Scan the QR code with your mobile device to access additional product information or order parts.

Parts may also be ordered at:

parts.hussmann.com

Call toll free: 1.855.487.7778

Revision History

Revision A: August 2013: Original Issue

Revision B: October 2015: Updated application data.

Revision C: December 2015: Updated cross section and plan view.

Revision D: April 2016: Updated cover image, updated application data, added Gross Refrigerated Volume, added optional glass front kit and updated plan view.

Revision E: August 2016: Updated cross section and plan view.

Revision F: January 2017: Added rail light updates.

Revision G: April 2017. Updated LED energy values.

Revision H: April 2017. Updated LED energy values.

Revision J: September 2017. Updated notes page. Other changes marked with a bar, circle or underline.

Revision K: January 2023. Added CO₂ note, Page 2.

Revision L: November 2023: Updated fan and lighting information.