

Insight standard field electrical connections are at the bottom of the merchandiser

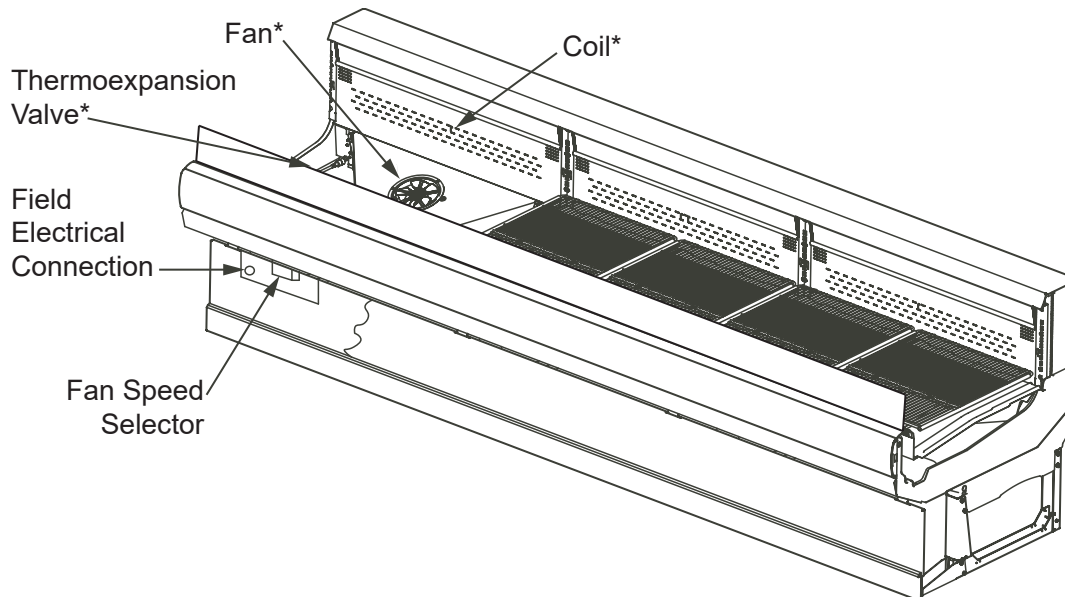

*Coils, fans and TXVs are modular with one per 3 or 4 foot section.

Portion of parts removed for clarity.

12 foot merchandiser shown.

NSF Certification

This merchandiser model is manufactured to meet NSF/ANSI (National Sanitation Foundation) Standard #7 requirements for construction, materials and cleanability.

Performance Data	Page 2	Electrical Loads	Page 6
Product Data (AHRI Statistics)	Page 2	Wiring Diagrams	Page 7
Cross Section	Page 3	Computing Refrigeration and Electrical Load	Page 8
Plan View	Page 4	QR Code and Revision History	Page 8
Estimated Shipping Weights	Page 5		

Data sheet-Insight IM1SL

We reserve the right to change or revise specifications and product design in connection with any feature of our products. Such changes do not entitle the buyer to corresponding changes, improvements, additions or replacements for equipment previously sold or shipped.

Insight IM1SL

Meat

Refrigeration Data ¹

IM1SL		Optional Shelf Light		Energy Comparison
Application		Meat with Glass Front ³	NSF Type 2 Ambient ⁴	AHRI 1200 Rating Point ⁵
Unlit	Discharge Air °F (°C)	32 (0)	28 (-2.22)	30 (-1.11)
	Average Evaporator °F (°C) ²	27 (-2.77)	23 (-5.00)	25 (-3.88)
	Parallel Btu/hr/ft (Watts/m)	340 (327)	475 (457)	415 (399)
	Conventional Btu/hr/ft (Watts/m)	385 (370)	535 (514)	465 (447)
Lit	Discharge Air °F (°C)	N/A	N/A	N/A
	Average Evaporator °F (°C) ²	N/A	N/A	N/A
	Parallel Btu/hr/ft (Watts/m)	N/A	N/A	N/A
	Conventional Btu/hr/ft (Watts/m)	N/A	N/A	N/A
Fan Speed ⁶	IM1SL6 (7")	1200 ⁶	1200 ⁶	1200 ⁶
	IM1SL4, 8, 12 (7")	1200 ⁶	1200 ⁶	1200 ⁶

Notes:

- All data based on store temperature and humidity that does not exceed NSF Type 1 ambient conditions of 75°F and 55% relative humidity except where noted.
- Average evaporator temperature shown. Use dew point for high glide refrigerants for unit sizing. Care should be taken to use the dew point in PT tables for measuring and adjusting superheat. Adjust evaporator pressure as needed to maintain discharge air temperature shown.
- See second column of data for glass front loads and settings.
- Data for operation in NSF Type 2 ambient of 80°F and 55% relative humidity.
- AHRI 1200 Rating Point for energy consumption comparison only.
- Some lengths and/or applications require optional fan motor kits applied by the Hussmann Product Configurator (HPC).

Defrost Data

Frequency (hours between defrost) 6

OFFTIME **IM1SL**
Time (minutes) 40

ELECTRIC OR GAS Not Available

Defrost Water ⁷ 2.5 lb/ft/day
(3.7 kg/m)

⁷ (± 15% based on case configuration and product loading).

Conventional Controls

IM1SL
Low Pressure Backup Control CI/CO ⁸
18°F / 8°F
-7.78°C / -13.3°C

Indoor Unit Only, Pressure Defrost Termination ⁸
48°F (8.89°C)

⁸ Use a Temperature Pressure Chart to determine PSIG conversions.

Estimated Charge ⁹

	IM1SL	
4 ft	0.5 lb	8 oz
6 ft	0.8 lb	13 oz
8 ft	1.1 lb	18 oz
12 ft	1.9 lb	30 oz

⁹ This is an average for all refrigerant types. Actual refrigerant charge may vary by approximately half a pound.

Product Data

Gross Refrigerated Volume ¹⁰ (Cu Ft/Ft) 1.7 ft³/ft (0.16 m³/m)

AHRI Total Display Area ¹¹ (Sq Ft/Ft) 2.58 ft²/ft (0.79 m²/m)

Shelf Area ¹² (Sq Ft/Ft) 2.52 ft²/ft (0.77 m²/m)

¹⁰ AHRI Gross Refrigerated Volume: Refrigerated Volume/Unit of Length, ft³/ft [m³/m]

¹¹ Computed using AHRI 1200 standard methodology: Total Display Area, ft² [m²]/Unit of Length, ft [m]

¹² Shelf surface area is composed of bottom deck plus standard shelf complement for this model: None.

Insight Single Deck Merchandiser, 1 Display Level,
Standard Bottom, Standard Height Front



DOE 2017
Energy Efficiency
Compliant

Husmann refrigerated merchandisers configured for sale for use in the United States meet or surpass the requirements of the DOE 2017 energy efficiency standards.

3-in. between back to back cases.

Dimensions shown as in. and (mm).

Shelf complement shown as tested:

No shelves; wire racks are angled up in the back, positioned 6-in. above the bottom-most (flat) location.

IM1SL

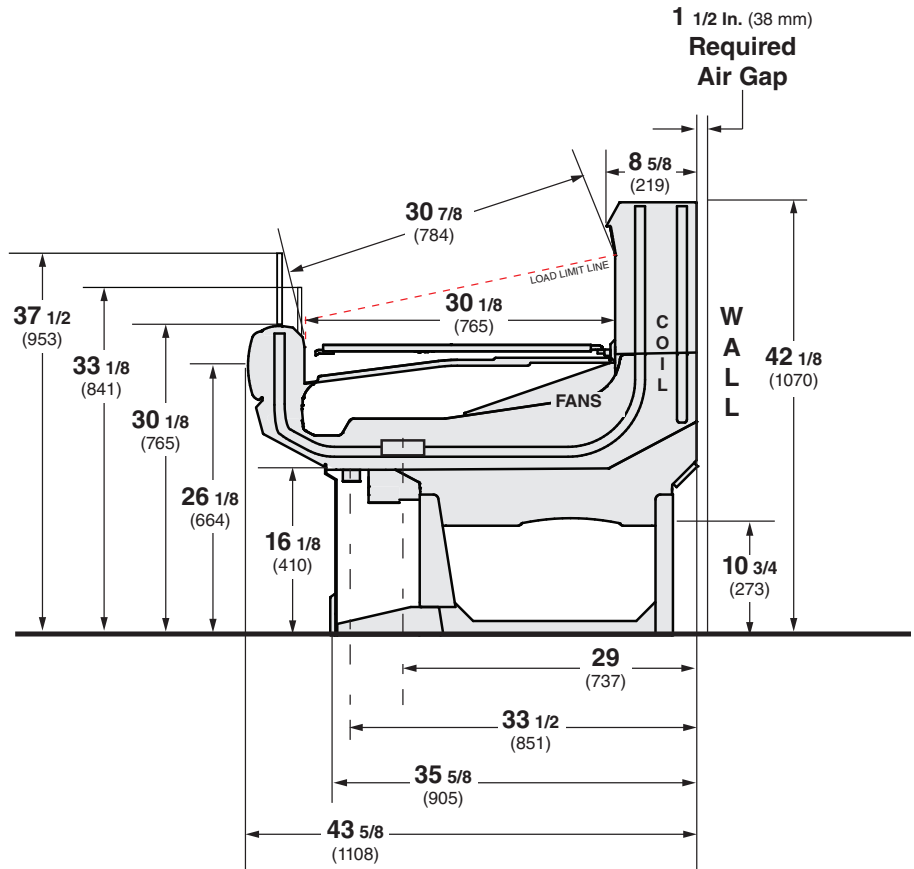

STANDARD GLASS FRONT

Glass front is standard for this case.

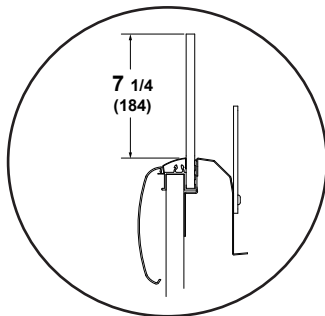

Glass front cannot be used with rail light option.

NSF Certification

This merchandiser model is manufactured to meet NSF/ANSI (National Sanitation Foundation) Standard #7 requirements for construction, materials and cleanability.

Engineering Plan View

Dimensions shown as in. and (mm).

IM1SL/IM1SM/ IP1SL

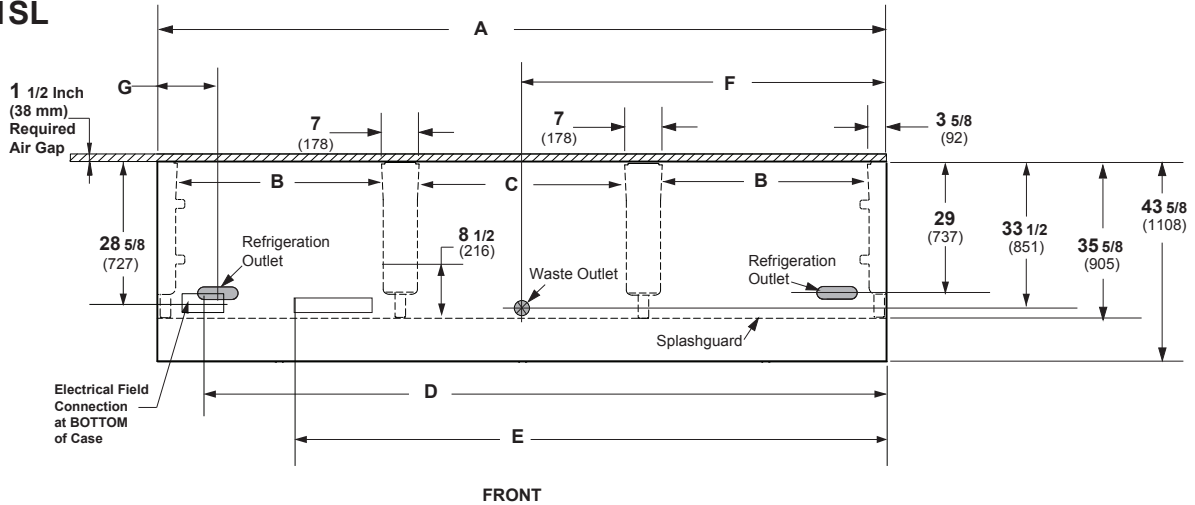

(12 Foot Model shown above)

	4 ft	6 ft	8 ft	12 ft
General				
(A) Case Length (without ends or partitions) (Each end and insulated partition adds 1 1/2 in. (38 mm) to case line up.)	48 1/8 (1222)	72 1/4 (1835)	96 1/4 (2445)	144 3/8 (3668)
Maximum O/S dimension of case back to front (includes bumper)	43 5/8 (1108)	43 5/8 (1108)	43 5/8 (1108)	43 5/8 (1108)
Back of case to front of splashguard	35 5/8 (905)	35 5/8 (905)	35 5/8 (905)	35 5/8 (905)
(B) Distance between edges of external legs and center legs	NA	29 (737)	41 (1041)	41 (1041)
(C) Distance between edges of center legs	41 1/8 (1045)	NA	NA	41 1/8 (1045)
Distance between front legs and splashguard	8 (203)	8 1/8 (206)	8 1/8 (206)	8 1/8 (206)
Electrical Service (Field Electrical Wiring Connection)				
(D) RH End of case to center of Field Electrical Wiring Connection (bottom of case)	12 (305)	60 1/4 (1530)	84 3/8 (2143)	132 1/2 (3366)
Back of case to center of Field Electrical Wiring Connection	28 5/8 (727)	28 5/8 (727)	28 5/8 (727)	28 5/8 (727)
Length of electrical wireway	20 (508)	20 (508)	20 (508)	20 (508)
(E) RH end of case to LH end of electrical wireway (bottom of case)	44 3/4 (1137)	26 1/2 (673)	71 3/4 (1822)	119 3/4 (3042)
Waste Outlets				
(F) RH End of case to the center of waste outlet	24 1/8 (613)	24 1/8 (613)	24 1/8 (613)	72 1/4 (1835)
Back O/S of case to center of waste outlet(s)	33 1/2 (851)	33 1/2 (851)	33 1/2 (851)	33 1/2 (851)
Schedule 40 PVC drip pipe	1 1/4 (32)	1 1/4 (32)	1 1/4 (32)	1 1/4 (32)
Refrigeration Outlet				
(G) Back of case to center of refrigeration outlet	29 (737)	29 (737)	29 (737)	29 (737)
End of case to center of refrigeration outlet	8 1/2 (216)	8 1/2 (216)	8 1/2 (216)	8 1/2 (216)

ENDS or PARTITIONS

Each standard end and each insulated partition adds 1 1/2 in. (38 mm) to case line up. Optional view end with end bumper adds 3 3/4 in. (95 mm).

PHYSICAL DATA

Merchandise Drip Pipe (in.)	1 1/4
Schedule 40 PVC	
Merchandise Liquid Line (in.)	3/8
Merchandise Suction Line (in.)	5/8

ESTIMATED SHIPPING WEIGHT †

Case	4 ft	6 ft	8 ft	12 ft	Solid End (each)
lb (kg)	500 (227)	575 (261)	625 (284)	750 (340)	40 (18)

† Actual weights will vary according to optional kits included.

Electrical Data

Number of Fans	4 ft	6 ft	8 ft	12 ft
7.0 in.	1	2	2	3

Evaporator Fan	Amperes				Watts			
	4 ft	6 ft	8 ft	12 ft	4 ft	6 ft	8 ft	12 ft
120V 60Hz Energy Efficient	0.12	0.24	0.24	0.36	8	16	16	24
230V 50/60Hz Energy Efficient	0.06	0.12	0.12	0.18	8	16	16	24

Minimum Circuit Ampacity				
120V 60Hz Energy Efficient	0.32	0.44	0.44	0.56
230V 50/60Hz Energy Efficient	0.26	0.32	0.32	0.38

Maximum Over Current Protection 120V	20	20	20	20
Maximum Over Current Protection 230V	15	15	15	15

ONLY LIGHTING CONFIGURATIONS THAT ARE COMPLIANT WITH THE U.S. DEPT. OF ENERGY (DOE) 2017 REGULATION ARE AVAILABLE FOR SALE FOR USE IN THE U.S.A.

STANDARD LIGHTING

None

OPTIONAL LIGHTING

Rail Light

1 Row	0.06	0.07	0.11	0.17	7	9	13	20
-------	------	------	------	------	---	---	----	----

SHELF OPTIONS

None

Fan Wiring Offtime Defrost

Insight IM1SL
Meat

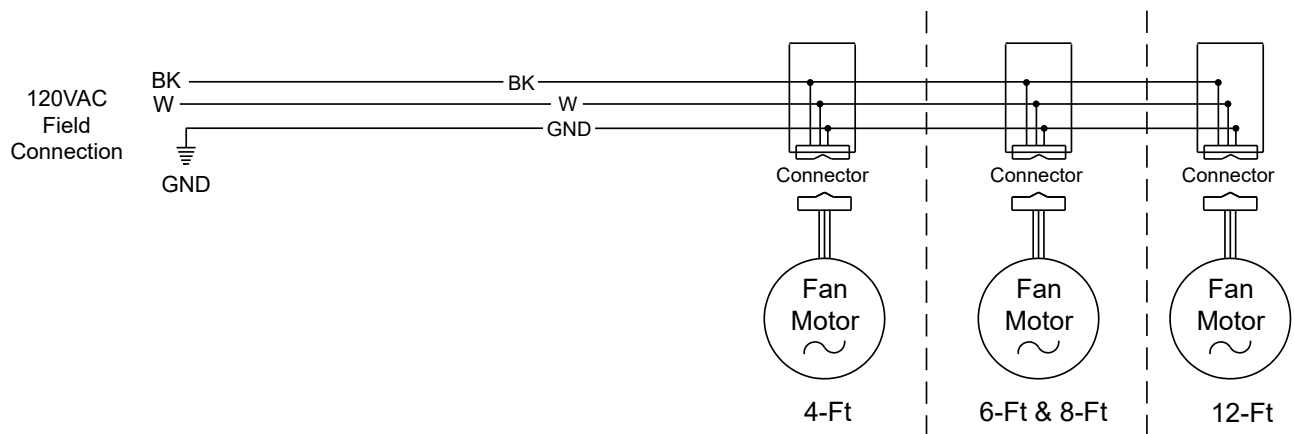

LED Canopy Light Circuits

Optional Lighting - LED Rail - 1 Row

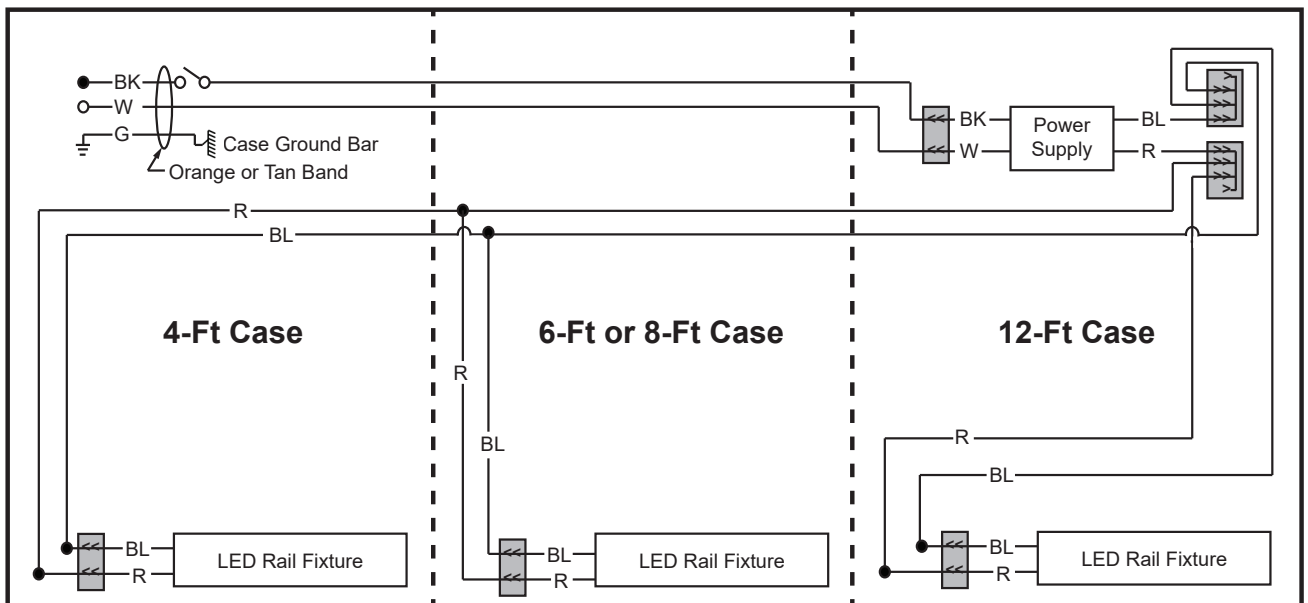

WARNING

All components must have mechanical ground, and the merchandiser must be grounded.

R = Red Y = Yellow G = Green BL = Blue BK = Black W = White
 ● = 120V POWER ○ = 120V NEUTRAL ⚡ = FIELD GROUND ⚡ = CASE GROUND

Estimating Refrigeration and Electrical Load (for comparison purposes only)

Case Btu

To determine Btu for a case, refer to the performance data chart on page 2. Select with or without front glass, then select the type of remote refrigeration system (parallel or conventional), which will give Btu/hr/ft. Multiply this number by the length of the case to determine Btu per hour. Add 10 BTU per foot per hour for each row of LED shelf or rail lights.

Case Electrical

Refer to store legend to determine number of circuits.

Fan electrical load for a case is computed by selecting the case length and fan voltage on page 6. For example, a 12 ft case uses 3 fans. The store legend specifies fans on a 230V circuit. In this instance, fans use 0.39 Amps and the MCA is 0.59. When applied, ambient fans, anti-sweat heaters, controllers, etc. must be included in the MCA. Include lights in the MCA if lights are on same circuit.

Line Sizing — Refer to store legend.

Hussmann Line Sizing Charts are engineered for use with Hussmann refrigeration equipment.



Scan the QR code with your mobile device to access additional product information or order parts.

Parts may also be ordered at:

parts.hussmann.com

Call toll free: 1.855.487.7778

Revision History

Revision A: August 2013: Original Issue

Revision B: October 2015: Updated application data.

Revision C: December 2015: Updated cross section and plan view.

Revision D: April 2016: Updated cover image, updated application data, added Gross Refrigerated Volume, added optional glass front kit and updated plan view.

Revision E: August 2016: Updated cross section.

Revision F: January 2017: Added rail light updates.

Revision G: April 2017: Updated LED energy values.

Revision H: September 2017: Updated notes page.

Revision J: February 2019: Updated optional glass front to standard.

Revision K: December 2023: Updated fan and lighting information. Removed replacement parts page. Updated wiring diagrams.