

*Insight standard field electrical connections are at the top left of the merchandiser*

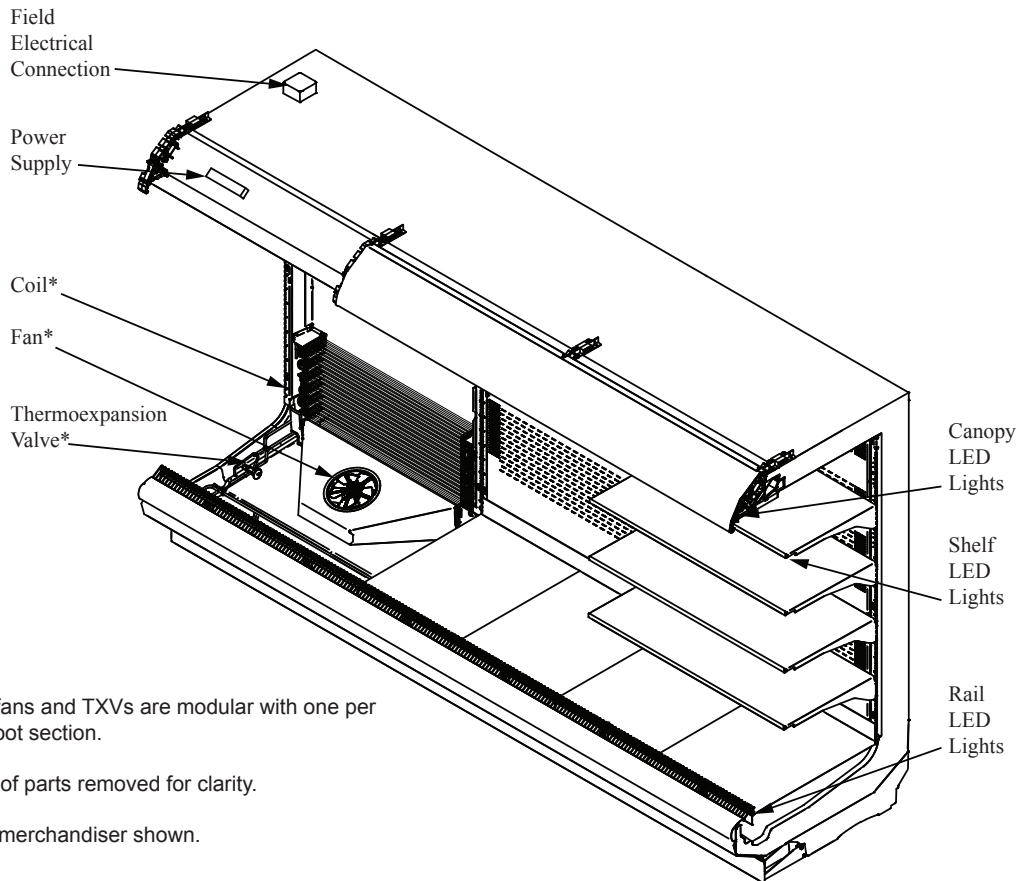

\*Coils, fans and TXVs are modular with one per 3 or 4 foot section.

Portion of parts removed for clarity.

12 foot merchandiser shown.



### NSF Certification

This merchandiser model is manufactured to meet NSF/ANSI (National Sanitation Foundation) Standard #7 requirements for construction, materials and cleanability.

Performance Data	Page 2	Estimated Shipping Weights	Page 6
Product Data (AHRI Statistics)	Page 2	Shelf Options	Page 6
Cross Section	Page 3	Wiring Diagrams	Page 7
Plan View	Page 4	Computing Refrigeration and Electrical Load	Page 10
Electrical Loads	Page 5	QR Code for Parts and Product Information	Page 10
		Revision History	Page 10

Data sheet-Insight ID5SV

We reserve the right to change or revise specifications and product design in connection with any feature of our products. Such changes do not entitle the buyer to corresponding changes, improvements, additions or replacements for equipment previously sold or shipped.

**Insight ID5SV**  
Dairy / Deli / Beverage /  
Produce / Meat

**Refrigeration Data <sup>1</sup>**

ID5SV		Optimal Shelf Life				Energy Comparison
Application		Dairy/Deli/ Beverage/ Produce	Convertible / Meat	NSF Type 2 Ambient <sup>3</sup>	Pegs <sup>4</sup>	AHRI 1200 Rating Point <sup>5</sup>
Unlit Shelves	Discharge Air °F (°C)	33 (0.55)	33 (0.55)	33 (0.55)	33 (0.55)	35 (1.66)
	Average Evaporator °F (°C) <sup>2</sup>	28 (-2.22)	26 (-3.33)	26 (-3.33)	26 (-3.33)	30 (-1.11)
	Parallel Btu/hr/ft (Watts/m) <sup>6</sup>	1285 (1236)	1416 (1362)	1714 (1648)	1659 (1595)	1200 (1154)
	Conventional Btu/hr/ft (Watts/m) <sup>6</sup>	1400 (1347)	1545 (1486)	1870 (1798)	1810 (1741)	1310 (1260)
Lit Shelves	Discharge Air °F (°C)	32 (0)	33 (0.55)	33 (0.55)	N/A	34 (1.11)
	Average Evaporator °F (°C) <sup>2</sup>	27 (-2.77)	25 (-3.88)	25 (-3.88)	N/A	29 (-1.66)
	Parallel Btu/hr/ft (Watts/m) <sup>6</sup>	1305 (1255)	1435 (1379)	1733 (1666)	N/A	1220 (1174)
	Conventional Btu/hr/ft (Watts/m) <sup>6</sup>	1420 (1366)	1565 (1505)	1890 (1817)	N/A	1330 (1279)
Fan Speed <sup>7</sup>	ID5SV6 (8.25")	1500 <sup>7</sup>	1700 <sup>7</sup>	1700 <sup>7</sup>	1700 <sup>7</sup>	1500 <sup>7</sup>
	ID5SV4, 8, 12 (8.25")	1500 <sup>7</sup>	1700 <sup>7</sup>	1700 <sup>7</sup>	1700 <sup>7</sup>	1500 <sup>7</sup>

Notes:

- All data based on store temperature and humidity that does not exceed NSF Type 1 ambient conditions of 75°F and 55% relative humidity except where noted.
- Average evaporator temperature shown. Use dew point for high glide refrigerants for unit sizing. Care should be taken to use the dew point in PT tables for measuring and adjusting superheat. Adjust evaporator pressure as needed to maintain discharge air temperature shown.
- Data for operation in NSF Type 2 ambient of 80°F and 55% relative humidity.
- Hussmann Peg Shelves for Dairy/Deli applications only.
- AHRI 1200 Rating Point for energy consumption comparison only.
- Add 10 Btu/hr/ft (9.6 Watts/m) per shelf row for LED shelf light fixtures.
- Some lengths and/or applications require optional fan motor kits applied by the Hussmann Product Configurator (HPC).
- Reduce refrigeration load by 15% if fitted with CaseShieldPTM.

**Defrost Data**

<b>Frequency</b> (hours between defrost)	4
<b>Defrost Water</b> <sup>9</sup>	10.0 lb/ft/day (14.9 kg/m)
<sup>9</sup> (± 15% based on case configuration and product loading).	
<b>OFFTIME</b>	<b>ID5SV</b>
<b>Time (minutes)</b>	20
<b>ELECTRIC OR GAS</b>	Not Available

**Conventional Controls**

<b>ID5SV</b>
<b>Low Pressure Backup Control CI/CO</b> <sup>10</sup>
20°F /10°F -6.7°C / -12.2°C
<b>Indoor Unit Only, Pressure Defrost Termination</b> <sup>10</sup>
48°F (8.9°C)

<sup>10</sup> Use a Temperature Pressure Chart to determine PSIG conversions.

**Estimated Charge <sup>11</sup>**

	ID5SV	
<b>4 ft</b>	0.6 lb	9.6 oz
<b>6 ft</b>	1.1 lb	17.6 oz
<b>8 ft</b>	1.5 lb	24 oz
<b>12 ft</b>	2.9 lb	46.4 oz

<sup>11</sup> This is an average for all refrigerant types. Actual refrigerant charge may vary by approximately half a pound.

**Product Data**

<b>Gross Refrigerated Volume</b> <sup>12</sup> (Cu Ft/Ft)	12.1 ft <sup>3</sup> /ft (1.12 m <sup>3</sup> /m)
<b>AHRI Total Display Area</b> <sup>13</sup> (Sq Ft/Ft)	5.05 ft <sup>2</sup> /ft (1.54 m <sup>2</sup> /m)
<b>Shelf Area</b> <sup>14</sup> (Sq Ft/Ft)	9.82 ft <sup>2</sup> /ft (2.99 m <sup>2</sup> /m)

<sup>12</sup> AHRI Gross Refrigerated Volume: Refrigerated Volume/Unit of Length, ft<sup>3</sup>/ft [m<sup>3</sup>/m]

<sup>13</sup> Computed using AHRI 1200 standard methodology: Total Display Area, ft<sup>2</sup> [m<sup>2</sup>]/Unit of Length, ft [m]

<sup>14</sup> Shelf surface area is composed of bottom deck plus standard shelf complement for this model: (4) rows of 22-in. shelves

Insight Multideck Merchandiser, 5 Display Levels,  
Standard Bottom, Very Low Height Front

**Insight ID5SV**  
Dairy / Deli / Beverage /  
Produce / Meat

**DOE 2017**  
Energy Efficiency  
Compliant

Husmann refrigerated merchandisers configured for sale for use in the United States meet or surpass the requirements of the DOE 2017 energy efficiency standards.

Dimensions shown as in. and (mm).

Other optional kits (top piping and vent fans) add to the overall case height.

A minimum 1 1/2-in. clearance required to remove raceway cover, 6 1/2-in for full access. See the Installation manual for instructions.

3-in. between back to back cases.

Shelf complement shown as tested:  
Four rows of 22-in. shelves spaced equally between bottom display pan and interior top panel.

Shown with Ellipse Option Canopy and Bumper.

**OPTIONAL RAIL LIGHT**

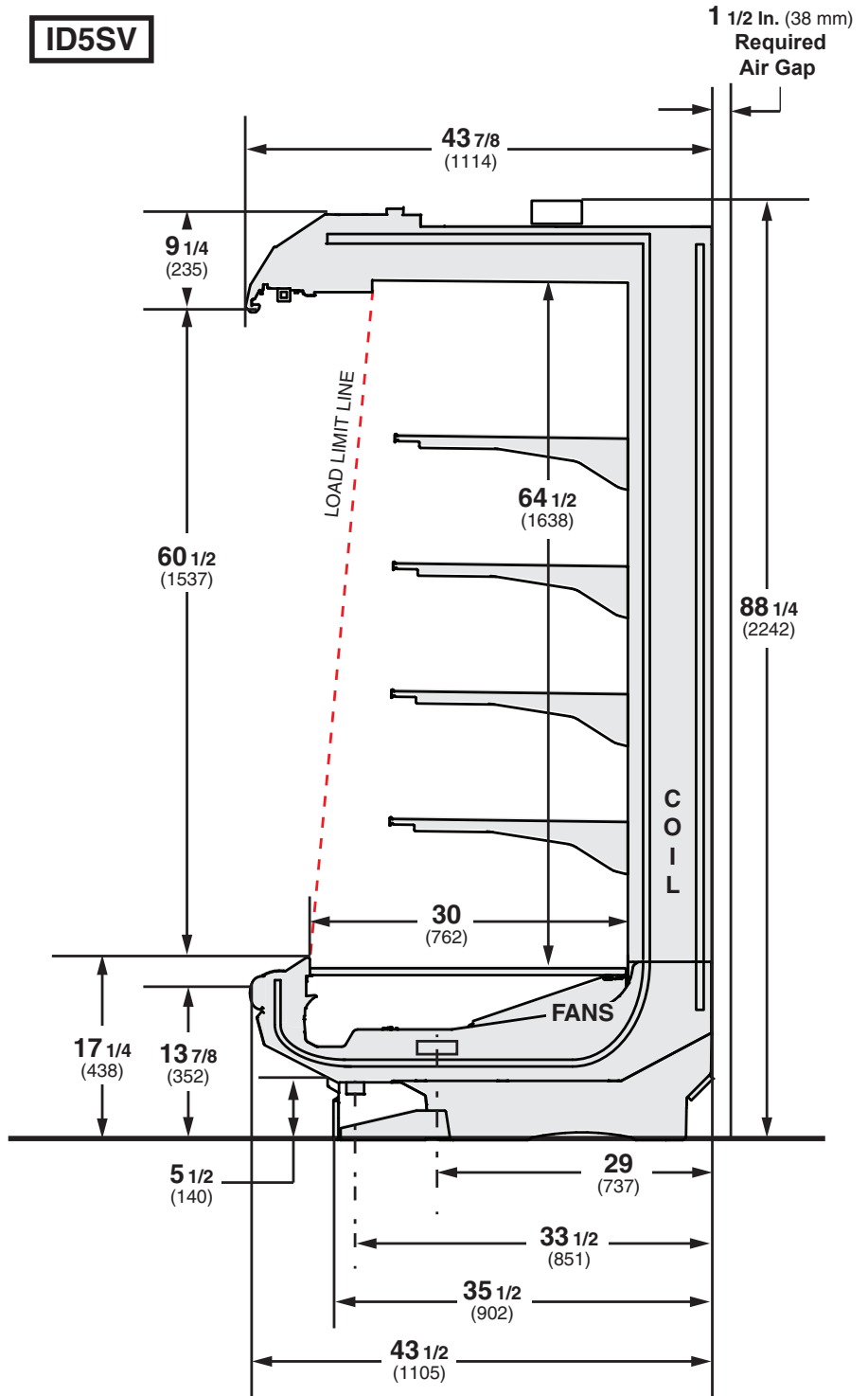
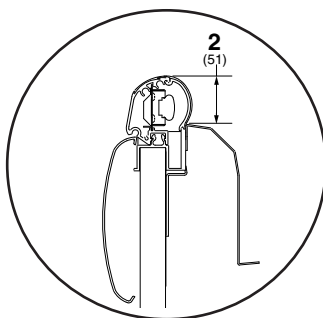

# Engineering Plan View

Dimensions shown as in. and (mm).

**ID5SU/ID6SU/  
ID5SV/ID6SV**

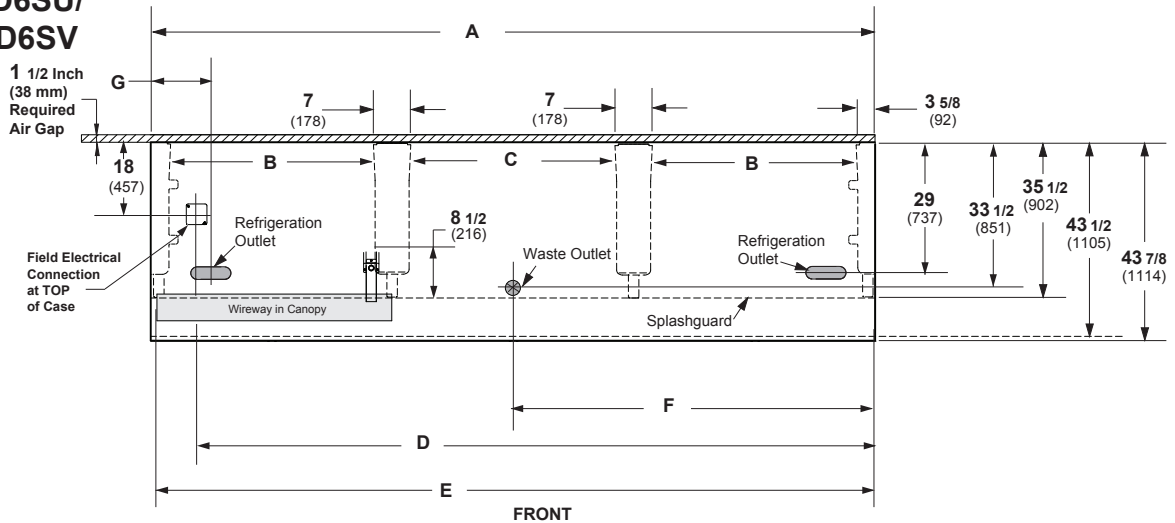

(12 Foot Model shown above)

	4 ft	6 ft	8 ft	12 ft
<b>General</b>				
(A) Case Length (without ends or partitions) (Each end and insulated partition adds 1 1/2 in. (38 mm) to case line up.)	48 1/8 (1222)	72 1/4 (1835)	96 1/4 (2445)	144 3/8 (3668)
Maximum O/S dimension of case back to front (includes bumper)	43 1/2 (1105)	43 1/2 (1105)	43 1/2 (1105)	43 1/2 (1105)
Back of case to front of splashguard	35 1/2 (902)	35 1/2 (902)	35 1/2 (902)	35 1/2 (902)
(B) Distance between edges of external legs and center legs	NA	29 (737)	41 (1041)	41 (1041)
(C) Distance between edges of center legs	41 1/8 (1045)	NA	NA	41 1/8 (1045)
Distance between front legs and splashguard	8 (203)	8 (203)	8 (203)	8 (203)
<b>Electrical Service (Field Electrical Wiring Connection)</b>				
(D) RH End of case to center of Field Electrical Wiring Connection (top of case)	39 3/8 (1000)	63 1/2 (1613)	87 1/2 (2223)	135 1/2 (3442)
Back of case to center of Field Electrical Wiring Connection	18 (457)	18 (457)	18 (457)	18 (457)
Length of electrical wireway	44 5/8 (1133)	33 1/2 (851)	45 7/8 (1165)	45 7/8 (1165)
(E) RH end of case to LH end of electrical wireway (top of case)	46 1/2 (1181)	70 1/2 (1791)	94 1/2 (2400)	142 5/8 (3630)
<b>Waste Outlets</b>				
(F) RH End of case to the center of waste outlet	24 1/8 (613)	24 1/8 (613)	24 1/8 (613)	72 1/4 (1835)
Back O/S of case to center of waste outlet(s)	33 1/2 (851)	33 1/2 (851)	33 1/2 (851)	33 1/2 (851)
Schedule 40 PVC drip pipe	1 1/4 (32)	1 1/4 (32)	1 1/4 (32)	1 1/4 (32)
<i>Floor Drain must be located within 24 inches of Waste Outlet.</i>				
<b>Refrigeration Outlet</b>				
(G) Back of case to center of refrigeration outlet	29 (737)	29 (737)	29 (737)	29 (737)
End of case to center of refrigeration outlet	8 1/2 (216)	8 1/2 (216)	8 1/2 (216)	8 1/2 (216)

## Electrical Data

<b>Number of Fans</b>	<b>4 ft</b>	<b>6 ft</b>	<b>8 ft</b>	<b>12 ft</b>
8.25-in.	1	2	2	3

	<b>Amperes</b>				<b>Watts</b>			
	<b>4 ft</b>	<b>6 ft</b>	<b>8 ft</b>	<b>12 ft</b>	<b>4 ft</b>	<b>6 ft</b>	<b>8 ft</b>	<b>12 ft</b>
<b>Evaporator Fan</b>								
120V 60Hz Energy Efficient	0.32	0.64	0.64	0.96	17	34	34	51
230V 50/60Hz Energy Efficient	0.17	0.33	0.33	0.50	17	34	34	51

### Minimum Circuit Ampacity

120V 60Hz Energy Efficient	0.52	0.84	0.84	1.16
230V 50/60Hz Energy Efficient	0.37	0.53	0.53	0.70

### Maximum Over Current Protection

120V	20	20	20	20
230V	15	15	15	15

## Lighting

ONLY LIGHTING CONFIGURATIONS THAT ARE COMPLIANT WITH THE U.S. DEPT. OF ENERGY (DOE) 2017 REGULATION ARE AVAILABLE FOR SALE FOR USE IN THE U.S.A.

	<b>Amperes</b>				<b>Watts</b>			
	<b>4 ft</b>	<b>6 ft</b>	<b>8 ft</b>	<b>12 ft</b>	<b>4 ft</b>	<b>6 ft</b>	<b>8 ft</b>	<b>12 ft</b>
<b>LED LIGHTING</b>								
<b>Standard LED Canopy Lights</b>								
1 Row LED Canopy (Standard)	0.16	0.22	0.31	0.47	19	27	38	57
<b>Optional LED Shelf Lights</b>								
1 Row of Shelves	0.06	0.07	0.11	0.17	7	9	13	20
2 Rows of Shelves	0.11	0.15	0.22	0.33	13	18	27	40
3 Rows of Shelves	0.17	0.22	0.33	0.50	20	27	40	60
4 Rows of Shelves	0.22	0.30	0.44	0.67	27	36	53	80
5 Rows of Shelves	0.28	0.37	0.56	0.83	33	44	67	100
6 Rows of Shelves	0.33	0.44	0.67	1.00	40	53	80	120
<b>Rail Light-1 Row</b>	0.06	0.07	0.11	0.17	7	9	13	20

120V Lighting Circuit Total = Standard Lighting + Total Optional Lighting + Optional Shelf Lighting

230V Lighting Circuit Total = Multiply 120V Lighting Circuit Total by 0.52

**Insight ID5SV**  
 Dairy / Deli / Beverage /  
 Produce / Meat

**ENDS or PARTITIONS**

*Each standard end and each insulated partition adds 1 1/2 in. (38 mm) to case line up. Optional view end with end bumper adds 3 3/4 in. (95 mm).*

**PHYSICAL DATA**

Merchandiser Drip Pipe (in.)	1 1/4
Schedule 40 PVC	
Merchandiser Liquid Line (in.)	3/8
Merchandiser Suction Line (in.)	7/8

**ESTIMATED SHIPPING WEIGHT †**

Case	4 ft	6 ft	8 ft	12 ft	Solid End (each)
lb (kg)	800 (363)	1000 (454)	1200 (544)	1600 (726)	100 (45)

† Actual weights will vary according to optional kits included.

## Shelf Options

Approved shelf sizes for standard (horizontal, 2-3 position brackets) displays:

18-inch  
 20-inch  
 22-inch  
 24-inch

Contact engineering for non-standard (4 position brackets or other) display recommendations.

Minimum number of Shelves: 4

Optimal number of Shelves: 4

Maximum number of Shelves: 8

Maximum number of Lighted Shelves: 6

Standard shelf complement for test purposes: (4) 22-in. shelves, evenly distributed vertically

# Fan Wiring Offtime Defrost

**Insight ID5SV**  
Dairy / Deli / Beverage /  
Produce / Meat

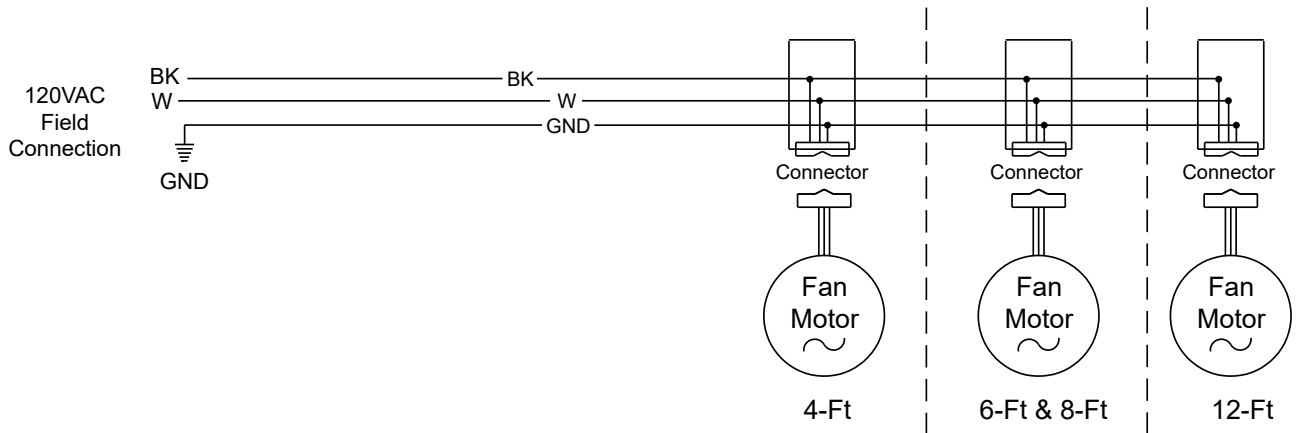

# LED Canopy Light Circuits

## LED Canopy Lighting - 1 Row

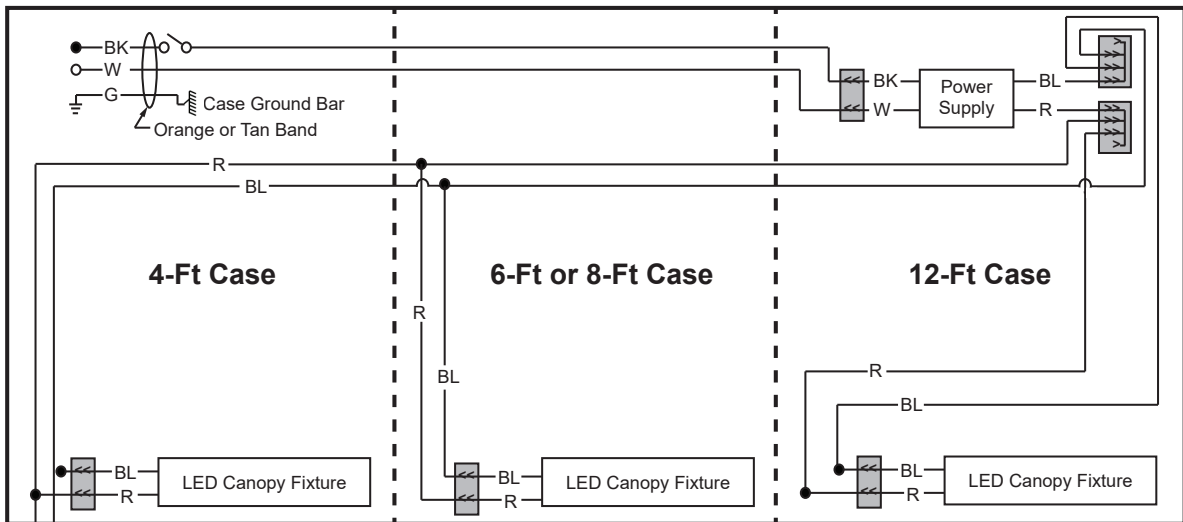

## Optional Lighting - LED Rail - 1 Row

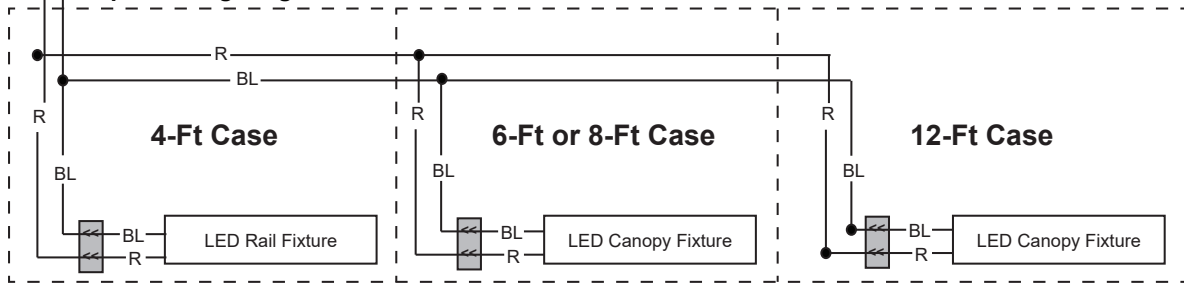

### WARNING

All components must have mechanical ground, and the merchandiser must be grounded.

R = Red   Y = Yellow   G = Green   BL = Blue   BK = Black   W = White  
 ● = 120V POWER   ○ = 120V NEUTRAL   ⚡ = FIELD GROUND   ▨ = CASE GROUND

**Shelf Harness and LED Light Circuits for 4 or 5 Rows of Shelves**

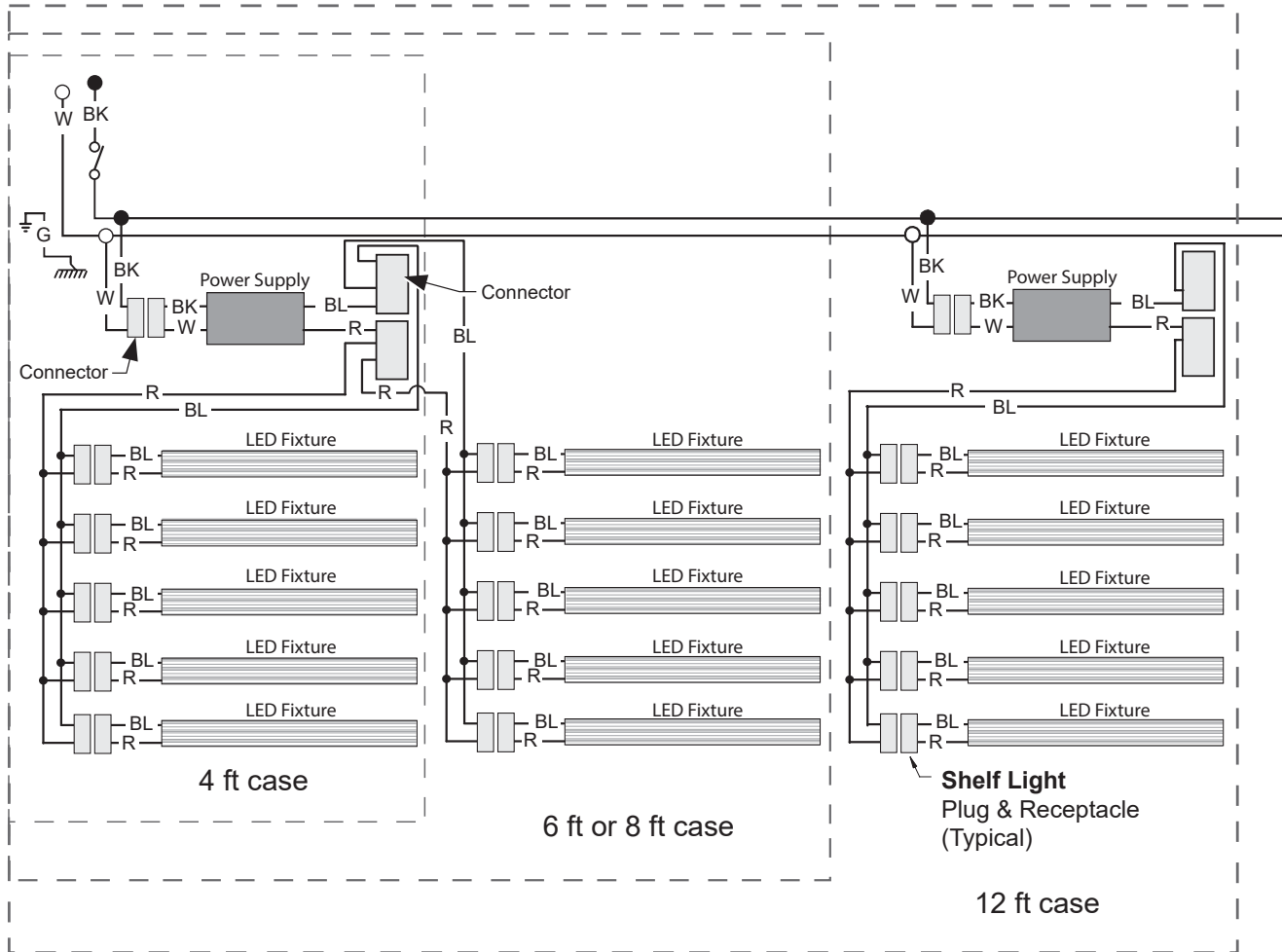

**WARNING**

All components must have mechanical ground, and the merchandiser must be grounded.

R = Red    Y = Yellow    G = Green    BL = Blue    BK = Black    W = White  
 ● = 120V POWER    ○ = 120V NEUTRAL    ⊥ = FIELD GROUND     $\overline{\overline{\overline{\quad}}}$  = CASE GROUND



**Optional LED Shelf Lighting**

**Insight ID5SV**  
Dairy / Deli / Beverage /  
Produce / Meat

**Shelf Harness and LED Light Circuits for 6 or 7 Rows of Shelves**

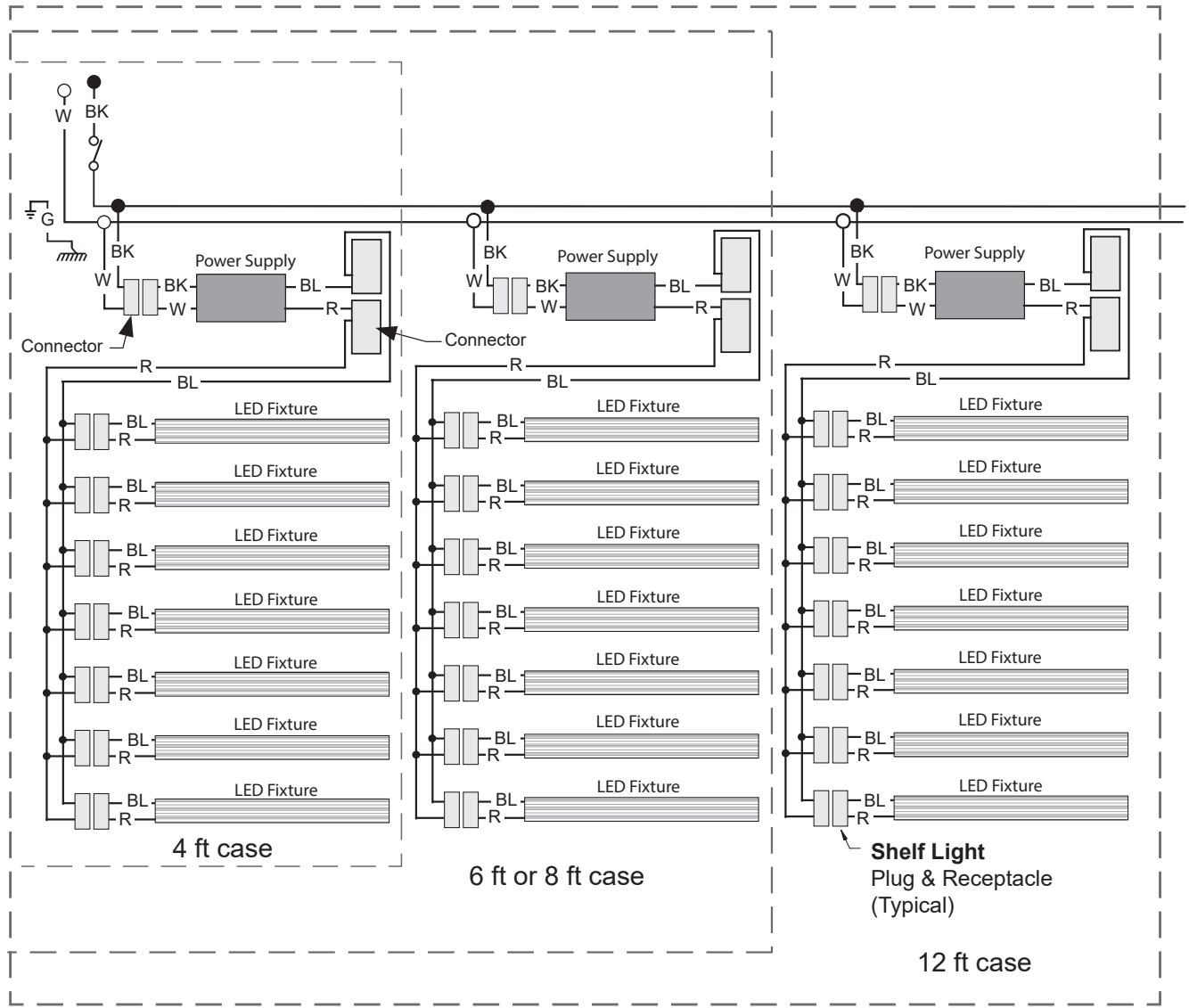

**WARNING**

All components must have mechanical ground, and the merchandiser must be grounded.

R = Red    Y = Yellow    G = Green    BL = Blue    BK = Black    W = White  
 ● = 120V POWER    ○ = 120V NEUTRAL    ⊥ = FIELD GROUND    ≡ = CASE GROUND

**Insight ID5SV**  
Dairy / Deli / Beverage /  
Produce / Meat

## Estimating Refrigeration and Electrical Load (for comparison purposes only)

### Case Btu

To determine Btu for a case, refer to the performance data chart on page 2. Select lit or unlit shelves, then select the type of remote refrigeration system (parallel or conventional), which will give Btu/hr/ft. Multiply this number by the length of the case to determine Btu per hour. Add 10 BTU per foot per hour for each row of LED shelf lights.

### Case Electrical

Refer to store legend to determine number of circuits. Lighting should be specified in store legend.

Fan electrical load for a case is computed by selecting the case length and fan voltage on page 6. For example, a 12 ft case uses 3 fans. The store legend specifies fans on a 230V circuit. In this instance, fans use 0.50 Amps and the MCA is 0.70. When applied, ambient fans, anti-sweat heaters, controllers, etc. must be included in the MCA. Include lights in the MCA if lights are on same circuit.

Lights may be on a separate circuit. To estimate lighting load: select case length (12 ft), canopy lighting [standard or optional] (here 0.70 for standard), and shelf or rail lighting [maximum for which case is wired] (1.48 for six shelves); then add together [0.48 + 1.48 = 1.96 amps for 120V] (for 230V, multiply 1.96 \* 0.52 = 1.02).

### Line Sizing — Refer to store legend.

Hussmann Line Sizing Charts are engineered for use with Hussmann refrigeration equipment.

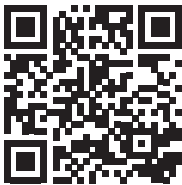

Scan the QR code with your mobile device to access additional product information or order parts.

Parts may also be ordered at:

**parts.hussmann.com**

**Call toll free: 1.855.487.7778**

## Revision History

Revision A: December 2016: Original Issue

Revision B: January 2017: Updated cross section.

Revision C: April 2017: Updated LED energy values.

Revision D: April 2017: Updated LED energy values.

Revision E: September 2017: Updated notes page. Other changes marked with a bar, circle or underline.

Revision F: July 2019: Updated parts list, lighting and CaseShieldPTM.

Revision G: December 2023: Updated fan and lighting information. Updated wiring diagrams.