

Item No. \_\_\_\_\_



## FS-OT-1718-24A

Countertop, Self-Contained,  
Self-Service Merchandiser

### Advantages

- Ideal for impulse, POS locations
- Open front allows unobstructed product access
- Low noise
- Floor drain not required
- Performs to NSF TYPE II environments

### Key Features

- Full access rear loading door
- Adjustable shelf
- All black interior and exterior
- Canopy LED light
- Energy efficient night curtain
- View end panels
- Removable leveler legs

### Options

- All stainless-steel interior and exterior
- Magnetic, removable sign holder



*Shown with removable leveler legs*



## Hussmann Corporation

12999 St. Charles Rock Rd.  
Bridgeton, MO 63044-2483  
Ph: 800.592.2060

[www.hussmann.com](http://www.hussmann.com)

# FS-OT-1718-24A

Countertop, Self-Contained, Self-Service Merchandiser

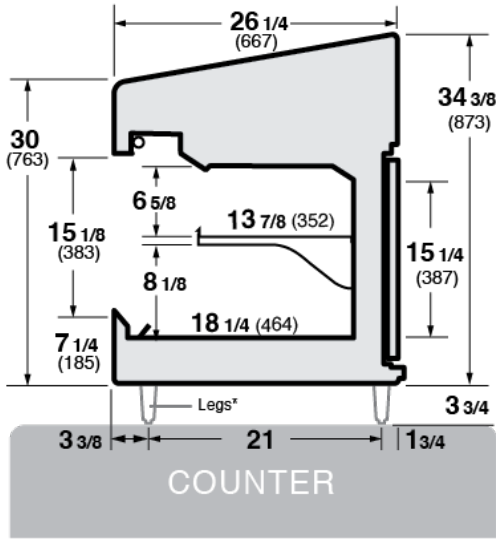

Cross Section

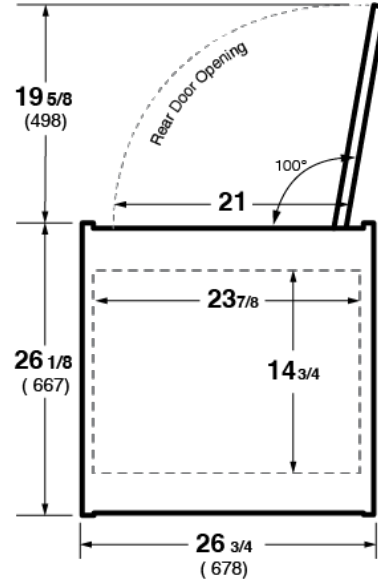

Plan View

AIA #

Model	Shelves	L	D	H w/legs*	Disc. Air	Intake Exhaust	Ref.	Volts	Run Amps	Noise	Cord Length	Weight	Enviro- ment
<b>FS-OT-1718-24A</b>	1	26.75 (678)	26.25" (667)	34.38" 38.25"	30°-35°F	Upper Rear Top	R290A	115	6.21	66 db	10'	165 lb (75 kg)	NSF Type II

\*Note: 3.75" legs shipped detached, (case can sit on counter without)

Notes:

NEMA 5-15P



[DATA SHEET](#)

For more information scan or click above.

We reserve the right to change or revise specifications and product design in connection with any feature of our products. Such changes do not entitle the buyer to corresponding changes, improvements, additions, or replacements for equipment previously sold or shipped. For additional resources, contact your representative or visit [www.hussmann.com](http://www.hussmann.com).

**HUSSMANN**<sup>®</sup>  
FOOD SERVICE

12999 St. Charles Rock Rd.  
Bridgeton, MO 63044-2483  
Ph: 800.592.2060  
[www.hussmann.com](http://www.hussmann.com)