

Parallel Rack System & CO₂ Cascade

Medium and Low Temperature



IMPORTANT

Keep in store for future reference!

CO₂ CASCADE

Installation & Operation Manual

P/N 3151784_C

October 2025



BEFORE YOU BEGIN

Read these instructions completely and carefully.



The precautions and use of the procedures described herein are intended to use the product correctly and safely. Comply with the precautions described below to protect you and others from harm. Relative to their potential danger, the relevant matters are divided into four parts as defined by ANSI Z535.5

ANSI Z535.5 DEFINITIONS



• **DANGER** – Indicate[s] a hazardous situation which, if not avoided, will result in death or serious injury.



• **WARNING** – Indicate[s] a hazardous situation which, if not avoided, could result in death or serious injury.



• **CAUTION** – Indicate[s] a hazardous situation which, if not avoided, could result in minor or moderate injury.

• **NOTICE** – *Not related to personal injury* – Indicates[s] situations, which if not avoided, could result in damage to equipment.

Environmental Concerns

Hussmann recommends responsible handling of refrigerants that contain Chlorine, Fluorine and Carbon (CFCs) and those that contain Hydrogen, Chlorine, Fluorine, and Carbon (HCFCs). Only certified technicians may handle these refrigerants. All technicians must be aware and follow the requirements set forth by the Federal Clean Air Act (Section 608) for any service procedure being performed on this equipment that involves refrigerant. Additionally, some states have other requirements that must be adhered to for responsible management of refrigerants.



WARNING

PERSONAL PROTECTION EQUIPMENT (PPE)

Only qualified personnel should install and service this equipment. Personal Protection Equipment (PPE) is required whenever servicing this equipment. Wear safety glasses, gloves, protective boots or shoes, long pants, and a long-sleeve shirt as required when working with this equipment. Observe all precautions on tags, stickers, labels and literature attached to this equipment.



CAUTION

Contractors shall strictly adhere to specifications provided by the Engineer of Record (EOR), as well as US Environmental Protection Agency regulations, OSHA regulations, and all other federal, state and local codes. This work should only be done by qualified, licensed contractors. There are numerous hazards, not limited to, but including: burns due to high temperatures, high pressures, toxic substances, electrical arcs and shocks, very heavy equipment with specific lift points and structural constraints, food and product damage or contamination, public safety, noise, and possible environmental damage. Never leave operating compressors unattended during the manual soft-start process. Always power rocker switches off when unattended.



This warning does not mean that Hussmann products will cause cancer or reproductive harm, or is in violation of any product-safety standards or requirements. As clarified by the California State government, Proposition 65 can be considered more of a 'right to know' law than a pure product safety law. When used as designed, Hussmann believes that our products are not harmful. We provide the Proposition 65 warning to stay in compliance with California State law. It is your responsibility to provide accurate Proposition 65 warning labels to your customers when necessary. For more information on Proposition 65, please visit the California State government website.

WARNING

— LOCK OUT / TAG OUT —

To avoid serious injury or death from electrical shock, always disconnect the electrical power at the main disconnect when servicing or replacing any electrical component. This includes, but is not limited to, such items as controllers, electrical panels, condensers, lights, fans, and heaters.



...ATTENTION
INSTALLER

**It is the installing contractor's
responsibility to consult local agencies
for local code requirements.**

CAUTION

This manual was written in accordance with originally prescribed equipment that is subject to change. Hussmann reserves the right to change all or part of the equipment for future stores such as, but not limited to, controllers, valves and electrical specifications. It is the installers responsibility to reference the refrigeration drawings supplied for each installation, as directed by the Engineer of Record.

WARNING

This equipment is prohibited from use in California with any refrigerants on the "List of Prohibited Substances" for that specific end-use, per California Code of Regulations, Title 17, Section 95374.

Use in other locations is limited to refrigerants permitted by country, state, or local laws and is the responsibility of the installer/end-user to ensure only permitted refrigerants are used.

This disclosure statement has been reviewed and approved by Hussmann and Hussmann attests, under penalty of perjury, that these statements are true and accurate.

WARNING

Proper Field Wiring and Grounding Required!
Failure to follow code could result in death or serious injury. All field wiring **MUST** be performed by qualified personnel. Improperly installed and grounded field wiring poses **FIRE** and **ELECTROCUTION** hazards. To avoid these hazards, you **MUST** follow requirements for field wiring installation and grounding as described in NEC and your local/state electrical codes.

GENERAL SAFETY GUIDANCE FOR CO₂ SYSTEMS

CO₂ systems have similar safety concerns with all other refrigerants, in that it displaces oxygen and is heavier than air and will concentrate closer to the floor if there is a system leak. CO₂ should be monitored for leaks similar to other refrigerants. Confirm operation of leak detectors (all refrigerants used), audible / visible alarms and machine room ventilation.

Also, CO₂ Cascade type receivers are normally kept at +25°F. If the temperature of the receiver reaches 43°F, CO₂ will start to vent from the regulating relief valve (set at 585 psi). This would typically only happen during a long power outage or a power outage of the back-up condensing unit.

CO₂ relief valves should never have piping added to the outlets. Dry ice will form whenever a relief valve vents, and if outlet piping is added, this dry ice will restrict or possibly block the flow. Outdoor systems typically have all relief valves factory mounted on the equipment and indoor systems will have the relief valve assemblies installed in the field. Additional information on the safe use and handling of carbon dioxide can be found in Standards from the Compressed Gas Association Standard <https://www.cganet.com/>.

ASPHYXIATION

R744 is odorless, heavier than air and is an asphyxiate. The practical limit¹ of R744 is lower than HFCs because of its potential for high toxicity (HFCs are non toxic):

- Practical limit of R744, 0.006 lb/ft³ (56,000 ppm);
- Practical limit of R404A, 0.030 lb/ft³ (120,000 ppm)

Note – The practical limit is defined in ASHRAE 34 but may vary depending on regional regulations. The table below summarises the effect of CO₂ at various concentrations in air.

PPM of CO ₂	Effects
370	Concentration in atmosphere
5,000	Long-term exposure limit (8 hours)
15,000	Short-term exposure limit (10 min)
30,000	Discomfort, breathing difficulties, headache, dizziness, etc.
100,000	Loss of consciousness, death
300,000	Quick death

If a leak of R744 could result in a concentration exceeding the practical limit in an enclosed occupied space such as a cold room, precautions must be taken to prevent asphyxiation. These include the use of permanent leak detection which activates an alarm in the event of a leak.

IMPORTANT
KEEP IN STORE FOR FUTURE REFERENCE
Quality that sets industry standards!

12999 St. Charles Rock Road • Bridgeton, MO 63044-2483

U.S. & Canada 1-800-922-1919 • Mexico 01-800-890-2900

www.hussmann.com

© 2025 Hussmann Corporation

TABLE OF CONTENTS

SAFETY

Before you Begin	iii
Safety Definitions	iii
Environmental Concerns	iii
Cautions and Warnings	iii
General Safety and Guidance for CO ₂ Systems	iv
Asphyxiation	iv

CO₂ CASCADE SYSTEM OVERVIEW

Introduction to CO ₂ Cascade	1-1
CO ₂ Quality	1-1
CO ₂ Cascade Diagrams	1-2
System Overview	1-4
System Inspection	1-4
Legends & General Piping Diagrams	1-5
Typical CO ₂ Cascade Piping	1-6

SYSTEM INSTALLATION

Machine Room Requirements	2-1
Handling	2-1
Rack Unit Placement	2-2
Floor Drain	2-3
Remote Condenser Placement	2-3
Installing Vibration Pads	2-4

COMPONENT PIPING & LINE SIZING

Copper Tube and Fittings	3-1
Insulation	3-1
Rack Piping Overview	3-2
Refrigeration Line Runs	3-2
Parallel Rack Insulation	3-4
Special Piping for Open Rooms	3-4
Connecting Parallel 3-Way Valves	3-4
Run Lengths and Equivalent Feet	3-4
Rack to Condenser Piping	3-4
Purge Valve Location	3-4
Receiver Safety Relief Valve	3-4
Connecting to two Manifolds	3-4
Equalizing Line	3-5
Rack to Heat Reclaim	3-5
Rack to Remote Header	3-5
Offset and Expansion Loop Construction	3-7
Branch Line Piping	3-8
Koolgas Defrost	3-9

EQUIPMENT STARTUP PROCEDURES

General Rack Components	4-1
Control Settings General Description	4-1
Setup Sheet	4-2
Leak Testing	4-4
Leak Testing CO ₂	4-4
Parallel Rack Evacuation / Charging	4-5
Pre-Charge Check List (CO ₂)	4-7
Charging Procedure for HFO/HFC or CO ₂	4-7
Control Checks	4-8
Parallel Rack Startup Procedure	4-8
Adjusting the Holdback Valve A9	4-9
Adjusting the A8 Valve	4-10
Setting the Condenser Flooding Valve (Hot Weather)	4-11
Winterizing Setup	4-12
Parallel Rack Startup Sequence	4-13
Startup Procedure HFC/HFO or CO ₂	4-14
After Startup	4-15
Setting Expansion Valve Superheat	4-16
Component Testing	4-17
Y825 Valve Adjustment	4-18
Liquid Line Differential Valve Adjustment	4-18
Evaporator Pressure Regulator Adjustment	4-19
Low Pressure Controls	4-19
High Pressure Control Adjustment	4-20
Commissioning Sign-Off Sheet	4-21

SEQUENCE OF OPERATION & COMPONENT OVERVIEW

General Overview of Sequence	5-1
System Inputs and Controls	5-1
Compressors	5-2
Condenser Control	5-3
Desuperheater Control Strategy	5-3
Subcooling	5-4
Liquid Surge	5-4
Two-Stage Mechanical Subcooling	5-5
Rack Refrigerant Flow	5-5
Heat Reclaim Cycle	5-6
Oil System Cycle	5-6
Component Overview	5-7
EPR Valve Operation	5-7
Main Liquid Line Solenoid Valves	5-8
Branch Liquid Line Solenoid Valves	5-8
3-Way Split Condensing Valves	5-9
Surge Receiver Valves	5-9
Heat Reclaim Valve	5-10
Thermostatic Expansion Valve (TEV)	5-10
Flooding Valve &	
Receiver Pressure Regulating Valve	5-10
Oil Pressure Regulation Valve	5-11
Pressure Regulating Relief Valve	5-11
Control Panel	5-12
Oil Level Regulators	5-12
Sporlan Oil Level Control OL-1 Series	5-12
Liquid/Suction Heat Exchanger (Optional Med Temp)	5-12
Emergency Back-up Systems	5-13
Field-Installed Valves	5-13
Glossary of Terms	5-14

ELECTRICAL INFORMATION

Electrical Overview	6-1
Field Wiring	6-1
Required Field Wire Size	6-1
Merchandiser Electrical Data	6-2
Merchandiser Field Wiring	6-2
Electrical Connections	6-2
Identification of Wiring	6-2
Electrical Diagrams	6-3
Component Wiring Guidelines	6-3
Compressor Control	6-3
Electronic Controller	6-4
Time Delay	6-4
Pressure Switches	6-4
Switchback Control	6-4
Crankcase Heaters	6-4
Oil Failure Relay	6-4
Current Relay	6-4
Defrost Controls	6-5
Temperature Controls	6-5
Alarm Control	6-6
Inverter Control	6-6

TECHNICAL SUPPORT & COMPONENT REFERENCE

DOCUMENTS	7-1
-----------	-----

MAINTENANCE & SERVICE

Oil Changes	8-1
Temprite Installation for Oil Separators	8-2
Compressor Replacement	8-3
Winter Condensing Pressure Controls	8-4
General Maintenance	8-4
Drier & Filter Cores Replacement	8-5

WARRANTY	8-6
----------	-----

CO₂ CASCADE SYSTEM OVERVIEW

INTRODUCTION TO CO₂ CASCADE

This manual provides general information that covers the installation, startup, maintenance and service of centralized low temperature cascade systems using carbon dioxide (CO₂). The primary refrigerant and components can vary depending on customer requirements. For detailed information regarding a specific component or application use the QR codes in this manual or contact your Hussmann representative.

Additional specifications for job-specific site installation may include:

- Legend of Equipment Load and Electrical Requirements
- Site-Specific Sequence of Operations
- Specifications of Components
- Piping Diagrams
- Site-Specific Dimension and Lifting Requirements
- Equipment Overview and List of Options

CO₂ QUALITY

Carbon dioxide that is purchased for use in secondary refrigeration systems should be of a purity level high enough to prevent accumulation of non-condensable gases and moisture in the condenser-evaporator. A build up of these gases can block heat transfer causing reduced operation or inoperation of the system.

CO₂ is commercially available at several different purity levels. The common names and percent purity are listed below. Hussmann recommends using Refrigeration Grade (99.99% purity) CO₂.

Grade	Purity
Industrial Grade	99.5%
Bone Dry (minimum acceptable)	99.8%
Anaerobic Grade	99.9%
Refrigeration Grade (Hussmann recommended)	99.99%
Coleman (Instrument) Grade	99.99%
Research Grade	99.999%
Ultra-Pure Grade	99.9999%

***Medical grade CO₂ should not be used, due to the outlet pressure regulators typically present on tanks.**

*The use of Bone-Dry grade is the minimum acceptable purity to ensure proper operation of the equipment and is pure enough to prevent accumulation of non-condensable gases in the system.

Mixing of higher purity grades of CO₂ is acceptable. Lower grades of CO₂ contain higher levels of contaminants & water and may decrease system performance. Higher levels of moisture may react with the CO₂ and form carboxylic acid that can degrade component integrity. Hussmann recommends keeping enough refrigeration grade CO₂ onsite to charge the system.

One of the benefits of CO₂ compared to synthetics is a high vapor density. CO₂ for low temp is approximately 5 times more dense, and this translates into smaller suction pipe sizes than other synthetic refrigerants.

1-2 CO2 CASCADE SYSTEM OVERVIEW

CO2 CASCADE DIAGRAMS

CO₂ has found use in the supermarket industry in a wide variety of system layouts. Below and on the following page are example diagrams of a CO₂ Cascade or (secondary system).

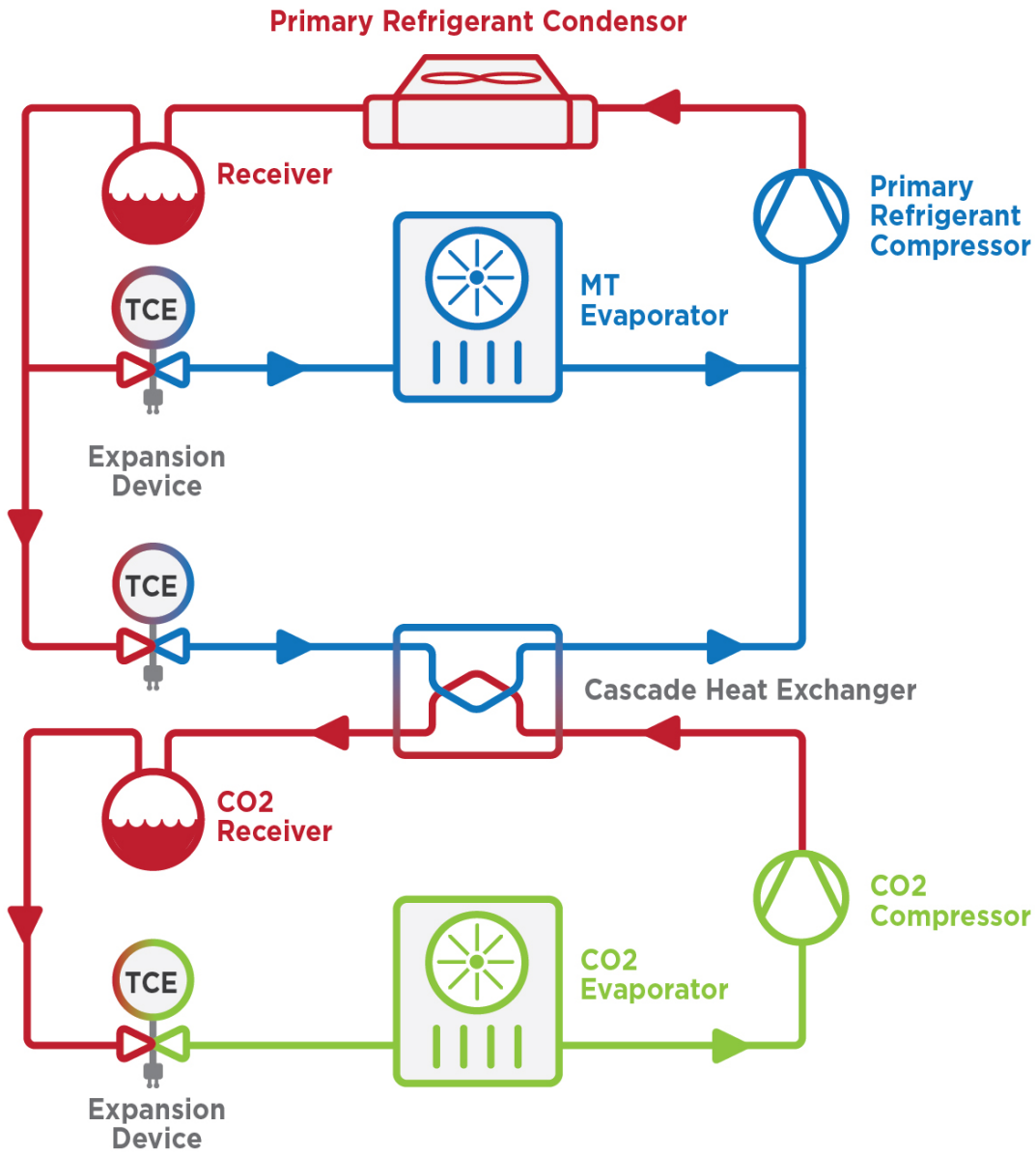

TYPICAL CO₂ Hybrid Cascade System

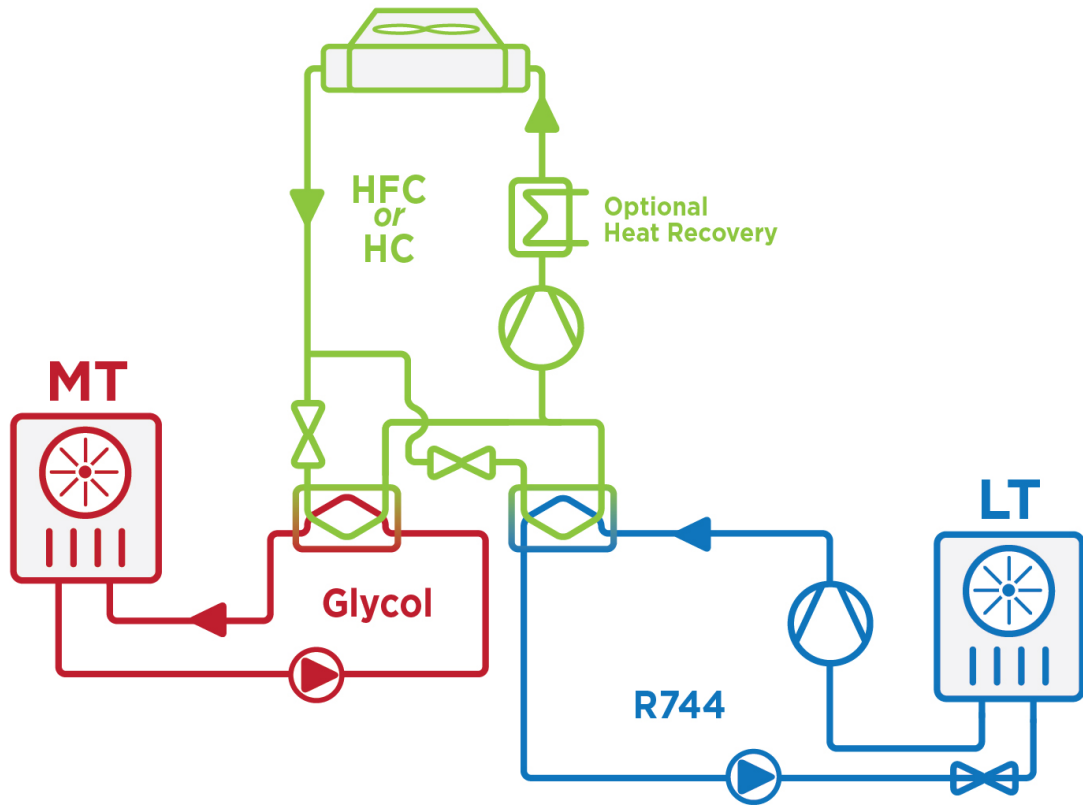

Indirect Cascade Refrigeration System - 744 + Glycol

(This diagram is for illustrative purposes only. This manual does not cover this type of system.)

SYSTEM OVERVIEW

This refrigeration systems use naturally occurring, environmentally friendly, and energy efficient CO₂ that is compliant with federal environmental regulations.

This Cascade CO₂ equipment is designed with a “high side” parallel rack, operating with a standard, synthetic refrigerant (450 psi max. pressure). The high side handles all Medium Temp. (MT) loads for the store as well as the CO₂ condensing load. The “low side” uses CO₂ (R-744) as the refrigerant for the Low Temp. (LT) loads (650 psi max. pressure). Liquid CO₂ is sent to the freezers and low temp cases, similar to synthetic refrigerants, however, there are some basic differences and requirements that need to be followed for commissioning.

One main thing to remember is the MT part of the system needs to be running before charging or running the CO₂ (LT) system. Another main difference is that the CO₂ discharge is typically cooled by a de-superheater and this is important to protect the main plate heat exchangers as well as to reduce energy.

SYSTEM INSPECTION

Upon delivery of the unit(s), verify that the correct unit and equipment is received by comparing the information on the unit serial plate with the ordering and submittal documents. All equipment should be thoroughly examined for shipping damage before and during unloading. This equipment has been carefully inspected at our factory. Any claim for loss or damage must be made to the carrier. The carrier will provide any necessary inspection reports and/or claim forms.

There are some optional features that might be included on the equipment:

- **Suction EPRs for the cascade high side**

Suction EPRs can minimize any expansion valve hunting by keeping a constant evaporator pressure. These will, of course, cause a slight pressure drop for the high side suction.

- **Liquid-suction heat exchangers for the cascade high side**

These might not be included, especially if the high side already has subcooling.

- **Auxiliary heat exchanger and back-up condensing unit**

The main reason is to use with a generator to allow the CO₂ receiver to be kept cool if there is a power outage. If this is included, an exercise cycle is recommended. Further, the recommended strategy includes turning on if the receiver pressure / temperature rises for any reason (as a help to the high side).

NOTE:

In addition to the legend, each rack has specific setpoints.

LEGEND, LABELS & WIRING DIAGRAMS

Each parallel rack is shipped with a detailed legend that identifies the specialized components used such as compressors, valves, oil separators, etc. The legend details, BTUH loads, control valves, circuit information and suction temperatures. The type of refrigerant and lubricant to be used are prominently displayed on the front of the rack. All racks include complete wiring diagrams (control, primary power, board and point layout.) All wiring is color coded.

PARALLEL RACK NOMENCLATURE CHART

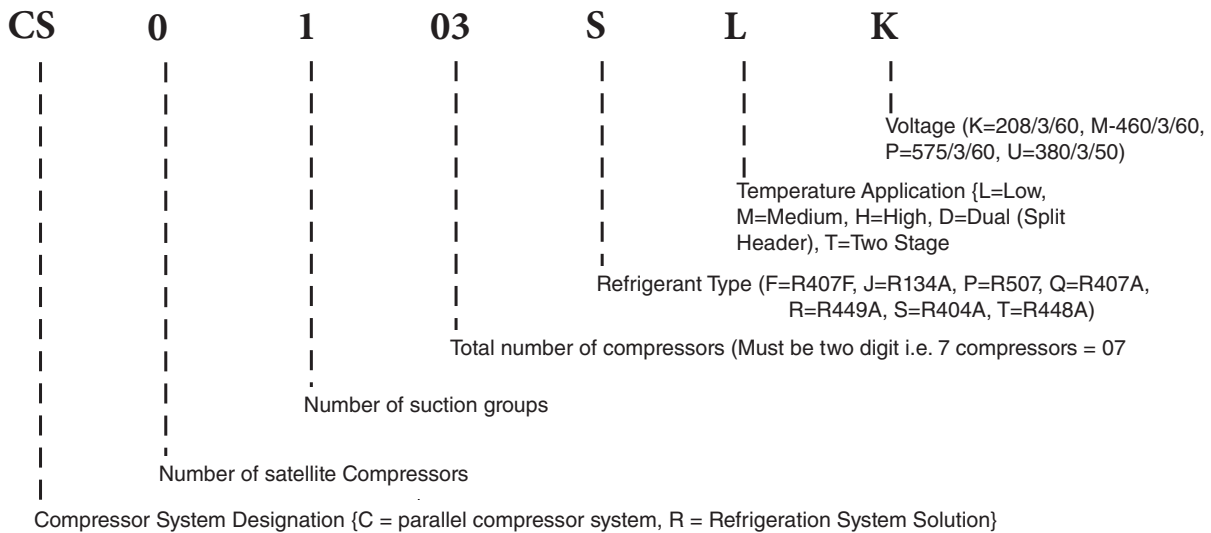

CO₂ NOMENCLATURE CHART

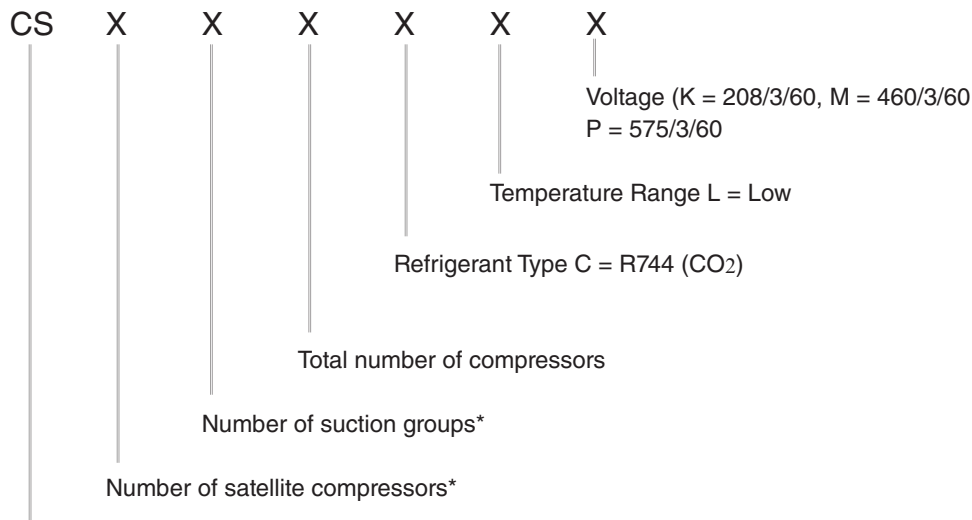

CS – Product family designation (Custom System)

* Contact Hussmann Design Engineering for additional information

TYPICAL CO2 CASCADE PIPING (See following page for right side of diagram.)

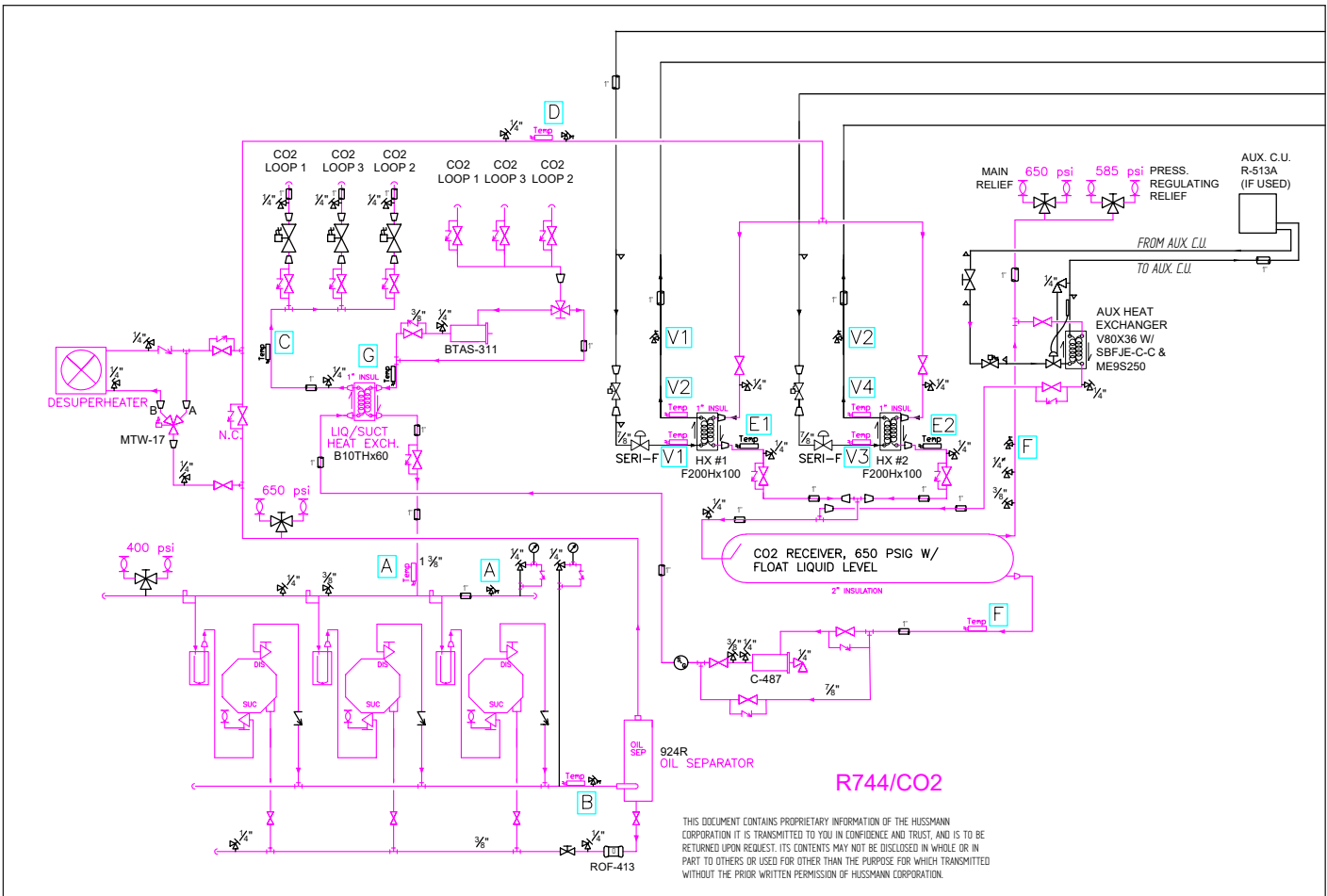

Temp Probe Labels

- A. CO2 Suction Temp. at Header
- B. CO2 Discharge Header Temperature
- C. CO2 Liquid Temperature After LSHX
- D. CO2 Discharge Temperature after Desuperheater
- E1. CO2 Liquid After HX #1
- E2. CO2 Liquid After HX #2
- F. CO2 Liquid Temp. before LSHX
- G. CO2 Suction Loop Temp.
- H. Omitted
- U1. R513A Subcooler Liquid Temperature Post EEV
- U2. R513A Subcooler Suction Temp.
- V1. R513A HX #1 Inlet Temp.
- V2. R513A HX #1 Outlet Temp.
- V3. R513A HX #2 Inlet Temp.
- V4. R513A HX #2 Outlet Temp.
- W. R513A Suction Temp.
- X. R513A Dischrg Header Temp.
- Y1. R513A Liquid Subcooler Inlet Temp.
- Y2. R513A Liquid Subcooler Outlet Temp.
- Z. R513A Liquid Drain Temp.

Transducer Labels

- A. CO2 Suction Header Pressure (500#)
- B. CO2 Discharge Header Pressure (1000#)
- C. Omitted
- D. CO2 Discharge Pressure after Desuperheater (1000#)
- F. CO2 Receiver Pressure (1000#)
- U. R513A Subcooler Suction Pressure (200#)
- V1. R513A HX #1 Suction Pressure (200#)
- V2. R513A HX #2 Suction Pressure (200#)
- W. R513A Suction Pressure (200#)
- X. R513A Discharge Header Pressure (500#)
- Y. R513A Discharge Pressure after Oil Separator (500#)
- Z. R513A Liquid Drain Pressure (500#)

TYPICAL CO2 CASCADE PIPING

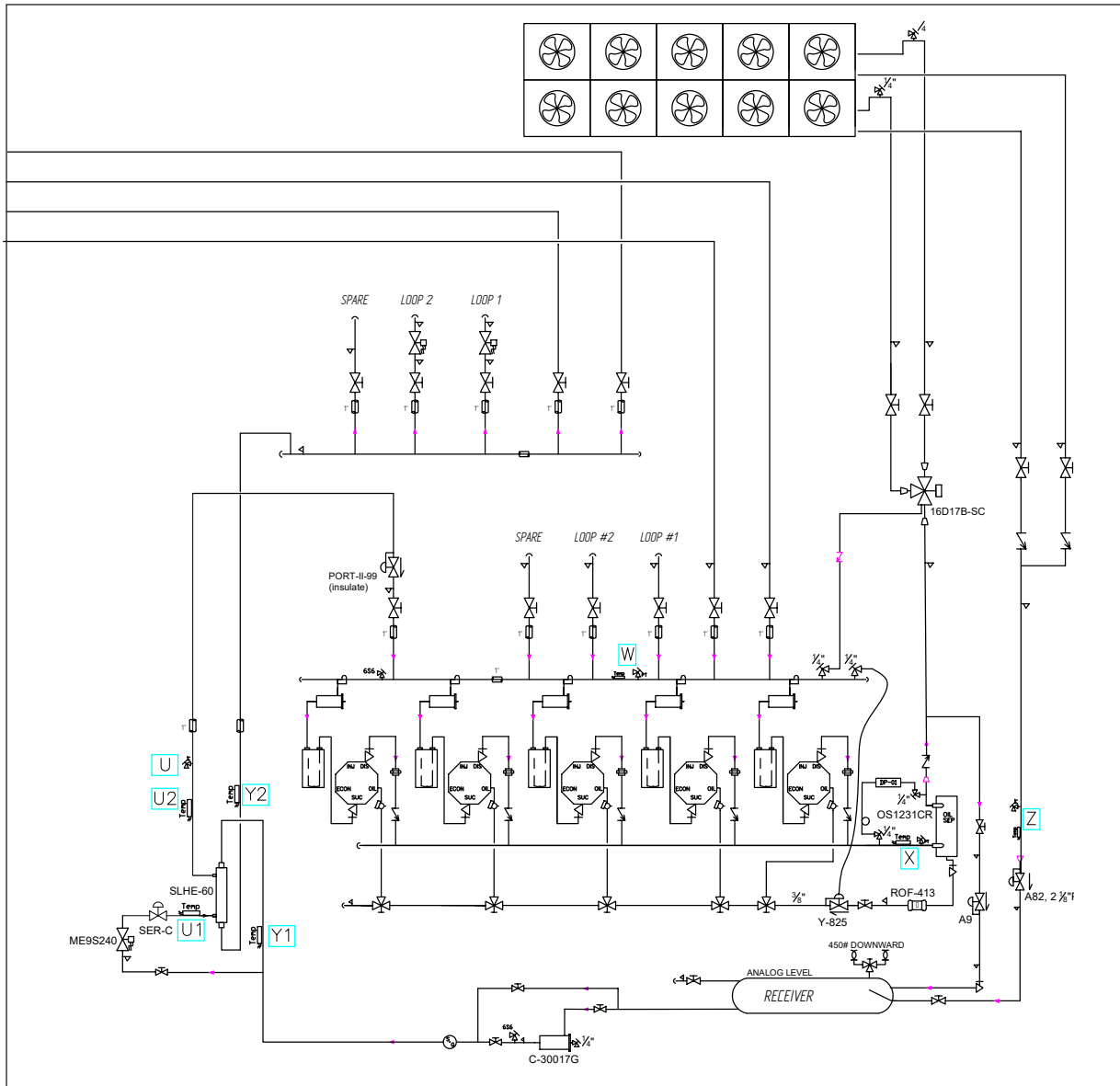

Temp Probe Labels

- A. CO2 Suction Temp. at Header
- B. CO2 Discharge Header Temperature
- C. CO2 Liquid Temperature After LSHX
- D. CO2 Discharge Temperature after Desuperheater
- E1. CO2 Liquid After HX #1
- E2. CO2 Liquid After HX #2
- F. CO2 Liquid Temp. before LSHX
- G. CO2 Suction Loop Temp.
- H. Omitted
- U1. R513A Subcooler Liquid Temperature Post EEV
- U2. R513A Subcooler Suction Temp.
- V1. R513A HX #1 Inlet Temp.
- V2. R513A HX #1 Outlet Temp.
- V3. R513A HX #2 Inlet Temp.
- V4. R513A HX #2 Outlet Temp.
- W. R513A Suction Temp.
- X. R513A Discharge Header Temp.
- Y1. R513A Liquid Subcooler Inlet Temp.
- Y2. R513A Liquid Subcooler Outlet Temp.
- Z. R513A Liquid Drain Temp.

Transducer Labels

- A. CO2 Suction Header Pressure (500#)
- B. CO2 Discharge Header Pressure (1000#)
- C. Omitted
- D. CO2 Discharge Pressure after Desuperheater (1000#)
- F. CO2 Receiver Pressure (1000#)
- U. R513A Subcooler Suction Pressure (200#)
- V1. R513A HX #1 Suction Pressure (200#)
- V2. R513A HX #2 Suction Pressure (200#)
- W. R513A Suction Pressure (200#)
- X. R513A Discharge Header Pressure (500#)
- Y. R513A Discharge Pressure after Oil Separator (500#)
- Z. R513A Liquid Drain Pressure (500#)

1-8 CO2 CASCADE SYSTEM OVERVIEW

NOTES:

SYSTEM INSTALLATION

MACHINE ROOM REQUIREMENTS

Equipment must be located in a dedicated operating area to provide enough working space for service personnel and meet electrical codes.

Hussmann recommends ventilation should be a minimum of 65 cfm per compressor unit horse power. The air inlet should be sized for a maximum of 500 fpm velocity. Ventilation fans should cycle by thermostatic control.

Proper ventilation provides needed air flow across the compressors that helps maintain the operation of the rack. Duct work may be necessary. All ventilation equipment is field-supplied and installed. **Check national and local codes for ventilation requirements before installation.** The equipment room floor must solidly support the compressor unit as a live load. Ground level installation seldom presents problems, but a mezzanine installation must be carefully engineered.

A concrete base must be built on the mezzanine floor to keep mechanical vibrations and noise to an acceptable level.

NOTE:

Recommended spacing is site specific. It is the installer's responsibility to check local codes and standards.

HANDLING

Each compressor rack has lower base frame brackets for rigging and lifting. It is important to use the spreader bar to prevent the rigging from damaging the rack. Before placing the rack in the machine room, remove the shipping skid. For units with vertical receivers, be aware of the level sensor on top of the receiver. Lifting cables and other equipment must not come in contact with any unit piping or electrical components.

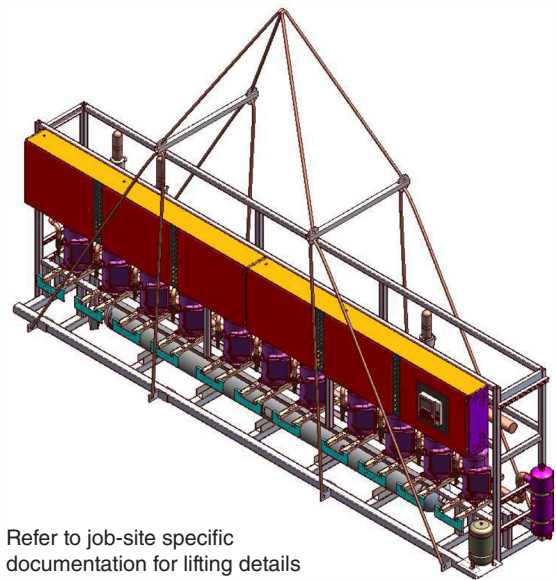

Refer to job-site specific documentation for lifting details

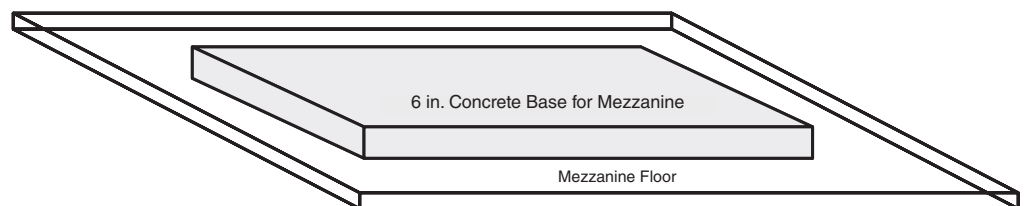
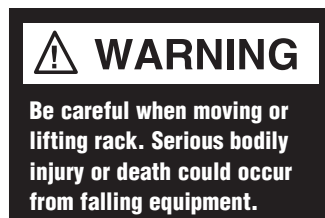

2-2 SYSTEM INSTALLATION

RACK UNIT PLACEMENT

Observe the minimum and maximum distances as described below for setting the rack in relation to other refrigeration equipment:

Minimum Allowable Distances

Water-cooled Condenser:

The minimum allowable elevation is one foot from the outlet to the receiver inlet.

Air-cooled Condenser:

The minimum allowable distance is 4 1/2 ft with no flooding valve from the mounting surface of the air-cooled condenser to the mounting surface of the custom rack.

The minimum allowable distance is 6 feet with a flooding valve from the mounting surface of the air-cooled condenser to the center of the flooding valve.

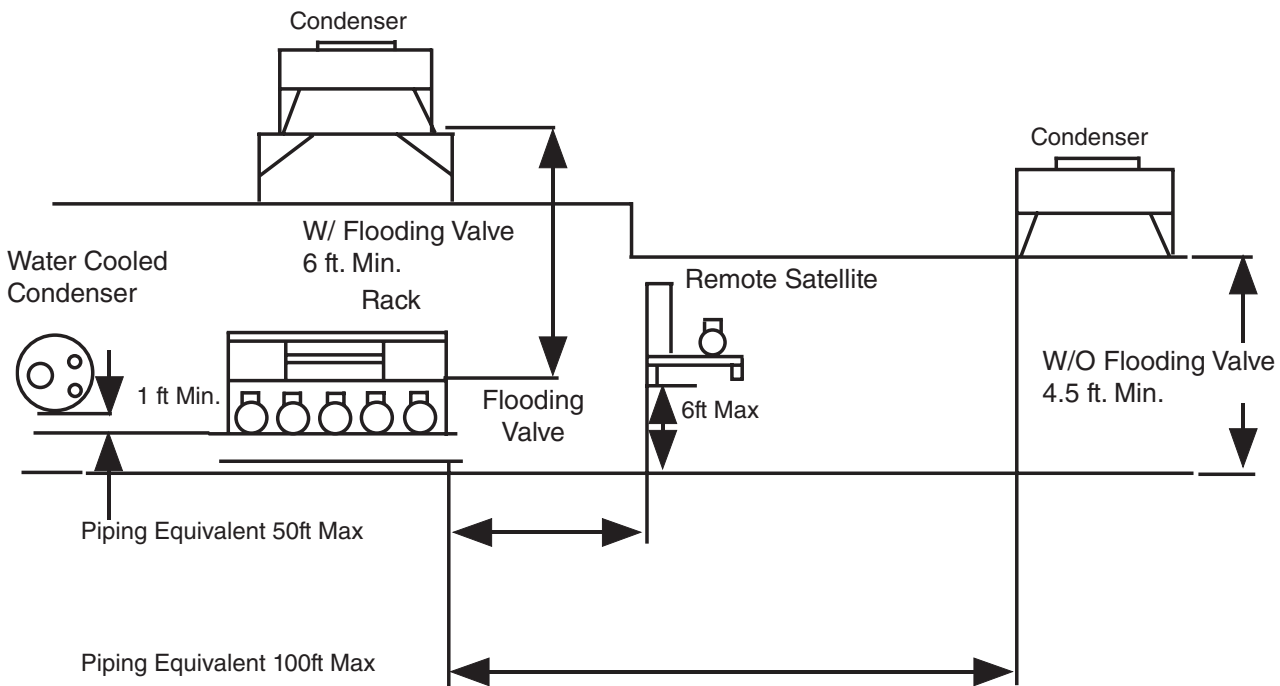

FLOOR DRAIN

Provide a floor drain for disposal of condensate that may form on the compressor unit or header defrost assembly.

REMOTE CONDENSER PLACEMENT

Locate the condenser with at least three feet of clearance on all sides to provide adequate air circulation if not otherwise specified by the condenser manufacturer. If roof mounted, place on column-supported beams or load-bearing walls. The mounting surface for the condenser should be at least six feet higher than the rack flooding valve. When a flooding valve is not used, the minimum distance from the base of the rack to the mounting surface of the condenser is 4.5 ft. If a Krack Microchannel (MX) is used, sufficient room on the right side of the unit must be available to remove the micro channel slabs. At least nine feet of clearance must be available.

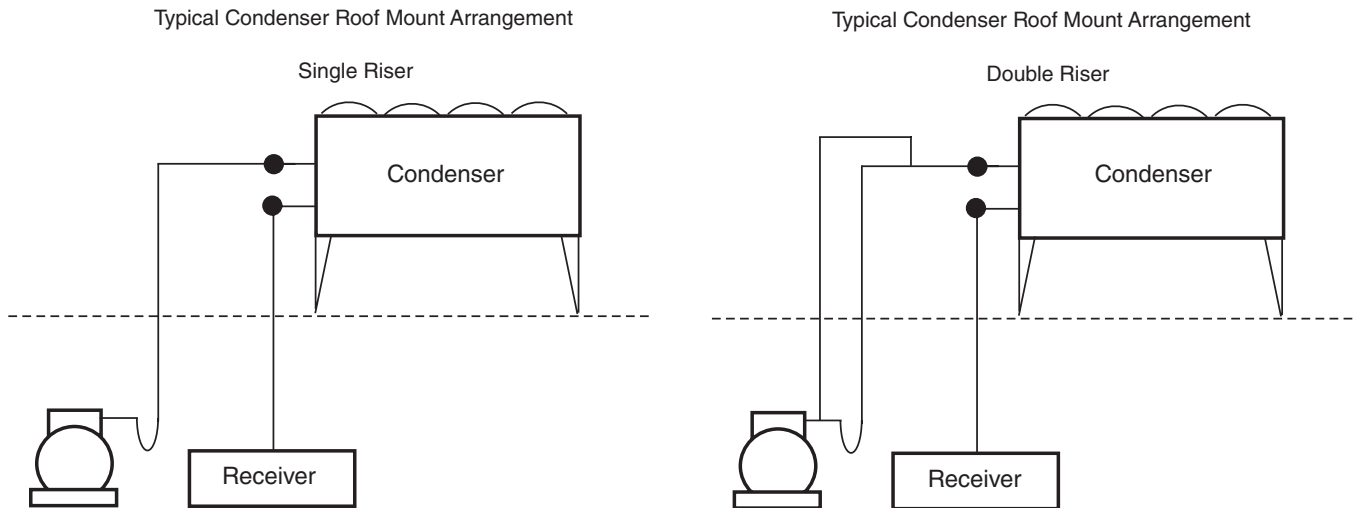

2-4 SYSTEM INSTALLATION

INSTALLING VIBRATION PADS

Each rack must be located in the machine room so that it is accessible from all sides. A minimum of 36 in. clearance is recommended to provide easy access to components. Vibration isolation pads are supplied with each rack. The entire weight of the rack must rest on these pads. The pads should be located as shown in the image below. Cross-level the compressor unit so all compressors are level with each other. To ensure both proper leveling and vibration isolation, perform the following:

Vibration Pad Quantities
3 in. x 3 in. x 2 in.

# of compressors per pack	Reciprocating or Scroll	Screw Compressor
2 Compressors	4 Each	6 Each
3 Compressors	4 Each	6 Each
4 Compressors	6 Each	8 Each
5 Compressors	6 Each	8 Each
6 Compressors	6 Each	8 Each*
7 Compressors	8 Each	-----
8 Compressors	8 Each	-----
9 Compressors	8 Each	-----
10 Compressors	10 Each	-----

***10 for Bitzer and Vertical Receiver**

1. Lift the rack in accordance with procedures on the following pages.
2. Place minimum 15 gauge 3 in. by 3 in. galvanized or stainless steel shims to compensate for uneven floors. (Shims must be field supplied.)
3. Place vibration isolation pads on top of shims. See vibration pad quantities in the table at right to determine the number of pads to be used.
4. Pads should be placed over structural joist members when rack is placed on sub-floor.

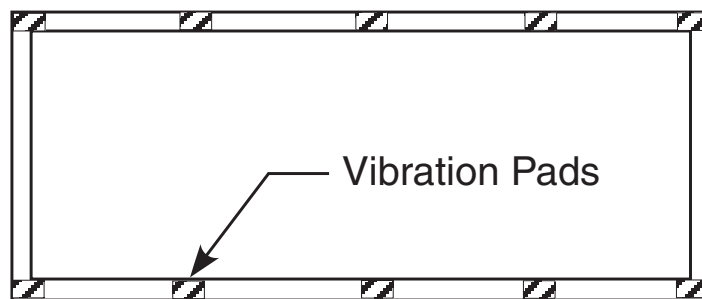

COMPONENT PIPING & LINE SIZING

COPPER TUBE AND FITTINGS

All CO₂ Liquid and Discharge lines have a maximum design pressure of 650 psi. These lines must be run with Type K copper, 5/8" to 1-1/8" (any brand), and 1-3/8" to 2-5/8" Type K, Mueller only. Further all copper tees and fittings are to be either Mueller only or may be Elkhart (EPC) for certain fittings. These are typical refrigeration fittings manufactured to ASTM B75 and B251.

All CO₂ Suction lines have a maximum design pressure of 400 psi. These lines must be run with Type L copper up to 1-5/8" lines, and Type K for 2-1/8" lines (any brand). Any standard type fittings may be used (ASTM B75 and B251).

Additional industry practices still apply:

Brazed joints should be made with standard industry practices. Use nitrogen purging, flux, and Silfoss (Hussmann recommends 15% silver content). Insulation requirements should follow job specifications. In general, the CO₂ liquid lines should be insulated with the same thickness as the suction lines. Standard tube bracing and supports are required, and standard suction practices are required (trapping and proper riser sizing).

INSULATION

Insulation should be used on CO₂ Cascade system piping to reduce the heat transfer to ambient air and to maintain subcooling in the CO₂ liquid line to the case. The insulation should be sized to allow for the worst case conditions of heating from showroom lighting and ambient temperatures. In order to minimize the required insulation thickness, install pipe in air conditioned space as much as possible. Do not size insulation for condensation prevention only. Pipe should be insulated according to local codes and customer specifications.

When installing piping that has not been pre-insulated, there are several options for insulation. Closed-cell elastomeric insulation is very popular in refrigeration applications. This type of insulation can also be used in secondary system applications. For detailed information regarding this type of insulation visit the Armaflex website at www.armacore.com.

For detailed information regarding this type of insulation visit the Dow website: <http://building.dow.com/styrofoam/na/dowpipe/library/index.htm>.

Always follow the manufacturer's recommendations for insulation thickness and proper installation.

RACK PIPING OVERVIEW

This section provides information for installing the refrigeration lines for a rack. The components are piped as completely as practical at the factory. Field piping requires only interconnection of the major components and the coolers, freezers and display cases. Piping must also be supported to minimize vibration. Pulsation of the refrigerant and compressor vibration can cause piping to vibrate. This vibration can cause line breakage and damage to components.

Use only clean, dehydrated, sealed refrigeration grade copper tubing. Use dry nitrogen at low pressure in the tubing during brazing to prevent the formation of copper oxide. All joints should be made with a 15 percent silver alloy brazing material. Use a 45 percent silver solder for dissimilar metals.



Ceiling Run with Supports

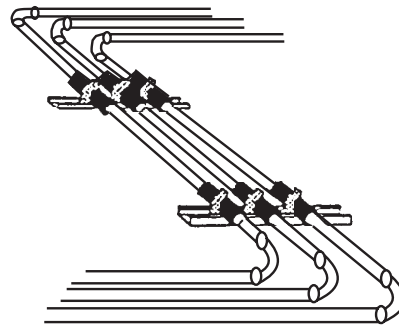

Floor Piping Run

⚠ WARNING

Always use a pressure regulator when operating nitrogen tanks.

REFRIGERATION LINE RUNS

Liquid Lines and suction lines must be free to expand and contract independently of each other. Do not clamp or solder them together. Supports must allow tubing to expand and contract freely. Do not exceed 100 feet without a change of direction or/and offset. Plan proper pitching, expansion allowance, and waterseal at the base of all suction risers. Use long radius elbows to reduce line resistance and breakage. Avoid the use of 45 degree elbows. Install service valves at several locations for ease of maintenance and reduction of service costs. These valves must be UL approved for the minimum design working pressure of the system.

Through Walls or Floors

Refrigeration lines that are run through walls or floors must have a waterseal installed, and the lines must be properly insulated. Avoid running lines through the refrigeration cases. When this is done the lines must be adequately insulated using a closed-cell elastomeric foam insulation.

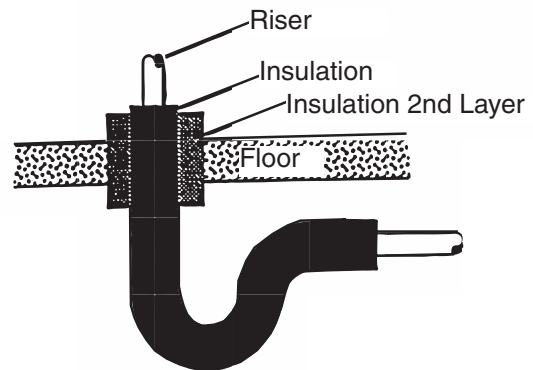

Insulating a Riser

From Machinery to Solid Object

When mounting lines from machinery to a solid object allow line freedom for vibration to prevent metal fatigue.

Don't over support piping that is in contact with the compressor racks. The machinery must not be tightly stressed from piping that does not allow for some vibration. If piping is too tight metal fatigue will occur.

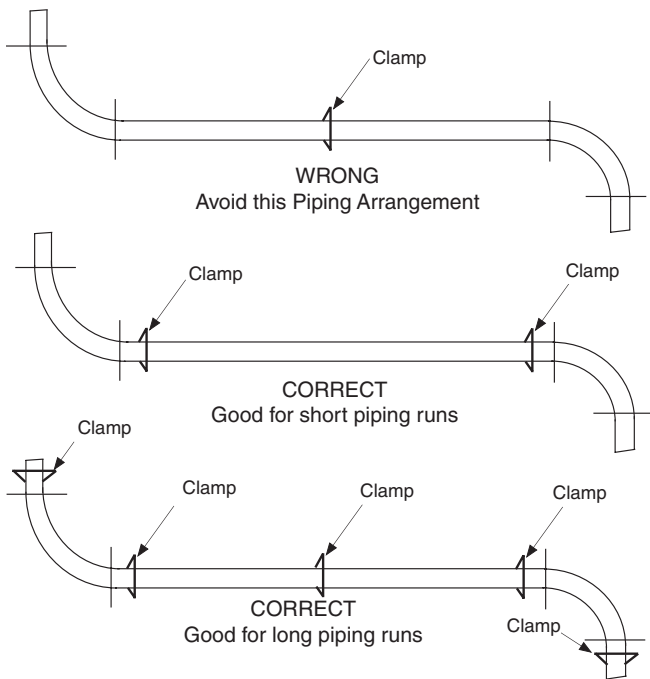

Waterseal Construction

Waterseals must be installed at the bottom of all suction risers to return oil to the compressors to avoid trapping oil.

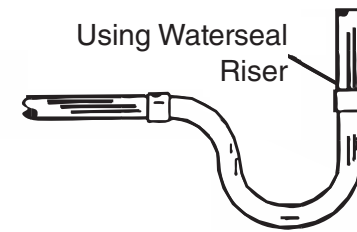
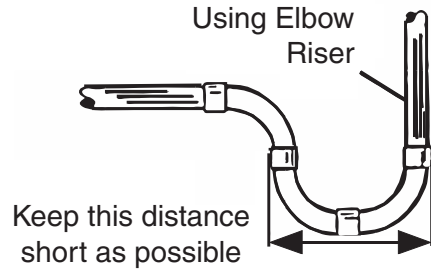

Waterseal Construction

Reduced Riser

When a reduced riser is necessary, place the reduction coupling downstream of the waterseal.

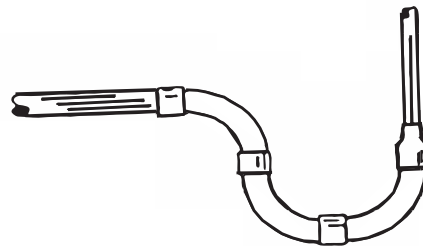

Reduces Riser

Protecting Valves and Clamps

When brazing near factory installed clamps or valves be sure to protect them with a wet rag to avoid overheating. Insulate all reduced risers.

All clamps must be properly anchored. Rubber gromets must be installed to prevent chafing of the lines.

3-4 COMPONENT PIPING & LINE SIZING

Elbows

Only use long radius elbows. Long elbows have been shown to have less pressure drop and greater strength. It is especially important to use long radius elbows to hot gas discharge lines.

Factory Supplied Stubs

Stub sizes provided from the manifolds do not automatically correspond to the line sizes necessary. It is the installer's responsibility to supply reduction couplings.

PARALLEL RACK INSULATION

All suction lines and subcooled liquid lines must be insulated. Subcooled liquid in the liquid line will warm if the lines are left unprotected, resulting in energy loss. Overtime this can lead to the liquid changing into a gas before it ever reaches the expansion valves. This is known as flashing. Flashing causes irregular flow through valves. If this occurs significant refrigerant loss and poor energy performance will occur. Compressor motors will fail if the suction line gas is too warm as it enters the compressors. For gas defrost applications, insulated suction lines help maintain temperature during defrost. Insulated lines also prevent sweating of the lines, thus eliminating drops of water on the floor below the line runs.

SPECIAL PIPING FOR OPEN ROOMS

An open food preparation room allows heat infiltration from the rest of the store at a rate which may jeopardize total refrigeration performance. To protect the rest of the refrigeration system, open preparation evaporators must be piped with a crankcase pressure regulating valve (CPR). The CPR is field installed in the suction line(s) from the evaporator(s). And the installer is responsible for proper adjustment of the valve. (See CPR Valve Section for adjustment procedures.)

CONNECTING PARALLEL 3-WAY VALVES

Due to the size limitations of 3-way valves, some of the larger Koolgas systems will require parallel connection to 2 suction stubs at the header using an offset tee construction. Do not use a bull head tee.

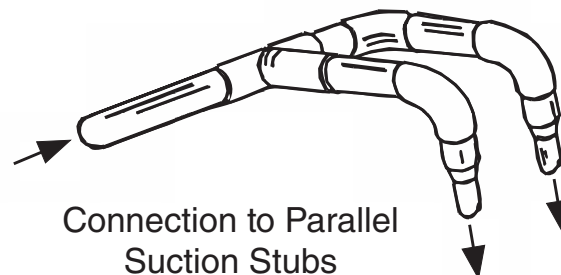

RUN LENGTHS AND EQUIVALENT FEET

When figuring run lengths, angle valves and 90 degree elbows are figured as additional straight pipe. The chart below gives equivalent lengths for these.

Equivalent Feet for Angle Valve and 90° Elbow		
Tubing Size	Angle Valve	Long Radius Elbow 90%
1/2	6	0.9
5/8	7	1.0
7/8	9	1.4
1 1/8	12	1.7
1 3/8	15	2.3
1 5/8	18	2.6
2 1/8	24	3.3
2 5/8	29	4.1
3 1/8	35	5.0
3 5/8	41	5.9
4 1/8	47	6.7

RACK TO CONDENSER PIPING

Discharge line will be routed directly to the condenser inlet stub with a purge valve at the highest point. Liquid return line will be pitched downstream, and purge valve location will provide trap-less drainage to the rack.

PURGE VALVE LOCATION

The purge valve will be installed at the highest point of an inverted trap, with at least a 6 in. rise. (Use with approved recovery vessel.)

RECEIVER SAFETY RELIEF VALVE

The receiver safety relief valve must be properly vented in accordance with local codes.

NOTE:

Liquid return lines should be free draining with no traps. All interconnecting valving to be field supplied and installed.

CONNECTING TO TWO MANIFOLDS

The discharge line will be “tee’d” and drop to the manifolds. Provide a purge valve at the highest point. The liquid return lines will be “tee’d” into the main liquid return with a maximum vertical drop from the outlet stubs. The liquid return line will be pitched downstream, and provide trapless drainage to the rack.

EQUALIZING LINE

An equalizer line is recommended to be installed between the parallel rack and the condenser. Equalizer line is to be connected to the active side on split condensers. A check valve allowing flow only to the condenser and a shut off valve downstream of the check valve will be field supplied and installed.

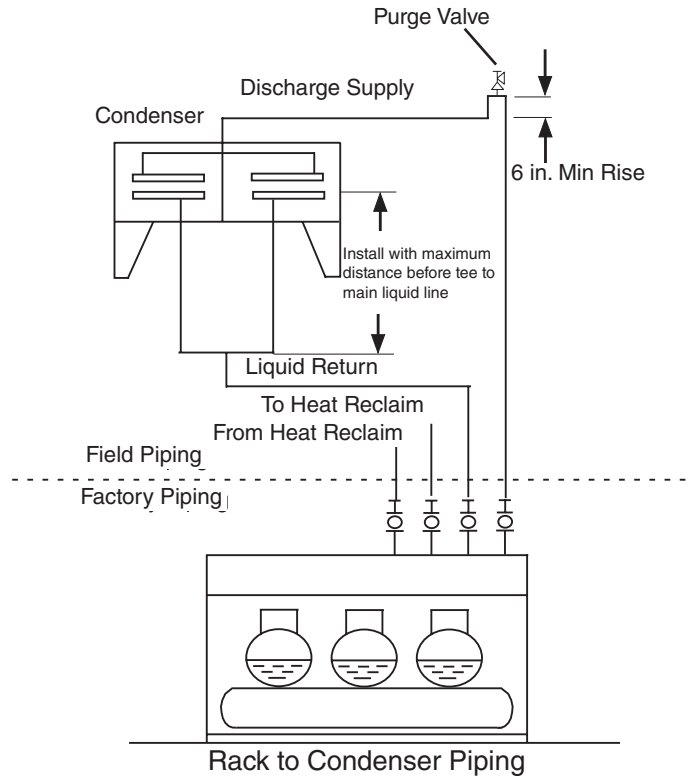

RACK TO HEAT RECLAIM

Because of the variety of heat reclaim systems, refer to the instructions accompanying the system to be installed at the site.

RACK TO REMOTE HEADER

Separates compressors from defrost and temperature controls. The rack suction stub is connected as directly as possible to the suction header. The rack liquid line stub is connected as directly as possible to the liquid header. If equipped with Koolgas defrost the rack Koolgas stub is connected as directly as possible to the Koolgas header manifold.

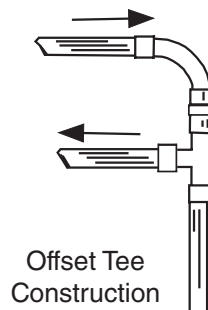

Note: The remote header may use a double suction riser to aid in oil return.

OFFSET AND EXPANSION LOOP CONSTRUCTION

For low temperature applications multiply the length of the run in feet by 0.0169.

For medium temperature application multiply the length of the run in feet by 0.0112. The product will be inches of linear expansion for the length of run.

Examples: Low temperature application, a run of 84 ft of 1 3/8 in. OD.

$$84 \text{ ft} \times .0169 = 1.4196 \text{ inches expansion.}$$

Select the smallest “Inches Expansion” figure equal to or greater than the product in step one from the table below. Follow that column down until it intersects the OD line size of the run. The number listed at the intersection is the “L” value for figuring offset an expansion loop sizes.

Equivalent Feet for Angle Valve and 90° Elbow				
Inches Expansion				OD Line Size
0.5	1.0	1.5	2.0	
10	15	19	22	7/8
11	16	20	24	1 1/8
11	17	21	26	1 3/8
12	18	23	28	1 5/8
14	20	25	31	2 1/8
16	22	27	32	2 5/8
18	24	30	34	3 1/8
20	28	34	39	4 1/8

Example:

The smallest “Inches Expansion” equal to or greater than 1.4196 is 1.5. The 1.5 column intersects with the 1 3/8 line at 21. Use “L” value 21. For an offset multiply the “L” value by 3 to determine the length of the offset.

Example: An “L” value of 21 would mean $3L = 3 \times 21$ or $3L = 63$.

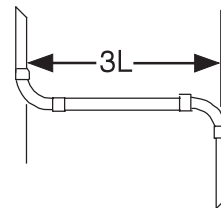

Offset Construction

The offset distance required for low temperature application for an 84 ft run of 1 3/8 line is 63 inches. For an expansion loop multiply the “L” value by 2 if hard copper and long radius elbows are used. If the expansion loop is formed in soft copper the loop diameter equals “L.”

Example: For the same 84 ft run, a hard copper loop is 42 by 42 inches. A soft copper loop is 21 by 21 inches.

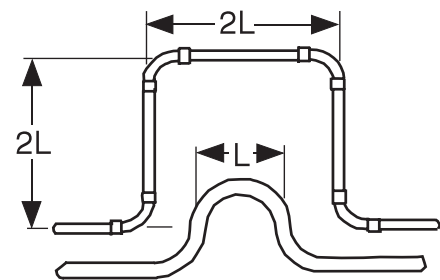

Expansion Loop Piping

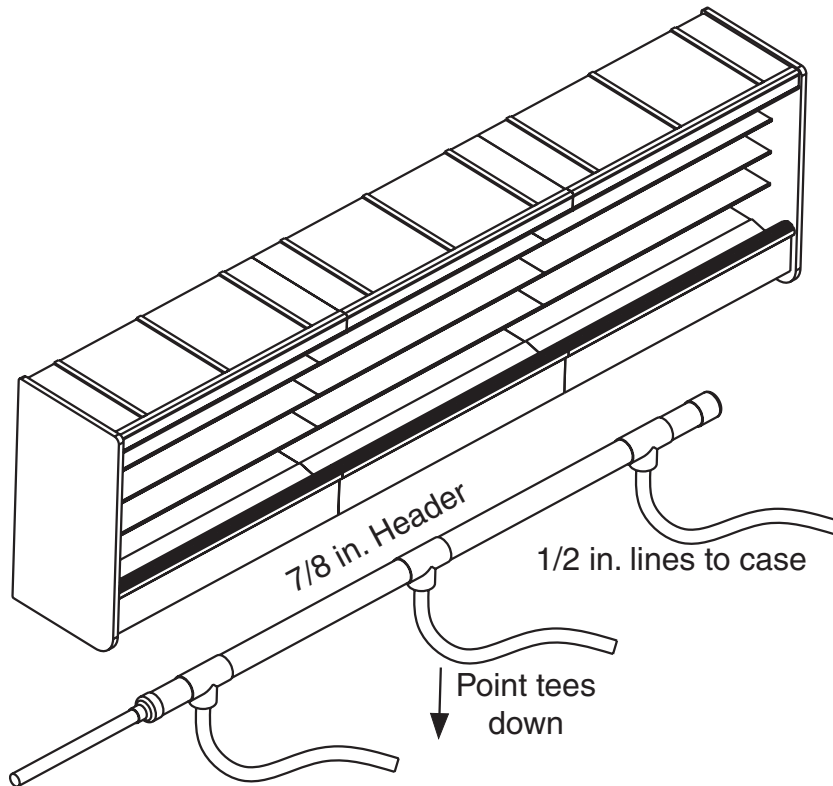

Application

Do not exceed a straight run for 100 feet without constructing an offset or expansion loop. Place the offset or loop in the middle of the run to minimize pipe shift and joint stress.

NOTE:

Sizing of all refrigerant lines is the responsibility of the installing contractor. Contact Hussmann, Application Engineering if assistance is needed.

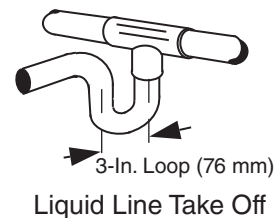
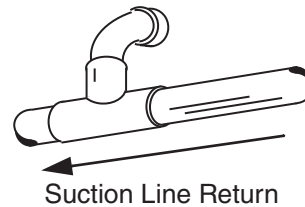

BRANCH LINE PIPING

Suction line

Pitch in the direction of flow. Line size may be reduced by one size at one third of case run load and again after the second third. Do not reduce below evaporator connection size. Suction returns from evaporators enter at the top of the branch line.

Liquid Line - Off-time and Electric Defrost

May be reduced by one size after one half other case load run. Do not reduce below evaporator connection size. Take-offs to evaporators exit the bottom of the liquid line. Provide an expansion loop for each evaporator take-off. (Minimum 3-inch diameter.)

KOOLGAS DEFROST

Maximum of 24 ft of case per branch system, except for island / coffin cases — never more than 24 ft. Increase the liquid line size inside the case by two sizes over the branch size.

Take-offs to evaporators exit the bottom of the liquid line. Provide an expansion loop for each evaporator take-off. (Minimum 3 in.)

Branch Size	In Case Size
1/2	7/8
5/8	1 1/8
7/8	1 3/8
1 1/8	1 5/8
1 3/8	2 1/8

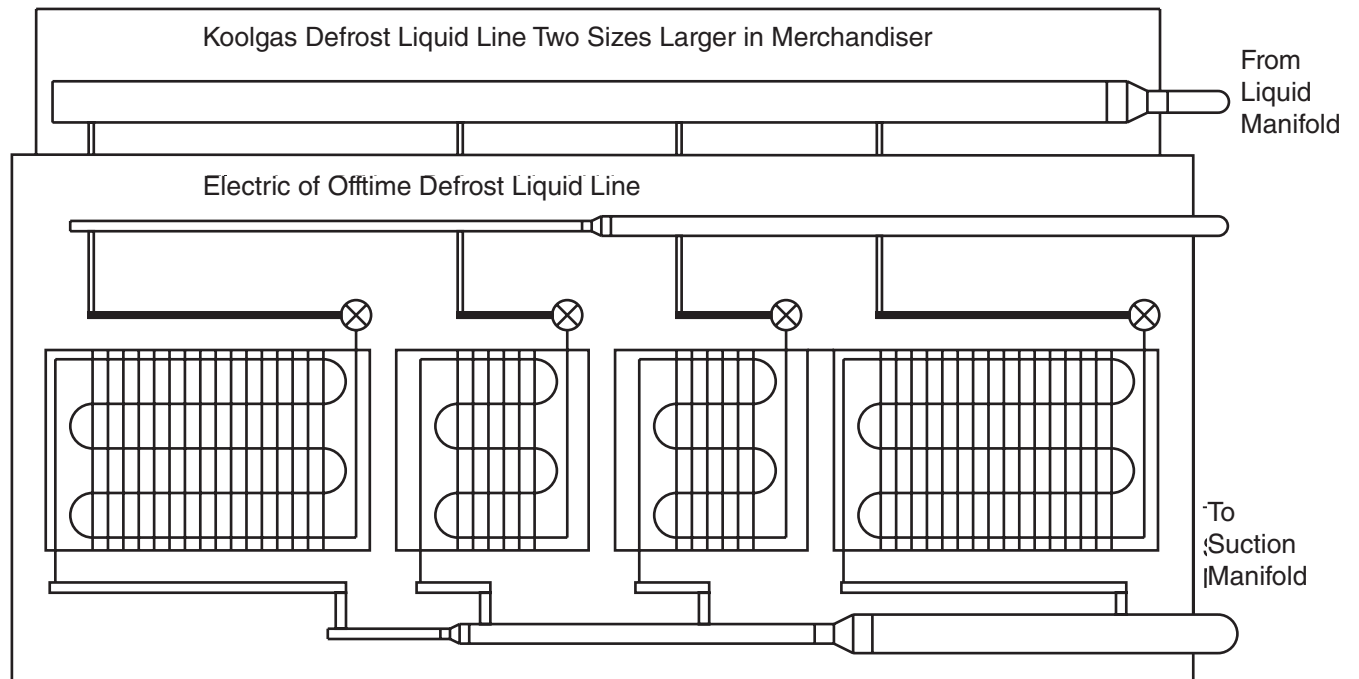

Refrigeration Line Stub Outs

Stub sizes do not match line sizes. Reduction fittings are field-supplied and installed. These are general guidelines. The installer is responsible to account for any factors which may affect the system.

Gas Defrost Systems

Do not use liquid lines smaller than 1/2 inch OD on any type of Gas Defrost system.

3-10 COMPONENT PIPING & LINE SIZING

NOTES:

EQUIPMENT START-UP PROCEDURES

GENERAL RACK COMPONENTS

Each parallel/custom rack contains the following components:

Copeland Scrolls, or 2-10 Copeland, or 2-10 Carlyle semi-hermetic, or 2-10 Bitzer, or 2-10 Bitzer or Carlye screw compressors with:

Factory piping with:

- suction, discharge, liquid header
- defrost header (if applicable)
- oil separator and return system
- receiver
- suction filters on each compressor (only for DX high side)
- liquid filter drier and sight glass
- liquid level indicator
- liquid level switch
- high and low pressure controls
- oil pressure safety control
- primary overload protection

CONTROL SETTINGS GENERAL DESCRIPTION

There are nine potential control settings required to be set up prior to startup:

- Low Pressure Controls high pressure controls
- Satellite Pressure Controls (if equipped)
- Compressor Oil Failure Controls
- Heat Reclaim Lockout
- Split Condenser Control Settings
- Condenser Settings
- Winter Condensing Pressure Controls
- EPR Pressure Settings
- Inverter Settings

SETUP SHEET

All set points are to be on a setup sheet mounted inside the door of the rack's electrical cabinet. This sheet includes all set points for field-adjusted components. (i.e. suction pressure, discharge pressure, subcooler setting).

Husmann Cascade Rack Startup Sheet

Customer		Date	
Location		Contractor	
Husmann Work Order		PM	

Note: Number all electrical connections and double check each prior to putting power to rack.

Compressor Rack Information

Rack ID		Application		Serial Number	
Rack Model		Defrost Type		Ambient Temperature	
Main Voltage		High Side Refrigerant		Low Side Refrigerant	R-744 (CO ₂)
L1-L2 Voltage		High Side Super Heat		Low Side Super Heat	
L1-L3 Voltage		High Side Suction Pressure (Actual)		Low Side Suction Pressure (Actual)	
L2-L3 Voltage		High Side Suction Pressure (RDM)		Low Side Suction Pressure (RDM)	
Control Voltage		Liquid Return Temperature		Discharge Liquid Pressure (Actual)	
EMS Controller		Sub-Cooler Liquid Temperature		Discharge at Liquid Return Pressure	

Liquid Out with Sub-Cooler

Liquid Out without Sub-Cooler

Low Side	Compressor Model Number	Serial Number	Suction Temp.	Discharge Temp.	Unloader	Oil			Variable Speed (VS)	Current Draw		
						Pressure	Net	Level		L1	L2	L3
1												
2												
3												
4												

Mechanical Settings

Low Pressure CI 120 PSIG (8.3 bar) CO 140 PSIG (9.7 bar)	High Pressure CO 580 PSIG (40 bar)	Oil Failure Alarm Out	Comp. Head Fans	Crankcase Heaters Off When Comp. On	Comp. Unloader Operates (if equipped)	Pressure Alarm in Controller		VS Bypass Functional
						High	Low	
1								
2								
3								
4								

High Side	Compressor Model Number	Serial Number	Suction Temp.	Discharge Temp.	Unloader	Oil			Variable Speed (VS)	Current Draw		
						Pressure	Net	Level		L1	L2	L3
1												
2												
3												
4												
5												
6												
7												
8												

Mechanical Settings

Low Pressure CI 10 PSIG (0.7 bar) CO 5 PSIG (0.35 bar)	High Pressure CO 395 PSIG (27.2 bar)	Oil Failure Alarm Out	Comp. Head Fans	Crankcase Heaters Off When Comp. On	Comp. Unloader Operates (if equipped)	Pressure Alarm in Controller		VS Bypass Functional
						High	Low	
1								
2								
3								
4								
5								
6								
7								
8								

Note: Number all electrical connections and double check each prior to putting power to rack.

Note: Where values are presented, record any differences in the space provided.

Air-Cooled Condenser						
Condenser Model Number	Serial Number	Fan Quantity	Correct Fan Rotation	Main Voltage	Control Voltage	Split Condenser
	ECM Motor	Standard Motors / VFD	VFD / Bypass	Verify Ambient Temperature	Condenser Temp.	Split Condenser Setpoint 45° F (7.2° C)
Desuperheating Setting						
Desuperheater Model Number	Serial Number	Fan Quantity	Correct Fan Rotation	Main Voltage	Control Voltage	
High Temp. Alarm Notice (non-adjustable, Dtemp - V ₁ temp or V ₃ temp) 108° F (42.2° C)	High Temp. Stage 1 Shutdown Compressor 2 and 3 (adjustable, Dtemp - V ₁ temp or V ₃ temp) 120° F (48.9° C)		High Temp. Stage 1 Diff. Alarm (adjustable) 100° F (37.8° C) Reset		High Temp. Stage 1 Alarm Reset 110° F (43.3° C)	
High Temp. Alarm Reset 100° F (37.8° C)	High Temp. Stage 2 Shutdown Compressor 1 (adjustable, Dtemp - V ₁ temp or V ₃ temp) 140° F (60° C)		High Temp. Stage 2 Diff. Alarm (adjustable) 135° F (57.2° C) Reset		High Temp. Stage 2 Alarm Reset 5 Minutes	
High Side Rack Setting						
Sub-Cooler Setpoints		Phase Loss Test	Liquid Alarm 10%	A-8 Set 106 PSIG (7.3 bar)	A-9 Set 20 PSIG (1.4 bar) Lower Than Hold Back	Hot Gas Bypass
CI 60° F (15.6° C)	CO 50° F (10° C)					
EPR Subcooler Set 32 PSIG (2.2 bar)		Test Alarm in Controller	Test Alarm in Controller	Verify All Transducers	High Pressure Relief 450 PSIG (31 bar)	Low Pressure Alarm 12 PSIG (0.8 bar)
Low Side (R-744) Rack Setting						
Low Pressure Cut-In/Out		Phase Loss Test	Liquid Alarm 10%	Controller HP Compressor 2 and 3 Shutdown (CO 565 PSIG [39 bar] CI 500 PSIG [34.5 bar])	Max High Head Pressure (main relief) 650 PSIG (44.8 bar)	
CI 120° F (48.9° C)	CO 140° F (60° C)					
Working Discharge Pressure 440 PSIG (30.3 bar)		Test Alarm Shuts All EEV Down	Test Alarm in Controller	Controller HP Compressor 1 Shutdown (CO 565 PSIG [39 bar] CI 500 PSIG [34.5 bar])	Regulator Valve (main relief) 585 PSIG (40.3 bar)	
Rack Low Superheat 2° F (-16.7° C)	Rack Low Pressure Alarm 150 PSIG (10.3 bar) (reset 170 PSIG [11.7 bar])		Verify Suction Pressure/Temp.	Controller High Pressure Alarm 520 PSIG (35.9 bar)	Low Side Suction Relief Setting 400 PSIG (27.6 bar)	
Rack Low Superheat Reset Time (1 minute)	Rack Low Superheat Reset Temp. 5° F (-15° C)	Controller High Pressure Notice	Backup Condensing Turns On with Power Failure	Backup Condensing Turns On 500 PSIG (34.5 bar) Off 460 PSIG (31.7 bar)		
Rack CU Holdback 110 PSIG (7.6 bar)	Rack CU HP Control 395 PSIG (27.2 bar)	Back CU LP 15 PSIG (1 bar)	Backup CU When All Compressors Off It Will Run	Recommended Minimum Operation BK CU 20 Minutes per Week		
R-744 Cascade HX Setting						
Leaving Liquid 25° F (-3.9° C) (E1 or E2)	HX1 Superheat Range 8°-15° F (°-° C) (V ₂ Temp - V ₁ Press)	HX2 Superheat Range 8°-15° F (°-° C) (V ₄ Temp - V ₂ Press)	EEV Reset After Shutdown (1 minute adjustable)	EEV Soft-Start Open 10 Percent		
EEV Shutdown Low Superheat 2° F (-16.7° C) (Atemp - Apress)				EEV Soft-Start (1 minute adjustable)	EEV Shutdown 500 PSIG (34.5 bar)	

4-4 EQUIPMENT START-UP PROCEDURES

LEAK TESTING (PARALLEL RACK)

Leaks harm the ozone layer and can be very costly over time. It is very important to follow EPA Greenchill Installation Leak Tightness Guidelines as well as Greenchill Leak Prevention and Repair Guidelines. Check that the compressor's primary ON-OFF switch are all in the OFF position.

Do not start any compressors without ensuring there is oil in them. Serious damage to the compressors may result from not having oil in them. Parallel racks are shipped with the oil loose.

Always use a pressure regulator with a nitrogen tank. Do not exceed two pounds of pressure and vent lines when brazing. Do not exceed 350 pounds of pressure for leak testing high side. Do not exceed 150 pounds of pressure for leak testing low side.

To check for system leaks do the following:

- Leave all valves closed to allow pressure into the rack. Make sure all transducers are closed when pressurizing the racks and when pulling a vacuum. Close the suction, liquid or hot gas manifolds. Each rack system is shipped with dry Nitrogen. Build the pressure in the rack unit until it reaches 150 psi. Each individual circuit should be checked.
- Each circuit can be leak checked as the pressure increases to 150 psi. Ensure that the pressure is the same throughout the assembly. Check connections and accessories for any leaks. Use an electronic leak detector. Inspect all joints. If the pressure drops sharply, this is an indication of a leak. Visually inspect all lines and joints for proper piping practices.
- Once the system has been thoroughly tested, evacuate the system to 1500 microns for the first evacuation.
- The evacuation is repeated. Install liquid and drier cores before the second evacuation. Suction filter cores are factory installed. After each evacuation, the system must be pressurized to 2 psig with dry nitrogen.
- Now evacuate the system to 500 microns for the second evacuation. Perform three evacuations in all.

LEAK TESTING (CO₂)

All refrigeration lines under the floor should be leak and pressure tested and inspected prior to backfilling. It is recommended to test piping before tying in the cases. If any leaks are found, isolate the leaks, discharge the gas and repair the leaks, and then repeat the test. This general method is not different from any other synthetic refrigeration system.

Field pressure testing is done both for leak testing and for the pressure rating of a system. It is possible to check for leaks at a lower pressure, but codes dictate that the system be proven tight at the system design pressures. For CO₂, the suction lines and evaporators are rated for 400 psi and the high side including liquid lines are rated for 650 psi. Note that the CO₂ portion of the system has already been factory pressure tested and will need to be isolated during the field pressure test to avoid opening the relief valves. Also, check to see if there are any specific job pressure testing requirements that might require higher pressure testing.

PARALLEL RACK EVACUATION / CHARGING

CO₂ has a low tolerance for moisture so care should be taken to evacuate the system before charging (similar to synthetic refrigerants). Ensure all individual line tests have been completed and all the nitrogen has been removed before completing the vacuum process. Using the correct pump (minimum of 10 CFM) and technique for the vacuum to obtain the target of 250 microns. Of course, the rack also will need to be evacuated and put under vacuum before charging.

Use a copper manifold to join the connections on the high and low side simultaneously. Ensure that the connections you use for your pump can be manually closed.

A maximum of 2 vacuum pumps will be allowed, adding up to at least 10 CFM. It is important that the oil in the pumps be changed regularly until the micron level has been reached:

- 1st oil change after 4 hours of use
- 2nd oil change after 12 hours
- 3rd oil change after 24 hours

A few things should be considered when starting the vacuum process:

1. Ensure the system is 100% free of leaks.
2. All the connections from the vacuum pump to the rack should be soft drawn copper lines 5/8”.
3. Ensure the connections have been tested before starting the pump.
4. All the caps on the rack and in the cases need to be installed and tightened.
5. All the valve packings need to be tightened.
6. Ensure liquid filters are installed before starting the vacuum.
7. Crankcase heaters should be turned on.

Note: it is important that high pressures and low vacuum not be pulled on transducers due to potential damage. Transducers should be isolated during these conditions.

Hussmann requires systems to maintain 250 microns when the pumps have been stopped for 2 hours. It is important that our start-up sheet be filled out and a picture of the gauge indicating 250 microns be kept for records.

Before charging CO₂, make sure approximately 40% of the Medium Temp Load is operating (or the hot gas bypass is operating on systems without additional Med. Temp. Loads). The high side expansion valves for the heat exchangers must be ready to condense the CO₂ from the receiver before charging. If there is an auxiliary (back-up condensing unit), assure that it is also ready to run.

Once the vacuum is broken with CO₂, charge the system thru the main filter drier. Tanks should be used without the dip tube for charging until the system is above 100 psi, to prevent formation of dry ice. After 100 psi, the dip tube may be used, drawing liquid CO₂ from the tanks for faster charging. Close the outlet of the receiver to allow filling the receiver first. Stop charging after the low liquid level alarm is satisfied or the analog liquid level indicator is at approximately 40%, after the receiver outlet valve is opened and the store liquid lines are full, with approximately 40% of the medium temp. loads calling for cooling (and valves opened).

CHARGING CONTINUED

- Open compressors – backseat service valves on suction and discharge.
- Open oil supply line immediately down stream of the oil separator.
- Pressure transducers – open angle valves.
- Leave open ball valves – to branches, condenser, heat reclaim, receiver.
- Main liquid line solenoid valve – now under control of defrost clock.
- Branch liquid line solenoid valve – Back out manual open screws.
- Suction stop EPR – under control of defrost clock.
- Split condenser – operation under pressure controls.

Note:

Remember to reinstate control to unit components jumpered to make test.

Set all mechanical pressure controls. Compressors should still be isolated from the rest of the system. Set all electronic compressor controls into switchback so the mechanical controls are in command of all system functions.

During the last evacuation look up and make a list of the required control settings for the system. A copy of the equipment legend will be needed to determine the system's design operating points. High and low pressure, heat reclaim lockout, winter control settings, and other controls on the system should be noted.

Oil Levels

Check oil levels for each compressor and the Turba-shed or other oil separator: Compressor sight glass $\frac{1}{8}$ to $\frac{1}{2}$ full, oil separator between two lower sight glasses. See legend for oil types used in parallel rack system.

If the oil is low, add the appropriate oil or lubricant to match the refrigerant used.

Evacuation

Nitrogen and moisture will remain in the system unless proper evacuation procedures are followed. Nitrogen left in the system may cause head pressure problems. Moisture causes TEV ice blockage, wax build up, acid oil and sludge formation.

- Do not simply purge the system. This procedure is expensive, harmful to the environment, and may leave moisture and nitrogen behind.
- Do not run the compressors to evacuate. This procedure introduces moisture into the compressor's crankcase oil and does not produce adequate vacuum to remove moisture from the rest of the system at normal temperatures.

 **CAUTION**

Never trap liquid refrigerant between closed valves as this could cause a hydraulic explosion.

Final Checks

Once the rack is up and running, it is the responsibility of the installer to see that all the fine adjustments are made so the rack delivers maximum temperature performance and efficiency for the customer.

These adjustments include:

- Defrost scheduling and timing
- Condenser controls
- Winter controls
- Sub-cooling Compound System Operation EPR, and ORI settings
- TEV superheat adjustment
- CPR settings High and low pressure controls Main liquid line solenoid differential

PRE-CHARGE CHECK LIST (CO₂)

While the system is being evacuated preparation for charging can begin. During any of the pull downs check:

- Merchandiser's electrical requirements and power supply electrical connections are tight and clean
- Check for proper fan operation and thermostat setting.
- Walk-in coolers and freezers electrical requirements and power supply
- Damper operation, if equipped.
- Heat Reclaim and other systems

CHARGING PROCEDURE FOR HFO/HFC OR CO₂

1. Close the outlet side of the vessel.
2. Place a charging hose of HFC /HFO on to the main liquid drier core. Look for a ½" or 5/8" king valves that can be used to charge.
 - When charging the CO₂ through the same port, make sure to use copper line or a high pressure (black Yellow Jacket type hose) the red, blue, yellow will leak.
 - Do NOT charge CO₂ through the suction.
 - Make sure the cases that are ready, and ON so that the gas is flowing through the cases. Gas will come back to the rack and fill the receiver.
 - Once at 80 percent in the receiver, then stop filling.

4-8 EQUIPMENT START-UP PROCEDURES

CONTROL CHECKS

1. During the duration of filling the receiver, all mechanical controls should be set; Low / High and verify oil failure.

- The time delays should be set, so that they do not interfere with the controller. Recommended setting should be every 15 second intervals.
- Low pressure controls should be set below the rack set point. They should be verified with a set of gauges, and run the suction stems in to verify they cut out.
- High pressure control should be done in the same manner as the low side, but go slow as the pressure increases, you will need high pressure gauges for CO2.
- These three mechanical controls should show alarm in the controller when each test is done.

PARALLEL RACK STARTUP PROCEDURE (General Instructions)

1. Once the controls have been set and the receiver is full, the Medium Temp (MT) should be started first for the Cascade system.
2. Once there is enough load to keep the racks running, look at all the amperages on all the compressors. Record this data for future reference (can be written on the control panel).
3. The Hold Back Valve(s) (A-8 & A-9) should be set. See next page for adjustment instructions.

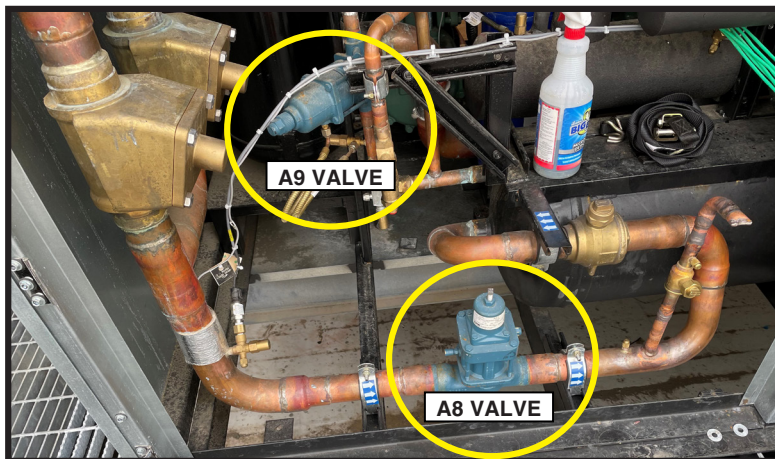

ADJUSTING THE HOLD BACK VALVE (A-9 VALVE)

- Connect high side manifold gage set to outlet side of the receiver pressure regulator.
- Close the receiver valve just downstream from the receiver pressure regulator.
- Connect center hose to suction line and bleed pressure off to suction.
- Close gage set and pressure indicating on gage is valve set point.
- Increase or decrease valve setting until desired set point is achieved.
- Tighten lock not and recheck valve setting.
- Remember to open the receiver valve!

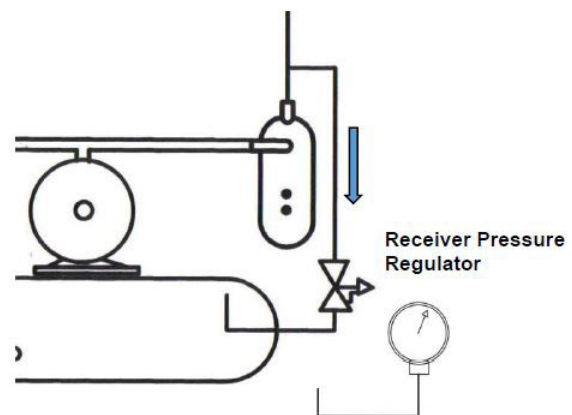

ADJUSTING THE A8AL DIFFERENTIAL RECEIVER PRESSURE REGULATOR FLOW-CON A8 SERIES VALVE

Most of the time we find that the Parker A9 outlet pressure regulator is used for the receiver pressure regulator to control receiver pressure in cooler ambient temperature. We are all familiar with the adjustment and setting of this valve. However the application engineer has the ability to choose from the Parker A9 series valve, a differential check valve or the A8AL Parker differential regulator valve. From time to time we have seen the use of A8AL DIFFERENTIAL valve on Hussmann refrigeration racks. This valve selection has caused some confusion in the adjustment and setting of this valve.

The Parker A8 valve can be an inlet pressure (as used as the condenser flooding valve), an outlet pressure regulator and a differential pressure regulator. While the valves look alike the A8AL differential valve will have an External connection for a remote pressure. This vent line will connect and read outlet valve pressure. Always check the valve model before setting

Flow-Con A8 Series Valve

A8 Valve Nomenclature

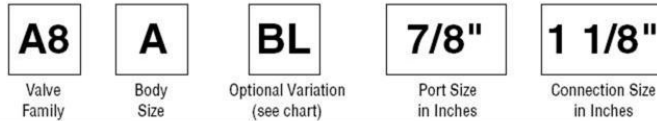

Valve Types: A8A, A81, A82. All are inlet pressure regulators. Optional adapter functions are as follows:

"S" Suffix	Inlet Regulator with Electric Shut-Off
"B" Suffix	Inlet Regulator with Electric Bypass Feature
"L" Suffix	Differential Pressure Regulator
"BL" Suffix	Differential Regulator with Electric Bypass Feature
"OE" Suffix	Outlet Pressure Regulator
"OES" Suffix	Outlet Pressure Regulator with Electric Shut-Off



SETTING THE CONDENSER FLOODING VALVE IN HOT WEATHER

During hot ambient conditions it may not be possible to get condenser pressure below target set point to adjust the A8 valve.

We can still set the A8 valve in hot weather using this method. The Parker manual states the one full turn of the A8 valve equals 70 psi.

1. If our present condensing conditions are running at 230 psi.
2. Our target set point is 180 psi.
3. We add one turn of 70 psi to our target of 180.
4. This equals 250 psi.

Set point	180	PSI
One Turn	+ <u>70</u>	PSI
	250	PSI

Set the condenser flooding valve to 250 PSI and then open one full turn to equal 180 set point.

The standard A8 valve set-point should be **77F**, measured from a P/T chart. This is a general guideline for all refrigerants other than R-134A or R-513A (lower pressure refrigerants), which should be set around **87F**. This value should be adjusted based on customer preference.

WINTERIZING SETUP

Winterizing Control WorksheetRefrigerant 404 A

Receiver Target Saturated Temperature in

Degrees = 70° Converted to Pressure = 149 PSI

Control	Setting	
Receiver Pressure Regulator		149
Condenser Flooding Valve	+ 15 PSI	164
Condenser Fans Set Point	+ 15 PSI	179

PARALLEL RACK STARTUP SEQUENCE

1. Prior to starting the rack up or putting power to the rack, make sure all the electrical connections in the rack panels and compressors are tight. All case controller panels for all coolers and freezers, and cases panels supplied by rack manufacturer should be checked.
2. At least 40% of the rack evaporator load should be available prior to rack startup.
3. Several tests should be performed on the rack prior to running. (Note: Control must be powered up.)
 - a. Perform a phase loss test to make sure all the suction valves on the rack shut down.
 - b. Once the phase loss is reset, all the suction valves should start to open slowly.
 - c. Simulate a rack shutdown to ensure case controllers automatically close all EEVs.
 - d. Simulate a low superheat on the all the cases to verify the liquid and suction will shut down. If not this could cause excessive liquid flood back to the rack.
 - e. Leak detection in all boxes and motor room must be tested, and fully functional. The exhaust fan should be in operation prior to charging of the system.
 - f. For indoor or machine room applications, leak detection is not recommended to shut down the rack as this will result in more discharge.
 - g. Verify rotation on fans on Desuperheater (Condenser x 2).
4. When starting the rack run all the compressors other than the lead with the VFD drive. After everything else is running, the lead (VFD) compressor should be turned on.
5. Check the system operating temperatures and defrost time. The length and number of defrost cycles must be set in accordance with case manufacturers' recommendations and owner provided schedule for defrost.
6. A final defrost schedule must be provided to the store manager during the week of grand opening as well added to the door of the rack. All work within start-up procedure needs to be recorded in a logbook kept in the motor room.
- 7. After the compressor is started, continue charging until the system has sufficient refrigerant for proper operation. During start-up, no compressor is to be left operating unattended and unwatched until the system is properly charged with refrigerant and oil.**
8. After the system has been in operation for a minimum of 7 days, all expansion valve strainers must be cleaned and is recommended for valves with removable screens.

Note: If this a new build, it is recommended that the freezer boxes are set at 35° F, and run for a minimum of 48 hours, then drop to 10° for 24 hours. This will pull the moisture out of the floor in the freezers. If the customer has a requirements or specification, follow it.

4-14 EQUIPMENT START-UP PROCEDURES

Monitor the following:

1. Flood back
2. Keep an eye on oil level in the oil separator and well in compressor.
3. Verify oil pressure on the compressors that have external oil pumps. This should be recorded on the panel as well.
4. Pull the gas from cores back into the rack. Be careful removing the gas from the shell.
5. It is recommended to place the filters back in the suction shell, particularly for CO2 cascade side, because there is a suction heat exchanger downstream of the suction filter. If there is no filter over a period of time, any debris in the system will stop-up the plate heat exchanger.

STARTUP PROCEDURE HFC/HFO or CO2

1. For all cases that need to be started - has all the EMS been checked out and ready
2. For all cases that need to be started - has all the electrical connections been completed so that all that is left for the electrical is to turn the breaker on?
3. Check the following for the rack system, prior to applying power to the rack
 - Check compressor control box 1 connections are tightened
 - Check that all connections in the rack panel are tightened and complete
 - Check that there is no debris in the panel
 - Make sure all transducers have been verified and are “zero-ed” out
4. Check customer-specific controller manufacturer tolerances to place and offset.
As a general rule - If suction transducer pressure is over 5 psig, transducer needs to be replaced. For the discharge side anything over 10 psig needs to be replaced.
5. The oil and suction, liquid, oil filters should be installed after the last vacuum break and pull-down.
6. Verify main power voltage and control power. Record it, and write on the panel next to single point.
7. Once the power is applied, make sure to pull a wire off the phase loss monitor to make sure the rack drops out and will alarm through the controller. If this step is completed at this time, there is no need to do it when the rack is running.
8. Verify all drives have the correct parameters. Parameters are supplied with the rack documents.

9. The condenser fans or (de-superheater) needs to be checked to ensure proper fan rotation.
10. Verify that the split-condenser valve operates properly. The setpoint may need to be lowered to have it go into split. Oil failures can be checked prior to charging the unit. You would typically do this prior to running the compressor. When you leave the main compressor breaker off, the contactor would pull in. It would time out and trip oil. If the contactors are chattering, turn off contactor. Pull contact out. Take it apart, and clean magnetic on the backside of the contactor with emery cloth. Put back together.

AFTER STARTUP

- Oil and Filter Replacement

1. Charge the rack fully with oil. After the rack is full, it is recommended to change the oil, and change the suction, liquid and oil filters within 30 days or as required by the customer's specifications. Hussmann supplies filters and oil for startup and enough for one oil change after startup.
2. Additional oil changes may be needed based on customer-specific requirements and to ensure the unit is clean.

NOTE: Any time the system is opened after this point, the drier cores must be replaced.

3. Leak test with a CO₂ sniffer type tool.
4. Defrost lengths and pressures should be verified to ensure that energy consumption is at a minimum.
5. Always check that each case (after defrost) temperature exceeds 32° F in the evaporator and the coil is clear.
6. If the coil is not clearing using the recommended defrost settings call Hussmann for review.
7. Ensure that all the programming is finished and well understood by servicing contractor.
8. Ensure that all temperature sensors and pressure sensors are well calibrated.
9. Ensure all control panels are closed.
10. Record CO₂ level in receiver for future reference.
11. Fill out start up form (sample shown on Page 4-2), and send to Hussmann a maximum of 3 weeks after initial start up.



Thermostat Settings

Adjustments to electronic controls:

Thoroughly inspect all field piping while the equipment is running and add supports where line vibration occurs. Be sure additional supports do not conflict with pipe expansion and contraction.

When merchandisers are completely stocked, check the operation of the system again. At 90 days recheck the entire system, including all field wiring. Future maintenance costs may be reduced if an oil acidity test is run at this time. Replace acidic oil.

SETTING EXPANSION VALVE SUPERHEAT**Primary Method for Setting Expansion Valve Superheat:**

- Measure the temperature of the suction line at the point the bulb is clamped.
- Obtain the suction pressure that exists in the suction line at the bulb location or by either of the following methods:

(1) If the valve is externally equalized, a gauge in the external equalizer line will indicate the desired pressure directly and accurately.

OR

(2) Read the gauge pressure at the suction valve of the compressor.

- Add the estimated pressure drop through the suction line between bulb location and compressor suction valve. The sum of the gauge reading and the estimated pressure drop will equal the approximate suction line pressure at the bulb.
- Convert the pressure obtained in **(1)** or **(2)** above to saturated evaporator temperature by using a temperature-pressure chart.
- Subtract the two temperatures obtained from these — the difference is superheat.

Secondary Method for Setting Expansion Valve Superheat:

- Before attempting to set a TEV be sure the merchandiser is within 10°F of its normal operating range.
- Attach temperature probes at both the TEV bulb location (under the clamps) and between the TEV and the evaporator inlet.
- While the valve is hunting the temperature difference between the two probes should not exceed 3-5°F. The differential may fall to zero. To reduce differential, turn the adjusting stem counter clockwise and wait at least 15 minutes before checking results.

COMPONENT TESTING

Remove power to the system. Unplug the Temperature Sensor from the Module. The Sensor should ohm out between 1,600 ohms and 100,000 ohms.

Leave the Sensor unplugged and restart the system. There should be no voltage between terminals “S” and “L2” on the Module. The inlet and outlet sides of the injection valve should feel the same temperature. After one minute, the alarm relay should trip. Remove power to the system. Press the manual reset on the Module.

Using a small piece of wire jump the Sensor circuit at the female plug in the module. Restart the system. There should be voltage between terminals “S” and “L2” on the module. The outlet side of the Injection Valve should feel colder than the inlet side. After one minute the alarm relay should trip.

Remove power to the system. Press the manual reset on the Module. Remove the jumper wire and plug in the Temperature Sensor. Restart the system.

The Alarm Circuit has three terminals in the Control Module: “L” – Common; “M” – Normally Closed; and “A” – Normally Open. “L” and “M” are wired into the compressor control circuit so an alarm condition removes the compressor from the line and power to the Module. A manual reset is required to call attention the alarm condition.

Y825 VALVE ADJUSTMENT (IF USED)

1. Close all the oil float service valves. This is done by turning the valve stem in the clock wise direction until they bottom out.
2. Connect a low pressure gauge to the suction header.
3. Connect the low side gauge hose of a gauge manifold set to the schrader connection at the end of the supply oil manifold.
4. Connect the center hose of the gauge manifold set to the suction header.
5. Open the hand wheel on the gauge manifold set for a few seconds then close it off again.
6. Subtract the suction header pressure from the oil header pressure.
7. If adjustment is necessary, turn Y825 valve adjustment stem in the clock wise direction to increase pressure and turn it counter clockwise to reduce pressure. Always open the hand wheel on the gauge manifold for a few seconds and recalculate oil pressure after every adjustment.
8. Remove all gauges from the system.
9. Open all the oil float service valves.

LIQUID LINE DIFFERENTIAL VALVE ADJUSTMENT (IF USED)

1. Shut off the Kool/Hot gas ball valve on the first gas defrost circuit and put that circuit in defrost. Make sure that no other circuits that are gas defrost, are in, or will go in defrost while adjustments are being made.
2. Connect two high side gauges, one on each side of the liquid line differential valve.
3. Subtract the outlet pressure from the inlet pressure, this is your differential pressure.
4. If adjustment is necessary, turn valve adjustment stem in the clock wise direction to increase the deferential pressure and turn it counter clock wise to reduce the deferential pressure.
5. Remove the high side gauges.
6. Take the first gas defrost circuit out of defrost and open the Kool/Hot gas ball valve for that circuit.

EVAPORATOR PRESSURE REGULATOR ADJUSTMENT

1. Connect a low pressure gauge to the suction manifold.
2. Connect a low pressure gauge to the evaporator side of the EPR valve in need of adjustment.
3. Make sure the suction header pressure is 5 to 10 psig lower than the desired set point.
4. Turning the valve adjustment stem in the clock wise direction will cause the evaporator pressure to go up. Turning the stem in the counter clock wise direction will cause the evaporator pressure to go down.
5. Wait a few minutes to allow system pressures to stabilize then recheck the valve set point.
6. Remove the low side gauges.

LOW PRESSURE CONTROLS

1. Turn off the control circuit for the compressor that needs it's low pressure control set.
2. Bypass any time delays, electronic rack control relay, electronic overload module with built in time delay and switch back relay if used.
3. Connect a low pressure gauge to the suction header.
4. Front seat oil supply and oil equalizer line service valves on the compressor whose low pressure control is being adjusted.
5. Make sure rack suction pressure is above the desired cut in point of the low pressure control. You may have to turn off the other compressors to raise the suction pressure.
6. Connect a low pressure gauge to the compressor suction service valve on the compressor whose low pressure control is being adjusted.
7. Front seat the suction service valve.
8. Jump out the low pressure control and turn on the compressor. Look at the gauge connected to the suction service valve, when the pressure reaches 0 psig turn off the compressor.
9. Adjust the cut in point of the low pressure control 20 to 25 psig above the desired cut in point by looking at the scale on low pressure control.
10. Slowly open the suction service valve and watch the low pressure gauge. When the pressure reaches the desired cut in close off the suction service valve.
11. Remove the jumper on the low pressure control. Turn the compressor control circuit on. Slowly turn the cut in adjustment toward the desired cut in point. When the compressor turns on you have reached your desired cut in point.
12. Slowly open the suction service valve and watch the gauge connected to the suction service valve. Make sure the compressor cuts in at the proper pressure. If fine tuning of the low pressure control is needed, front seat the suction service valve again then adjust the cut in on the low pressure control.

13. Slowly open the suction service valve while watching the gauge connected to the suction service valve. Repeat until the desired cut in point is reached. When you are finished adjusting the cut in of the low pressure control open the suction service valve fully.
14. Turn the differential adjustment on the low pressure control to a value greater than your desired cut out point.
15. Slowly front seat the suction service valve while watching the gauge connected to the suction service valve. When the desired cut point is reached stop turning the suction service valve.
16. Slowly turn the differential adjustment on the low pressure control towards the desired cut out point. When the compressor turns off you have reached your desired cut out point.
17. Open the suction service valve fully then begin to front seat it while watching the gauge connected to the suction service valve. Make sure the compressor cuts out at the proper pressure. If fine tuning of the low pressure control is needed, adjust the cut out on the low pressure control. Repeat this step until the desired cut out point is reached. When you are finished adjusting the cut out of the low pressure control open the suction service valve fully.
18. Disconnect the low pressure gauges from the system.
19. Open oil supply and oil equalizer line service valves that were closed during Step 4.
20. Turn off the control circuit on the compressor whose low pressure control you set.
21. Remove any jumpers you installed during Step 2.
22. Turn the compressor control circuit back on.

HIGH PRESSURE CONTROL ADJUSTMENT

1. Set the cut out of the high pressure control to the desired set point. Use the scale on the high pressure control to set cut out point.
2. Set the cut in of the high pressure control to the desired set point. Use the scale on the high pressure control to set cut in point.



Hussmann Refrigeration Equipment Commissioning Sign Off Sheet

SAMPLE SIGN-OFF SHEET

All sections of this document must be completed before the installation will be accepted.

Store No. _____ Address _____

Customer _____

Grand or Re-Opening Date _____
(Date of project Grand or Re-Opening - for warranty purposes)

Project Type _____
(New Store / Remodel)

Installing Contractor _____
(Contractor's name and branch location if applicable)

Refrigerant _____
(R449, 448, 513, CO2)

System Type _____
(DX / CO2 / CU)

EMS System _____
(RDM)

Comments:

Approval

The work carried out during this project is complete and the standard achieved is acceptable.

*Refrigeration Service
Contractor (name)*

*Refrigeration Service
Contractor (Signature)*

Date

By signing this form, you are confirming that the work detailed above is complete and that all systems are operating as intended.
All handover documentation has been completed and you are satisfied with their contents.
All issues are either resolved or you are satisfied with the plan for resolution.

SEQUENCE OF OPERATION & COMPONENT OVERVIEW

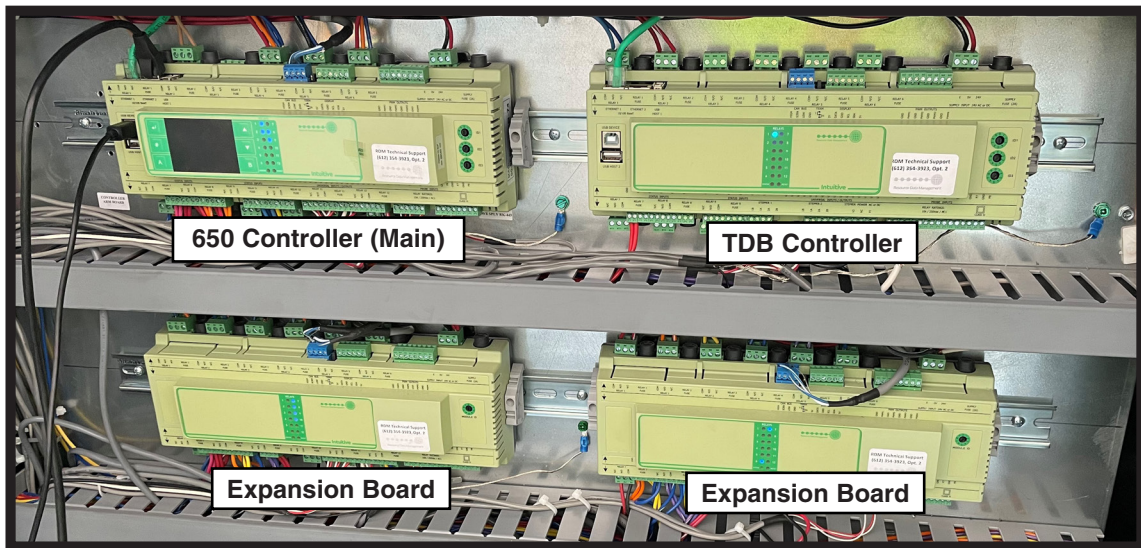

GENERAL OVERVIEW OF SEQUENCE:

1. SYSTEM INPUTS & CONTROL

Refrigeration rack control is accomplished using an electronic controller (or similar rack controller) that is wired in series with mechanical safety switches for oil pressure and head pressure. The controller maintains refrigeration temperatures and pressures in the system at the unit, condenser, cases and walk-ins by adjusting electronic regulating valves, digital compressors and the variable frequency drive (VFD) condenser fans. If the controller fails, backup mechanical switches allow the unit and condenser to maintain basic refrigeration function.

The unit-mounted rack controller monitors system inputs, controls system outputs, and provides alarm functionality, with electro-mechanical safety devices serving as back up should the controller fail. The rack controller must receive a Run/ Stop command, as well as the saturated suction temperature (SST) operating point, via the BAS controller. The SST operating point input must be within the allowable range for each unit. (see setpoint chart) An invalid SST input operating point will not be accepted, and the rack controller will revert instead to the last valid operating point assigned.

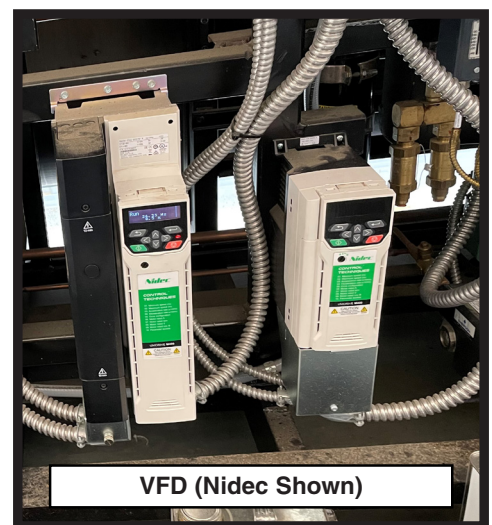

5-2 SEQUENCE OF OPERATION & COMPONENT OVERVIEW

2. COMPRESSORS:

Compressor staging is achieved through a control point (suction pressure setpoint) located in the corresponding return suction header. Compressors are operated under the direction of the rack controller, having outputs wired in series with individual compressor safety devices – including a compressor high-pressure switch for high discharge pressure protection, low-pressure switch for backup control and/or low suction pressure protection, and other electronic safeties for individual compressor oil differential pressure and/or oil-level monitoring (refer to CoreSense/OMB oil protection).

The compressor safety devices provide emergency compressor shut-down and/or backup to the unit controller. The unit control system operates and alarms before the electro-mechanical safeties operate.

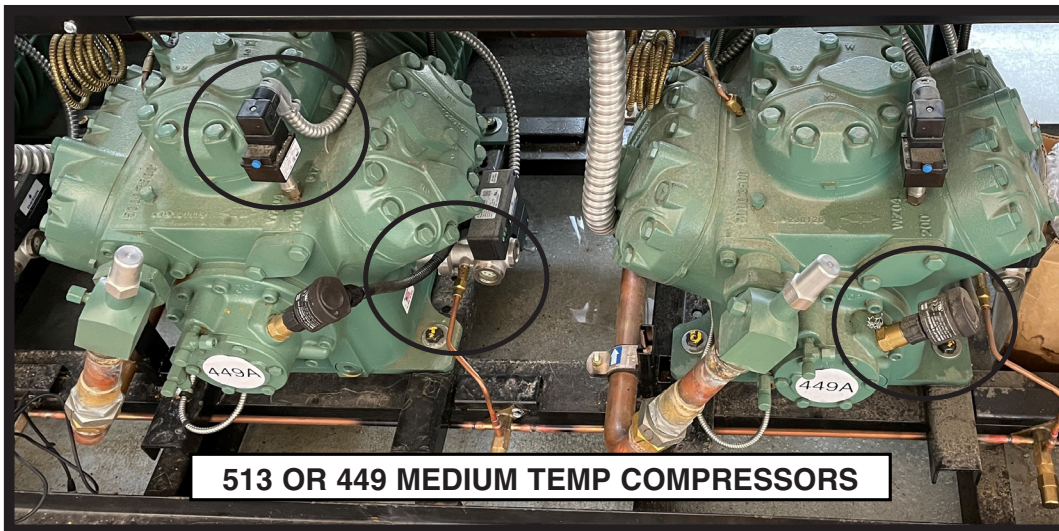

The compressor safety devices provide emergency compressor shut-down and/or backup to the unit controller. The unit control system operates and alarms before the electro-mechanical safeties operate.

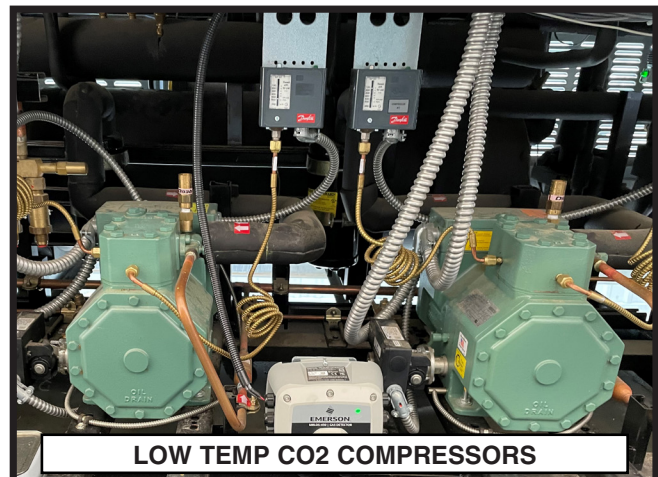

3. CONDENSER CONTROL

Various condenser control strategies can be employed and programmed into the rack controller. Hussmann recommends a strategy of 10 to 15F temperature difference (floating) head pressure between the drain line pressure (converted to temp.) and the ambient. This set-point becomes the target for cycling fans or for VFD control.

The minimum set-point must be above the A8 setpoint.

Split Condenser Operation

The recommended set-point for split condenser is based on the ambient temperature. The general rule-of-thumb is 65F. This can be adjusted based on customer preferences.



4. DESUPERHEATER CONTROL STRATEGY (only for CO2 Cascade)

The CO2 requires a desuperheater to avoid damaging the plate heat exchangers. This has a 3-way bypass to keep the leaving temperature from dropping too much and leading to erratic performance. The standard leaving CO2 set-point is 95F.

The desuperheater can be done as a separate circuit within the high side condenser or can be a separate air-cooled unit (typically one fan). This fan is intended to run 100% of the time, but could be programmed to shut-off whenever the 3-way bypass valve is bypassing 100%.

5. SUBCOOLING:

The liquid supply is typically subcooled thru a brazed-plate heat exchanger (BPHE) in order to maintain a target liquid supply temperature. The TEV should be set with the highest possible superheat that will still maintain the desired liquid temperature. EPR setting is listed on the store legend. Thermostat setting is typically 50°F with minimum differential, or customer specifications.

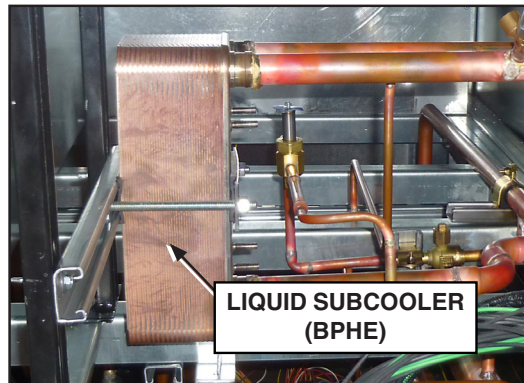

Temperature control is achieved via the electronic expansion valve (EEV), electronic evaporator pressure regulator (EEPR) and mechanical controls, which together regulate the flow of refrigerant thru the evaporator side of the BPHE, thereby absorbing heat from the main liquid line.

The rack subcooler control modulates both valves, based on the pressure and/or temperature of the suction gas exiting the BPHE. The EEPR is used to maintain a target suction pressure, while the EEV maintains a target superheat condition.

A liquid line solenoid valve must be closed when the leaving liquid temperature is satisfied or there are no compressors running.

6. LIQUID SURGE (IF USED)

By lowering the temperature of the liquid supplied to the TEV, the efficiency of the evaporator is increased. The lower temperature liquid refrigerant produces less flash gas exiting the TEV. Since mechanical subcooling uses a direct expansion device, it is not limited by ambient temperature. A Liquid Line Solenoid Valve and a TEV control refrigerant to the subcooler. An EPR prevents the subcooler temperature from dropping below desired liquid temperature. Electrically, a thermostat responding to main liquid line temperature controls a solenoid valve on the liquid supply line.

The surge valve directs flow of refrigerant from the condenser through the receiver (flow through), or around the receiver (surge) in response to ambient subcooling obtained in the condenser. During low ambient conditions the receiver pressure regulator will aid in maintaining pressure in the liquid header. The surge valve reacts to liquid temperature from the condenser.

When the liquid temperature is below 75°F, the surge valve will open allowing subcooled liquid to bypass the receiver into the liquid header. When the liquid temperature is above 75°F, the surge valve will close forcing liquid into the receiver and then into the liquid header.

The Surge Valve is controlled by a t'stat that closes on drop of liquid drain temperature. The correct setting may have to be adjusted due to lower flooding valve settings.

7. TWO-STAGE MECHANICAL SUBCOOLING

Due to wide ranges of load requirements, a two stage subcooling control will be used. In two stage subcooling, there are two expansion valves piped in parallel; one valve approximately one-half the size of the other.

The largest valve will be in operation during full load conditions. When the load requirements are reduced, the smaller valve will be turned on. At this time, the larger valve will be shut off. When the liquid drop leg reaches the subcooled liquid design point, both valves will be shut off.

Two-Stage Mechanical Subcooler Control

Electrically, a thermostat responding to liquid drop leg temperature will turn on the subcooler. The setpoint of this control will be the subcooling temperature design point.

The setpoint of the control for the one-half or full expansion valve is the liquid drop leg as well. This setpoint is determined by the expansion valve selection and will vary from store to store.

8. RACK REFRIGERANT FLOW

This section details the refrigeration process by tracking the refrigerant flow through the rack components. Oil separation and return is explained as well. See diagram next page.

The rack is designed with an adequately-sized receiver for proper refrigerant management. The compact design reduces height and width requirements as well as providing convenient access to components for easy maintenance and service. In the diagrams refrigerant flow direction is generally clockwise and indicated by directional arrows. Electrical solenoid valves carry the same initial abbreviations as in the electrical schematics.

Refrigeration lines not actually in the cycle being discussed are shown closed or removed. Pressure oil lines will retain a fixed pattern. The flooding valve maintains head pressure in low ambient conditions by restricting liquid refrigerant flow from the condenser. This causes liquid refrigerant flow to be backed up in the condenser, thus reducing available heat transfer surface and causing the discharge pressure to rise. The receiver is a holding vessel for liquid refrigerant. The receiver compensates for fluctuations in liquid requirements during changing loads, defrosts and weather.

The main liquid pressure differential valve functions during gas defrost to reduce pressure to the liquid header. The reduced pressure allows reverse flow of refrigerant gas through the evaporator necessary for an effective defrost.

The liquid header distributes liquid refrigerant to all branch liquid lines. The branch liquid line solenoid valve closes off refrigerant supply to the evaporator. The valve also allows back flow of refrigerant into the liquid header.

9. HEAT RECLAIM CYCLE

The heat reclaim system returns heat to the store that has been removed from the refrigeration units. This heat, which would otherwise be wasted, is returned in useable form through a heat reclaim coil. The heat reclaim 3-way valve energizes during reclaim mode diverting discharge gas to a remote mounted air reclaim coil or water heating coil or other heat exchanger. After the discharge gas passes through the reclaim coil, it returns to the system through a check valve and then to the condenser. The check valve assures no back flow and flooding when heat reclaim cycle is off. During heat reclaim, the heat reclaim coil rejects superheat from the refrigerant vapor and the condenser coil rejects latent heat and produces quality liquid for the refrigeration process. The heat reclaim coil should not be oversized.

There are three types of heat reclaim water, air, glycol. Water uses a special water tank that preheats water to 140°F. This helps reduce electric output of gas fired hot water heater. Air heat reclaim allows the waste heat to be used to either heat the store ambient air or to preheat air prior to air-conditioning. Glycol heat reclaim allows glycol to heat a cold aisle or a side walk-in or fryer, etc.

10. OIL SYSTEM CYCLE

Discharge refrigerant carries droplets of oil from the compressors' lubrication system. The Turbashed or other oil separator returns the oil from its reservoir along a high pressure line to the oil pressure differential regulator valve. This valve reduces the oil pressure to between 20 and 25 psig above the crankcase pressure of the compressor, providing even flow of oil to the oil level regulators or floats.

To balance oil level among the compressors an equalizing line returns any excess oil in one oil level regulator to the rest of the system. A check valve is placed in the equalizing line between the low end satellite and the rest of the system. The check valve is necessary to keep the low end satellite from filling up with oil. With a high end satellite, note that the satellite has no equalizing line.

NOTE: Every suction group or satellite compressor should have its own pressure differential valve.

Adjustments are made at the bottom of the valve. To adjust, remove the valve cap and turn the stem with a valve wrench. To increase the differential, screw the stem in; to decrease the differential, screw the stem out. One turn gives 4 psi of adjustment.

NOTE: An increase in differential means higher oil pressure into the floats.

Oil Charging

Oil selection is dependent on compressor manufacturer. For CO₂, Copeland may use either BSE-85K or Emkarate 68 oil where Bitzer requires BSE-85K oil. For HFC, Copeland may use Solest 32 (or 998-E022-01), where Bitzer requires BSE-32. Initial oil charging should be performed while the system is under vacuum. Check all compressors for proper oil levels and adjust if necessary. Add sufficient oil to fill the oil reservoir.

COMPONENT OVERVIEW

EPR VALVE OPERATION

Evaporator pressure regulator valves respond to upstream pressure and are used to maintain a minimum evaporator temperature.

Two key points when working with rack mounted EPRs:

- Pressure drop from the merchandiser to the machine room. The final test for setting an EPR should always be evaporator discharge air temperature or product temperature.
- The second is that low pressure drop EPR valves, like those used on the rack, require an external high pressure supply to power the main piston chamber. This high pressure supply must maintain a positive differential of at least 50 psig above the downstream side of the valves. Lower pressure differentials may cause valve malfunction.

Basically all EPR and ORI valves open on upstream suction pressure rise. Achieve the desired suction pressure by balancing Adjustment Spring (#1) against Upstream Suction Pressure (#2) and Fixed Pressure Counter Spring (#3). As upstream pressure rises it closes the high pressure inlet to the Main Valve Chamber (#4). The downstream bleed off reduces the Main Chamber pressure to the point that piston spring (#5) and Upstream Pressure (#6) open the main valve.

Note:

EPR Valves equipped with a Suction Stop Solenoid are used with Koolgas Defrost. When de-energized, this solenoid causes the Main Valve to close.

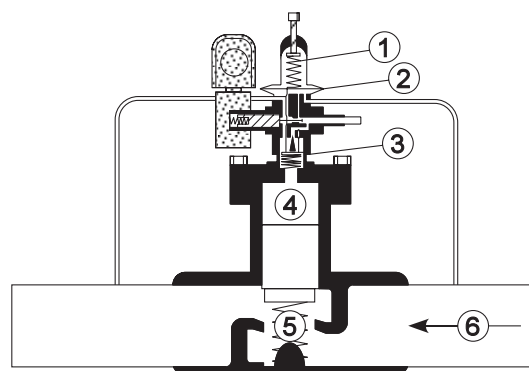

EPR Valve with Suction Stop Solenoid

MAIN LIQUID LINE SOLENOID VALVES

The Sporlan Main Liquid Line Solenoid Valve goes into differential mode when the coil is de-energized or fails. When the Pilot Port (1) opens, upstream pressure (2) fills the Main Valve Chamber (3) and forces the Main Valve

towards a closed position. The downstream pressure (4) falls to the point that the Pilot Valve Spring (5) can not keep the downstream outlet closed. The Main Valve Chamber starts to empty and upstream pressure forces the main valve towards open.

Differential Mode Quick Test

- Connect pressure gauges up- and downstream of the valve.
- All branches on the rack must be in refrigeration mode.
- Disconnect power to Solenoid.
- Check gauges for differential.

NOTE: Low refrigerant demand may prevent the differential from building up to the valve's real setting — upstream pressure.

Downstream pressure
+ pilot spring pressure
= upstream pressure

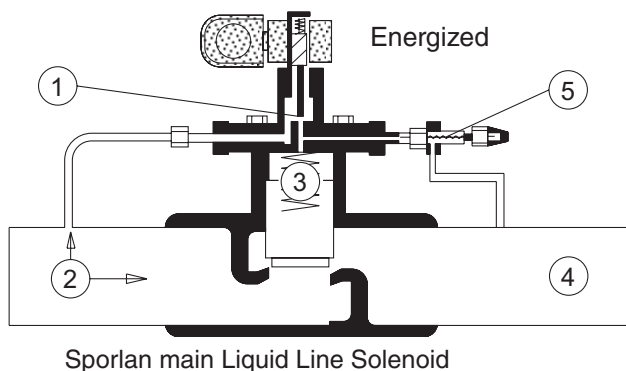

BRANCH LIQUID LINE SOLENOID VALVES

The Branch Liquid Line Solenoid Valve closes off refrigerant supply to the evaporator, yet allows back flow of refrigerant into the Liquid Manifold for Koolgas Defrost.

When the Solenoid is de-energized the Valve Port (1) is held closed. Higher Pressure (5) upstream fills the Valve Chamber (3) through the Equalizing Port (4), keeping the Valve closed.

In refrigeration the Valve Port (1) opens, emptying Valve Chamber (3) through the Check Valve (2) faster than the Equalizing Port (4) can fill it. Higher Pressure (5) upstream forces the Valve open.

During Defrost, Valve Port (1) opens, removing kick spring force from the valve. Higher Pressure (5) downstream back flows, closing the Check Valve (2) and forcing the Valve up. Equalizing Port (4) allows Valve Chamber (3) pressure to escape upstream.

NOTE:

The Solenoid of the branch valve is energized during refrigeration and from back flow during defrost.

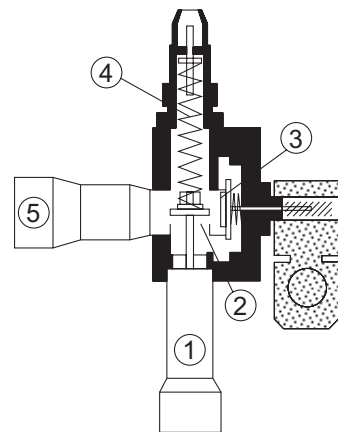

Differential Mode - Coil De-energized

3-WAY SPLIT CONDENSING VALVES

A 3-Way Split Condenser Valve directs the refrigerant to either both coils of a split condenser or one coil of a split condenser. When the solenoid is de-energized, the seat disc is in the position that evenly splits the flow between both coils of the condenser. When the solenoid is energized, the seat disc moves to close the upper port.

The refrigerant flow is then directed to the condenser coil that is set to operate all year. The “B” version of this valve has a small bleed port that pumps out the condenser coil that is not operating when the valve is energized.

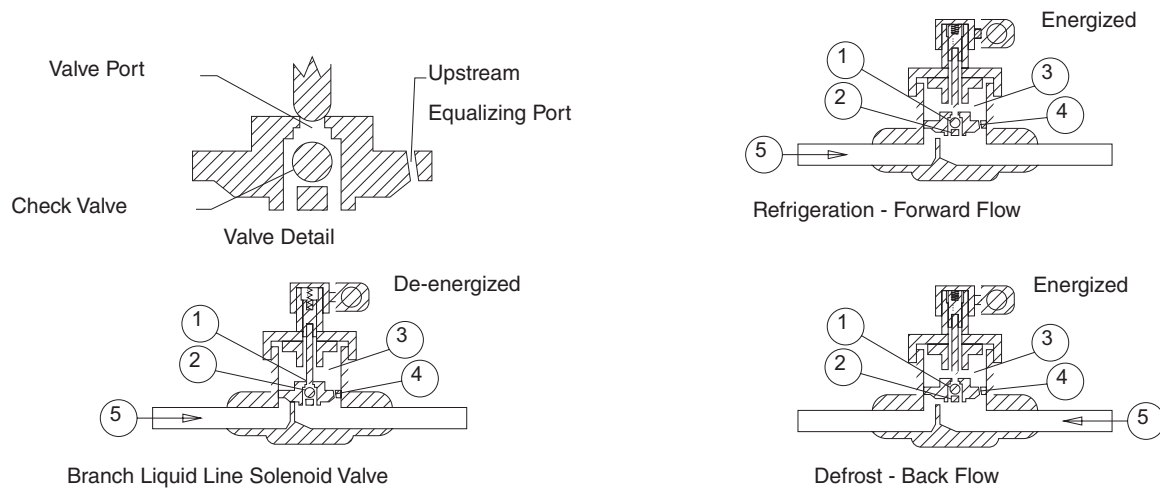

Hussmann’s racks will have a split condenser pump-out on the liquid drop leg that consists of a solenoid valve in series with a small orifice expansion valve. When the split condenser valve is also energized, this solenoid valve is energized allowing for a quick pump-out through the expansion valve and through the bleed port of the 3-way valve.

SURGE RECEIVER VALVES

When the refrigerant temperature returning from the condenser drops below its set point, the surge valve directs the flow of refrigerant around energized (open) directing refrigerant flow around the Receiver (Surge) in response to ambient subcooling obtained in the condenser.

HEAT RECLAIM VALVE

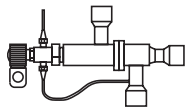

Heat Reclaim Valve

A 3-Way Heat Reclaim Valve directs the refrigerant to either the Condenser or a Heat Reclaim Coil. When the solenoid is de-energized the valve directs the refrigerant to the condenser. When the solenoid is energized the high pressure inlet is stopped and the passage between suction and valve chamber is open. When the solenoid is energized the suction outlet is stopped and the passage between high pressure and the valve chamber is open. Some manufacturers of the valve has a bleed port through the drive piston to the suction manifold. The bleed port provides a vent for fluids trapped in the heat reclaim circuits during normal operation.

THERMOSTATIC EXPANSION VALVE (TEV)

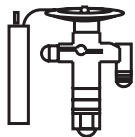
Thermostatic
Expansion Valve

Regulates refrigerant flow into the evaporator by responding to the temperature of superheated vapor at the outlet of the evaporator, and in some cases where a TEV is used with an external equalizer. The TEV also responds to the pressure at the outlet of the evaporator.

The TEV, located in the merchandiser, meters liquid refrigerant through its orifice to the low pressure side of the system where it absorbs heat from the coil causing the liquid to evaporate. An evaporator pressure regulator (EPR) may be used to control the evaporator temperature by preventing the evaporator pressure from dropping below a preset pressure. At critical locations along the refrigerant path, service valves or ball valves allow isolation of components.

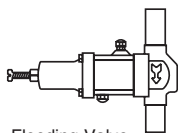

Flooding Valve

FLOODING VALVE AND RECEIVER PRESSURE REGULATING VALVE

The Flooding Valve and the Receiver Pressure Regulating Valve work together, the operation of one effects the operation of the other. The flooding valve responds to upstream pressure from the condenser. The receiver pressure regulating valve responds to downstream pressure in the receiver.

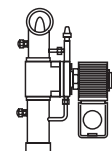
Pressure
Regulator Valve

The Pressure Regulator Valve responds to receiver pressure. If the receiver pressure drops below its set point, the valve opens, directing hot high pressure vapor to the receiver.

The Flooding Valve maintains head pressure in low ambient conditions by reducing the available condensing area. Restricting liquid refrigerant flow from the condenser, the flooding valve prevents the liquid refrigerant from leaving the condenser as fast as it is forming, so the condenser floods with its own condensate.

OIL PRESSURE REGULATION VALVE

The special oil pressure differential valve is used to reduce the high pressure in the combination oil separator and reservoir to a pressure slightly above the suction pressure to prevent overfeeding of the compressor float. The valve has an adjustment range of 3 to 30 psi differential pressure. Typically, this pressure should be approximately 20 to 25 psig above the suction pressure.

PRESSURE REGULATING RELIEF VALVE

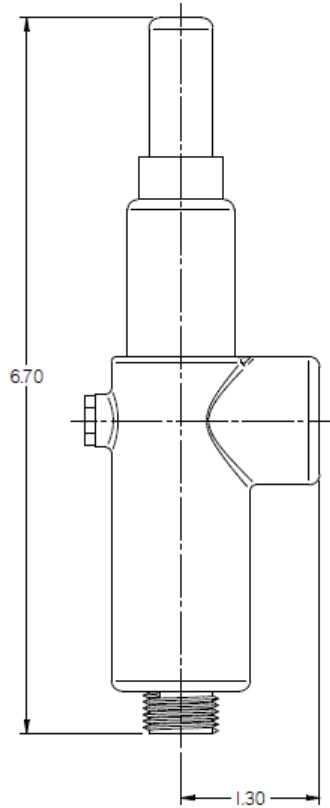

PRODUCT SPECIFICATIONS	
S852M-34MN0-34FN0-BR-BR-ET	REFERENCE: CO2 APPLICATION
	1. F85M-2 3/4-M X 3/4-F, BRASS
	ASME SECTION VIII DIV 1
	2. SPRING OPERATED SRV
	3. BRASS BODY AND TRIM
	4. ORIFICE AREA: .013 SQ INCHES
	5. INLET: 3/4" MNPT
	6. OUTLET: 3/4" FNPT
	7. SERVICE: CO2 VAPOR
	8. SET: 585 PSIG
	9. BLOWDOWN: 5%
	10. RELIEVING TEMP 28 DEG.F
11. SEAT: EPDM	
12. SEALS: TEFLON	
FUNCTIONAL TEST REPORT	

ONLY THE ITEM DESCRIBED ON THIS DOCUMENT, WHEN PROCURED FROM THE VENDOR (S) LISTED HEREON IS APPROVED BY HUSSMANN CORPORATION FOR USE IN APPLICATIONS SPECIFIED HEREON. A SUBSTITUTE ITEM SHALL NOT BE USED WITHOUT PRIOR APPROVAL BY HUSSMANN ENGINEERING. IDENTIFICATION OF THE APPROVED SOURCE (S) HEREON IS NOT TO BE CONSTRUED AS A GUARANTEE OF PRESENT OR CONTINUED AVAILABILITY AS A SOURCE OF SUPPLY FOR THE ITEMS DESCRIBED ON THE DOCUMENT.

CONTROL PANEL

The control panel contains all the necessary energy management components and motor controls factory-wired to the compressors. The interconnected compressors are cycled on and off, via low-pressure settings, by a central controller to match refrigeration capacity with load requirements.

Factory-wired control panel has:

- pre-wired distribution power block
- individual component circuit breakers and contactors
- compressor time delays
- color-coded wiring system

Items supplied separately for field installation:

- liquid dryer cores
- vibration isolation pads
- loose shipped items for accessories
- suction filter cores

OIL LEVEL REGULATORS

For any brand of oil level regulator to work accurately the unit and each compressor must be level. Both Sporlan and AC & R regulators may be damaged by over adjusting. Do not exceed 175 psig when testing to prevent damage to the floats. A sightglass filled with oil may indicate a damaged regulator. Before beginning adjusting, isolate the compressor by turning off its control circuit.

SPORLAN OIL LEVEL CONTROL OL-1 SERIES

The Sporlan Oil Level Regulator comes preset to maintain oil level at the center line of the sightglass. If there is any question as to the actual set point of the regulator, turn the adjustment stem counterclockwise until the top stop is reached. Then adjust the oil level down to the desired height by turning the stem clockwise. Each full turn will represent about .05 inches change in oil level. Do not exceed nine turns from the top, or the control may be damaged.

LIQUID/SUCTION HEAT EXCHANGER (OPTIONAL ON MEDIUM TEMP SYSTEM)

The low temperature liquid/suction heat exchanger transfers heat from the liquid to the vapor. This serves two functions. The primary function is to provide additional superheat to the vapor leaving the low temperature evaporators, ensuring no liquid floodback occurs to the compressors. It also cools the liquid below the saturated condition, ensuring 100% liquid is provided to the expansion valves. This also aids in oil flow to the compressors. This unit is sized to provide adequate heat exchange with minimal pressure drop especially on the vapor side.

EMERGENCY BACK-UP SYSTEMS (WHEN USED)

An emergency back-up system is offered as an option for a CO₂ system. This system consists of a small condensing unit and is typically fed from an emergency power source. This condensing unit provides cooling to an evaporator (plate-plate heat exchanger) to maintain the receiver temperature and pressure if the main high side system is off, such as during a power outage. This prevents pressure in the receiver from rising and venting.

Also, note that the back-up condensing unit will also be allowed to run if there is a problem maintaining the receiver pressure, or if all high side compressors are off for any reason, and it will further run based on an exercise schedule. To run, the liquid solenoid valve will be opened (energized, also from the emergency power source).

This unit should require the same refrigerant as the high side system, and standard start-up sequences should be followed. After start-up this unit should be tested and the TXV superheat checked. The operation should be checked by a simulating a power loss to the racks. Then, verify the CO₂ temperature/pressure is maintained.

FIELD-INSTALLED VALVES

All CO₂ system isolation valves have factory installed bypass check valves going back to a relief valve. There is no possibility of having an over-pressurization if any valve is closed. However, any field installed valves must also allow for bypass check valves.

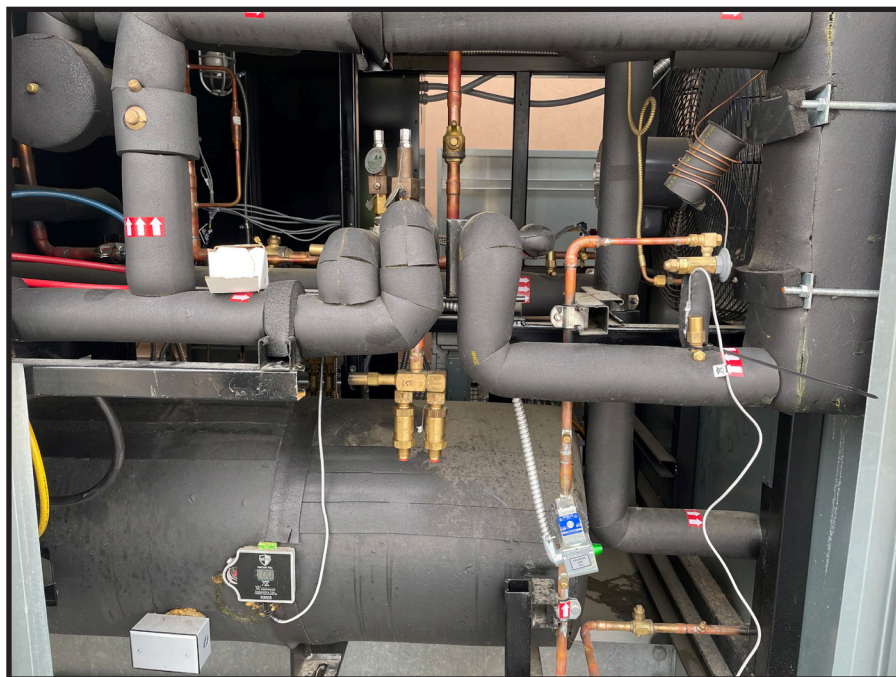

GLOSSARY OF TERMS

Refrigerant

A fluid used to freeze or chill (as food) for preservation

Primary Refrigerant

A fluid such as R404A used in a vapor compression system to cool a secondary coolant.

Secondary Coolant (Refrigerant)

A fluid such as Carbon Dioxide (CO₂) used to remove heat from cases and unit coolers and transfer the heat to the primary refrigerant through a heat exchanger. Secondary coolants used with these systems are for Low Temperature applications. The Low Temperature secondary coolant supply temperature is can range from -25° F to -15° F.

Compressor

This is a device that compresses the refrigerant from a low pressure low temperature gas to a high pressure high temperature gas and provides mass flow of refrigerant throughout the system.

Pressure Relief Valve

Add a new definition for Pressure Regulating Relief Valve:

These are set at a lower pressure than the main Pressure Relief Valves (585 psi) and are designed to vent CO₂ at a low rate through a small orifice. Piping should not be added to the outlet of this device to prevent the possibility of dry ice from forming and reducing the ability for this valve to vent. These are ASME calibrated to vent and are also designed to re-seat after the pressure has reduced to approximately 555 psi (5% blow-down). This valve should not be replaced if it vents, only if it is not able to reseat.

Cascade Heat Exchanger

This is a device built for efficient heat transfer between the primary refrigerant and secondary refrigerant. Heat exchangers may be classified according to their flow arrangement such as parallel flow, counter flow, or counter current design. For efficiency heat exchangers are designed to maximize the surface area of the wall between the two fluids while minimizing the resistance to fluid flow through the exchanger.

Liquid/Suction Heat Exchanger

This is a device built for efficient heat transfer between the liquid line and suction line of the primary refrigerant. This device also subcools the liquid refrigerant and aids in the complete evaporation of the suction gas.

Liquid / Vapor Separator

This is a vessel designed to separate the vapor and liquid phases of the secondary refrigerant. Gravity causes the liquid to settle to the bottom of the vessel where it is withdrawn to enter the inlet of the pump.

Electronic Expansion Valve

This is a device built to control the amount of superheat at the outlet of the primary side evaporator. In this system the Cascade Heat Exchanger is the evaporator for the primary refrigerant.

Liquid Filter Drier

This is a device designed to filter impurities and absorb moisture from the refrigerant in the liquid line.

NOTES:

ELECTRICAL INFORMATION

ELECTRICAL OVERVIEW

Custom wiring schematics are located on the doors of each rack. Racks are wired for 208-230/3/60 or 460/3/60. Other voltages are available upon request. The control circuit is typically 208VAC but racks can be ordered with a single point connection (optional). Refer to the serial plate located on the control panel to determine MCA MOPD.

Refer to merchandiser Data Sheets for electrical supply requirements for cases.

FIELD WIRING

Rack components are wired as completely as possible at the factory with all work completed in accordance with the National Electrical Code (NEC). All deviations required by governing electric codes will be the responsibility of the installer.

The lugs on the circuit breaker package in the compressor control panel are sized for copper wire only. All wiring must be in compliance with governing electrical codes.

For Remote Header Defrost Assembly:

To the defrost control panel, provide one 208V, 1PH and 15A branch circuit, or one 120V, 1PH and 15A branch circuit for control power only. One 208V 3PH branch circuit for electric defrost power, one communications circuit for electronic controller output/input boards. The 120V and 208V circuits may originate at the parallel rack or from a separate source.

Consult the store legend or electrical plans for each installation.

For 208-230/3/60 Compressor Units:

To each parallel rack compressor, provide one 208-230/3/60 branch circuit, one 120V or one 208V, 1PH and 15A circuit. Omit when single point connection kit is used.

Provide one 208-230/3/60 branch circuit to each remote air-cooled condenser. Dry contacts are made available upon request at the rack control panel. Contacts will close in alarm state. Contact rating is 10A at 208V. Alarm status may be configured through an electronic controller.

REQUIRED FIELD WIRE SIZE

Based on the full load amps of the system, select the largest connectable wire size from the table. (Based on no more than three wires in the wireway and 30°C environment per NEC.) Total Connected FLA Largest Connectable Wire:

140A (max)	00 per
248A (max)	350 mcm
408A (max)	2x (250 mcm) per
608A (max)	2x (500 mcm) per

Include control circuit amps if single point connection transformer option is used. 12A for 208V systems 6A for 460V systems (Refer to NEC for temperature duration factors.)

MERCHANDISER ELECTRICAL DATA

Technical data sheets are included with this manual. The data sheets provide merchandiser electrical data, electrical schematics, parts lists and performance data. Refer to the technical data sheets and merchandiser serial plate for electrical information.

MERCHANDISER FIELD WIRING

Field wiring must be sized for component amperes stamped on the serial plate. Actual ampere draw may be less than specified. Field wiring from the refrigeration control panel to the merchandisers is required for defrost termination thermostats and for optional refrigeration thermostats. When multiple merchandisers are on the same defrost circuit, the defrost termination thermostats are wired in series.

ELECTRICAL CONNECTIONS

All wiring must be in compliance with NEC and local codes. All electrical connections are to be made in the electrical wireway or *Handy Box*.

IDENTIFICATION OF WIRING

Leads for all electrical circuits are identified by colored plastic bands. These bands correspond to the *color code sticker* (shown below) located inside the merchandiser's wireway cover.

The defrost heaters, defrost termination thermostats and refrigeration thermostats on the wide island models are tagged with identification as being either front or rear merchandiser display section defrost and refrigeration controls.

ALWAYS CHECK THE SERIAL PLATE FOR COMPONENT AMPERES.

WIRING COLOR CODE

Leads for all electrical circuits are identified by a colored plastic band: neutral wire for each circuit has either White insulation or a White plastic sleeve in addition to the color band.

- | | | | |
|---------------------|--------------------------------------|---------------------|---|
| PINK | REFRIG. THERMOSTAT LOW TEMP. | ORANGE OR | |
| LIGHT BLUE. | REFRIG. THERMOSTAT NORM TEMP. | TAN | LIGHTS |
| DARK BLUE. | DEFROST TERM. THERMOSTAT | MAROON | RECEPTACLES |
| PURPLE | CONDENSATE HEATERS | YELLOW | DEFROST HEATERS 120V |
| BROWN | FAN MOTORS | RED | DEFROST HEATERS 208V |
| GREEN* | GROUND | | *EITHER COLORED SLEEVE OR COLORED INSULATION |

**ELECTRICIAN NOTE: Use copper conductor wire only.
CASE MUST BE GROUNDED**

ELECTRICAL DIAGRAMS

All electrical schematics reflect the standard ladder diagram. Electrical schematics are included with each rack. Please keep in mind all diagrams in this manual are only examples! Wiring may vary, refer to the diagram included with each rack. To focus on circuit logic the diagram may separate a relay coil and it's contacts. Electrical terminal connections are clearly numbered and aid in trouble shooting should a problem arise.

Unit Cooler Fan Wiring

See manufacturer's literature for wiring requirements. Evaporator mounted liquid line solenoid power for a liquid line solenoid can be picked up at the rack on terminals C and R for each respective circuit.

Cooler Door Switch Wiring

Check the store legend for door switch requirements. The switch must be mounted to the cooler door frame, and must be wired to control the field installed liquid line solenoid and the fan circuit. For Koolgas applications, install a check valve to bypass the liquid line solenoid valve.

COMPONENT WIRING GUIDELINES

Check the store legend for components requiring electrical circuits to either the panel, which may include:

- Remote alarm
- Electronic temperature probe
- Defrost termination thermostat
- Thermostat controlling a liquid line solenoid
- Satellite control
- Heat reclaim contact or 24V supply

All thermostat wires should be sized for rack control circuit breaker. Temperature sensor

wiring should refer to the controller manufacturer's literature. Check field wiring requirements for appropriate quantity of wires.

Sizing Wire and Overcurrent Protectors

Check the serial plate for minimum circuit ampacity (MCA) and maximum overcurrent protective devices (MOPD). Follow NEC guidelines.

Other Controls

Refer to the wiring schematics included with the rack, when other controls are used.

COMPRESSOR CONTROL

Each control panel is wired with independent compressor control circuits so any compressor can be electrically isolated without causing the other compressors to be shut down. A typical compressor control will consist of the following:

- Electrical control
- Switchback relay contacts (optional)
- Switchback time delay (optional)
- Low pressure switch
- High pressure switch
- Oil pressure switch
- Overload contact (if used)
- Contactor coil
- Demand cooling control (if used)
- Crankcase heater (optional)
- Lighted toggle switch

Terminal pins will be used between control points for easy testing and troubleshooting.

ELECTRONIC CONTROLLER

The electronic controller uses a suction transducer to “read” the suction manifold pressure. From this, sequence compressors on or off through a relay board to achieve the target suction pressure.

TIME DELAY

Automatic time delays are built into most electronic controllers. This helps avoid short cycling. A solid state time delay will be used for backup in the unlikely event of a electronic controller failure. The time delay will only be in the circuit during switch back, if the system uses switch back control.

If the system does not have optional switch back control then it will be wired in series with the operating controls. Awareness of time delays will reduce frustration and confusion when starting or troubleshooting the system.

PRESSURE SWITCHES

There are basically three pressure switches in the compressor control circuit. A low pressure switch is used to close the control circuit during high suction and open the circuit during low suction pressure. A high pressure switch is used to open the control circuit during a critical high discharge pressure state. The high pressure switch is available in automatic or manual reset. An oil pressure switch senses the supply oil pressure when the compressor is running.

If the oil pressure falls below the preset setting, the control circuit will open. Oil pressure switches are preset for 6.5 psig differential (Carlyle) and 9 psig differential (Copeland). The oil failure time delays are preset for 45 seconds (Carlyle) and 120 seconds (Copeland).

*For proper setting of switches see control settings section.

SWITCHBACK CONTROL (OPTIONAL)

During “normal” operation, the switchback relay will be de-energized allowing the electronic controller to be in full control. When the controller loses power or malfunctions, the switchback relay will energize which in turn will bypass the control power around the electronic controller and through the low pressure switch and time delay.

CRANKCASE HEATERS (OPTIONAL)

A crankcase heater is used to alleviate liquid migration to the compressor during off cycle periods. The crankcase heater is interlocked through the compressor contactor to be powered when the compressor is not running.

OIL FAILURE RELAY

This relay is used during an oil failure to jump the electronic controller relay. This will eliminate multiple alarms if the suction pressure drops and the compressor control point opens without the oil failure relay, the suction pressure would eventually rise causing another oil failure alarm.

CURRENT RELAY (OPTIONAL)

A current relay is wired in series with the oil failure control heater. This will prevent a false oil trip if the compressor circuit breaker should trip or if the compressor goes off on internal overload.

DEFROST CONTROLS

There are many types of defrost circuits and they are shown on the Defrost diagram in the rack. These circuits may be repeated in multiple and intermixed in any one store. Each control panel is wired with independent defrost control circuits so any circuit can be electrically isolated without causing the other circuits to be shut down.

A typical defrost circuit will consist of the following:

- Lighted toggle switch.
- Pins R and C for refrigeration power circuit.
- Pins D and C for defrost power circuit.
- N.C. contacts for refrigeration.
- N.O./N.C. contacts for defrost.
- Pins E and F for defrost termination. (Dry contact only)
- Pins T and B for temperature control thermostat (Dry contact only) or Temperature probes can be used for electronic controllers.

Refrigeration Mode:

During refrigeration, both the defrost point and refrigeration point are de-energized allowing L1 power to flow to the SV valve (Sorit or Liquid Solenoid). If case probes are used with the controller the refrigeration point will open when a system reaches proper operation temperature. Thus closing the refrigeration valve.

Defrost Mode:

The defrost point will energize opening power to the SV valve, refrigeration point. and closing power to the Kool/Hot gas valve (HGV) or defrost contactor (DC).

TEMPERATURE CONTROLS

Refrigeration Thermostat (Alternate)

If it is desired to have the refrigeration thermostat operate the branch liquid line solenoid on the compressor unit, wire it to the control panel in the following manner. Determine the system number from the store legend. The system will be on the suffix of the appropriate “T” and “B” terminals.

- a. Remove the jumper from the T and B terminal.
- b. Connect one thermostat wire to the T terminal.
- c. Connect the other thermostat wire to the B terminal.

Case Probe (Alternate)

If it is desired to monitor case temperature and operate a branch liquid line circuit, wire a case probe from the case to an analog point on the electronic controller. Provisions for case probes may be made from the field or factory. Refer to the controller manual for setup.

Defrost Termination Thermostat

For each system using defrost termination thermostats, run a two-wire control circuit from all termination thermostats (in series, one per case) to the E_ and F_ terminals in the control panel with a suffix corresponding to the system number.

Note: The defrost termination thermostat must supply a dry contact closure. An isolation relay must be used for a “hot” termination thermostat.

Master Defrost Valve

The master defrost valve is used during a hot/kool gas defrost cycle to create a reverse flow through the evaporator.

ALARM CONTROL

Alarm System

The rack basic alarm package includes alarms for:

- Oil Failure (each compressor)
- Phase Loss
- Low Liquid Level*
- High Suction*
- High Discharge
- Compressor Failure

*Time Delayed

A dry set of contacts are supplied to control a remote bell or other alarm device. These contacts are rated at 10.0 amps, 120V. An indicator light signifies what alarm condition has been activated.

Note: If an electronic rack controller is utilized, then the above alarms will be performed by the rack controller.

Ladder diagrams emphasize the circuit continuity and logic. They aid troubleshooting and testing by identifying point-to-point connections, and color coding rather than just physical location. A ladder diagram normally moves from left to right so the user can “read” the series of switches, relays, terminals and components that make up a circuit.

Alarm Control (Electronic)

When an Electronic Rack Controller is utilized all alarm functions are performed by the rack controller. High suction and high discharge pressures are “read” by transducers connected to the rack controller. The liquid level can either be a digital input (standard) or an analog type input.

The controller can display actual refrigerant level with the analog type (optional). Phase loss, oil failure, and the compressor failure alarms are connected to the rack controller through a digital input. An optional modem can be installed to allow the rack controller to call out any refrigeration alarms.

Alarm Systems

The following alarms are available for use with the parallel rack system:

1. Refrigerant Loss Alarm/Indicator:
An alarm trips if the refrigerant level in the receiver drops below a set level. This alarm automatically compensates for changes in liquid level occurring during heat reclaim.
2. Single Phase Protection: This shuts down the control circuit during single phasing of the power circuit; automatically resets when three phase power is restored.
3. Remote Alarm: In event of a power outage or any alarm condition, an alarm will sound at another location, such as a burglar alarm monitoring station or answering service.

INVERTER CONTROL

An inverter is used to vary the speed of a compressor which in turn varies the capacity of that compressor. With the ability to vary the capacity of a compressor, refrigeration requirements can be better matched to the load.

Unit Cooler Fan Wiring

Provide a 120/1/60 fused power supply for each cooler. (Check the store legend to see if 208-230/1/60 is required at this location.)

Evaporator Mounted Liquid Line Solenoid

Power for a liquid line solenoid in the merchandiser can be picked up from the fan circuit. (Check fan motor and solenoid voltages first.)

Cooler Door Switch Wiring

Check the store legend or electrical plans, for door switch kits. The switch must be mounted to the cooler door frame, and must be wired to control the field-installed liquid line solenoid and evaporator fans. Door switches are wired in series. For Koolgas applications, kit M116 includes a check valve to bypass the liquid line solenoid valve.

Sizing Wire and Overcurrent Protectors

Check the serial plate for Minimum Circuit Ampacity (MCA) and Maximum Overcurrent Protective Devices (MOPD). Follow NEC guidelines.

 **WARNING**

Intentionally venting or discharging CFC, HFC and HCFC refrigerant violates Federal Law. All CFC, HFC and HCFC refrigerants must be reclaimed and recycled in accordance with all state, federal and local laws.

6-8 ELECTRICAL INFORMATION

NOTES:

TECHNICAL SUPPORT AND COMPONENT REFERENCE DOCUMENTS

Hussmann Support 1-800-922-1919
 Parts may also be ordered at: parts.hussmann.com
 Call toll free: 1.855.487.7778

SQUARE D HOTLINE 888-SQUARED (888-778-2733)
 Tech Support Line. Level One provides product initial tech support and can connect the caller to Level 2, if required.

RDM - Refrigeration Control & Monitoring
 Technical Support
 +1 612 354 3923 (Option 2) usasupport@resourcedm.com



Parker Sporlan Literature Site



Kirwan / Delta Oil Switch



Mobile Apps for Emerson Product Support



Kirwan / Delta Oil Sensor



Sporlan MTW Valve



Temprite Coalescent Oil Separator



Sporlan Oil Line ROF Filter



Temprite 920 920R Installation



Sporlan EEV for Cascade



Standard Filter Install



Emerson OMB Oil Control



Temprite Clean up



Westermeyer Liquid Level



CPC



Parker/Sporlan A-8



Danfoss



Parker/ Sporlan A-9



VFD M-400 Parameter Sheet

SUPERMARKET EQUIPMENT

PRODUCT INFORMATION

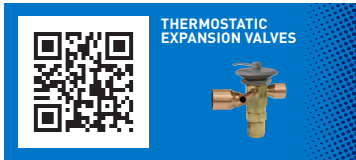

Form 5-422



Additional Sporlan Resources
SPORLAN APPS
SPORLAN SELECTION PROGRAM

www.sporlanonline.com



POP-OFF Valves

- **Mueller A15504-650** - Hussmann p/n 3084831
- **Flow Safe F85 basic model** 3/4" Hussmann p/n 3084834; 1/2" is p/n 3128103
- **Standard DX Mueller A18356-400** - Hussmann p/n 0417280
- **Bitzer Compressors** (come with the compressor), 34bar (435psi) Bitzer Part number 361100-34

MAINTENANCE & SERVICE

OIL CHANGES

Oil Changes should be accomplished following the procedure below: See Temprite step by step instructions for 920 & 920R Series Coalescent Oil Separators and the following page.

DAY 1

2 technicians, 8hrs (estimate, individual results may vary)

1. Hussmann suggest replacing the oil separator and suction filters on the first day. Place the suction line filter back in the suction shell to protect the suction line plate heat exchanger.
2. Proceed with a pump down and ensure that receiver does not exceed 80% of capacity, close liquid and suction ball valves.
3. Depressurize discharge and replaced discharge (Temprite) filter and suction filter, which can be done in a second step.

DAY 2

5 technicians, 6hrs (estimate, individual results may vary)

1. It is recommended that 1 person supervise the shutdown for the ball valve, compressor and watch the pressure.
2. Evaluate the amount of compressors running on the medium temperature.
3. If possible, drain the oil on the first half of the compressors on medium temperature and fill those with new oil ready to run.
4. Lower the oil level in the oil reservoir by about 80-90 %.
5. When these steps are completed, pump the medium temperature system partially to 80% of the tank, always have a gauge on tank pressure.
6. If you have a back up condensing unie with plate heat exchangers at the tank, start manually to keep the pressure as low as possible.
7. Close all suction ball valves on all low and medium circuits as well as liquid ball valves (or solenoids).
8. Turn all compressors off.
9. Finish draining the oil reservoir and fill it as quickly as possible, if you have an electric oil pump that will help to shorten the time.
10. Two other technicians can drain the oil in the low temp CO₂ compressors. Follow typical DX practices for the medium temperature compressors.
11. When the oil reservoir is full and ready to start again, the medium temperature load must be gradually moved to the compressors, the oil of which has been drained and ready to start again.
12. Restart the low temperatures gradually.
13. The oil used for oil change is the POE RL68HB for Copeland and BSE85K for Bitzer.

* The time was based on an average dual temp rack, 8 compressors on medium temp and 3 compressors on low temp.



**Installation Instructions for All
920 & 920R Series Coalescent Oil Separators: Accessible**

920 and 920R Series coalescent oil separators have a factory-installed Temprite Standard Filter. A second supplied filter is to be used as a replacement in 24 to 48 hours. Remember: Temprite Standard Filters will pick up all dirt and particulates down to 0.3 microns. Typical filters only catch 50 microns or larger. Follow all EPA guidelines and industry practices.

1. Locate the separator in a warm, draft-free area, or wrap separator with insulation. An electrical heater may be required for outdoor installation.
2. If using a mechanical Oil Level Control with an R model separator, a pressure-reducing valve is required on multiplexed compressors (Temprite A-7 Valve). Two (2) or more A-7 valves are required with split suction group systems.
3. Install the separator in a vertical position, close to the compressor, in between compressor and condenser, upstream (before) any bypass piping, i.e., hot gas defrost, heat reclaim.
4. Special consideration should be given to the location to not impede future filter replacement or service.
5. Clamp and support the separator and piping properly to minimize vibration.
6. The connections on the oil separator must be the same size as (or larger than) the discharge line size.
7. Install pressure taps in these lines for reading pressure drop across the separator or for installing a Temprite Pressure Differential Indicator (PDI).
8. Charge the separator with the recommended amount of oil through the outlet connection before installing or starting the system. See label, or fill to the top sight glass on R models.
9. Keep the separator cool when brazing.
10. If the oil separator is lower than the condenser, keep liquid refrigerant out of the separator by taking precautions such as installing a check valve in the discharge line after the separator, or installing an inverted trap, etc.
11. Install solenoid in the oil return line for pump-down systems.
12. For retrofitted systems, you may want to start the system with a Clean-Up® Filter instead of a Standard Filter.
13. Frequently check oil level and pressure drop across the separator on new installations or retrofits.
14. Replace the filter after an initial 24 to 48 hours of operation or if the pressure drop across the separator exceeds 13 PSID/0.9 bar.
15. Replace the filter if dirt loading causes a pressure drop of 13 PSID/0.9 bar differential across the separator.
16. After a compressor burn-out, use a Temprite Clean-Up® Filter. Monitor the pressure drop. Install a Temprite Standard Filter when the pressure drop across the separator stays below 13 PSID/0.9 bar.
17. For "R" models, the oil level should be maintained between the two (2) sight glasses.

For translations of these instructions, go to our website: [click here](#) or scan the QR code.



Questions? Call 1.800.552.9300 or 1.630.293.5910 or email us at temprite@temprite.com

www.temprite.com

COMPRESSOR REPLACEMENT

Since each machine room or rooftop unit tends to be unique, plan carefully as to how you will move the compressor without harming personnel, equipment or the building. Before beginning removal of an old compressor make replacement unit ready to install:

1. **Verify replacement** compressor electrical requirements, refrigerant, application, capacity, piping hookup location and design suction and discharge gaskets.
2. **Mounting requirements:** Have compressor in an easily accessible position, uncrated and unbolted from shipping pallets.
3. **Disconnect electrical supply:** Turn off motor and control panel power supplies to the Rack. Turn off control circuit and open all compressor circuit breakers. Tag and remove electrical wires and conduit from the compressor.
4. **Isolate compressor from rack:** Front seat suction and discharge service valves. Close oil supply and equalizing lines. Bleed compressor pressure through both discharge and suction access ports into an approved recovery vessel.
5. **Remove oil supply and equalizing lines.** Remove externally mounted components which will be re-used on the replacement compressor. Plug holes to compressor manufacturer's specifications.
6. Remove bolts from suction and discharge service valves.
7. **Remove mounting bolts:** When moving the compressor, use a come-along, hoist or hydraulic lift to carry the weight.
 - Do not use the rack piping or panel to support a hoist or come-along.
 - Do not use ceiling trusses to support a hoist or come-along.

The rear support channel on the rack or a properly constructed ceiling rail may be used to support a hoist or come-along. To make hookup and lifting easier, an eye bolt may be installed in the rear top of the compressor head.

If a compressor removal table is used, slide the compressor fully on to the table, then roll table to overhead hoist or hydraulic lift area. When the old compressor has been removed, clean the suction and discharge service valve gasket surfaces to shiny metal. Clean the gasket surfaces on the new compressor to shiny metal. Be careful not to groove or round the surfaces. Gasket surfaces must be clean to prevent leaking.

Install the new compressor in reverse order of removal. Do not open the new compressor to the system until after it has been leak tested and triple evacuated.

Note: Oil level regulator sight glasses are designed to provide a hermetic seal when internally pressurized. Some leaking may occur when a deep vacuum is pulled.

8-4 MAINTENANCE AND SERVICE

Cleaning the Turba-Shed (Oil Separator)

Should the oil separator require cleaning, first shut down the system. Isolate the oil separator and bleed off pressure into an approved recovery vessel. Remove the top and bottom sight glasses and the oil supply line. With a clean, dry, regulated pressure source like nitrogen, blow out any sludge or dirt. Install the sightglasses using new o-rings.

Parker Number 2-23,
Compound 557 Precision Rubber, number 023,
Compound 2337

Leak test, evacuate, and charge with fresh oil refer to legend for oil type. Open valves closed to isolate the oil system and bring the rack back on line.

Replacing Drier and Filter Cores:

Shut down the system. Isolate the core to be replaced and bleed off pressure into an approved recovery vessel. Open housing, replace core and close up. Pressurize, leak test and bring back into line.

WINTER CONDENSING PRESSURE CONTROLS

Five methods are used to control condensing pressure during cold weather operation.

1. Flooding valves must be applied to the compressor unit when winter temperatures are expected.
2. Temperature Control: Fans are thermostatically controlled and cycled accordingly to outside temperature. Can be applied to single circuited condensers.
3. Thermal Fantrol: Used with multi-circuited condensers. Fans are cycled according to outside temperatures.
4. Split Condensers (factory or field installed): Used on dual circuit condenser with or without heat reclaim, where a four-way solenoid valve (controlled by ambient sensing temperature control or pressure control) activates to cut off one half of the condensers. Field-installed situations will require double discharge and double condenser leg return piping.

GENERAL MAINTENANCE

Regular inspection and upkeep is critical to operation of the rack. Because of the numerous options and accessories that are unique to each store, it is impossible to list all of the maintenance guidance for individual systems.

Maintenance must be performed by a well qualified technician to diagnose and prevent problems before they may occur. The information below is a general guideline.

Recommended service intervals in your area may vary depending on the operating environment and equipment used. Contact your Husmann representative for further information.

Generally, the following items should be checked on a weekly basis:

- System Pressures
- Main Power Voltage
- Oil Levels
- Refrigerant Charge

Generally, the following items should be checked on a monthly basis:

- System pressures
- System leak tests
- All filters and drier cores
- Insulation, conduit, electrical boxes and control panels
- Secondary systems, and accessories
- Fan motors, contactors and electrical connections
- Check for tightness of fittings, fan blades and motor mounts

Generally, the following items should be checked on a quarterly basis:

Investigate operating conditions for the following:

- Suction, liquid, and discharge pressures and temperatures
- Sub-cooling, superheat and ambient temperatures
- Safety controls, operating controls and alarms
- Amperage coming from compressors

Each year, check the following:

- Clean the condenser coil
- Straighten or replace all fan blades
- Change the filter drier and suction cores
- Get an oil sample and determine the quality and change if required

DRIER AND FILTER CORES REPLACEMENT

Replacing Drier and Filter Cores Shut down the system. Isolate the core to be replaced and bleed off pressure into an approved recovery vessel. Open housing, replace core and close up. Pressurize, leak test and bring back into line.

HUSSMANN[®]

To obtain warranty information
or other support, contact your Hussmann representative.

Please include the model and
serial number of the product.