



Installation, Operation, and Service Manual

Open Island and Wall Display Case

Low and Medium Temperature

P/N 0467434 Rev R
February 2026

Models Covered
F, FG, FI, FIG, FN, FNG, FW,
FWG, FWE, FWEG, FWGH,
FWEHG

Certifications



WARNING:

If the information in these instructions are not followed exactly, a fire or explosion may result, causing property damage, personal injury, or death. Installation and service must be performed by a qualified installer or service agency.

READ THE ENTIRE MANUAL BEFORE INSTALLING OR USING THIS EQUIPMENT.

The equipment can be configured to use a variety of refrigerants during the ordering process. Different refrigerants have unique characteristics to be aware of, including the mild flammability of A2L refrigerants and potential toxicity of R-744 (CO₂) in high concentrations. If a leak is present or suspected, do not allow untrained personnel to attempt to find the cause and observe all warnings contained within this document. No open flames, cigarettes, or other possible sources of ignition should be used inside or in the vicinity of equipment containing flammable refrigerants.

Equipment is limited to use in an altitude of 6,562 ft (2 km) or less.

FAILURE TO ABIDE BY THIS WARNING COULD RESULT IN AN EXPLOSION, DEATH, INJURY, AND PROPERTY DAMAGE.

We reserve the right to change or revise specifications and product design in connection with any feature of our products. Such changes do not entitle the buyer to corresponding changes, improvements, additions or replacements for equipment previously sold or shipped.

Excel Open Island and Wall

Table of Contents

User Safety and Product Information	3	Load Limits	50
Legal Disclaimer	3	Thermometer	51
ANSI Z535.5 Definitions	3	Offsetting Bumper	52
Proposition 65	3	Offsetting Plastic Top Rail	56
Serial Label Location	4	Installing Splashguards	58
UL Listing	4	Maintenance and Service	61
NSF Listing	4	Checks and Repairs for A2L Equipment	61
Climate Class and Ambient Conditions	4	Checks and Repairs for R-744 (CO ₂) Equipped Equipment	62
Federal / State Regulation	4	Checks and Repairs for All Equipment	62
Additional Important Symbols	4	Care and Cleaning	63
General Safety Instructions	5	Troubleshooting	68
Before Working with All Refrigerant Types	6	Refrigerant Removal, Evacuation, and Recovery	69
Before Working with R-744 (CO ₂) Refrigerant	9	Leak Detection (all refrigerants)	70
Before Working with A2L Refrigerant	15	A2L Leak Detection Sensor Service and Mitigation	71
A2L Refrigerant Detection System Overview	17	Component Replacement	77
Model Description	18	Decommissioning	93
Hussmann Product Control	18	Decommissioning Process	93
Installation Information	19	Warranty	94
Equipment Inspection / Shipping Damage	19	Revision History	94
Unloading, Moving, and Transporting Case Location	19		
Minimum Room Floor Area (A2L only)	20		
Leveling Case	22		
Case Joining	23		
Installing Splashguard Brackets	30		
Replacing Interior Panels and Discharge Air Louvers	30		
Installing Flue Glass	31		
Installing Partitions	31		
Installing End Assemblies	32		
Piping Overview	33		
CO ₂ Piping	33		
Additional Piping Installation Requirements	35		
Line Connection Sizes	36		
Waste Outlet/Drain Line	36		
Refrigerant Piping	36		
Twin-temperature Operation	40		
Thermostats	40		
Waste Outlet / Drain Line	41		
Installing Drip Piping	42		
Electrical Information	44		
Field Wiring	44		
Refrigerant Charging Procedure	45		
Pumped Liquid R-744 (CO ₂) Start-Up Checklist	46		
Pumped Liquid R-744 (CO ₂) Operation	47		
Safety Shut-Off Valves (A2L only)	49		
Pumped Liquid R-744 (CO ₂) Case Inlet Solenoid Valve	50		

Excel Open Island and Wall

User Safety and Product Information

Legal Disclaimer

Review all safety warnings on the case and in this manual before attempting start-up. Hussmann shall not be liable for any repair or replacement made without the written consent of Hussmann, or when the product is installed or operated in a manner contrary to the printed instructions covering installation and service which accompanied such product. Please note that failure to follow the instructions in this document may void your factory warranty.

As used herein, “appliance”, “unit”, and “equipment” each refer to case family/name unless otherwise stated or contextualized and “system” means a set of things working together as parts of an interconnecting network.

ANSI Z535.5 Definitions

The definitions below are used to clarify the magnitude and urgency of harm and damage, considering problems arising from misuse. Relative to their potential danger, the definitions are divided into five parts according to ANSI Z535 Series.



DANGER indicates a hazardous situation which, if not avoided, will result in death or serious injury.



WARNING indicates a hazardous situation which, if not avoided, could result in death or serious injury.



CAUTION indicates a hazardous situation which, if not avoided, could result in minor or moderate injury.



NOTICE is used to address practices not related to personal injury.



SAFETY INSTRUCTIONS (or equivalent) signs indicate specific safety-related instructions or procedures.

Proposition 65



This warning does not mean that Hussmann products will cause cancer or reproductive harm, or is in violation of any product-safety standards or requirements. As clarified by the California State Government, Proposition 65 can be considered more of a ‘right-to-know’ law than a pure product safety law. When used as designed, Hussmann believes that our products are not harmful. We provide the Proposition 65 warning to stay in compliance with California State law. It is your responsibility to provide accurate Proposition 65 warning labels to your customers when necessary. For more information on Proposition 65, please visit the California State Government website.

Excel Open Island and Wall

User Safety and Product Information

Serial Label Location

The serial label contains all pertinent information such as model, serial number, amperage rating, refrigerant type, and other important installation and safety information. The front of a wide island merchandiser is readily identified by the location of the serial plate affixed to the inside of the left front assembly. Since all electrical and refrigeration connections will be made at the front side, the fronts will need to be positioned according to the store plan layout.



A secondary serial number sticker is put on the exterior nosing on the discharge side. It provides the model, serial number and manufacture date. The serial label also contains all pertinent information such as model, serial number, amperage rating, refrigerant type, and other important installation and safety information.

UL Listing

These merchandisers are manufactured to meet ANSI / UL 60335-2-89 and CSA C22.2 standard requirements for safety. Proper installation is required to maintain this listing. This appliance is to be installed in accordance with the Safety Standard for Refrigeration Systems, ANSI/ASHRAE 15.

NSF Listing

These merchandisers are manufactured to meet ANSI / NSF-7 standard requirements for sanitation. Proper installation is required to maintain this listing.

Climate Class and Ambient Conditions

The test room climate class for this appliance is Climate Class 8. Climate Class 8 means the equipment has been tested for maximum ambient of 75° F (23.9° C) dry bulb and 55% relative humidity.

Ambient conditions that equipment is designed for may exceed 75° F (23.9° C) and 55% relative humidity in some cases. Consult the labeling on the equipment for the maximum ambient temperature and humidity in which the equipment can be installed. Do not exceed the listed ambient conditions.

Federal / State Regulation

These merchandisers, at the time they are manufactured, meet all federal and state/provincial regulations. Proper installation is required to ensure these standards are maintained. Near the serial label, each case carries a label identifying the environment (temperature and relative humidity) in which the case was designed to be used.

Additional Important Symbols

The symbols below indicate specific types of information on the equipment.



Risk of fire due to flammable material and/or refrigerant being present

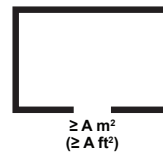

Minimum Room Floor Area



High Pressure



Grounding Connection Location

Excel Open Island and Wall

User Safety and Product Information

General Safety Instructions

SAFETY INSTRUCTIONS

This manual was written in accordance with originally prescribed equipment that is subject to change. Hussmann reserves the right to change or revise specifications and product design in connection with any feature of our products.

Personal Protection Equipment (PPE) is required. Wear safety glasses, gloves, protective boots or shoes, long pants, and a long-sleeve shirt when working with this equipment and while handling glass.



The safety of our customers and employees is paramount. The precautions and procedures described in this manual are intended as general methods for safe use of this equipment. Please be sure to comply with the precautions described in this manual to protect you and others from possible harm. Always follow OSHA standards for safety.

Only qualified personnel should install and service this equipment. Personal Protection Equipment (PPE) is required. Wear safety glasses, gloves, protective boots or shoes, long pants, and a long-sleeve shirt when working with this equipment and while handling glass.

Observe the refrigerant type the equipment is designed to work with and any and all precautions on tags, stickers, labels and literature provided and referenced for this equipment. Use only Hussmann approved parts approved through the Hussmann Performance Parts Website. Verify that all repair parts are identical models to the ones they are replacing. Do not substitute parts such as motors, switches, relays, heaters, compressors, power supplies, or solenoids. Read all safety information regarding the safe handling of refrigerant and refrigerant oil, including the Material Safety Data Sheet. MSDS sheets can be obtained from your refrigerant supplier. Service is to be performed by factory-authorized service personnel, so as to minimize the risk of possible injury due to incorrect parts or improper service.

Contractors must strictly adhere to specifications provided by the Engineer of Record (EOR), as well as US EPA regulations, OSHA regulations, and all other federal, state, and local codes. There are numerous hazards, not limited to, but including: burns due to high temperatures or refrigerant flammability, high pressures, toxic substances, electrical arcs and shocks, very heavy equipment with specific lift points and structural constraints, public safety, noise, and possible environmental damage.

Excel Open Island and Wall

User Safety and Product Information

WARNING

Before Working with All Refrigerant Types

The following apply to ALL REFRIGERANT TYPES. Refrigerant specific warnings and safety information are present in the following sections. Do not attempt to install, service, or perform maintenance on any equipment without reading and understanding ALL applicable warnings related to the equipment.

READ THE ENTIRE MANUAL AND ALL WARNINGS BEFORE INSTALLING OR USING THIS EQUIPMENT.

- Installation and use of this appliance includes numerous hazards, not limited to, but including: burns due to high temperatures, high pressures, toxic substances, electrical arcs and shocks, very heavy equipment with specific lift points and structural constraints, food and product damage or contamination, public safety, noise, and possible environmental damage.
- This appliance shall only be connected to another appliance suitable for the same refrigerant.
- Be aware that refrigerants may not contain an odour.
- Excessive ambient conditions may cause condensation and sweating on doors. Facility operators are responsible for monitoring doors and floor conditions and ensuring the safety of all persons present. Installation and service must be performed by a qualified installer or service agency only as recommended by the manufacturer.
- If a leak is present or even suspected, do not allow untrained personnel to attempt to find the cause.
- A hand-held leak detector (“sniffer”) will be used before any repair and/or maintenance.
- **WARNING:** Keep clear of obstruction, all ventilation openings in the appliance enclosure or in the structure for build-in.
- **WARNING:** Do not use mechanical devices or other means to accelerate the defrosting process, other than those recommended by the manufacturer.
- **WARNING:** Do not damage the refrigerating circuit.
- **WARNING:** Do not use electrical appliances inside the food/ice storage compartments unless they are the type recommended by the manufacturer.
- Do not use any means to clean, other than those recommended by the manufacturer.
- Do not use means to accelerate the defrosting process or to clean, other than those recommended by the manufacturer.
- The appliance shall be stored in a room without continuously operating ignition sources (for example: open flames, an operating gas appliance or an operating electric heater).
- Do not pierce or burn refrigerant piping.
- Do not store items or flammable materials atop the unit. Do not walk on case.
- Do not store explosive substances, such as aerosol cans with flammable propellant, in this appliance.
- This appliance is not intended for use by persons (including children) with reduced physical, sensory or mental capabilities, or lack of experience and knowledge, unless they have been given supervision or instruction concerning use of the appliance by a person responsible for their safety.
- Children should be supervised to ensure that they do not play with the appliance.

Excel Open Island and Wall

User Safety and Product Information

WARNING

- Check that cabling will not be subject to wear, corrosion, excessive pressure, vibration, sharp edges, or any other adverse environmental effects. The check shall also take into account the effects of aging or continual vibration from sources such as compressors or fans.
- Any insulation shall be suitable for use with the material being insulated.
- Protection devices, piping, and fittings shall be protected as far as possible against adverse environmental effects, for example, the danger of water collecting and freezing in relief pipes or the accumulation of dirt and debris.
- Piping material, pipe routing, and installation shall include protection from physical damage in operation and service, and be in compliance with national and local codes and standards, such as ANSI/ASHRAE 15, IAPMO Uniform Mechanical Code, ICC International Mechanical Code, or CSA B52. All field joints shall be accessible for inspection prior to being covered or enclosed. Mechanical connections made in accordance shall be accessible for maintenance purposes.
- The installation of pipe-work shall be kept to a minimum.
- Mechanical connections made in accordance shall be accessible for maintenance purposes.
- Provision shall be made for expansion and contraction of long runs of piping.
- Piping in refrigeration systems shall be so designed and installed to minimize the likelihood of hydraulic shock damaging the system.
- Flexible pipe elements shall be protected against mechanical damage, excessive stress by torsion, or other forces, and that they should be checked for mechanical damage annually.
- Precautions shall be taken to avoid excessive vibration or pulsation of the refrigerant piping.
- LOCK OUT / TAG OUT — To avoid serious injury or death from electrical shock, always disconnect the electrical power at the main disconnect when servicing or replacing any electrical component. This includes, but is not limited to, such items as doors, lights, fans, heaters, and thermostats.
- To reduce the risk of fire, electrical shock or injury when cleaning this merchandiser:
 - Unplug the merchandiser before cleaning.
 - Keep all liquids away from electrical and electronic components.
- Merchandiser must be grounded. All wiring must be in compliance with NEC and local codes.
- The appliance shall not be installed in public corridors or lobbies.
- All servicing of this appliance shall be performed only as recommended in this manual.
- Particular attention shall be paid to the following to ensure that by working on electrical components, the casing is not altered in such a way that the level of protection is affected. This shall include damage to cables, excessive number of connections, terminals not made to original specification, damage to seals, incorrect fitting of glands, etc.
- Ensure that the apparatus is mounted securely.
- Ensure that seals or sealing materials have not degraded to the point that they no longer serve the purpose of preventing the ingress of flammable atmospheres. Replacement parts shall be in accordance with the manufacturer's specifications.

Excel Open Island and Wall

User Safety and Product Information

WARNING

- Where electrical components are being changed, they shall be fit for the purpose and to the correct specification. At all times, the manufacturer's maintenance and service guidelines shall be followed. If in doubt, consult the manufacturer's technical department for assistance.
- During repairs to sealed components, all electrical supplies shall be disconnected from the equipment being worked upon prior to any removal of sealed covers, etc. If it is absolutely necessary to have an electrical supply to equipment during servicing, then a permanently operating form of leak detection shall be located at the most critical point to warn of a potentially hazardous situation.
- Component parts shall be replaced with like components, and servicing shall be done by qualified service personnel only.
- Do not apply any permanent inductive or capacitance loads to the circuit without ensuring that this will not exceed the permissible voltage and current permitted for the equipment in use.
- After completion of field piping for split systems, the field pipework shall be pressure tested with an inert gas and then vacuum tested prior to refrigerant charging, according to the following requirements:
 1. The minimum test pressure for the low side of the system shall be the low side design pressure and the minimum test pressure for the high side of the system shall be the high side design pressure, unless the high side of the system cannot be isolated from the low side of the system in which case the entire system shall be pressure tested to the low side design pressure.
 2. The test pressure after removal of pressure source shall be maintained for at least 1 hour with no decrease of pressure indicated by the test gauge, with test gauge resolution not exceeding 5% of the test pressure.
 3. During the evacuation test, after achieving a vacuum level specified in the manual or less, the refrigeration system shall be isolated from the vacuum pump and the pressure shall not rise above 1,500 microns within 10 min. The vacuum pressure level shall be specified in the manual, and shall be the lessor of 500 microns or the value required for compliance with national and local codes and standards, which may vary between residential, commercial, and industrial buildings.
- Solenoid valves of any kind, including safety shut-off valves, shall be correctly positioned in the piping to avoid hydraulic shock.
- Solenoid valves of any kind, including safety shut-off valves, shall not block in liquid refrigerant unless adequate relief is provided to the refrigerant system low pressure side.

FAILURE TO ABIDE BY THESE WARNINGS COULD RESULT IN AN EXPLOSION, DEATH, INJURY, AND PROPERTY DAMAGE. READ ALL WARNINGS PRIOR TO INSTALLING, PERFORMING MAINTENANCE, OR SERVICING THE EQUIPMENT IN ANY WAY.

Excel Open Island and Wall

User Safety and Product Information

WARNING

Before Working with R-744 (CO₂) Refrigerant

- **WARNING:** The refrigeration system is under high pressure. Do not tamper with it. Contact qualified service personnel before disposal.
- R-744 (CO₂) systems have similar safety concerns with all conventional refrigerants, in that it displaces oxygen, is heavier than air and will concentrate closer to the floor if there is a system leak. R-744 should be monitored for leaks similar to other refrigerants.
- If the refrigeration system is de-energized, venting of the R-744 through the pressure regulating relief valves on the refrigeration system can occur. In such cases, the system might need to be recharged with R-744, but in any case, the pressure regulating relief valve(s) shall not be defeated or capped. The relief setting shall not be altered.
- A sufficient number of pressure relief and pressure regulating relief valves might need to be provided based on the system capacity and located such that no stop valve is provided between the relief valves and the parts or section of the system being protected.
- A pressure relief device shall be installed in the high-pressure side of the refrigeration system between the motor-compressor and the gas cooler. There shall be no shut off devices or other components except piping between the motor-compressor and the pressure relief device that could introduce a pressure drop.
- The pressure relief device shall be mounted so that any refrigerant released from the system during its operation cannot cause harm to the user of the appliance. The aperture shall be located so that it is unlikely to be obstructed in normal use.
- The installed pressure relief device shall have no provisions for setting by the end user.
- The pressure setting of the installed pressure relief device shall be no higher than the design pressure of the high-pressure side.
- Confirm operation of leak detectors (e.g., by exhaling near the sensor), audible / visible alarms, and machine room ventilation before operation.
- Ventilate adjacent enclosed areas to prevent the formation of dangerous concentrations of carbon dioxide.
- Avoid contact of the skin or eyes with solid carbon dioxide (dry ice) or objects cooled by solid carbon dioxide.
- Additional information on the safe use and handling of carbon dioxide can be found in Standards from the Compressed Gas Association Standard (www.cganet.com).
- The following checks shall be applied to installations:
 - a. The actual REFRIGERANT CHARGE is in accordance with the room size within which the refrigerant containing parts are installed.
 - b. The ventilation machinery and outlets are operating adequately and are not obstructed.
 - c. If an indirect refrigerating circuit is being used, the secondary circuit shall be checked for the presence of refrigerant.
 - d. Marking to the equipment continues to be visible and legible. Markings and signs that are illegible shall be corrected.
 - e. Refrigerating pipe or components are installed in a position where they are unlikely to be exposed to any substance which may corrode refrigerant containing components, unless the components are constructed of materials which are inherently resistant to being corroded or are suitably protected against being so corroded.

Excel Open Island and Wall

User Safety and Product Information

WARNING

- Replacement parts must be compatible with the specific equipment’s maximum design pressure as shown on the equipment labeling. For example, if the equipment has been designed to meet 1,305 psig (90 bar) maximum design pressure then any replacement part must be 1,305 psig (90 bar) compatible.
- Never apply heat directly to piping containing CO₂. Rapid thermal expansion of CO₂ can cause the pipe to burst.
- Pressure transducers / leak detectors / warning lights / sounders/buzzers / and plant room ventilation must all be operational prior to charging with CO₂.
- Pressure relief devices / check valves must be located anywhere that liquid CO₂ can be trapped. Trapped CO₂ at -40° F (-40° C) will double in volume if allowed to rise to 86° F (30° C).
- Under no circumstances add Schrader valves to or remove Schrader valves from the system.
- Observe all warnings and labels on the unit being installed or serviced such as the one below indicating high pressure.



- All refrigeration servicing must be completed by a certified refrigeration installation professional, and all tubing and components must be qualified for R-744 (CO₂) applications, with a minimum design pressure that matches the system requirements listed on the equipment (e.g., 1,305 psig [90 bar]).
- Inspect all components prior to installation to ensure that they are free from defects or foreign materials and to confirm that they comply with all pressure and temperature ratings.

Asphyxiation

- R-744 is odorless, heavier than air, and is an asphyxiant gas. If sensor reading is maxed out or non-responsive assume an unsafe level of CO₂ and ventilate the room prior to entering.
- Practical limit of R-744 is 0.006 lb/ft³ (56,000 ppm).
- Personnel including rescue workers should not enter areas in which the carbon-dioxide content exceeds 3% (30,000 ppm) by measurement unless wearing an SCBA or supplied-air respirator.
- A leak of R-744 could result in a concentration exceeding the practical limit in an enclosed, occupied space such as a cold room. Precautions must be taken to prevent asphyxiation. These include the use of permanent leak detection, which activates an alarm in the event of a leak.
- The practical limit is defined in ASHRAE 34 but may vary depending on regional regulations. The table below summarizes the effect of R-744 at various concentrations in the air.

PPM of R-744 (CO ₂)	Effects
442	concentration in atmosphere
5,000	long-term exposure limit (8 hours)
15,000	short-term exposure limit (10 minutes)
30,000	discomfort, breathing difficulties, headache, dizziness, etc.
100,000	loss of consciousness, followed by death
300,000	quick and immediate death

Excel Open Island and Wall

User Safety and Product Information

CO₂ Quality

- CO₂ that is purchased for use in refrigeration systems should be of a purity level high enough to prevent accumulation of non-condensable gases and moisture. A build-up of these gases can block small orifices (such as expansion valves) or lead to high discharge pressure, reducing operation or causing the system to become inoperable.
- CO₂ is commercially available at several different purity levels. The common names and percent purity are listed below. Hussmann recommends using “Refrigeration Grade” (99.99% purity) CO₂.
- Mixing of higher purity grades of CO₂ is acceptable. Lower grades of CO₂ contain higher levels of contaminants and water and will decrease system performance. Higher levels of moisture may react with the CO₂ and form carbonic acid that can degrade component integrity. Hussmann recommends keeping enough refrigeration grade CO₂ on-site to charge the system.
- Medical grade CO₂ should not be used, due to the outlet pressure regulators typically present on tanks.
- Bone-Dry grade is the minimum acceptable purity to ensure proper operation of the equipment and is pure enough to technically prevent accumulation of non-condensable gases in the system.
- R-744 (CO₂) purity:

R-744 (CO ₂) Grade	Purity
Industrial and Medical Grade	99.5%
Bone Dry (minimum acceptable)	99.8%
Anaerobic Grade	99.9%
Refrigeration Grade (recommended)	99.99%
Coleman/Instrument Grade	99.99%
Research Grade	99.999%
Ultra-Pure Grade	99.9999%

CO₂ Leak Detection

Leak detectors are required anywhere that CO₂ gas may leak or be vented. Leak detectors provide an alarm if CO₂ is detected at an amount that exceeds the maximum allowable CO₂ concentration. Leak detectors are not provided with the case. Consult local safety codes for exact requirements.

Piping

All piping, whether pre-installed at the factory or added in the field, must be chosen based on the Hussmann engineering transcritical CO₂ specifications, including material type, pipe diameter, and rated maximum working pressure. The design pressure of the system is 1,305 psig (90 bar).

Approved joining methods must be used for all piping and fittings to ensure the pipe’s maximum pressure rating is maintained without reduction. The use roll-stop couplings for straight line pipe joints are recommended. Swaging of pipe joints is not recommended. Swaging weakens the copper at the swage point, reducing the maximum operating pressure rating.

- Piping—minimum design pressure greater than listed design pressure (e.g., 1,305 psig [90 bar])
- Fittings—Mueller Streamline XHP CuFe 1,885 psig (130 bar)
- Braze joints with alloy containing 15% silver (minimum)
 - Flux materials must contain no zinc and must also be water soluble
 - All field piping must be purged with nitrogen while brazing
- Schedule 40 carbon steel pipe or stainless-steel pipe
 - Must protect exterior from corrosion

Excel Open Island and Wall

Insulation

Insulation should be used in secondary system piping to reduce the heat transfer to ambient air and to maintain subcooling in the CO₂ liquid supply line to the case. The insulation should be sized to allow for the worst-case conditions of heating from store lighting and ambient temperatures. Pipe should be insulated according to local codes and customer specifications and manufacturer specifications.

When installing piping that has not been pre-insulated, there are several options for insulation. Closed-cell elastomeric insulation is extremely popular in refrigeration applications. This type of insulation can also be used in secondary system applications.

The manufacturer's internal case piping valves and components are insulated to prevent frost from building. Sufficient insulation is required on piping into the display case to eliminate frost on tubes and to minimize temperature rise of CO₂.

Check Valves and Pressure Relief Devices

Check valves are required wherever there is a possibility of trapping liquid CO₂ between valves that may be shut-off, including solenoid valves, service valves, and balancing valves. Check valves must be installed to vent high-pressure CO₂ back to the system. Hussmann recommends reverse return tubing instead of the use of shut-off valves for balancing purposes, but if shut-off valves are used, they must be relieved to the system through check valves.



Trapping of liquid CO₂ can result in extremely high pressure and must be avoided to prevent damage to equipment and personal injury.

Solenoid, check, and ball valves with integrated pressure relief must be qualified for CO₂ applications, with a minimum design pressure equal to that listed on the equipment (e.g., 1,305 psig [90 bar]).

The pressure relief device shall be mounted so that any refrigerant released from the system during its operation cannot cause harm to the user of the appliance. The aperture shall be located so that it is unlikely to be obstructed in normal use. The installed pressure relief device shall have no provisions for setting by the end user. The pressure setting of the installed pressure relief device shall be no higher than the design pressure of the high-pressure side.

Startup and Shut Down

If the refrigeration system is de-energized, venting of the R-744 (CO₂) through the pressure regulating relief valves on the refrigeration system can occur. In such cases, the system may need to be recharged with R-744 (CO₂), but in any case, the pressure regulating relief valve(s) are not to be defeated or capped. The relief setting shall not be altered.

Provisions must be made for startup and shutdown to prevent excessive pressures. Consult the pumping station instructions and local codes for requirements.

It is imperative that the case piping is clean and dry prior to charging the system with CO₂. All tubing MUST be rated with a minimum design pressure at or above the rating of the equipment. Consult equipment labeling to confirm pressure rating (e.g., 1,305 psig [90 bar]) before installation.

Excel Open Island and Wall

User Safety and Product Information

R-744 (CO₂) Pressure-Temperature Chart

A pressure-temperature chart can be found here for reference if needed: https://www.hussmann.com/ns/Supplemental_IO/GD_R-744_CO2_Pressure-Temperature_Chart_M001263_EN.pdf

Example Transcritical CO₂ System Schematic

The system illustrations content in this manual are intended as general references. Diagrams included are for typical units and may differ from the actual unit purchased. Refer to the specific drawings that come with the unit for accurate troubleshooting and maintenance. Additional drawings can be requested if needed.

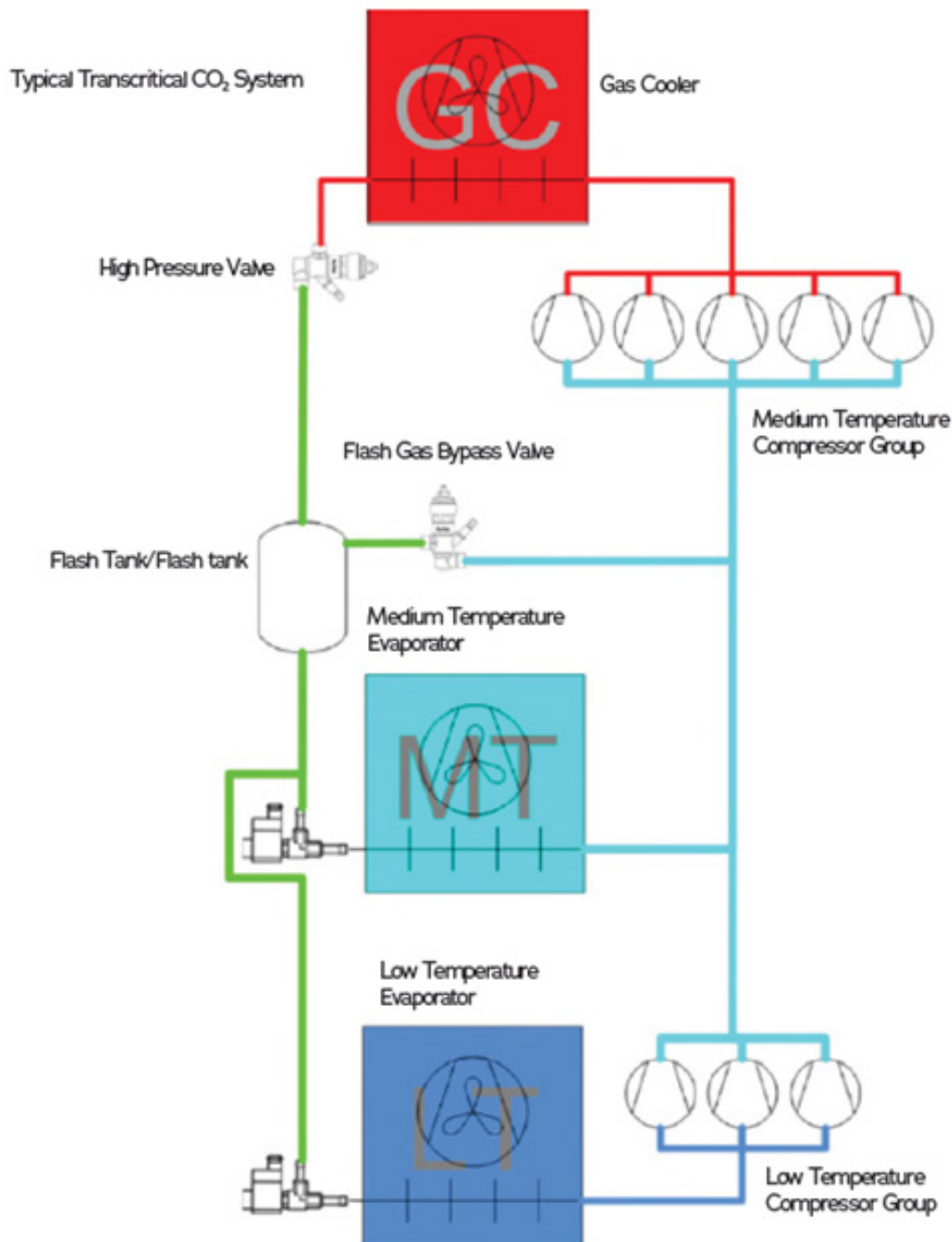

Excel Open Island and Wall

User Safety and Product Information

Example Pumped Liquid CO₂ System Schematic

Example schematic shown, actual design will vary by system.

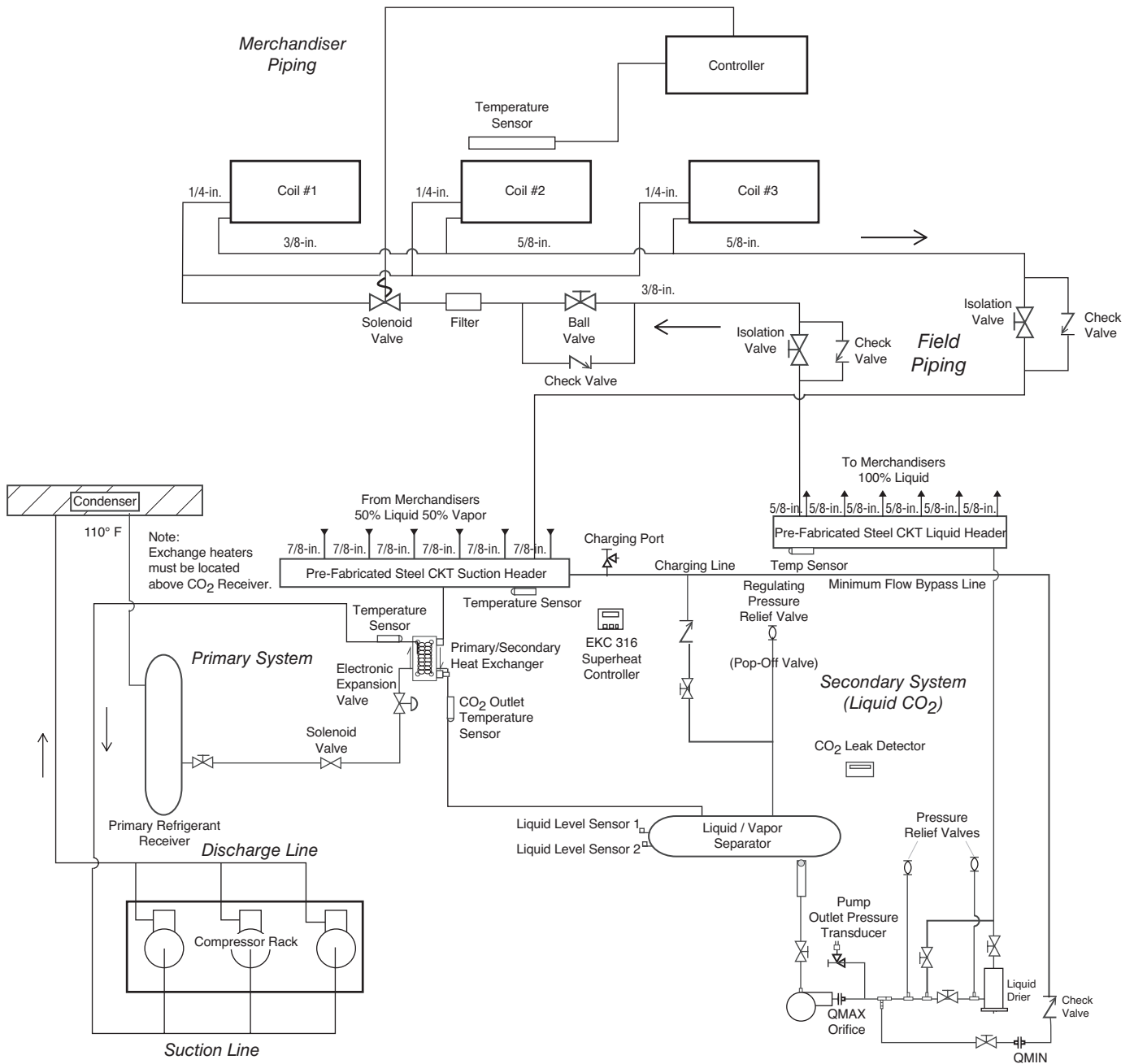

Pumped Liquid CO₂ System Schematic

Excel Open Island and Wall

User Safety and Product Information



Before Working with A2L Refrigerant



- A2L refrigerant is flammable. Equipment that is configured to use A2L refrigerants require special attention. No open flames, cigarettes, or other possible sources of ignition should be used inside or in the vicinity of equipment containing flammable refrigerants.
- Failure to follow instructions can result in an explosion, death, injury and property damage.



This refrigeration equipment was manufactured for use with A2L low-flammability refrigerants. Installation and service must only be performed by a qualified service provider.

Failure to abide by this warning could result in an explosion, death, injury, and property damage

- WARNING—Risk of fire or explosion. Flammable refrigerant used. To be repaired only by trained service personnel. Do not puncture refrigerant tubing.
- WARNING—Risk of fire. Dispose of properly in accordance with federal or local regulations. Flammable refrigerant used.
- WARNING—Risk of fire. Flammable refrigerant used. Consult repair manual/owner's guide before attempting to service this product. All safety precautions must be followed.
- WARNING—Risk of fire due to flammable refrigerant used. Follow handling instructions carefully in compliance with national regulations.
- WARNING—Risk of fire or explosion—Store in a well ventilated room without continuously operating flames or other potential ignition.
- WARNING—Risk of fire or explosion—Auxiliary devices which may be ignition sources shall not be installed in the ductwork, other than auxiliary devices listed for use with the specific appliance. See instructions.
- WARNING—In order to reduce flammability hazards the installation of this appliance must only be carried out by a suitably qualified person.
- WARNING—Risk of fire or explosion. Dispose of properly in accordance with federal or local regulations. Flammable refrigerant used.
- A2L refrigerants are denser than air.
- No open flames, cigarettes, or other possible sources of ignition should be used inside the building where the units are located until the qualified service technician and/or local fire department determines that all refrigerant has been cleared from the area and from the refrigeration systems.
- Component parts are designed for use with flammable refrigerants and are non-incendive and non-sparking. To minimize the risk of possible ignition due to incorrect parts, component parts shall only be replaced with identical repair parts. Servicing shall be done by qualified service personnel only, so as to minimize the risk of possible damage due to incorrect parts or improper service.
- Intrinsically safe components are the only types that can be worked on while live in the presence of a flammable atmosphere. The test apparatus shall be at the correct rating.

Excel Open Island and Wall

User Safety and Product Information

WARNING

- Replace components only with parts specified by the manufacturer. Other parts can result in the ignition of refrigerant in the atmosphere from a leak.
- Ducts connected to an appliance shall not contain a potential ignition source.
- Factory installed refrigerant sensors or detectors shall not be disconnected.
- Prior to beginning work on systems containing FLAMMABLE REFRIGERANTS, safety checks are necessary to ensure that the risk of ignition is minimized.
- Work shall be undertaken under a controlled procedure so as to minimize the risk of a flammable gas or vapor being present while the work is being performed.
- All maintenance staff and others working in the local area shall be instructed on the nature of work being carried out. Work in confined spaces shall be avoided.
- The area shall be checked with an appropriate refrigerant detector prior to and during work, to ensure the technician is aware of potentially toxic or flammable atmospheres. Ensure that the leak detection equipment being used is suitable for use with all applicable refrigerants, i.e., non-sparking, adequately sealed, or intrinsically safe.
- If any hot work is to be conducted on the refrigerating equipment or any associated parts, appropriate fire extinguishing equipment shall be available on hand. A dry chemical or CO₂ fire extinguisher should be adjacent to the charging area.
- No person carrying out work in relation to a REFRIGERATING SYSTEM which involves exposing any pipe work shall use any sources of ignition in such a manner that it may lead to the risk of fire or explosion. All possible ignition sources, including cigarette smoking, should be kept sufficiently far away from the site of installation, repairing, removing and disposal, during which refrigerant can possibly be released to the surrounding space. Prior to work taking place, the area around the equipment shall be surveyed to make sure that there are no flammable hazards or ignition risks. “No Smoking” signs shall be displayed.
- Ensure that the area is in the open or that it is adequately ventilated before breaking into the system or conducting any hot work. A degree of ventilation shall continue during the period that the work is carried out. The ventilation should safely disperse any released refrigerant and preferably expel it externally into the atmosphere.
- Where electrical components are being changed, they shall be fit for the purpose and to the correct specification. At all times, the manufacturer’s maintenance and service guidelines shall be followed. If in doubt, consult the manufacturer’s technical department for assistance.

The following checks shall be applied to installations using FLAMMABLE REFRIGERANTS:

- a. The actual REFRIGERANT CHARGE is in accordance with the room size within which the refrigerant containing parts are installed.
- b. The ventilation machinery and outlets are operating adequately and are not obstructed.
- c. If an indirect refrigerating circuit is being used, the secondary circuit shall be checked for the presence of refrigerant.
- d. Marking to the equipment continues to be visible and legible. Markings and signs that are illegible shall be corrected.
- e. Refrigerating pipe or components are installed in a position where they are unlikely to be exposed to any substance which may corrode refrigerant containing components, unless the components are constructed of materials which are inherently resistant to being corroded or are suitably protected against being so corroded.

Excel Open Island and Wall

User Safety and Product Information

A2L Refrigerant Detection System Overview

Refrigerant Detection System

This equipment uses a Danfoss A2L gas sensor for gas concentration monitoring as standard, factory-installed equipment. Check your individual equipment's parts list to confirm which sensor your equipment uses before ordering replacements.

Application

A2L detection devices represent distinctive and intelligent refrigerant or flammable gas detectors. They are designed to identify and precisely measure A2L refrigerants commonly employed in refrigeration applications—detecting potential flammable gas leaks. A2L stationary gas sensors are engineered to continuously monitor and identify leaks of specific flammable refrigerants.

Installer And Operator Responsibility

Sensors require installation and maintenance by a qualified technician who follows all instructions and adheres to the prevailing standards in their respective industry and location. It is crucial to note that these guidelines serve as a reference, and the manufacturer disclaims any responsibility for misuse, improper installation, or operation of these components.

Failure to install and operate the equipment in conformity with provided instructions and all industry and local guidelines may result in severe injuries, including fatality, for which the manufacturer will not be held accountable.

Maintenance

Although the A2L sensor does not require calibration throughout its operational lifespan, routine maintenance is essential to ensure its proper functioning. Routine maintenance involves checking that the sensor membrane is clean and not blocked. Blockage can be removed by lightly brushing with a clean, damp cloth.

Verify its correct operation regularly as part of a maintenance routine. Avoid cleaning the device with corrosive chemicals, solvents, or abrasive detergents. Refrain from spraying cleaning or polishing aerosols onto the device.

View the “A2L Leak Detection Sensor Service and Mitigation” section for information on components, maintenance, and service.

Sensor Life

Leak sensors have an expected fifteen-year lifespan. If any malfunction happens, and it cannot be fixed following the proper troubleshooting procedure before this period, replace it immediately to prevent any fault. This component must be replaced with the same exact part by authorized service personnel only.

It is imperative that the refrigerant sensor, which has been initially installed at the factory, remains integral and should not be intentionally disconnected. Unauthorized disconnection of the factory-installed refrigerant sensor is strictly prohibited, and maintaining its operational status is essential for ensuring the ongoing safety and functionality of the system. Any tampering or disconnection may compromise the ability to detect and alert to the presence of refrigerant, posing potential risks to both equipment and personnel. It is imperative to adhere to these guidelines to uphold the integrity of the refrigeration system and comply with safety standards.

Sensor Location and Position

The location and position of the refrigerant sensor is critical and it should not be moved. It is crucial that the sensors are located only as defined by manufacturer. The position has been determined by laboratory testing to maximize effectiveness in detecting any leak promptly. Positioning sensors as directed by the manufacturer provides accurate performance of the sensor and enhances the overall safety and reliability of the system.

The sensor has an ongoing, self-testing routine to determine if a malfunction has occurred. If the sensor detects a malfunction, the sensor will trigger a mitigation event. Additionally, when the sensor reaches end of life, it will trigger a mitigation event. In both cases, the sensor will need to be replaced to restart the system.

Excel Open Island and Wall

User Safety and Product Information

Splashguard Fans for A2L-Equipped Models

Splashguard fans are required for F-Series wall and island display cases. The fans are designed to mitigate potential flammability risks and ensure compliance with UL and ASHRAE safety standards.

A2L refrigerants are mildly flammable. A leak inside or outside the case can pose a hazard if refrigerant pools in stagnant areas. If a leak occurs, the shut-off valve system will limit the amount of refrigerant leaked, while the splashguard fan(s) mitigate flammability risk caused by the leaked refrigerant by dispersing leaked vapors away from confined spaces and toward the case's ventilation path. This ensures concentrations remain below the lower flammability limit (LFL). The splashguard fan is mounted at the bottom of the case, where refrigerant is most likely to accumulate.

As with the leak detection system, the case will not operate if the splashguard fans are not properly installed and in working order as a safety precaution. Do not attempt to operate the case without splashguard fans fully installed.

CAUTION

- Do not use hot/warm water on cold glass surfaces. This can cause the glass to shatter and could result in personal injury. Allow glass fronts to warm before applying hot/warm water.
- Do not allow cleaning agent or cloth to contact food product.
- Product will be degraded and may spoil if allowed to sit in a non-refrigerated area.

NOTICE

- Merchandiser must operate for 24 hours before loading product.
- Regularly check merchandiser temperatures.
- Do not break the cold chain. Keep products in cooler before loading into merchandiser.
- Merchandisers are designed for loading ONLY pre-chilled products.

Model Description

These case models are designed for frozen food display and are available in single-deck, wall, island, wide island, and end case configurations. Medium temperature application is available for some models. These cases are compatible for use with HFC, HFO (including A2Ls), HCFC, CO₂.

Husmann Product Control

Serial number and shipping date of all equipment is recorded in Husmann's files for warranty and replacement part purposes. All correspondence pertaining to warranty or parts ordering must include the serial number of each piece of equipment involved. This is to ensure the customer is provided with the correct parts.

Excel Open Island and Wall

Installation Information

Equipment Inspection / Shipping Damage

Upon delivery of the equipment, verify that the correct equipment has been received by comparing the information on the equipment serial label with the ordering and submittal documents. All equipment should be thoroughly examined for shipping damage before and during unloading. Equipment has been carefully inspected at our factory prior to shipment. Any claim for loss or damage must be made to the carrier. The carrier will provide any necessary inspection reports and/or claim forms.

Apparent Loss or Damage

If there is an obvious loss or damage, it must be noted on the freight bill or express receipt and signed by the carrier's agent; otherwise, carrier may refuse claim.

Concealed Loss or Damage

When loss or damage is not apparent until after equipment is uncrated, retain all packing materials and submit a written response to the carrier for inspection within 15 days.

Unloading, Moving, and Transporting Case

Move the merchandiser as close as possible to its permanent location and remove all packaging. Check for damage before discarding packaging. Remove all separately packed accessories such as kits and pan displays

Do not remove shipping braces until the merchandiser is positioned for installation.

CAUTION

Remove end braces, and discard hardware. Use caution at all times when moving merchandisers with up-tilt riders. They are top-heavy and should never be left in the vertical position. Do not stand inside or walk on case.

Shipping Rider

Each case is shipped on a rider to protect the factory installed legs, and to make positioning the merchandiser easier. DO NOT remove the rider until the case has been positioned. Once the rider is removed, the case must be lifted –NOT PUSHED– to reposition. To remove the rider, remove bolts attaching rider to each leg.

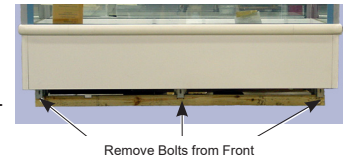

Exterior Loading

Do NOT walk on top of the merchandiser or damage to the merchandisers and serious personal injury could occur. Merchandisers are not structurally designed to support excessive external loading such as the weight of a person. Do not place heavy objects on the merchandiser.

Location

These merchandisers are designed for displaying products in air-conditioned stores where temperature is maintained at or below the ANSI / NSF-7 specified level and relative humidity is maintained at or below 55%. Refer to the label located on the merchandiser for the recommended maximum ambient operating temperature and relative humidity. Do not exceed the listed ambient conditions.

Placing refrigerated merchandisers in direct sunlight, near hot tables, or near other heat sources could impair their efficiency. Like other merchandisers, these are sensitive to air disturbances. Air currents passing around merchandisers can seriously impair their operation. Do NOT allow air conditioning, electric fans, open doors or windows, etc., to create air currents around the merchandiser.

A 4-inch (102 mm) space between the rear of the merchandiser and wall must be maintained for air circulation, except for back-to-back merchandisers. However, in high ambient conditions, sweating may still occur. If this happens, install a method of forced ventilation such as a fan ventilation kit.

Note: Under no circumstances should the top or rear of the case be in contact with elements (such as building structures, drywall, etc.) that may restrict airflow or impact operation. Consult listed clearances, or if uncertain, contact a Hussmann representative prior to installation.

Excel Open Island and Wall

Installation Information

Minimum Room Floor Area (A2L only)

The “Minimum Room Floor Area” label provides the minimum room size into which the equipment can be placed. It is the responsibility of the installer to ensure any additional piping and/or equipment is also accounted for separately during installation. Equipment shall not be placed in a room with a floor area less than the value indicated next to the symbol.

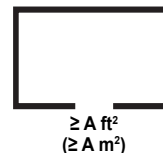

Note: Refer to the “Minimum Room Floor Area Table (piping)” to reference the appropriate piping value(s) where needed.

There are two elements related to the room area: Minimum and Actual. Based on the releasable charge determined by internal volume of every component in the equipment, a Minimum Area is calculated. The equipment cannot be used in a space with an area smaller than the Minimum Area. Depending on the Actual Area of the room, different mitigation actions are determined. The Actual Area is based on the inside dimensions of the enclosed space.

Any fluid circuits connected to the appliance (such as to a water heat exchanger) shall safely release abnormal pressure. It shall not allow the release of FLAMMABLE REFRIGERANT into areas served by the other circuits if these do not comply with minimum room area limit.

Minimum Room Floor Area Table

Model	Minimum Room Floor Area ft ² (m ²)	Estimated Refrigerant Charge ^A — lb (g)	
		Operating Charge	
		R-454A	R-454C
F8	213 (19.8)	2.4 (1,101)	2.5 (1,114)
F12	213 (19.8)	3.7 (1,695)	3.8 (1,715)
F6G	102 (9.5)	1.9 (856)	1.9 (856)
F8G	213 (19.8)	2.4 (1,108)	2.5 (1,121)
F12G	213 (19.8)	3.7 (1,695)	3.8 (1,715)
FI6, FI6G	102 (9.5)	2.2 (1,018)	2.3 (1,030)
FI8, FI8G	213 (19.8)	3 (1,353)	3 (1,353)
FI12, FI12G	213 (19.8)	4.5 (2,035)	4.5 (2,058)
FN4, FN4G	102 (9.5)	not available	not available
FN6, FN6G	102 (9.5)	1.9 (846)	1.9 (856)
FN8, FN8G	213 (19.8)	2.4 (1,108)	2.5 (1,121)
FN10G	213 (19.8)	3.1 (1,424)	3.1 (1,424)
FN12, FN12G	213 (19.8)	3.7 (1,695)	3.8 (1,715)
FW4, FW4G	102 (9.5)	not available	not available
FW6, FW6G	102 (9.5)	3.7 (1,691)	3.8 (1,711)
FW8, FW8G	213 (19.8)	4.9 (2,216)	5 (2,243)
FW12, FW12G	213 (19.8)	7.5 (3,391)	7.6 (3,430)
FWE, FWEG	102 (9.5)	1.9 (856)	1.9 (856)
FW6GH	102 (9.5)	3.7 (1,691)	3.8 (1,711)
FW8GH	213 (19.8)	4.9 (2,243)	4.9 (2,243)
FW12GH	213 (19.8)	7.5 (3,391)	7.6 (3,430)
FWEGH	102 (9.5)	1.9 (856)	1.9 (856)

^A Approximate charge based on normal operating conditions.

Excel Open Island and Wall

Installation Information

Minimum Room Floor Area Table (piping)

Liquid Line Piping Minimum Area in ft ² (m ²)										
Line Length ft (m)	Line Size (OD)									
	3/8"	1/2"	5/8"	7/8"	1 1/8"	1 3/8"	1 5/8"	1 7/8"	2 1/8"	2 5/8"
5 (1.5)	25 (2.3)	30 (2.8)	40 (3.7)	60 (5.6)	85 (7.9)	125 (11.6)	165 (15.3)	220 (20.4)	275 (25.5)	410 (38.1)
10 (3)	30 (2.8)	45 (4.2)	60 (5.6)	100 (9.3)	155 (14.4)	225 (20.9)	315 (29.2)	420 (39)	530 (49.2)	805 (74.8)
15 (4.6)	40 (3.7)	55 (5.1)	80 (7.4)	140 (13)	225 (20.9)	330 (30.7)	460 (42.7)	620 (57.6)	785 (72.9)	1,200 (111.5)
20 (6.1)	45 (4.2)	70 (6.5)	100 (9.3)	180 (16.7)	290 (26.9)	435 (40.4)	605 (56.2)	825 (76.6)	1,040 (96.6)	1,590 (147.7)
25 (7.6)	50 (4.6)	80 (7.4)	120 (11.1)	220 (20.4)	360 (33.4)	540 (50.2)	755 (70.1)	1,025 (95.2)	1,300 (120.8)	1,985 (184.4)
30 (9.1)	60 (5.6)	95 (8.8)	140 (13)	260 (24.2)	430 (39.9)	645 (59.9)	900 (83.6)	1,225 (113.8)	1,555 (144.5)	2,380 (221.1)
40 (12.2)	70 (6.5)	120 (11.1)	180 (16.7)	340 (31.6)	565 (52.5)	850 (79)	1,195 (111)	1,625 (151)	2,065 (191.8)	3,165 (294)
50 (15.2)	85 (7.9)	145 (13.5)	220 (20.4)	420 (39)	705 (65.5)	1,060 (98.5)	1,490 (138.4)	2,030 (188.6)	2,575 (239.2)	3,950 (367)
75 (22.9)	115 (10.7)	210 (19.5)	325 (30.2)	625 (58.1)	1,045 (97.1)	1,580 (146.8)	2,225 (206.7)	3,035 (282)	3,855 (358.1)	5,915 (549.5)
100 (30.5)	150 (13.9)	270 (25.1)	425 (39.5)	825 (76.6)	1,385 (128.7)	2,100 (195.1)	2,960 (275)	4,040 (375.3)	5,135 (477.1)	7,885 (732.5)
Vapor Line Piping Minimum Area in ft ² (m ²)										
Line Length ft (m)	Line Size (OD)									
	3/8"	1/2"	5/8"	7/8"	1 1/8"	1 3/8"	1 5/8"	1 7/8"	2 1/8"	2 5/8"
5 (1.5)	20 (1.9)	20 (1.9)	20 (1.9)	20 (1.9)	20 (1.9)	20 (1.9)	20 (1.9)	25 (2.3)	25 (2.3)	30 (2.8)
10 (3)	20 (1.9)	20 (1.9)	20 (1.9)	20 (1.9)	20 (1.9)	25 (2.3)	25 (2.3)	30 (2.8)	30 (2.8)	40 (3.7)
15 (4.6)	20 (1.9)	20 (1.9)	20 (1.9)	20 (1.9)	25 (2.3)	25 (2.3)	30 (2.8)	35 (3.3)	40 (3.7)	50 (4.6)
20 (6.1)	20 (1.9)	20 (1.9)	20 (1.9)	25 (2.3)	25 (2.3)	30 (2.8)	35 (3.3)	40 (3.7)	45 (4.2)	60 (5.6)
25 (7.6)	20 (1.9)	20 (1.9)	20 (1.9)	25 (2.3)	30 (2.8)	30 (2.8)	40 (3.7)	45 (4.2)	50 (4.6)	70 (6.5)
30 (9.1)	20 (1.9)	20 (1.9)	20 (1.9)	25 (2.3)	30 (2.8)	35 (3.3)	40 (3.7)	50 (4.6)	60 (5.6)	80 (7.4)
40 (12.2)	20 (1.9)	20 (1.9)	25 (2.3)	25 (2.3)	35 (3.3)	40 (3.7)	50 (4.6)	60 (5.6)	70 (6.5)	100 (9.3)
50 (15.2)	20 (1.9)	20 (1.9)	25 (2.3)	30 (2.8)	35 (3.3)	45 (4.2)	55 (5.1)	70 (6.5)	85 (7.9)	120 (11.1)
75 (22.9)	20 (1.9)	25 (2.3)	25 (2.3)	35 (3.3)	45 (4.2)	60 (5.6)	75 (7)	95 (8.8)	120 (11.1)	170 (16)
100 (30.5)	20 (1.9)	25 (2.3)	30 (2.8)	40 (3.7)	55 (5.1)	75 (7)	95 (8.8)	125 (11.6)	150 (13.9)	225 (20.9)

Excel Open Island and Wall

Installation Information

Leveling Case

Before installation, ensure merchandisers are properly positioned and level at all four corners. A level installation is critical for optimal refrigeration performance and proper defrost water drainage. The merchandiser must be level both front-to-back and side-to-side to ensure effective condensate drainage and correct door alignment and operation. Select a level area for installation.

Preparation

1. Review store blueprints and mark merchandiser footprint on the floor.
2. Maintain 3-inch clearance behind and at each end of merchandiser(s) to prevent condensation.
3. Snap chalk lines for front and rear base leg positions.
4. Mark joint locations along chalk lines.

Finding the Highest Point

1. Walk the floor to identify dips or mounds.
2. Use a string level, laser level, or transit to find

Leveling Island or End Merchandisers

1. Position first merchandiser at highest point.
2. Use a 4 ft (1220 mm) level on discharge air flue for end-to-end leveling.
3. Use a 24 in (610 mm) level on end frame flange for front-to-rear leveling.
4. Insert shims as needed: 6 legs for 8 ft (2438 mm) merchandisers, 8 legs for 12 ft (3658 mm) merchandisers
5. Ensure all merchandisers in lineup are leveled to the same plane.

Leveling Wall Merchandisers

1. Start at rear corners; place shims under rear base rail ends.
2. Level rear end-to-end.
3. Move to front corners; shim as needed for front-to-rear and end-to-end leveling.
4. Support merchandiser every 4 ft (1220 mm).
5. Insert shims under center front and rear legs if gaps are present

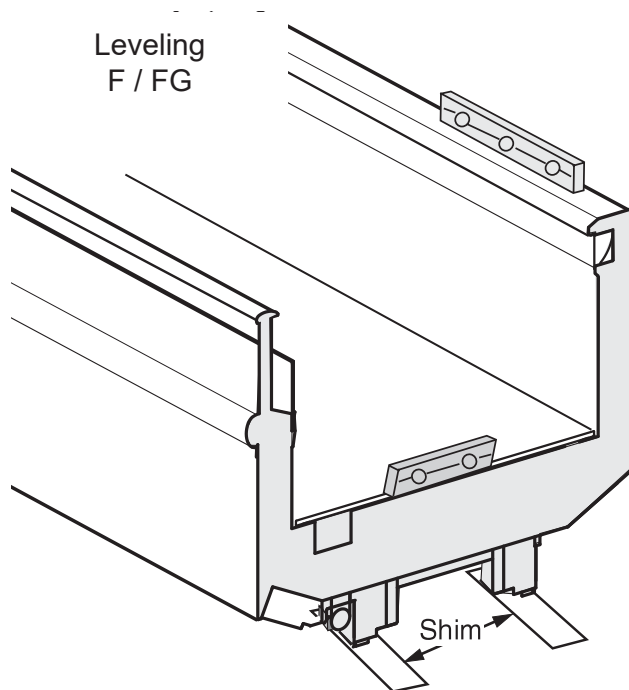

Note: Do not place levels on Display Pans or on Racks.

Excel Open Island and Wall Installation Information

Case Joining

Joining kits and instructions are shipped with each merchandiser as ordered. To join like fixtures, a joining kit is required. Sectional construction means that two or more merchandisers may be joined in line yielding one long, continuous display requiring only one pair of ends.

- All joints must be air-tight to prevent formation of ice or condensation.

Preparation

1. Check to be sure that merchandisers are level. Locate joining kit and check contents.
2. Remove wire racks and display pans before removing interior front and back panels.
3. Verify upper front panel, front panel, bumper retainer, and top rail alignment before joining merchandisers, and shim as necessary. Panels and top rail must have equal overhang at each end of merchandiser.

Note:

Merchandisers must be leveled before joining. Verify all top rails, panels and bumper retainers of each merchandiser to be joined align vertically before joining.

To correct vertical alignment of top rails and upper front panel, adjust shims as necessary.

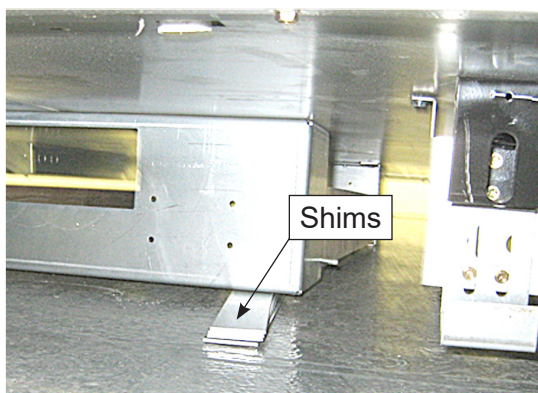
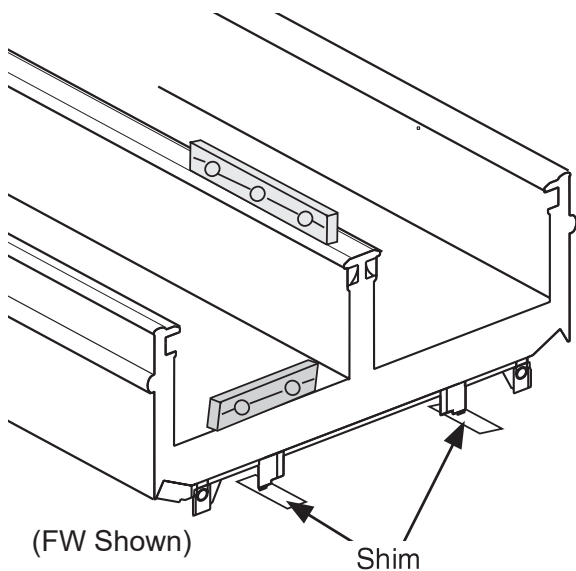

Excel Open Island and Wall

Installation Information

Joining instructions for case models:
 RL / RM / RMF
 RLN / RMN and RLNI

Remove the fasteners holding the retainers for the discharge air louvers. (Lift louvers up and out from the bottom.) Remove any return air flue plex-glass parts. (Lift up on interior panels to remove.)

Note:

FWE and FWEГ end merchandisers have joining fasteners inserted in the appropriate locations. Remove nuts and washers from outside of end merchandiser before attempting to join.

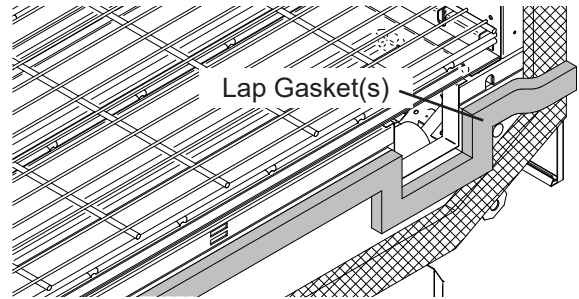

Apply Gaskets to Right End

1. Apply the 1⁵/₈ in. (41 mm) gasket around the perimeter of the merchandiser as shown. It must be at the edge. Check to be sure that there are no gaps between gasket and merchandiser.
2. Apply the 1 in. (25 mm) gasket across the end shoe as shown. Each end of the gasket should extend onto the 1⁵/₈ inch gasket but not over. Check to be sure that there are no gaps between merchandiser and gaskets.
3. On narrow and intermediate islands, wall merchandisers, and cases, apply the 1 in. (25 mm) gasket at the top of the discharge and return air flues as shown. On wide islands, apply the 1 in. (25 mm) gasket at the top of return air flues as shown. Apply the 1⁵/₈ in. (41 mm) gasket at the top of the discharge (center) flue as shown.

Note:

When adding an end merchandiser, apply gaskets to the wide island, not the end merchandiser.

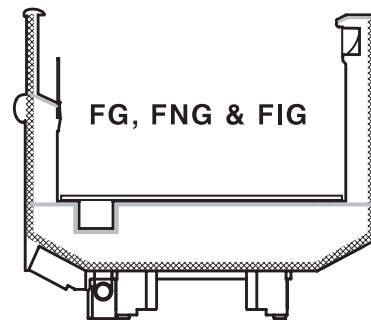

▨ 1 5/8 x 1/2 Foam Gasket
 — 1 x 1/2 Foam Gasket

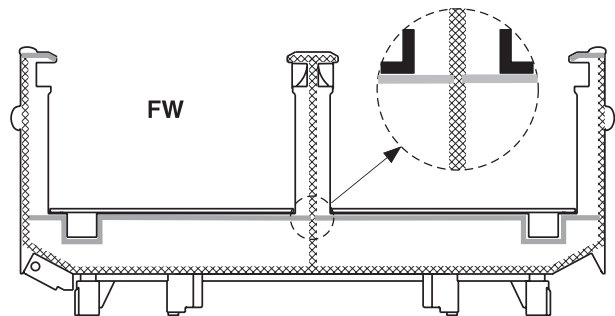

▨ 1 5/8 x 1/2 Foam Gasket
 — 1 x 1/2 Foam Gasket

IMPORTANT

- Do not stretch gasket, especially around corners.
- Do not butt gaskets; always overlap them as shown.
- Remove paper backing after gasket has been applied.
- Perimeter gasket is required by NSF.

Excel Open Island and Wall Installation Information

Joining instructions for case models:
RL / RM / RMF
RLN / RMN and RLNI

Joining End Merchandiser to Wide Islands

Note:

Merchandisers must be level before joining.

1. Remove nuts and washers from outside of end case.
2. Apply gaskets to wide island.
3. Move end as close to the wide island as possible by using lever bar (mule). Take care not to damage optional adjustable legs.



4. Verify upper front panel, front panel, bumper retainer, and top rail alignment before joining cases, and shim cases as necessary.

Note:

Merchandiser must be leveled before joining. Verify all top rails, panels and bumper retainers of each merchandiser to be joined align vertically before joining.

To correct vertical alignment of top rails and upper front panel, adjust optional legs and, or shims as necessary.

Note that alignment order is different from tightening order!

Verify alignment of panels, bumper retainer and top rail.



Adjust (optional) legs or shim cases to ensure vertical alignment of panels and top rails.

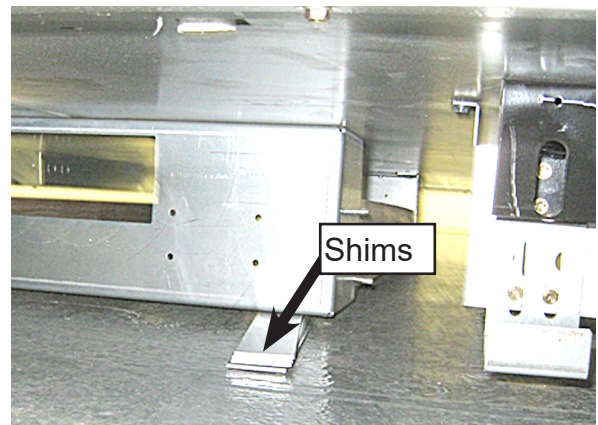

Install fasteners (parent to end).

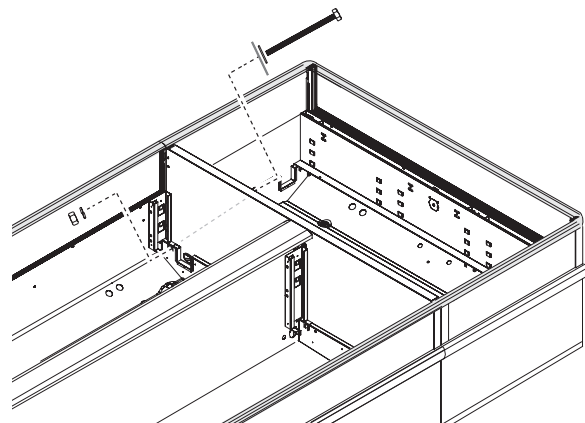

Excel Open Island and Wall Installation Information

5. Align end case with wide island frame. Fastener size and location are detailed on the following pages. Loosely assemble bolt, washers, lockwasher and nuts as shown here.

Joining hardware is shown enlarged for clarity.

Note that alignment order is different from tightening order! Do not attempt to draw merchandisers together using nut and bolt.

Note:

H-Shaped Joining Clip is not used when joining end merchandisers with stainless steel rails.

Bumper retainers allow for slight lateral movement for both solid and glass front merchandisers.

6. Join bumper retainers.

Joining brackets are installed in factory. Be sure to loosen joining bracket screws before tightening and joining the bumper brackets.

Tighten the screws of joining brackets after tightening the other screws according to Sequence shown on the following pages.

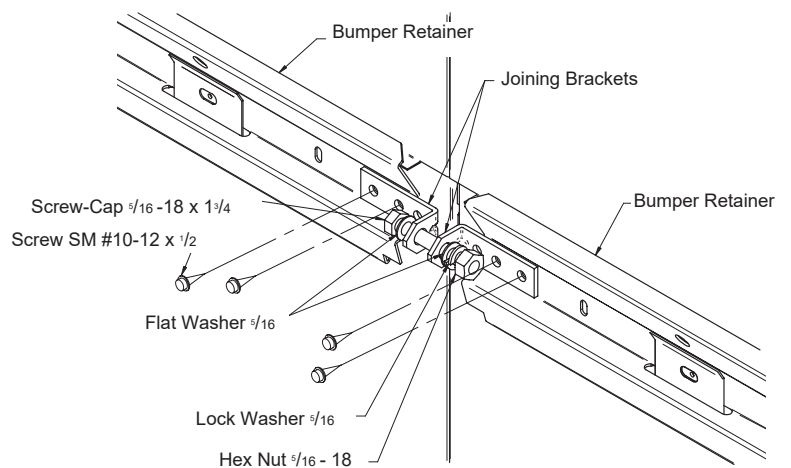
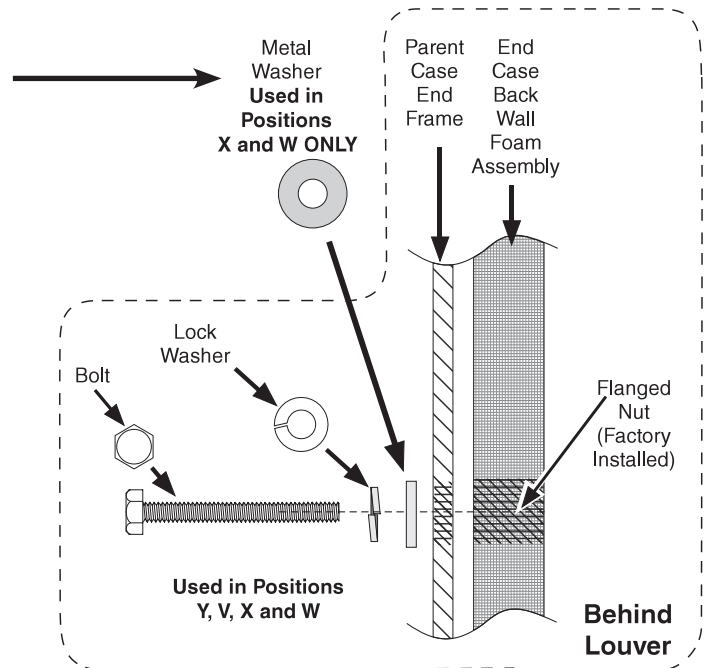

Excel Open Island and Wall Installation Information

Parent to Parent Installation KEY:

- T — Center Flue End Cap Alignment Pin
- U — 5/16-18 X 1 3/4 in. Hex Head Screw
- V — 5/16-18 X 3 1/2 in. Hex Head Screw
- W — 5/16-18 X 1 3/4 in. Hex Head Screw
- X — (Used for End Case Only)
- Y — M6 - 1.0 X 25 mm Hex Head Screw
- Z — Joining Clip

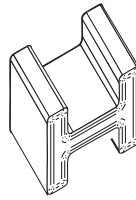

Joining Clip

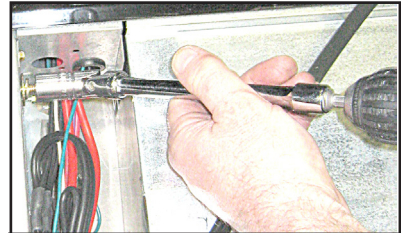

Use a socket with a U-joint adjustable adapter to more easily tighten fasteners.

FW to FW

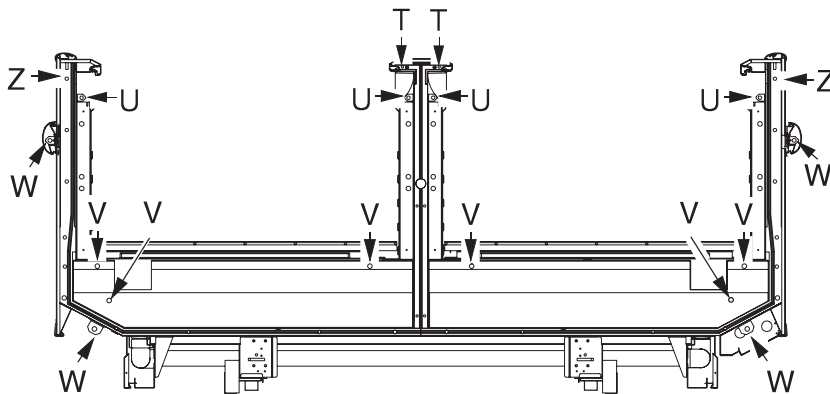

FWG to FWG

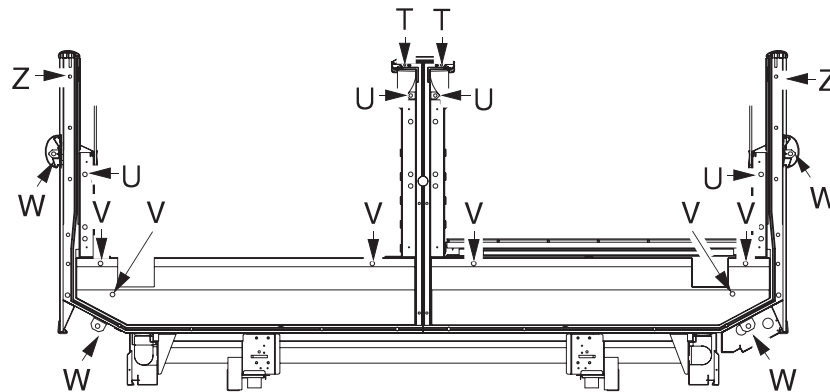

FWGH to FWGH

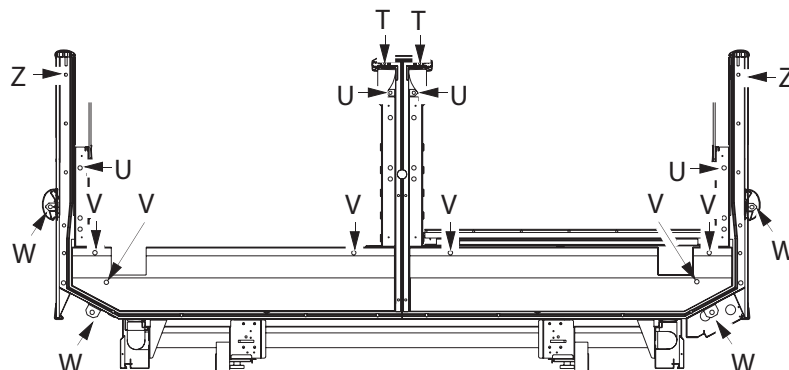

Excel Open Island and Wall

Installation Information

Parent to End Installation KEY:

- T — Center Flue End Cap Alignment Pin
- U — 5/16-18 X 1 3/4 in. Hex Head Screw
- V — 5/16-18 X 3 1/2 in. Hex Head Screw
- W — 5/16-18 X 1 3/4 in. Hex Head Screw
- X — 5/16-18 X 4 1/2 in. Tap Bolt
- Y — M6 - 1.0 X 25 mm Hex Head Screw
- Z — Joining Clip

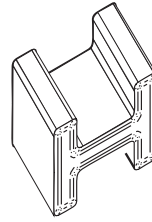

Joining Clip

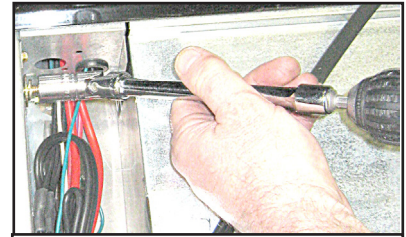

Use a socket with a U-joint adjustable adapter to more easily tighten fasteners.

FW to FWE

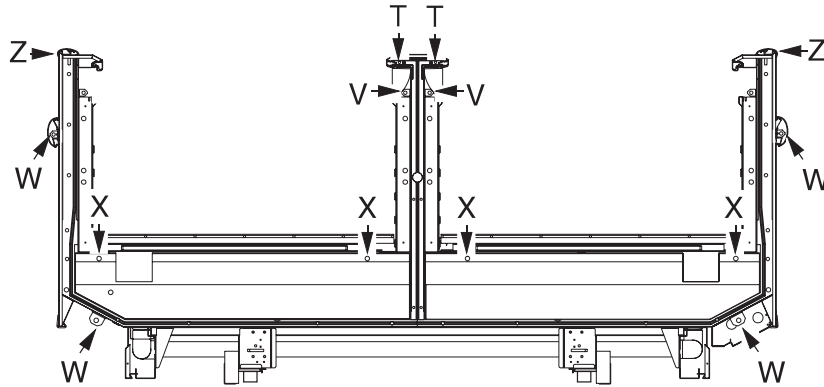

FWG to FWE

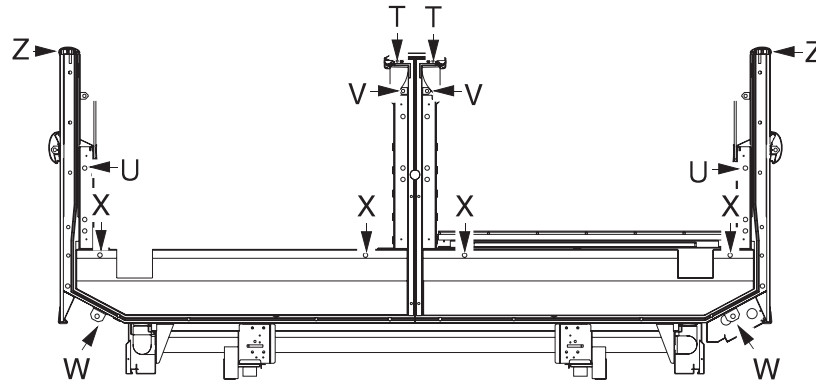

FWGH to FWE

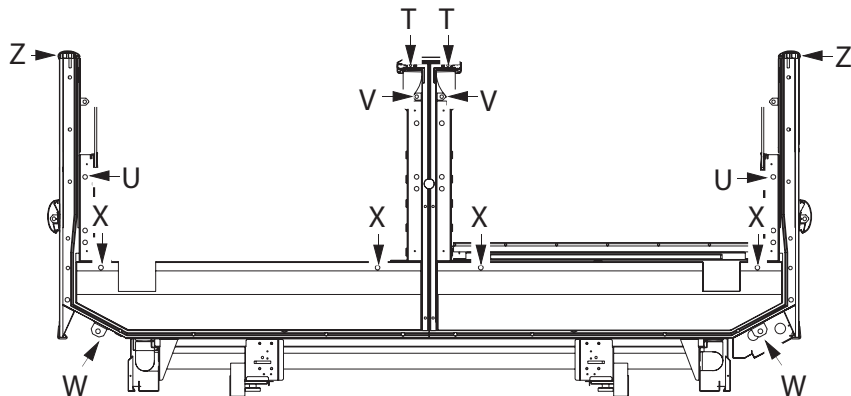

Excel Open Island and Wall

Installation Information

Fasten End Frames

1. Tighten joints in the order shown until gaskets are compressed, and merchandisers join smoothly. Work from the lower front to lower back to upper back. Fasten the upper front last.

When joining End merchandisers to Wide Islands, follow the joining order for the wide island, beginning with 1A and 1B.

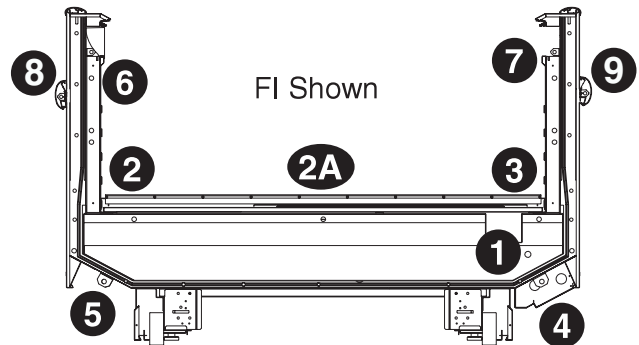

Tighten in Order Shown

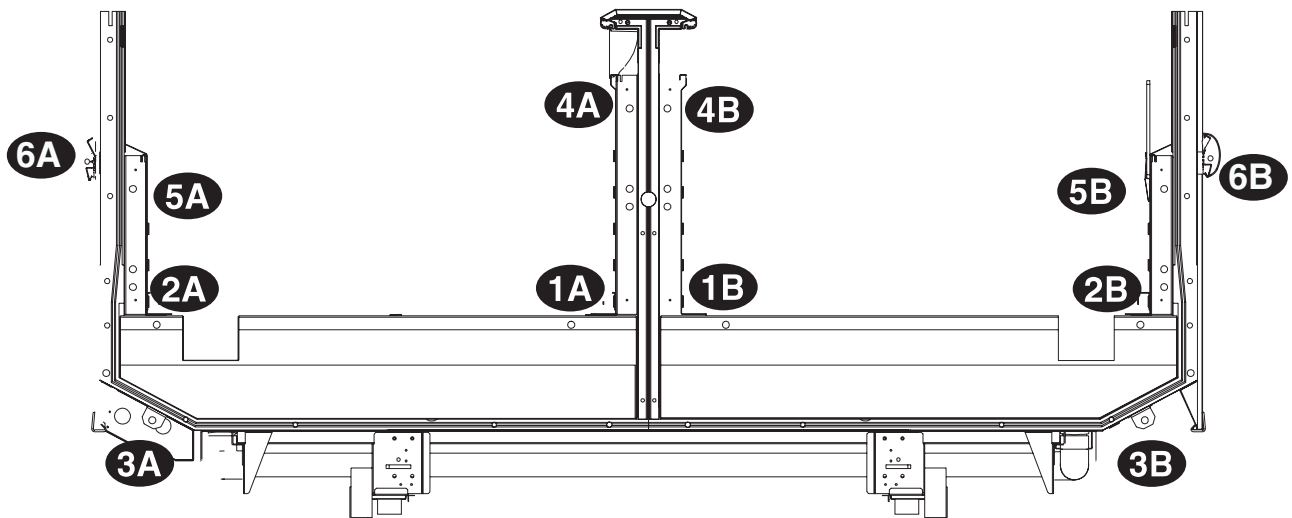

Tighten in Order Shown

Excel Open Island and Wall Installation Information

Sealing Merchandisers

1. Remove wire rack, rack supports and interior panels to apply butyl tape.

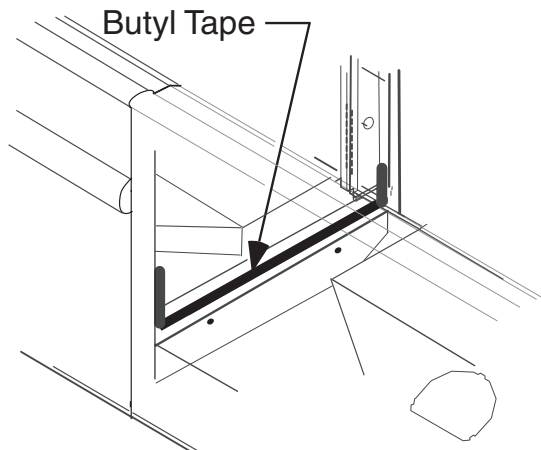

2. Apply butyl tape across the bottom joint. Be sure to extend the tape up the back and front of the merchandiser.

Silicone sealer may be applied around joining bolts on both sides in bottom shoe.

Installing Splashguard Brackets

Position splashguard brackets to the merchandiser and level to the floor. Each bracket has a 1 1/2 in. (38 mm) slot at the rear of the bracket where it attaches to the merchandiser. Tighten screws to secure the brackets.

Important:

Install splashguard brackets before installing drip piping.

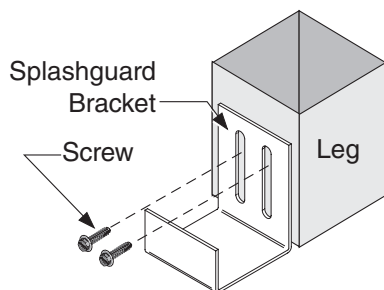

Replacing Interior Panels and Discharge Air Louvers

After case joining is complete and all joining bolts are fastened, re-install the interior front and back panels. Special care needs to be taken when re-installing the discharge air louvers. The flange at the top of the louver must properly fit into the correct position in the extrusion. Incorrect position of the louver can cause the plastic nosing on the anti-sweat heater to become dislodged. See details in Section 6 for correct steps to re-install plastic nosing extrusion.

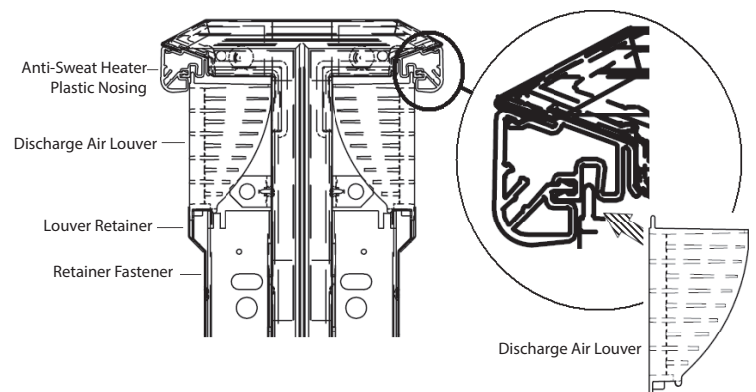

Excel Open Island and Wall Installation Information

Installing Flue Glass

FNG & FIG

The louvers, flue glass, retainer and brackets are shipped loose and must be installed before the lineup can be started up.

1. Apply flue glass Retainer to the top of each section of flue glass.
2. Position the glass in the merchandiser.
3. Slide a Discharge Deflector Bracket into each bend of the and into the flue glass retainer.

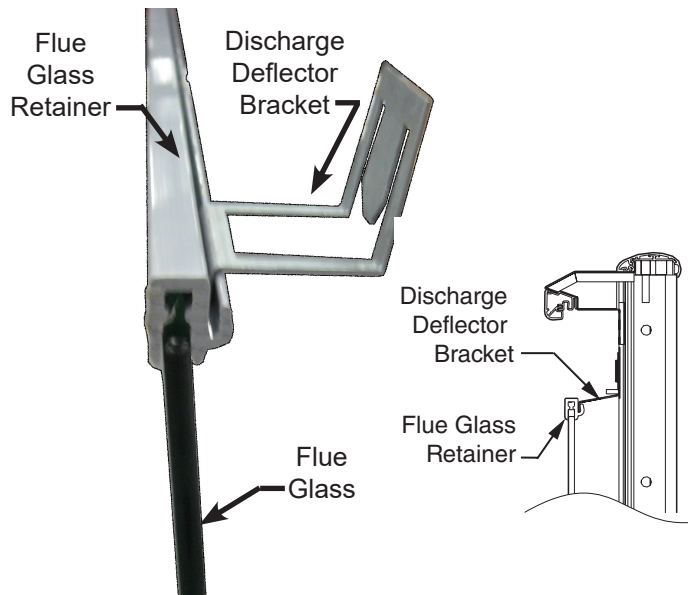

Installing Flue Glass Clamp (FWGH & FWEHG)

The flue glass retainer is installed as shown below. Insert supplied bolts (4) through retainer, Bolts fasten into factory-installed nut retainers.

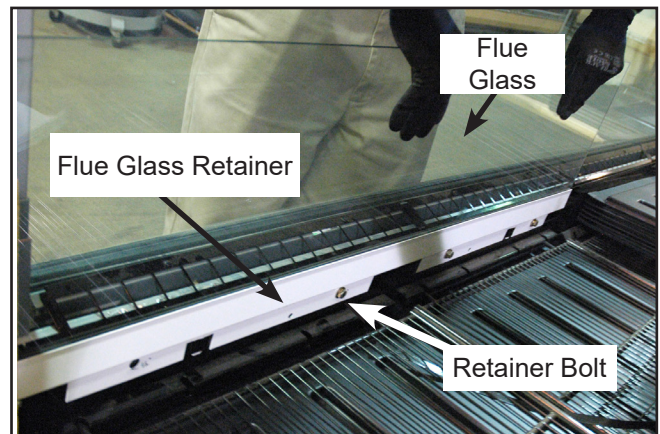
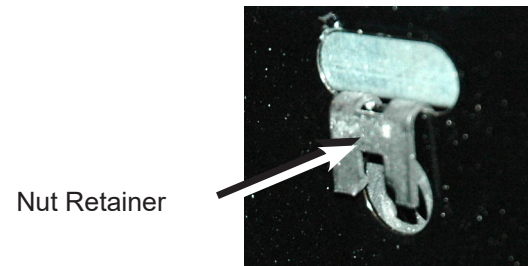

The flue glass is packed inside of the case. Remove the packaging, and slide flue glass securely into top lip of flue glass retainer. Fasten (4) bolts into nut retainers.

DO NOT over-tighten bolts.

Installing Partitions

To join same temperature fixtures on different defrost cycles, an acrylic partition kit is required.

To join unlike fixtures, or like fixtures operating at different temperatures, an insulated partition kit is required. It must be installed when setting the lineup. Instructions for installing these partitions are included with the kits.

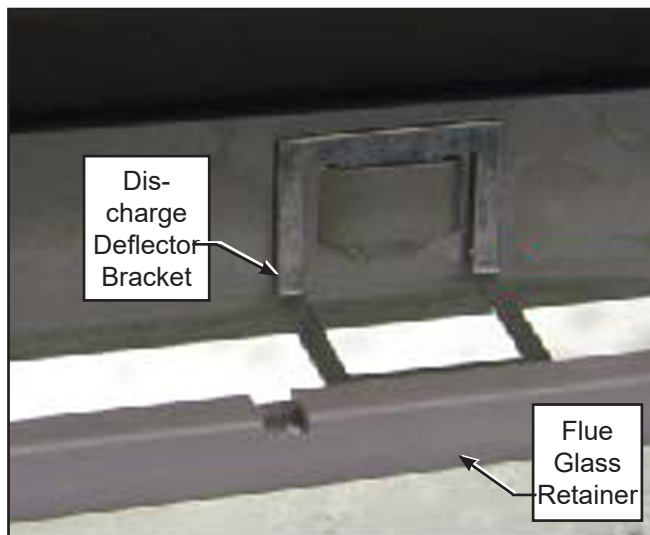

Excel Open Island and Wall Installation Information

Installing End Assemblies

End assemblies are normally factory installed. The following information is provided for retrofit or field installation.

1. Prepare Merchandiser
 - a. Remove display racks, pans, front rack supports and front air grilles from section of case where end is to be installed.
 - b. Remove the interior back panel. No tools required.
2. Apply gaskets to end frame
3. Fasten End Assembly to Merchandiser
 - a. Use Bolt and washer to fasten end assembly to merchandiser in the same way the end merchandiser is fastened.
 - b. Tighten in order shown for joining.
4. Seal End to End Frame
 - a. Remove front shelf and shelf support bracket. Apply a ½ in. bead of silicone at the back of the case, starting at the first slot. Continue across the bottom and up the front as shown below. Use field-supplied silicone in any gap between front support bracket and end assembly.
 - b. Re-install bumpers as described beginning on Page 1-16.
5. Install End Splashguard Bracket. Insert back of bracket through slot in leg. Use Screws to attach End Splashguard Retainer to end frame.

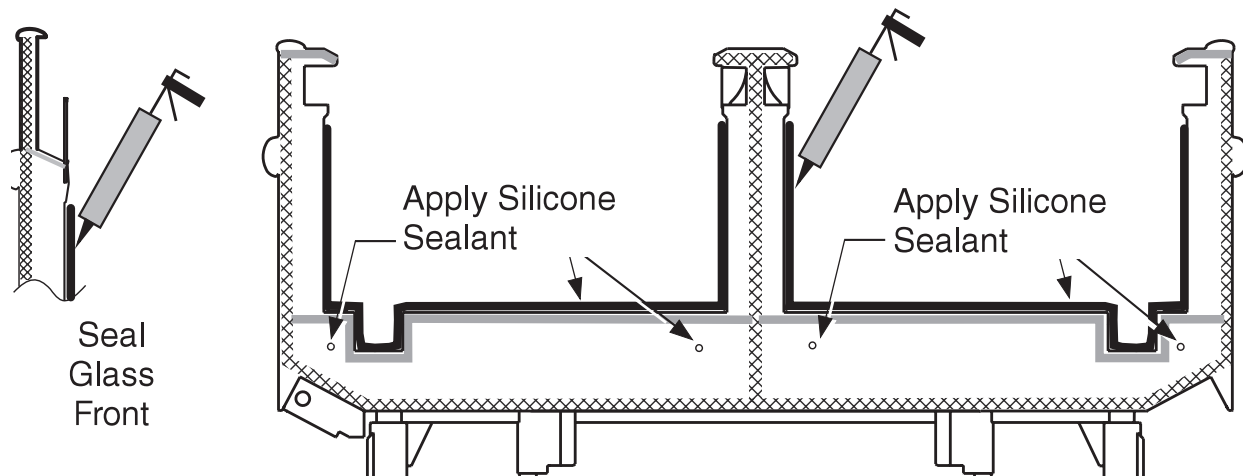
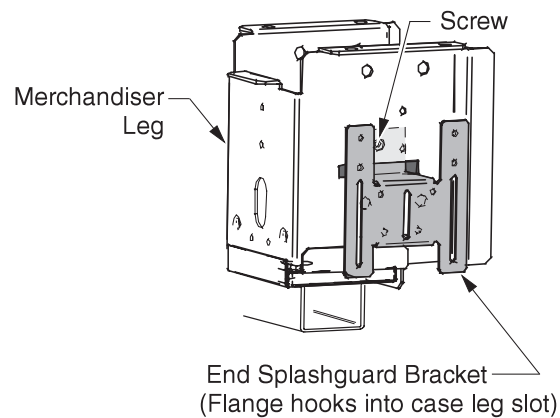

Excel Open Island and Wall

Installation Information

Piping Overview

Important: Since Hussmann has no direct control over the installation, providing freeze-burst protection is the responsibility of the installing contractor.

System design must conform to all local and national codes, laws, and regulations applying to the site of installation. In addition, the safety code for mechanical refrigeration (ASME B31.5) should be followed as a guide for installation and operation practice.

Refrigerant line sizes and piping techniques should be obtained from the ASHRAE guide or equivalent reference. Under no circumstances should the refrigerant connection size of the equipment be used as the basis for sizing the lines.

The horizontal suction line should slope away from the equipment toward the compressor. Vertical suction risers may require a trap at the bottom of the riser for proper oil return.

CO₂ Piping

Piping Materials

Any piping material that meets all pressure and temperature ratings, material compatibility requirements and state and local building codes may be used for pumped liquid CO₂ applications. The design pressure of the system is labeled on the unit. Any connected components must meet the system design pressure (e.g., 1,305 psig [90 bar]).

Approved joining methods must be used for all piping and fittings to ensure the pipe's maximum pressure rating is maintained without reduction. The use roll-stop couplings for straight line pipe joints are recommended. Swaging of pipe joints is not recommended. Swaging weakens the copper at the swage point, reducing the maximum operating pressure rating.

CO₂ Piping Material

- Piping—minimum design pressure greater than system design pressure (e.g., 1,305 psig [90 bar])
- Fittings—Mueller Streamline XHP CuFe 1,885 psig (130 bar)
- Braze joints with alloy containing 15% silver (minimum)
 - Flux materials must contain no zinc and must also be water soluble
 - All field piping must be purged with nitrogen while brazing
- Schedule 40 carbon steel pipe or stainless-steel pipe
 - Must protect exterior from corrosion

Insulation

Insulation should be used in secondary system piping to reduce the heat transfer to ambient air and to maintain subcooling in the CO₂ liquid supply line to the case. The insulation should be sized to allow for the worst-case conditions of heating from store lighting and ambient temperatures. Pipe should be insulated according to local codes and customer specifications and manufacturer specifications.

When installing piping that has not been pre-insulated, there are several options for insulation. Closed-cell elastomeric insulation is extremely popular in refrigeration applications. This type of insulation can also be used in secondary system applications.

The manufacturer's internal case piping valves and components are insulated to prevent frost from building. Sufficient insulation is required on piping into the display case to eliminate frost on tubes and to minimize temperature rise of CO₂.

Excel Open Island and Wall

Installation Information

Check Valves

Check valves are required wherever there is a possibility of trapping liquid CO₂ between valves that may be shut off, including solenoid valves, service valves, and balancing valves. Check valves must be installed to vent high pressure CO₂ back to the system. Hussmann recommends reverse return tubing instead of the use of shutoff valves for balancing purposes, but if shutoff valves are used, they must be relieved to the system through check valves.

WARNING—Trapping of liquid CO₂ can result in extremely high pressure and must be avoided to prevent damage to equipment and personal injury.

Solenoid, check, ball valves, and ball valves with integrated pressure relief must be qualified for CO₂ applications, with a minimum design pressure equal to or greater than the equipment design pressure (e.g., 1,305 psig [90 bar]).

Pumped Liquid R-744 (CO₂) Supply Piping

For systems utilizing pumped liquid CO₂, the liquid supply lines should be sized using the same guidelines as liquid lines. However, it is crucial to recognize that CO₂-pumped liquid is more resistant to pressure drop than standard liquid lines. The CO₂ pump introduces mechanical subcooling, enabling a higher pressure drop before the liquid begins to vaporize.

To ensure optimal performance, a system analysis is necessary to determine the maximum permissible pressure drop in both the supply and return lines. The combined pressure drop in the recirculation lines, the pressure drop across all system components, and any pressure changes due to elevation differences should not exceed the specified pressure differential rating of the pump.

Pumped Liquid R-744 (CO₂) Return Piping

For systems utilizing pumped liquid CO₂, the liquid return lines will carry a mixture of both liquid and vapor, with the exact ratio determined by the liquid overfeed rate. A system analysis must be conducted to identify the maximum permissible pressure drop in both the supply and return lines. The total pressure drop across the recirculation lines, all system components, and any changes in pressure due to elevation must not exceed the rated pressure differential of the pump.

It is essential to avoid over-sizing the liquid return riser lines. If the velocity becomes too low, liquid and vapor phases may separate, causing a significant increase in pressure drop as liquid accumulates in the vertical riser.

In pumped liquid CO₂ systems, the liquid temperature typically falls below 30° F (-1.1° C). Therefore, it is essential to adequately insulate these lines to prevent condensation and minimize heat absorption. Failure to properly insulate liquid lines can reduce the cooling capacity, leading to suboptimal system performance.

Application data for display cases can be found at Hussmann.com

Excel Open Island and Wall

Installation Information

Additional Piping Installation Requirements

- Installation shall include protection from physical damage in operation and service and be in compliance with national and local codes and standards, such as ANSI/ASHRAE 15, IAPMO Uniform Mechanical Code, ICC International Mechanical Code, or CSA B52. All field joints shall be accessible for inspection prior to being covered or enclosed.
- The installation of pipework shall be kept to a minimum.
- A brazed, welded, or mechanical connection shall be made before opening the valves to permit refrigerant to flow between the refrigerating system parts.
- Mechanical connectors used indoors shall comply with ISO 14903 or UL 207 or CSA C22.2 No. 140.3. When mechanical connectors are reused indoors, sealing parts shall be renewed. When flared joints are reused indoors, the flare part shall be refabricated.
- Refrigerant tubing shall be protected or enclosed to avoid damage. Flexible refrigerant connectors (such as connecting lines between an indoor and outdoor unit) that might be displaced during normal operation shall be protected against mechanical damage.
- Mechanical connections shall be accessible for maintenance purposes.
- Provision shall be made for expansion and contraction of long runs of piping.
- Protection devices, piping, and fittings shall be protected as far as possible against adverse environmental effects, for example, the danger of water collecting and freezing in relief pipes or the accumulation of dirt and debris.
- Piping in refrigeration systems shall be so designed and installed to minimize the likelihood of hydraulic shock damaging the system.
- Steel pipes and components shall be protected against corrosion with a rustproof coating before applying any insulation.
- Flexible pipe elements shall be protected against mechanical damage, excessive stress by torsion, or other forces, and they should be checked for mechanical damage annually.
- Precautions shall be taken to avoid excessive vibration or pulsation of the refrigerant piping.
- Look for the room area label on the equipment to identify the minimum room size. The information in this manual can also be used as an estimate. Always confirm the exact value on the equipment before installation.
- After completion of field piping for split systems, the field pipework shall be pressure tested with an inert gas and then vacuum tested prior to refrigerant charging, according to the following requirements as detailed by UL safety standard. Pressures may come from equipment data label or from customer specification.
 1. The minimum test pressure for the low side of the system shall be the low side design pressure and the minimum test pressure for the high side of the system shall be the high side design pressure, unless the high side of the system cannot be isolated from the low side of the system in which case the entire system shall be pressure tested to the low side design pressure.
 2. The test pressure after removal of the pressure source shall be maintained for at least 1 hour with no decrease of pressure indicated by the test gauge, with rest gauge resolution not exceeding 5% of the test pressure.
 3. During the evacuation test, after achieving a vacuum level specified in the manual or less, the refrigeration system shall be isolated from the vacuum pump and the pressure shall not rise above 1500 microns within 10 min.

Excel Open Island and Wall

Installation Information

- Field-made refrigerant joints indoors shall be tightness tested according to applicable codes and requirements. The test method shall have a sensitivity of 0.18 oz (5 g) per year of refrigerant or better under a pressure of at least 0.25 times the maximum allowable pressure. No leak shall be detected.
- Equipment piping in the occupied space shall be installed in such a way to protect against accidental damage in operation and service.
- Any solenoid valves shall be correctly positioned in the piping to avoid hydraulic shock or pressure.
- Insulation shall be suitable for use with the material being insulated.
- The indoor equipment and pipes shall be securely mounted and guarded such that accidental rupture of equipment cannot occur from such events as moving furniture or reconstruction activities.

Line Connection Sizes

Consult the unit datasheet or contact a Hussmann representative for unit-specific line size inquiries.

Waste Outlet/Drain Line

All information about waste/drain setup required to install and ensure proper function.

Refrigerant Piping

Standard Connection Location

When brazing pipes, always use the insulation blanket shipped with the merchandiser to protect the plastic case bottom from heat damage. The refrigerant line connections are located at the right-hand end of the merchandiser—this is the end opposite the main serial label, beneath the display pans. A sticker marks the exact location of the connection point.

To exit the cases, the installer must saw a hole. Each case ships with a refrigeration shroud, which must be positioned correctly before making any connections. Place the shroud over the refrigeration piping so that when it is rotated into place, it will be in the upright position. Refer to Figure 2-1 for proper orientation.

Take care not to burn, scorch, or overheat the shroud during brazing. After completing the connections, apply silicone sealant to the bottom of the shroud as shown in Figure 2-2. Then, rotate and center the shroud over the refrigeration outlet foam pad, as illustrated in Figure 2-3.

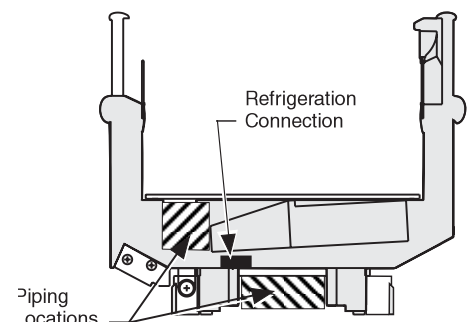
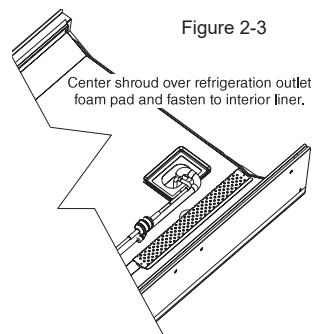
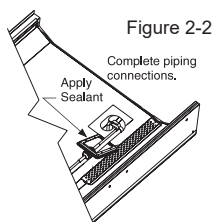
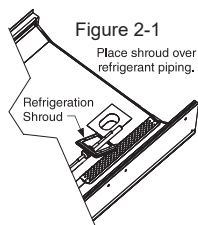

Excel Open Island and Wall Installation Information

A2L Piping Connection Locations

A2L cases are piped to the outside of the case. For taller models (4-, 5-, and 6-deck), the piping connections are located on the top-right side of the case.

FWG model shown from underneath the case. Other F-Series models have similar A2L piping locations.

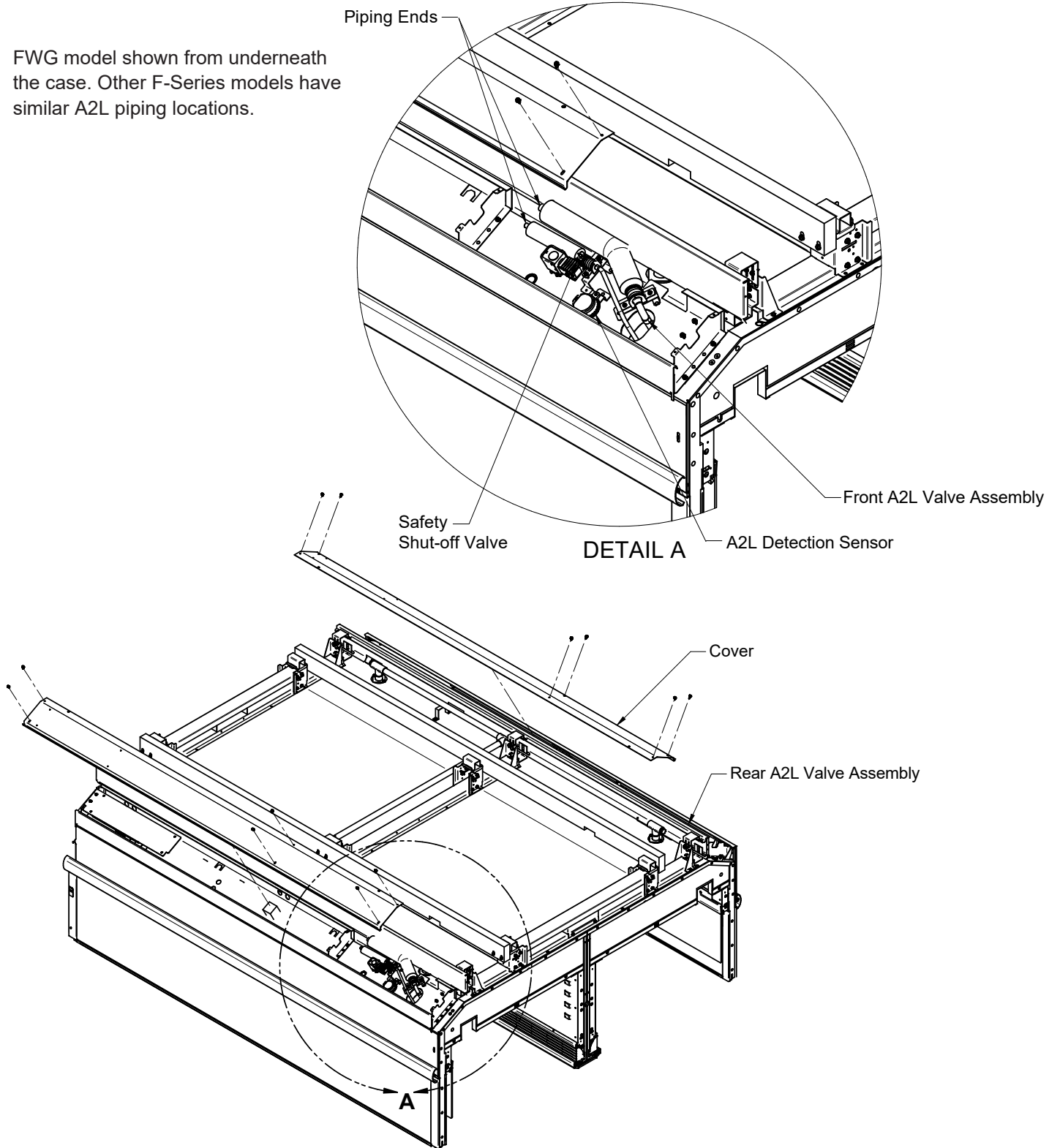

Excel Open Island and Wall

Installation Information

Multiplexing

Piping of merchandisers operating on the same refrigeration system may be run from merchandiser to merchandiser through the end frame saddles provided for this purpose. Do NOT run refrigerant lines through merchandisers that are NOT on the same refrigeration system as this may result in poor refrigeration control and compressor failure.

Note: If Gas defrost is used, the liquid line will need to be increased two sizes larger inside the merchandiser area. This is necessary to ensure even liquid drainage from all evaporators during defrost.

Line Sizing

- Refrigerant lines should be sized as shown on the refrigeration legend that is furnished for the store or according to ASHRAE guidelines.

Oil Traps

- P-traps (oil traps) must be installed at the base of all suction line vertical risers.

Pressure Drop

- Pressure drop can rob the system of capacity. To keep the pressure drop to a minimum, keep the refrigerant line run as short as possible using a minimum number of elbows. Where elbows are required, use long radius elbows only.

Insulation

With GAS Defrost:

The suction and liquid lines should not contact each other and should be insulated separately for a minimum of 30 ft (9.1 m) from the merchandiser.

With Other Than Gas Defrost:

The suction and liquid lines should be clamped or taped together and insulated for a minimum of 30 ft (9.1 m) from the merchandiser.

With All Defrost:

Additional insulation for the balance of the liquid and suction lines is recommended wherever condensation drippage is objectionable or the lines are exposed to ambient conditions.

Excel Open Island and Wall

Installation Information

Branch Line Piping

The following information is applicable only for piping Hussmann merchandisers to Hussmann refrigeration equipment.

Suction Line – All Defrosts

- Pitch in direction of flow.
- May be reduced by one size at one third of case run load and again after the second third. Do NOT reduce below evaporator connection size.
- Suction returns from evaporators enter at the top of the branch line.

Liquid Line – Off-time and Electric Defrost

- May be reduced by one size after one half the case load run. Do not reduce below evaporator connection size.
- Take-offs to evaporators exit the bottom of the liquid line. Provide an expansion loop for each evaporator take-off (minimum 3 in. [76 mm] diameter).

Liquid Line – Koolgas Defrost

Maximum of 6 evaporators per Branch System.

Increase the liquid line size inside the case by two sizes over the branch size.

Branch Size	In Case Size
1/2"	7/8"
5/8"	1 1/8"
7/8"	1 3/8"
1 1/8"	1 5/8"
1 3/8"	2 1/8"

- Take-offs to evaporators exit the bottom of the liquid line. Provide an expansion loop for each evaporator take-off (minimum 3 in. (76 mm) diameter).

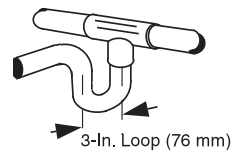
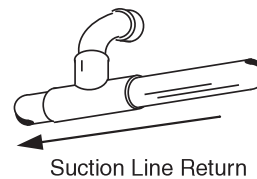

Liquid Line Take Off

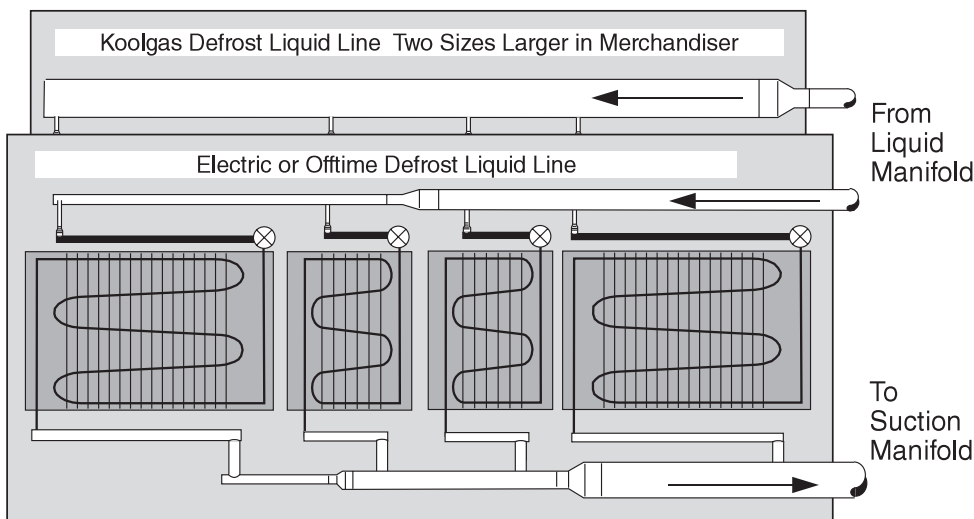

Excel Open Island and Wall

Installation Information

Twin-temperature Operation

Front to Rear Interconnects

The wide island merchandisers are factory equipped with separate piping and air systems for each compartment, and are thus all capable of twin-temperature operation. This is a standard feature. If the wide island merchandiser is to be run at a single temperature, factory installed piping interconnect kits are available.

Note:

A dual temperature kit adds components to allow a low temperature merchandiser to operate at medium temperatures, and switch between low and medium temperature operating conditions.

Twin temp. is used on low temperature wide island cases only and is the standard configuration. Twin temp. means each side of the island operates separately; thus one side might be set for ice cream conditions while the other side could be set for frozen food or ice cream. Only when both sides of a wide island lineup will always be used for the same operating conditions, should an interconnect piping kit be considered. Interconnect piping kits cannot be used with dual temperature kits. Contact Hussmann for further information.

Thermostats

Refrigeration Thermostat

The refrigeration thermostat body is located in the electrical wireway. The bulb, when factory installed, is located in the discharge flue. Wide Island models will have two thermostats – one on each side of the merchandiser.

Defrost Termination Thermostat

The standard disc type defrost termination thermostat is not adjustable. This thermostat is clamped to the coil inlet tube.

CDA Sensor (Optional)

Factory installed optional CDA sensor is located where the thermostat bulb would normally be located. Its leads will be routed through the electrical wireway and to the rack control panel. Leads are tagged in the wireway. Wide Island models will have two sensors—one on each side of the merchandiser.

Excel Open Island and Wall

Installation Information

Waste Outlet / Drain Line

Each merchandiser has two waste outlets. The waste outlets are located in front of the fan plenum 12 inches (305 mm) from either end of the merchandiser.

Depending on the model, tees with clean-outs, or elbows, are supplied for each merchandiser. One water seal is supplied for each merchandiser. The water seal must be installed with the waste outlets to prevent air leakage and insect entrance into the merchandiser.

Note: Splashguards must be installed before piping merchandiser.

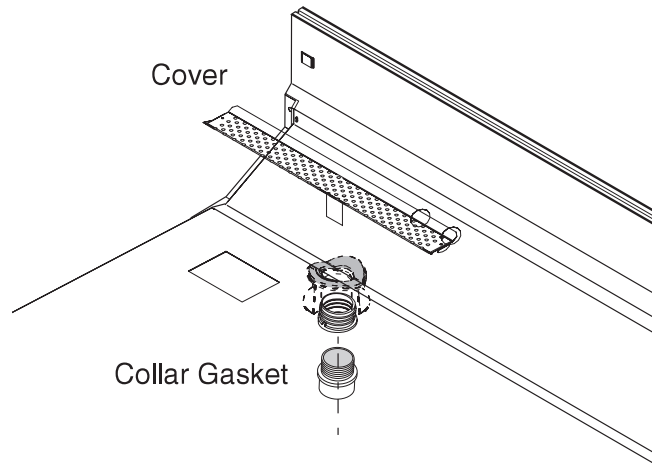

Items Factory Installed for Excel Waste Outlet on Each End of Case

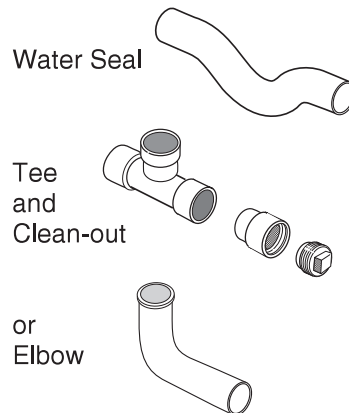
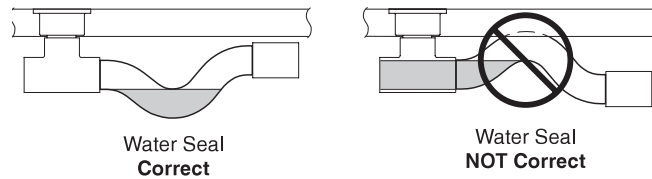

Factory Furnished Items To Be Installed

Excel Open Island and Wall

Installation Information

Installing Drip Piping

Poorly or improperly installed drip pipes can seriously interfere with the merchandiser's operation and result in costly maintenance and product losses.

Optional drip pipe arrangements are shown on the next page. Assemble the components using PVC specific threaded pipe sealer according to the manufacturer's direction.

Please follow the recommendations listed below when installing drip pipes to ensure proper installation.

1. Never use drip piping smaller than the nominal diameter of the pipe or water seal supplied with the merchandiser.
2. When connecting drip piping, the water seal must be used as part of the drip piping to prevent air leakage or insect entrance. Never use two water seals in series in any one drip pipe. Double water seals in series will cause an air lock and prevent draining.
3. Pitch the drip piping in the direction of flow. There should be a minimum pitch of 1/4 in. per ft (20 mm per 1 m).
4. Avoid long runs of drip piping. Long runs make it impossible to provide the pitch necessary for good drainage.
5. Ensure that drip piping is supported to relieve any stress on drip pipe connectors and drain hub.
 - a. Drip piping **MUST** be supported 24 inches from drain hub tee.
6. Provide a suitable air break between flood rim of the floor drain and outlet of drip pipe. To meet code requirements, it may be necessary to install a field-supplied drip pipe reducer. An alternative is to cut the last section of drip pipe at an angle.
7. Prevent drip pipes from freezing:
 - a. Do **NOT** install drip pipes in contact with uninsulated suction lines. Suction lines should be installed with a nonabsorbent insulation material.
 - b. Where drip pipes are located in dead air spaces, such as between merchandisers or between a merchandiser and a store wall, provide means to prevent freezing.



It is the installing contractor's responsibility to consult local agencies for local code requirements.

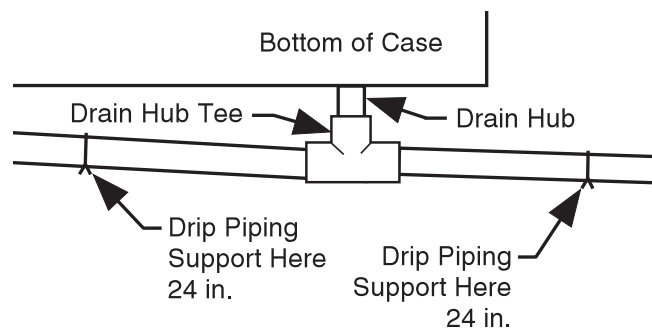

Excel Open Island and Wall Installation Information

Drip Piping Lineup Arrangements

The following illustrations below show typical arrangements for installing drip pipes for a lineup of merchandisers. Illustrations are for reference only. Piping may vary with location and access to hub drain(s). Each merchandiser waste outlet must be individually piped to a hub drain if 1/4 in. drip piping pitch cannot be maintained.

Note:

No more than two merchandisers are to be piped per water seal. Do not install water seal between two merchandiser waste outlets that are piped together (double water seals in series will cause an air lock and prevent drainage).

Optional Excel Drip Piping Arrangements

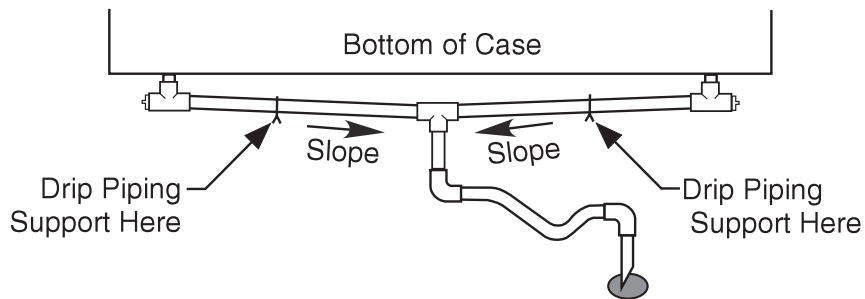

IT IS THE INSTALLING CONTRACTOR'S RESPONSIBILITY TO PROVIDE SUITABLE DRAINAGE.

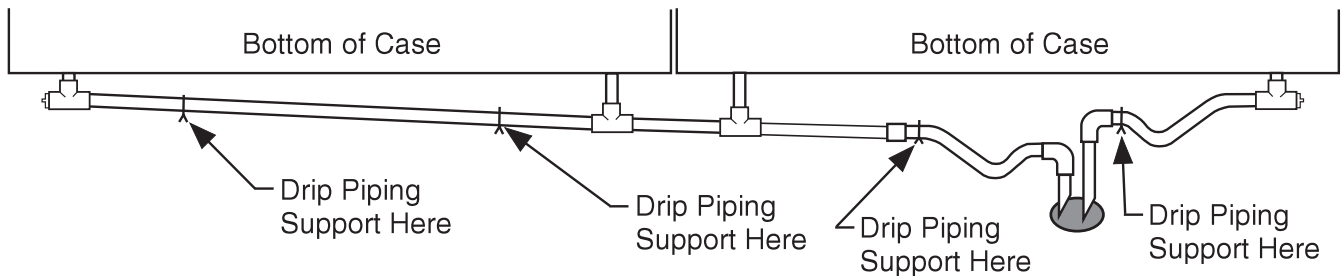

One Water Seal per Run of Drip Pipe
Always Slope Toward Floor Drain

Excel Open Island and Wall

Installation Information

Electrical Information

Electrical field wiring connects at the terminal block located in the raceway. Electrical requirements vary by case model. Refer to the technical data sheet for more information. Refer to the serial label(s) on the case to determine MCA and MOPD and to verify input voltage before making any electrical connections.

Merchandisers require dedicated electrical circuit(s) with ground. Consult equipment datasheet or equipment serial label for additional electrical specifications. Always use a dedicated circuit with the amperage stated on the equipment. Where components of multiple units are required to be wired to a single circuit, ensure that the load is distributed properly and proper disconnect locations are used. Do not overload the circuit.

It is necessary to allow for disconnection of the appliance from the supply power after installation. Disconnect power before servicing merchandisers.

If in doubt, consult an electrician.

Field Wiring

Components are wired as completely as possible at the factory with all work completed in accordance with the National Electrical Code (NEC). All deviations required by governing electric codes will be the responsibility of the installer. All wiring must be in compliance with governing electrical codes.

Field wiring must be sized for component amperes stamped on the serial label. Actual ampere draw may be less than specified. When multiple display cases are on the same defrost circuit, the defrost termination thermostats are wired in series.

WARNING: Always check the serial label for component amperes.

Based on the full load amps of the system, select the largest connectible wire size (based on no more than three wires in the wireway and 86° F (30° C) environment per NEC).

Electrical Connections

All wiring must be in compliance with NEC and local codes. All electrical connections are to be made at a terminal block, in the electrical wireway, or in a handy box.

Identification of Wiring

Leads for all electrical circuits are identified by colored plastic bands. These bands correspond to the color code sticker (shown below) located inside the merchandiser wireway. Terminal block is not for case-to-case connection.

WIRING COLOR CODE	
Leads for all electrical circuits are identified by a colored plastic band: neutral wire for each circuit has either White insulation or a White plastic sleeve in addition to the color band.	
PINK	REFRIG. THERMOSTAT LOW TEMP.
LIGHT BLUE	REFRIG. THERMOSTAT NORM TEMP.
DARK BLUE	DEFROST TERM. THERMOSTAT
PURPLE	CONDENSATE HEATERS
BROWN.....	FAN MOTORS
GREEN*	GROUND
ORANGE OR TAN	LIGHTS
MAROON	RECEPTACLES
YELLOW*	DEFROST HEATERS 120V
RED*	DEFROST HEATERS 208V

*Either colored sleeve or colored insulation

Electrician's note: Use copper conductor wire only.

- Case must be grounded.
- These are marker colors wires may vary.

Excel Open Island and Wall

Installation Information

Refrigerant Charging Procedure

Only the specified refrigerant type can be used.

The triple evacuation method should be used to achieve a leak-free, dry system. For the first evacuation, the system should be pulled down to 1,000 microns. The second evacuation should be pulled to 500 microns. The final evacuation should be pulled down to at least 300 microns. A dry, leak-free system is when the system holds a vacuum of 300 microns for 24 hours with the vacuum pump de-energized and valved off. Between each evacuation, break the vacuum with dry nitrogen.

When connecting hoses between the refrigeration system, manifold gauges, and refrigerant cylinder, ensure that the connections are secure and there are no potential sources of ignition nearby. Ensure that contamination of different refrigerants does not occur when using charging equipment.

Use dedicated hoses to service the type of refrigeration system being serviced (e.g., R-454C equipment for an R-454C system). Hoses or lines should be as short as possible to minimize the amount of refrigerant contained in them.

Ensure that the refrigeration system is properly grounded prior to charging the system with refrigerant, to avoid the potential for static build-up.

In addition to conventional charging procedures, the following requirements shall be followed:

- a. Ensure that contamination of different refrigerants does not occur when using charging equipment. Hoses or lines shall be as short as possible to minimize the amount of refrigerant contained in them.
- b. Cylinders shall be kept in an appropriate position according to the instructions.
- c. Ensure that the REFRIGERATING SYSTEM is earthed prior to charging the system with refrigerant.
- d. Label the system when charging is complete (if not already).
- e. Extreme care shall be taken not to overfill the REFRIGERATING SYSTEM.

Prior to recharging the system, it shall be pressure-tested with the appropriate purging gas. The system shall be leak-tested on completion of charging but prior to commissioning. A follow up leak test shall be carried out prior to leaving the site.

Extreme care must be taken not to overfill the refrigeration system. After charging, carefully disconnect the hoses, attempting to minimize the quantity of refrigerant released. Further leak check the service ports, hoses, refrigerant tanks. Original service port washer and cap must be reinstalled to prevent refrigerant leaks. Cap must be tightened to 12–14 in-lb (1.4–1.6 nm) torque.

Refrigerant Charge Label

After charging is complete, note the refrigerant type and charge amount using permanent marking on the refrigerant charge label affixed to the unit.

Refrigerant	Charge
R- _____	_____ lbs

Excel Open Island and Wall

Installation Information

Pumped Liquid R-744 (CO₂) Start-Up Checklist

1. When the system(s) are ready for commissioning. Visually check all components. Check pressure and vacuum sheets complete. See Report #1A and #1B later in the document.
2. Load and check the controller's program and verify all Inputs and Outputs.
3. Main power available. Check for three-phase at sub-board. Connections tight on board. Compressors isolated. Check all cabinets (fans) clear of rubbish and that all electrical grounds have continuity and electrical tests have been completed by electrician.
4. Turn on power and check operation of cabinet and room fans, lights trim, heaters, door heaters, defrost heaters, drain heaters and all isolating switches. Start crank case heaters to warm oil.
5. Check individual breakers / fuse to prove circuits of all safety switches on refrigeration system, (HP/LP, oil failure). Compressor and condenser overloads for correct operation and set points, oil heaters and oil levels. All valves fully open. See Report #2 later in the document.
6. Start primary side compressors individually and check for correct three phase power and current draw. Charge up primary system. Open hot gas bypass lines to impose a load on the primary system during initial startup. Shut off hot gas bypass lines after system is charged.
7. Charge R-744 (CO₂) vessel initially with VAPOR until pressure is above 100 PSIG (6.9 bar), then continue charging with liquid. Charge with liquid until high liquid level sensor in the receiver senses liquid.
Note: Only one liquid CO₂ Pump may run at any given time. Shut off either the supply or return ball valve to the pump that is not in use. Dual pump operation—alternating pumps is not recommended by the pump manufacturer.
8. Start the liquid CO₂ pump. Then commence branch cooling in a staged basis of one branch at a time taking care to ensure that the CO₂ vessel pressure does not rise above 400 PSIG (27.6 bar)—do not rush this initial start-up stage, and do not run the CO₂ system until the high side system is fully operational.
Note: Do not open all solenoid valves at once. Run high side plant and check (adjust if necessary) superheats and operation of interstage heat exchanger.
9. Check cabinet and room temp setting, including cut in and cut out operation. Confirm the operation of the CO₂ leak detectors and alarm system.
Note: CO₂ leak detectors are to be located in every cooler room, freezer room, food preparation area, plant room and the retail area (as required by code).
10. Check defrost (and current draw on elements) operation and safety termination for each individual branch.
11. Check oil temps / pressures and high pressure / low pressure, pressures, and settings.
12. Check and record running amperages of compressors and condensers. Check moisture indicator.
13. Check and record operational amperages of all electrical loads (i.e., fans, lights, anti-sweat heaters, defrost heaters, etc.)
14. Turn off plant and recheck all electrical terminals for tightness or signs of overheating.
15. Check alarm system operation and settings.
16. After 100 hours of running on the primary system change: drier cores, suction filter cores, lubricant, and replace oil filters / strainers on the secondary system change: liquid line and dryer cores
17. Note: Maintenance requires these drier cores be replaced whenever the system is opened or at a minimum of every six months.
18. Leak test system and re-check electrical terminals. Re-check cabinet and room temp settings; including cut in and cut out operation.
19. Full training and the onsite Instruction Manual are to be provided by the refrigeration contractor to the employer's key (nominated) onsite store staff prior to the store opening date. This must include detailed safety training with particular attention to CO₂.

Excel Open Island and Wall

Installation Information

Pumped Liquid R-744 (CO₂) Operation

Sequence of Operation

This section describes the general operation of the R-744 liquid recirculation secondary systems. These systems are designed to be used in conjunction with a centralized parallel compressor rack system. The R-744 liquid recirculation system regulates case temperatures by circulating carbon dioxide through a case evaporator as it absorbs heat. The returning carbon dioxide is cooled to a liquid by the primary refrigerant supplied from the rack. The carbon dioxide is then pumped back through the case evaporator.

When the secondary system control circuit is powered up (120 volts) the chiller controller is powered. This controller regulates superheat on the primary side and must be programmed before starting the refrigeration system.

Turn on the main on/off switch to energize the pump. One pump will be "ON," and one pump will be "OFF" as a backup pump. The pump that is "ON" will now run continuously. The R-744 receiver pressure and temperature is controlled by stepping the primary rack compressor capacity.

The rack stages compressors on and off based on the input from R-744 receiver pressure transducer. The EEV controller will regulate the superheat on the primary refrigerant side.

Defrost is initiated when the rack controller sends a signal to de-energize a case solenoid valve. The solenoid valve closes, and after a specified time delay, electric heat is switched on. Once the defrost period has elapsed, the electric heat is switched off. After a second time delay, the solenoid valve is energized. The R-744 (CO₂) refrigerant then resumes flow through the case.

Commissioning Checklist: https://www.hussmann.com/ns/Supplemental_IO/GD_Pumped_Liquid_R-744_CO2_Commissioning_Checklist_M001264.pdf

CO₂ Temperature Control

The CO₂ temperature is controlled by using the CO₂ receiver pressure as the reference point for the primary side compressor capacity.

Read CO₂ Receiver Pressure Control

Pressure Rise

IF

CO₂ receiver pressure rises 2 PSIG (0.1 bar) above the saturation pressure for the selected CO₂ setpoint temperature,

THEN

Rack controller increases the primary-side compressor capacity until the set point temperature CO₂ saturation pressure is reached.

Pressure Drop

IF

CO₂ receiver pressure falls 2 PSIG (0.1 bar) below the saturation pressure for the selected CO₂ setpoint temperature,

THEN

Rack controller decreases the primary-side compressor capacity until the set point temperature

Excel Open Island and Wall

Installation Information

Shutdown Modes

Low Pump Differential Pressure (PSIG [bar])

The rack controller (e.g., Copeland E3) monitors the discharge and suction pressure across the CO₂ pump that is “ON” and calculates the differential pressure using a flex combiner.

There will be dual pumps operating in parallel. One pump will be “ON” running continuously, and one pump will be “OFF” as a backup. There is a switch on the control panel to switch between Pump 1 or Pump 2. The two pumps will have different sets of discharge and suction pressure transducers.

Operation when pressure is in range:

IF

the differential pressure (psi [bar]) across the pump is greater than 5 psi (0.3 bar) or less than 60 psi (4.1 bar),

THEN

Rack controller sends output to turn the pump ON.

Operation when pressure is out of range:

IF

the differential pressure (psi [bar]) across the pump drops below 5 psi (0.3 bar) for a period of 10 seconds,

OR

IF

the differential pressure (psi [bar]) across the pump rises above 60 psi (4.1 bar) for a period of 10 seconds,

THEN

Rack controller sends output to turn the pump OFF. Rack controller sends alarm to identify “LOW PUMP DIFFERENTIAL PRESSURE SHUT DOWN.” After a 2-minute time delay, Rack controller sends output to turn the pump ON.

Multiple Restart and Lockout Procedure

IF

2nd shutdown is within 15 minutes,

THEN

re-start after time delay of 2 minutes.

IF

3rd shutdown is within 15 minutes,

THEN

re-start after time delay of 2 minutes.

IF

4th shutdown within 15 minutes,

THEN

lockout and require an inspection by service technician.

Excel Open Island and Wall

Installation Information

Safety Shut-Off Valves (A2L only)

- Safety shut off valves are factory-installed on each case. Do not bypass safety shut off valves.
- Safety shut-off valves shall not block in liquid refrigerant unless adequate relief is provided to the refrigerant system low pressure side.
- Safety shut-off valves are located in such a way such that leaks upstream of the safety shut-off valve shall not enter the internal volume of the partial unit and in a space with a room volume large enough so that the maximum refrigerant charge complies to the limit for releasable charge.
- Safety shut-off valves are positioned to enable access for maintenance by an authorized person.
- The safety shut-off solenoid valve(s) are located underneath the case as shown in Detail A below. For End cases, the safety shut-off valve is only located (one side) on the end of the case.

FWEG model shown from underneath the case. Other F-Series models have similar shut-off valve locations.

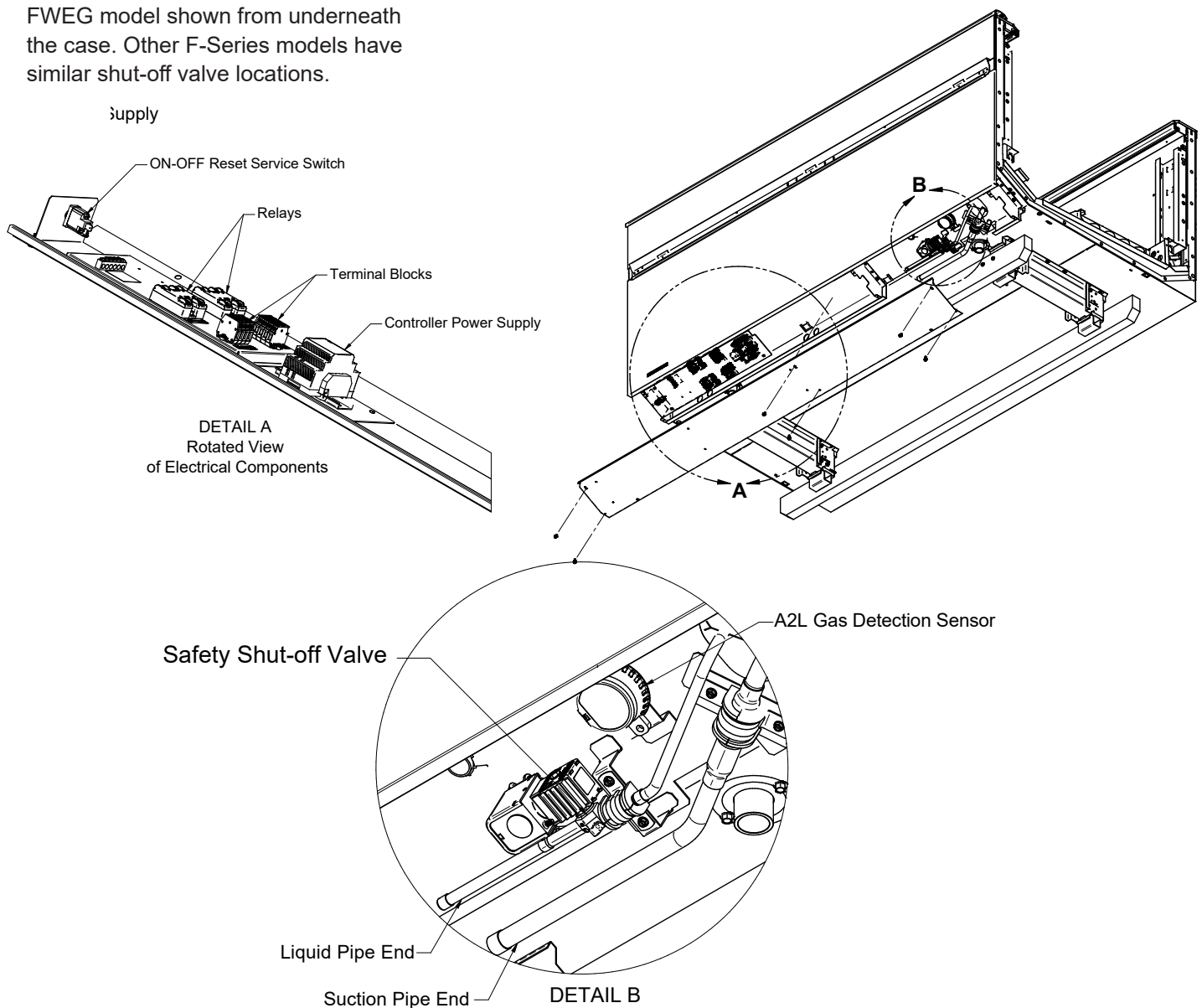

Excel Open Island and Wall

Installation Information

Pumped Liquid R-744 (CO₂) Case Inlet Solenoid Valve

The 120 VAC case inlet solenoid valve is normally closed and must receive a signal from the rack or case controller to provide temperature control. The solenoid valve must shut off (de-energize) during defrost and when case discharge air temperature is satisfied. Settings are provided on the CO₂ application data sheets for each specific case model.

Differential of the controller must be set to 2° F (1.1° C) or less to avoid large fluctuations in discharge air temperature. A swing of as much as 5° F (2.8° C) total (+/-2.5° F [1.4° C]) will not affect product temperatures.

Liquid line solenoid lead wires are terminated in the raceway and marked with an identification tag or connected to a factory installed case controller.

Load Limits

The product racks are rated for 47.5lb/sqft (21.5 kg) capacity. Exceeding this load can cause damage to the racks, case, damage to store products, and potentially create a hazardous condition for customers and store personnel. Each merchandiser has a load limit decal. Product must be within designated load limit to ensure proper refrigeration and air curtain performance. Product racks should be loaded so that the product does not extend above the load limit decal. Product loaded above the decal will interfere with air circulation in the cabinet.

Shelf life of perishables will be short if load limit is violated. Overstocking will adversely affect product temperature and merchandiser efficiency. The load limit is the bottom of the interior panel break. Recommended load limit profiles are shown below.

Product should not be placed in merchandisers until merchandiser is at proper operating temperature. Proper rotation of product during stocking is necessary to prevent product loss. Always bring the oldest product to the front and set the newest to the back.

- Air discharge and return flues must remain open and free of obstruction at all times to provide proper refrigeration and air curtain performance.
- Do not allow product, packages, signs, etc. to block these grilles.
- Do not use non-approved shelving, baskets, display racks, or any accessory that could hamper air curtain performance.

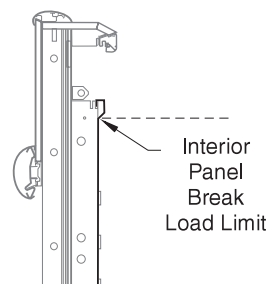

Product Stocking

In addition to the prior recommendations for spacing, product should always be maintained at proper temperature. This means the temperature of the product must be controlled from the time the product is received through storage, preparation, and display to maximize the life of the product.

Product should not be placed inside the merchandisers until merchandisers are at proper operating temperature. Allow merchandiser 24 hours to operate before loading product. Proper rotation of product during stocking is necessary to prevent product loss. Always bring the oldest product to the front and set the newest to the back.

- Air discharge and return flues must remain open and free of obstruction at all times to provide proper refrigeration and air curtain performance.

Excel Open Island and Wall

Installation Information

Thermometer

NSF 7 and US FDA Food Code Required Thermometer

Important — Please read before stocking unit.

Thermometer (part number 0443314) is provided in response to United States Food and Drug Administration Food Code [www.fda.gov] and NSF/ANSI Standard 7 [www.nsf.org]. Questions about either code should be addressed to local agencies or other appropriate officials.

Each installation will be different depending on how the unit is stocked, shopping patterns in the department, and ambient conditions of the store. The suggested locations provided herein are possible locations. It is the responsibility of the purchaser/user to determine the location within the food storage area of the case that best meets the code requirements of US FDA and NSF.

The thermometer may need to be moved several times to find the warmest location. Mounting options include flexible plastic for price tag molding application, magnet applied to back of flexible plastic for steel end wall, and double-sided tape. If tape is used, tape must not be exposed after installation.

Suggested Possible Thermometer Locations

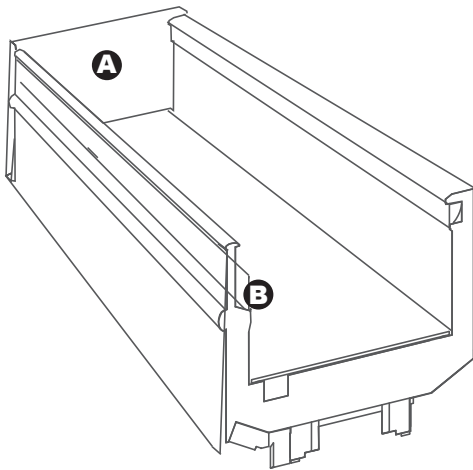

Location A: On inside of end panel

Location B: On package guard, facing out with glass front and on inner, front panel with solid front

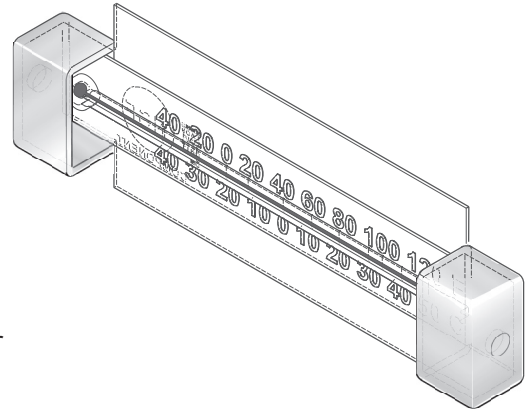

Excel Open Island and Wall Installation Information

Offsetting Bumper

Offsetting the bumper helps to disguise the joint locations, giving the lineup a smoother look.

Note:

The Excel low temperature case bumpers are directional. Look for an arrow inside the bumper.

Bumper Removal

Although bumpers can usually be removed by hand, a simple tool to remove bumpers can be created by wrapping tape over the claw of a small pry bar as shown here. The pry bar is available at most local hardware stores.

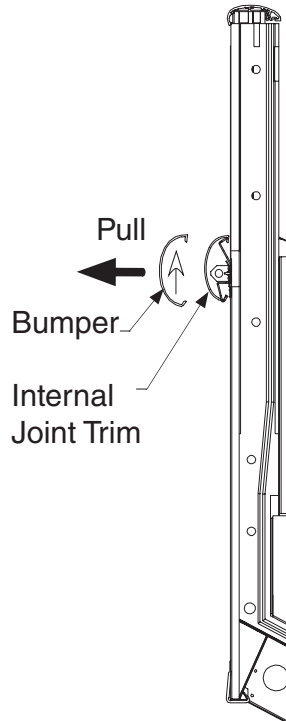

Place the padded pry bar below the bumper as shown below. The tape/padding lessens the chance of damaging the color panel.

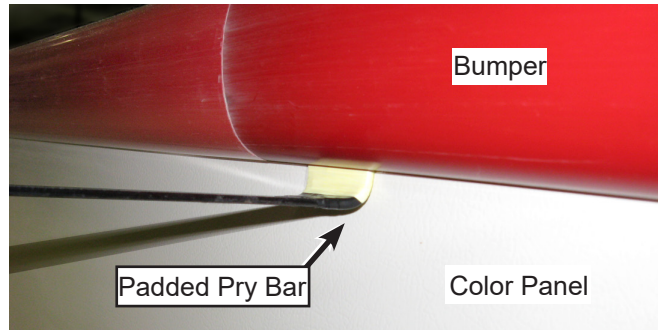

Do not use a screwdriver or other sharp object, which will damage bumper and color panel.



DO NOT USE SHARP OBJECT



Excel Open Island and Wall Installation Information

These merchandisers have sheet metal retainers with joining brackets. Bumper retainers may be removed, or adjusted by removing bumper, color panels and bumper retainer screws.

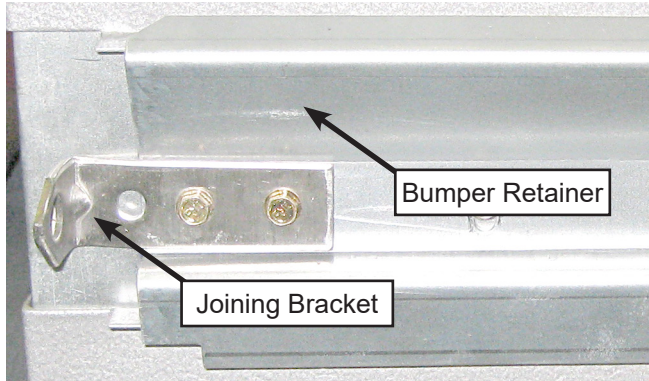

Cases with rubber bumper retainers may be removed by lifting the end as shown below.

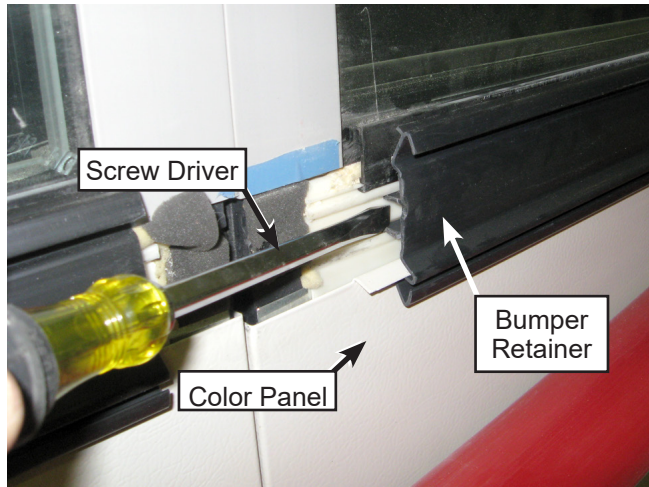

Prying on the long edges is likely to damage the retainer.



For merchandisers with rubber retainers and glass fronts, replace retainer as shown below using a scrap block of lumber and a rubber mallet. One person should hold the retainer in alignment while another taps it into place.

Excel Open Island and Wall

Installation Information

Offsetting Bumper (for End Merchandisers)

1. Locate starter bumper shipped with the left-end kit.
2. Remove factory installed bumper by pulling bumper away from bumper retainer. Be careful not to lose the internal joint trim on the bumper.
3. Starting at the left end of the lineup, install the bumper starter section first. To install:
 - a. Position internal joint trims so that the first is flush to the left-end panel and the second is centered between the starter bumper and the full-length bumper as shown.
 - b. Install full-length bumpers and internal trims offset across joints. Make sure that no gaps exist between sections. Continue installing the bumpers the length of the lineup.
4. Once all except the last section of bumper have been installed, refrigerate the merchandiser lineup for at least six hours. The last section of bumper should be kept inside a cooler or refrigerated merchandiser during this time. This will allow the bumper to contract.
5. Go to the right end of the lineup and tap the bumper to close any gaps.
6. Measure and cut last section of bumper. Use a miter box and fine-tooth saw to cut last bumper to length. Install the last section.
7. Remove protective film from bumper once installation is complete.

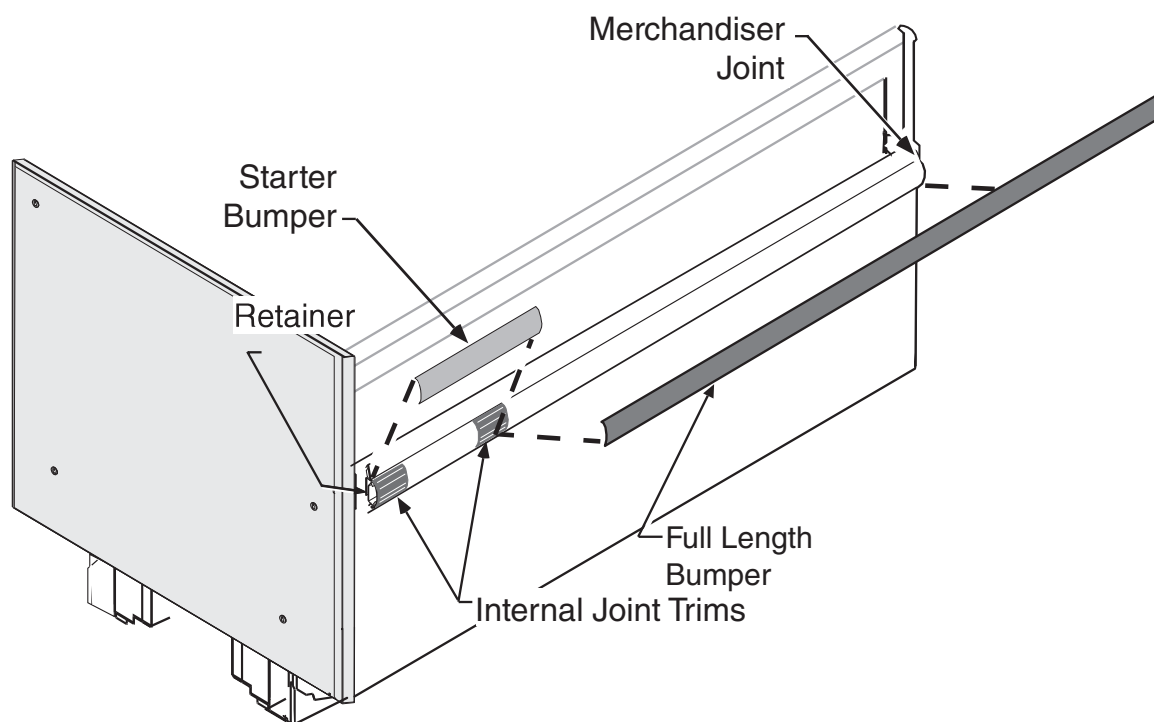
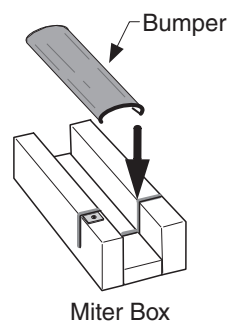

Excel Open Island and Wall

Installation Information

Offsetting Bumper (for Merchandiser Lineup)

1. Locate bumpers for the sides of the lineup. The bumpers are shipped with the merchandisers.
2. Refrigerate the merchandiser lineup for at least six hours. The offsetting bumpers sections should be kept inside a cooler or refrigerated merchandiser during this time. This will allow the bumper to contract and provide for a good fit and finish.
3. To install offsetting bumpers:
 - a. Remove bumpers from cooler. Measure bumpers and cut to appropriate length. Use a miter box and fine-tooth saw.
 - b. Insert internal joint trims first. Install bumpers offset across joints along the side of the lineup as shown in the illustration below. Joint trim provides stability for the bumpers, and lends to a smooth fit and finish.
4. Make sure no gaps exist between sections at each end of field cut bumpers.
5. Verify fit and finish at both sides of corner extrusion. If bumpers are cut too long, the corner extrusion may bow out, resulting in an unattractive finish.
6. Remove protective film from bumper once installation is complete.

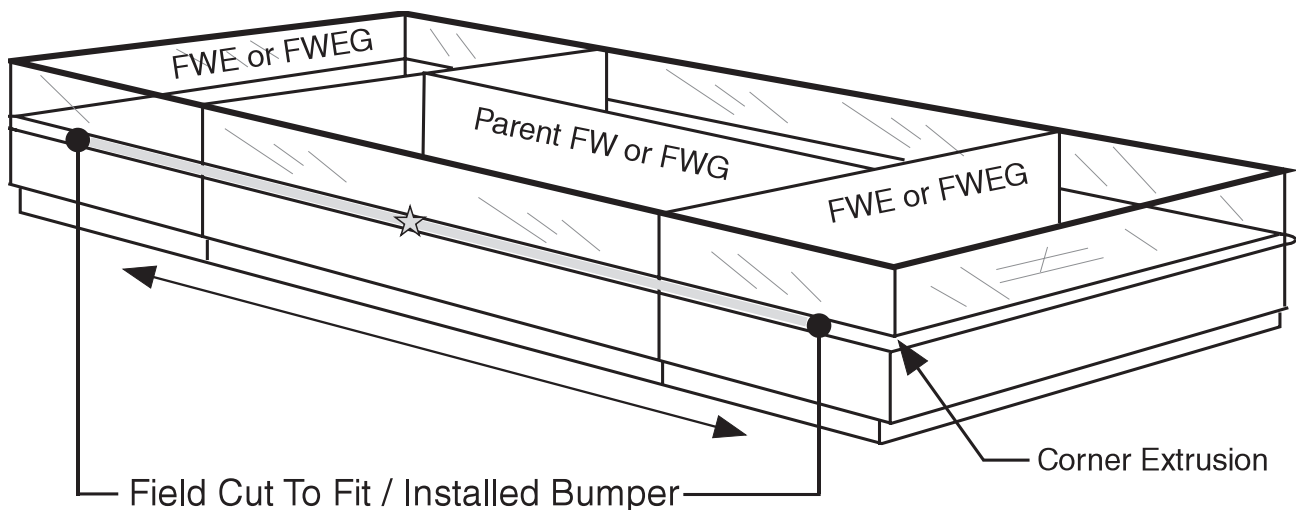
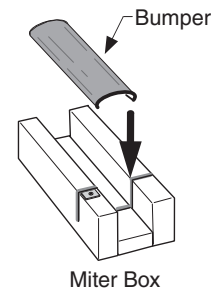
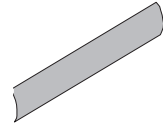

Excel Open Island and Wall

Installation Information

Offsetting Plastic Top Rail

Offsetting the plastic top rail helps to disguise the joint locations, giving the lineup a smoother look.

If factory installed, carefully remove all plastic top rails in the lineup. Do not damage the top rail retainer.

1. Refer to (1) in illustration below. Install a 1-ft starter section flush against the corner trim at the left end of the lineup.
2. Refer to (2) in illustration below. Re-install a 38-inch section removed earlier from the end merchandiser. Place it flush against the starter, without any gaps.
3. Refer to (3) in illustration below. Install a full-length top rail, leaving no gaps. Continue installing the top rails the length of the lineup. Once all except the last section of top rail have been installed refrigerate the merchandiser lineup for at least six hours. The last section of top rail should be kept inside a cooler or refrigerated merchandiser during this time. This will allow the top rail to contract.
4. Go to the right end of the lineup and tap the top rail to close any gaps.
5. Refer to (4) in illustration below. Measure and cut last section of top rail. Use a miter box and fine-tooth saw to cut last top rail to length. Install the last section.
6. Remove protective film from top rail once installation is complete.

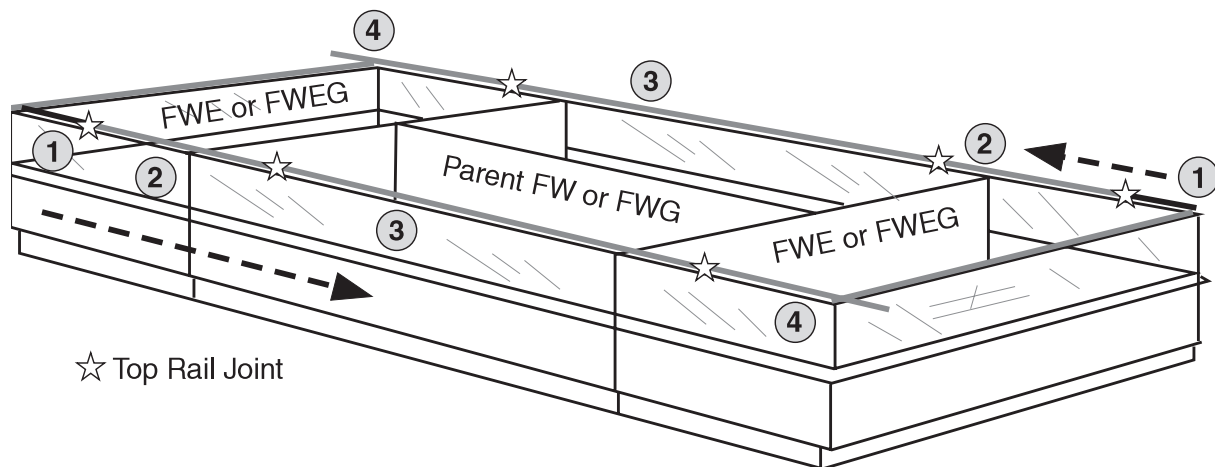

Excel Open Island and Wall

Installation Information

If top rails are not factory installed,

1. Begin by installing a 48-inch top rail against the corner trim of the LH end case. Refer to (1) in the illustration below.
2. Install a second 48-inch top rail against the corner of the RH end merchandiser. Refer to (2) in the illustration below.
3. Once all except the last section of top rail have been installed refrigerate the merchandiser lineup for at least six hours. The last section of top rail should be kept inside a cooler or refrigerated merchandiser during this time. This will allow the top rail to contract.
4. Tap the top rail to close any gaps.
5. Measure the center section, (3) in illustration below, and cut Top Rail to fit. Use a miter box and fine-tooth saw to cut last top rail to length. Install the last section.
6. Remove protective film from top rail once installation is complete.

Optional Stainless Steel Top Rail Trim

Stainless steel top rails are not offset. Install trim at each joint as indicated below.

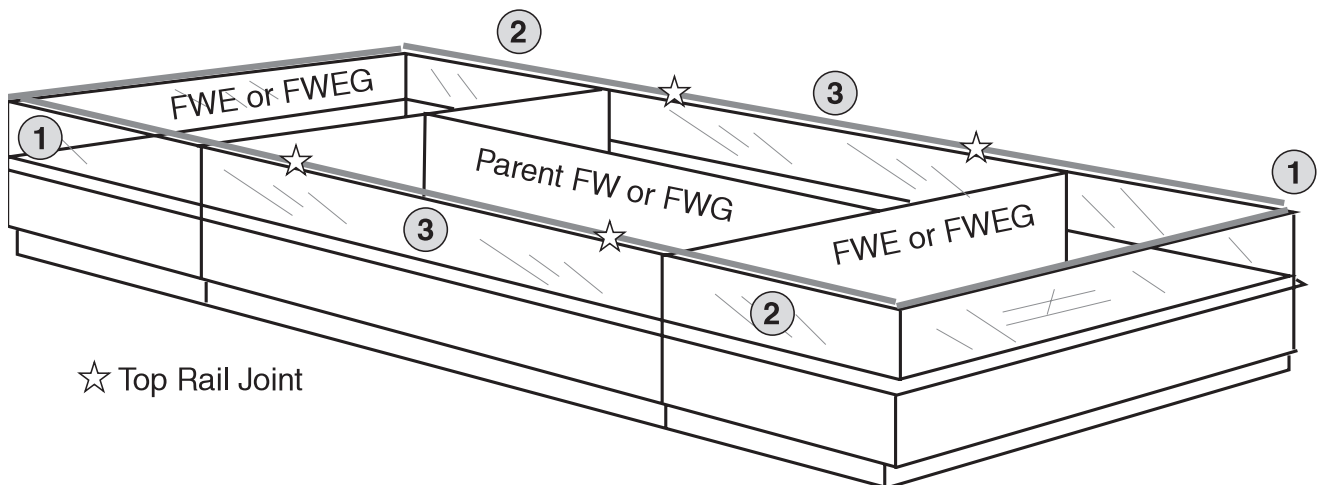
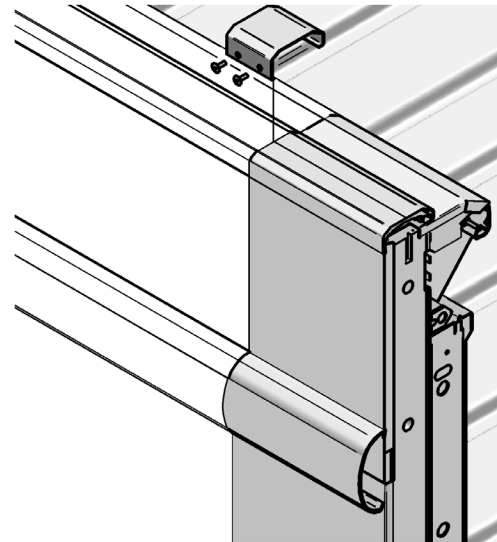

Excel Open Island and Wall Installation Information

Installing Splashguards

The splashguard is shipped inside each merchandiser. After merchandisers have been leveled and joined, and all drip piping, electrical and refrigeration work has been completed, install the splashguard(s), or splashguard fan(s) for cases with A2L refrigerant. End splashguards are addressed on the following page.

To Install Splashguards:

1. Check to be sure that all splashguard brackets are level with the floor.
2. Position top of splashguard with the top angled in as shown in the illustration. Align the slots in the upper edge of the splashguard with the tabs extending downward behind the splashguard cover.
3. Engage the slots over the tabs and raise the splashguard while pushing the bottom in.
4. Align the tabs on the splashguard brackets with the slots in the bottom edge of the splashguard. Engage the tabs in the slots and drop the splashguard into place.

To install the cove trim to the splashguard:

Remove all dirt, wax and grease from the area of the splashguard where adhesion will be necessary to ensure a secure installation.

Apply a good contact cement to the cove trim and allow proper drying time according to the directions supplied with the cement.

Install the trim to the splashguard so that it is lying flush with the floor. Do not seal the trim to the floor.

If required by local health codes the Cove Trim may be sealed to the floor, using a silicone type sealer. Sealant must be removed and replaced when servicing.

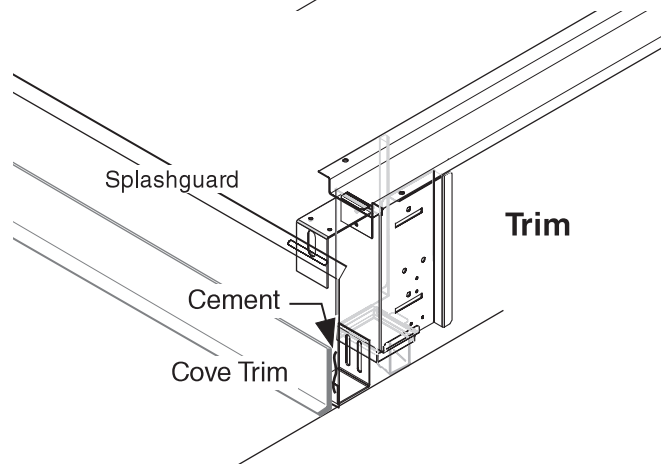
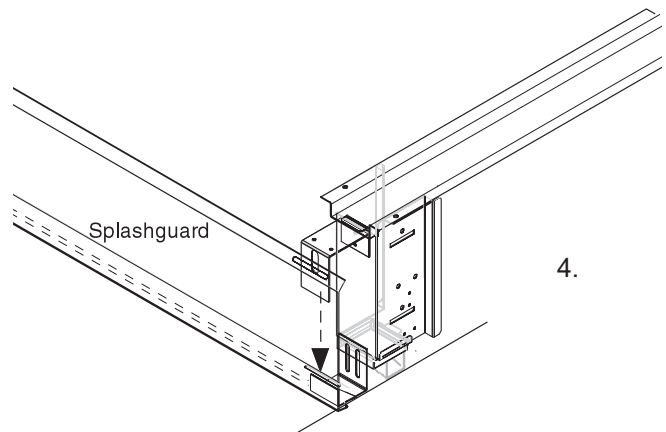
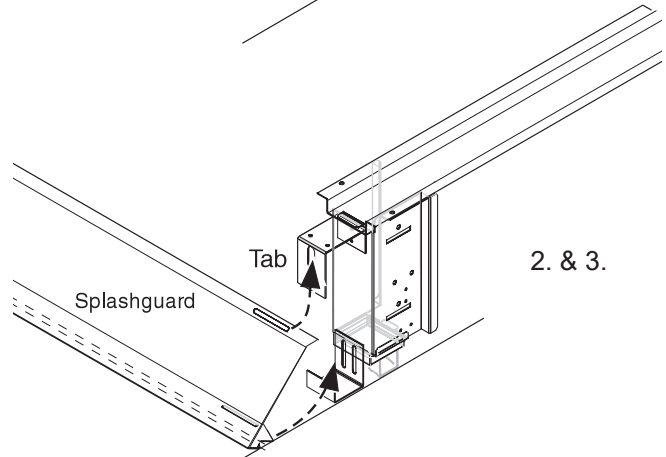
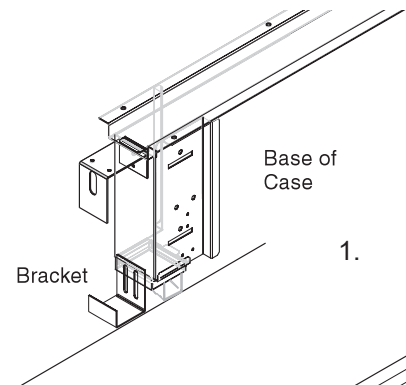

Excel Open Island and Wall

Installation Information

Installing Splashguard Fans (A2L only)

(Retainers and Panels)

Splashguard fans are shipped with F-Series cases that utilize A2L refrigerants. Splashguard fans must be installed in order for the case to operate. These fans are always off during normal operation, and turn on if an A2L leak is detected.

To Install Splashguard Fans:

1. Check to be sure that all splashguard brackets are level with the floor. Refer to previous page illustrations. Splashguard fan is installed similar as the splashguard.
2. Position top of splashguard fan assembly with the top angled tabs onto the slots. Align the slots in the upper edge of the splashguard with the tabs extending downward behind the splashguard cover.
3. Engage the slots over the tabs and raise the splashguard while pushing the bottom in.
4. Install splashguard fan assembly. Connect the fan harness to the receptacle harness under the case. Slide splashguard fan assembly over the retainer.
5. Align the tabs on the splashguard fan brackets with the slots in the bottom edge of the fan splashguard. Engage the tabs in the slots and drop the splashguard into place.
6. Confirm the splashguard fan assembly and harness is firmly attached, unobstructed, and operational.

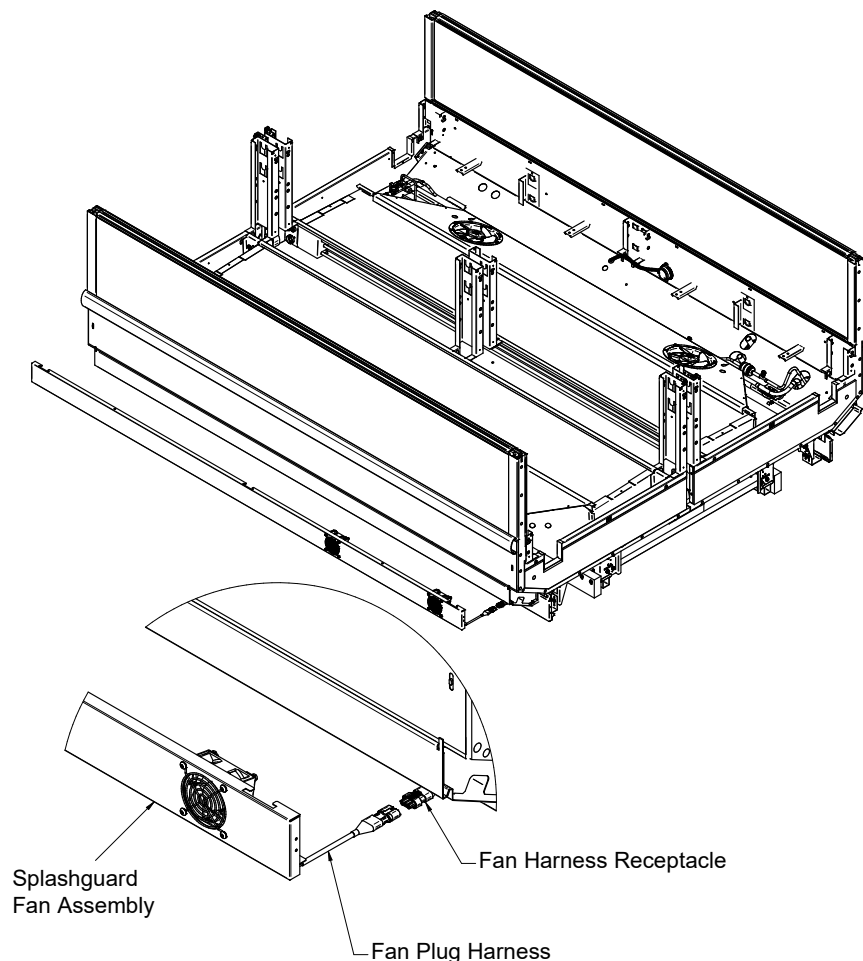

Excel Open Island and Wall

Installation Information

Installing Splashguard on End and End Case

An end splashguard ships with each end assembly. End case splashguards ship with the case. Install end splashguards after main splashguards.

1. Check to be sure that all splashguard brackets are level with the floor.
2. Position top of splashguard with the top angled in, behind the lower panel bracket.
3. Raise the splashguard enough to align the tabs on the splashguard brackets with the slots in the bottom edge of the splashguard. Engage the tabs in the slots and drop the splashguard into place.

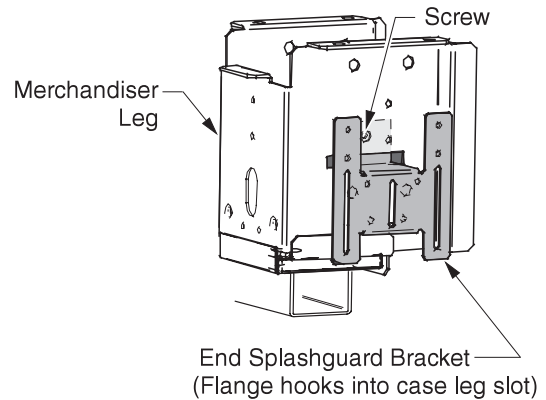

Cove trim may be added in the same way as for the main splashguards.

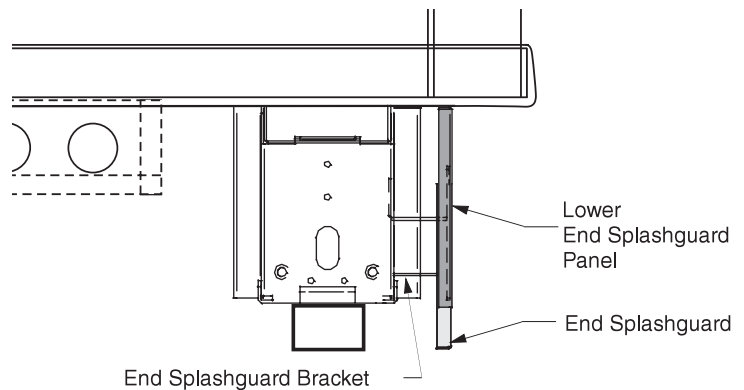

End Case Splashguards Installed

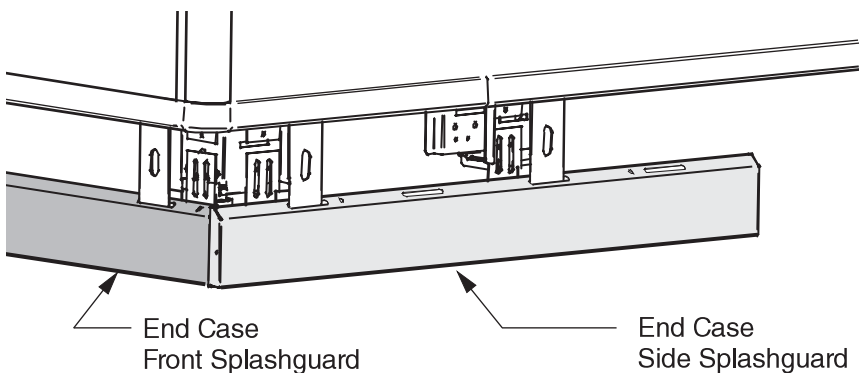

Excel Open Island and Wall

Maintenance and Service

WARNING

READ ALL WARNINGS AND PROCEDURES IN THIS MANUAL AND ON THE EQUIPMENT BEFORE SERVICING OR PERFORMING MAINTENANCE ON THIS EQUIPMENT.

FAILURE TO ABIDE BY THESE WARNINGS COULD RESULT IN AN EXPLOSION, DEATH, INJURY, AND PROPERTY DAMAGE.

Checks and Repairs for A2L Equipment

Prior to beginning work on systems containing flammable refrigerants, safety checks are necessary to ensure that the risk of ignition is minimized.

- Work shall be undertaken under a controlled procedure, as documented below, to minimize the risk of a flammable gas or vapor being present while work is being performed.
- Prior to performing any service work, make sure all tools and equipment have been certified for use with flammable refrigerants.
- All maintenance staff and others working in the local area shall be instructed on the nature of work being carried out. Work in confined spaces shall be avoided.
- The area shall be checked with an appropriate refrigerant detector prior to and during work, to ensure the technician is aware of potentially toxic or flammable atmospheres. Ensure that the leak detection equipment being used is suitable for use with all applicable refrigerants, i.e., non-sparking, adequately sealed, or intrinsically safe.
- If any hot work is to be conducted on the refrigerating equipment or any associated parts, appropriate fire extinguishing equipment shall be available on hand. A dry chemical or CO₂ fire extinguisher should be adjacent to the charging area.
- No person carrying out work in relation to a refrigerating system which involves exposing any pipe work shall use any sources of ignition in such a manner that it may lead to the risk of fire or explosion. All possible ignition sources, including cigarette smoking, should be kept sufficiently far away from the site of installation, repairing, removing and disposal, during which refrigerant can possibly be released to the surrounding space. Prior to work taking place, the area around the equipment shall be surveyed to make sure that there are no flammable hazards or ignition risks. "No Smoking" signs shall be displayed.
- Ensure that the area is in the open or that it is adequately ventilated before breaking into the system or conducting any hot work. A degree of ventilation shall continue during the period that the work is carried out. The ventilation should safely disperse any released refrigerant and preferably expel it externally into the atmosphere.
- The following checks shall be applied to installations using flammable refrigerants:
 - i. The actual refrigerant charge is in accordance with the room size within which the refrigerant containing parts are installed.
 - ii. The ventilation machinery and outlets are operating adequately and are not obstructed.
 - iii. If an indirect refrigerating circuit is being used, the secondary circuit shall be checked for the presence of refrigerant.
 - iv. Marking to the equipment continues to be visible and legible. Markings and signs that are illegible shall be corrected.
 - v. Refrigerating pipe or components are installed in a position where they are unlikely to be exposed to any substance which may corrode refrigerant containing components, unless the components are constructed of material which are inherently resistant to being corroded or are suitably protected against being so corroded.
- Where electrical components are being changed, they shall be fit for the purpose and to the correct specification. At all times, the manufacturer's maintenance and service guidelines shall be followed. If in doubt, consult the manufacturer's technical department for assistance.

Excel Open Island and Wall

Maintenance and Service

- During repairs to sealed components, all electrical supplies shall be disconnected from the equipment being worked upon prior to any removal of sealed covers, etc. If it is absolutely necessary to have an electrical supply to equipment during servicing, then a permanently operating form of leak detection shall be located at the most critical point to warn of a potentially hazardous situation. Particular attention shall be paid to the following to ensure that by working on electrical components, the casing is not altered in such a way that the level of protection is affected. This shall include damage to cables, excessive number of connections, terminals not made to the original specification, damage to seals, incorrect fitting of glands, etc.
 - i. Ensure that the apparatus is mounted securely.
 - ii. Ensure that seals or sealing materials have not degraded to the point that they no longer serve the purpose of preventing the ingress of flammable atmospheres. Replacement parts shall be in accordance with the manufacturer's specifications.
- Intrinsically safe components are the only types that can be worked on while live in the presence of a flammable atmosphere. The test apparatus shall be at the correct rating. Replace components only with parts specified by the manufacturer. Other parts can result in the ignition of refrigerant in the atmosphere from a leak.
- Any vacuum used for cleaning coils should be approved for flammable refrigerants.

Checks and Repairs for R-744 (CO₂) Equipped Equipment

- Replacement parts must be compatible with the specific equipment's maximum design pressure as shown on the equipment labeling. For example, if the equipment has been designed to meet 1,305 psig (90 bar) maximum design pressure then any replacement part must be 1,305 psig (90 bar) compatible.

Checks and Repairs for All Equipment

- Repair and maintenance to electrical components shall include initial safety checks and component inspection procedures. If a fault exists that could compromise safety, then no electrical supply shall be connected to the circuit until it is satisfactorily dealt with. If the fault cannot be corrected immediately but it is necessary to continue operation, an adequate temporary solution shall be used. This shall be reported to the owner of the equipment, so all parties are advised. Initial safety checks shall include:
 - i. Ensure that capacitors are discharged—this shall be done in a safe manner to avoid the possibility of sparking.
 - ii. Ensure that no live electrical components and wiring are exposed while charging, recovering, or purging the system.
 - iii. Ensure that there is continuity of earth bonding.
- Do not apply any permanent inductive or capacitance loads to the circuit without ensuring that this will not exceed the permissible voltage and current permitted for the equipment in use.
- LOCK OUT / TAG OUT — To avoid serious injury or death from electrical shock, always disconnect the electrical power at the main disconnect when servicing or replacing any electrical component. This includes, but is not limited to, such items as doors, lights, fans, heaters, and thermostats.
- Check that cabling will not be subject to wear, corrosion, excessive pressure, vibration, sharp edges, or any other adverse environmental effects. The check shall also take into account the effects of aging or continual vibration from sources such as compressors or fans.
- Refrigerating pipe or components are installed in a position where they are unlikely to be exposed to any substance which may corrode refrigerant containing components, unless the components are constructed of materials which are inherently resistant to being corroded or are suitably protected against being so corroded.
- To reduce the risk of fire, electrical shock or injury when cleaning this merchandiser:
 - Unplug the merchandiser before cleaning.
 - Keep all liquids away from electrical and electronic components.

Excel Open Island and Wall

Maintenance and Service

Care and Cleaning

Long life and satisfactory performance of any equipment is dependent upon the care it receives. To ensure long life, proper sanitation and minimum maintenance costs, this equipment should be thoroughly cleaned, all debris removed and the interiors washed down. Cleaning often will control or eliminate odor buildup. Frequency of cleaning is dependent on usage and local health requirements. All case cleaning and maintenance procedures should be performed with the power disconnected at the breaker. Failure to adhere to these instructions can lead to damage to the unit and creates the risk of flammability or electrical shock.

Fan Plenum

To facilitate cleaning, the fan plenum is hinged and also fastened with screws at each end. After cleaning be sure the plenum is properly lowered into position and that screws are reinstalled or product loss will result due to improper refrigeration. Do not unplug the fan motor harness. The fan motor harness should not be disconnected or reconnected to perform cleaning. This connection should only be disconnected or reconnected by a qualified contractor and only in the event of fan motor replacement.

Interior Surfaces

The interior surfaces may be cleaned with most domestic detergents, ammonia based cleaners and sanitizing solutions with no harm to the surface.

Exterior Surfaces

The exterior surfaces should be cleaned with a mild detergent and warm water to protect and maintain their attractive finish. Never use abrasive cleansers or scouring pads.

Do Not Use:

- Abrasive cleansers and scouring pads, as these will mar the finish.
- Coarse paper towels on coated glass.
- Ammonia-based cleaners on acrylic parts.
- Solvent, oil or acidic based cleaners on any interior surfaces.

Do:

- Remove the product and all loose debris to avoid clogging the waste outlet.
- Store product in a refrigerated area such as a freezer. Remove only as much product as can be taken to the freezer in a timely manner.
- First turn off refrigeration, then disconnect electrical power.
- Thoroughly clean all surfaces with soap and hot water.
- Do not use steam or high water pressure hoses to wash the interior. These will destroy the merchandisers' sealing causing leaks and poor performance.
- Take care to minimize direct contact between fan motors and cleaning or rinse water.
- Rinse with hot water, but do not flood.
- Never introduce water faster than the waste outlet can remove it.
- Allow merchandisers to dry before resuming operation.
- After cleaning is completed, turn on power and refrigerant to the merchandiser.
- Verify that merchandiser is working properly.

Excel Open Island and Wall

Maintenance and Service

Recommended Cleaning Instructions

The directions below are recommended cleaning instructions for Impact Reach-in cases and should not be used as a substitute for the store's regular maintenance schedule. Follow all local and national health codes. Cleanliness of the case encourages long-lasting life of the equipment. This guide lists some of the key areas of the cases that require cleaning to help maintain the overall appearance and performance of the equipment and keep it free of debris. The cases may need additional cleaning, especially in high traffic areas, dusty areas and during unusually extended periods of use of the equipment.

Weekly or Monthly

1. Remove the product and store it in a separate case or a suitable walk-in cooler.
2. Take out the wire racks and bottom pans, and clean them in warm, soapy water. Rinse them thoroughly and set them aside.
3. Turn off the power to the case at the breaker.
4. Remove all loose debris and food particles that could clog the drain. Check the drain to ensure it is not obstructed. Avoid forcing items down the drain
5. Clean all surfaces by spraying them with warm water and mild detergent. Use a brush or cleaning pad if necessary to help remove dirt.
6. Rinse all surfaces with clean water, then spray them with a sanitizer. After allowing the sanitizer to sit for a moment, rinse it off with clean water using a hose. Let the surfaces air dry, as wiping them could undermine the sanitization process.
7. Carefully replace all internal parts, ensuring they are seated properly for optimal case performance.
8. Turn the power to the fans back on at the breaker.
9. Replace the product.

Quarterly or Semiannually

1. Remove product; store it in another case or suitable walk-in cooler.
2. Take out the wire racks and bottom pans, and clean them in warm, soapy water. Rinse them thoroughly and set them aside.
3. Turn off the power to the case at the breaker.
4. Remove all loose debris and food particles that may clog drain. Check drain to make sure it is not clogged. Do not force items down drain
5. Clean all surfaces by spraying down water (preferably warm) and mild detergent. Use a brush or cleaner pad if necessary to aid in penetrating dirt.
6. Clean the newly exposed surfaces and the coil by spraying down with water (preferably warm) and a mild detergent solution.
7. Rinse the newly exposed surfaces and the coil with water then spray with a sanitizer. Allow surfaces to air-dry, since wiping would defeat the purpose of sanitizing.
8. Rinse all surfaces with water, then spray with a sanitizer. Allow surfaces to air-dry since wiping would defeat the purpose of sanitizing.
9. Replace all remaining internal parts carefully so that they seat properly. This is necessary for proper case operation.
10. Turn the power to the fans back on at the breaker.
11. Replace the product.

Excel Open Island and Wall

Maintenance and Service

Cleaning Airflow Louvers

Louvers should be cleaned at least every six months. Dirty louvers adversely affect model performance.

1. Remove screws and louver retainer.
2. Lift the louver, then rotate the bottom out.
3. Clean the louvers with soap and water. Dry thoroughly.
4. When completely dry, re-install louvers and retainer.

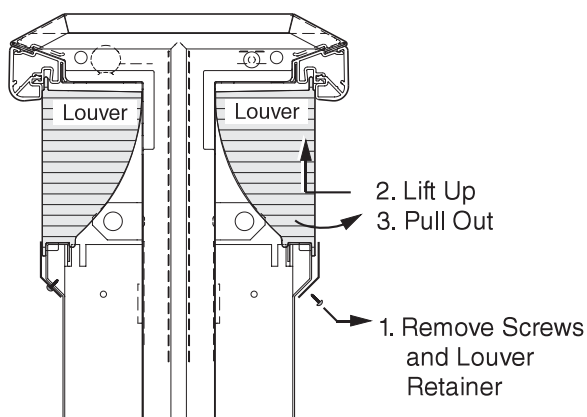

Cleaning Wire Racks, Pans, and Interior Panels

With the louver assembly removed, all interior wire racks, supports and drip pans may be lifted out without tools. Refer to illustration on next page.

Begin by lifting out the display racks and front and back display rack supports. Remove display pans, beginning from the left. Pans overlap when properly installed.

Carefully lift up glass package guard to clear clips attached to front panel. It is not necessary to remove clips from panel. Lift out return air grilles. The glass may be cleaned with most domestic detergents, ammonia-based cleaners and sanitizing solutions with no harm to the surface. Never use abrasive cleansers or scouring pads.

Front and rear internal panels rest on interior panel supports. Panels and supports lift out.

Reinstall in reverse order.

Cleaning Stainless Steel Rails



Use non-abrasive cleaning materials, and always polish with grain of the steel. Use warm water or add a mild detergent to the water and apply with a cloth. Always wipe rails dry after wetting.

Use alkaline chlorinated or non-chlorine containing cleaners such as window cleaners and mild detergents. Do not use cleaners containing salts as this may cause pitting and rusting of the stainless steel finish. Do not use bleach.

Clean frequently to avoid build-up of hard, stubborn stains. A stainless steel cleaning solution may be used periodically to minimize scratching and remove stains.

Rinse and wipe dry immediately after cleaning. Never use hydrochloric acid (muriatic acid) on stainless steel.

Excel Open Island and Wall

Maintenance and Service

FWG Shown — Other
Low Temperature Excel
Model Parts are Similar

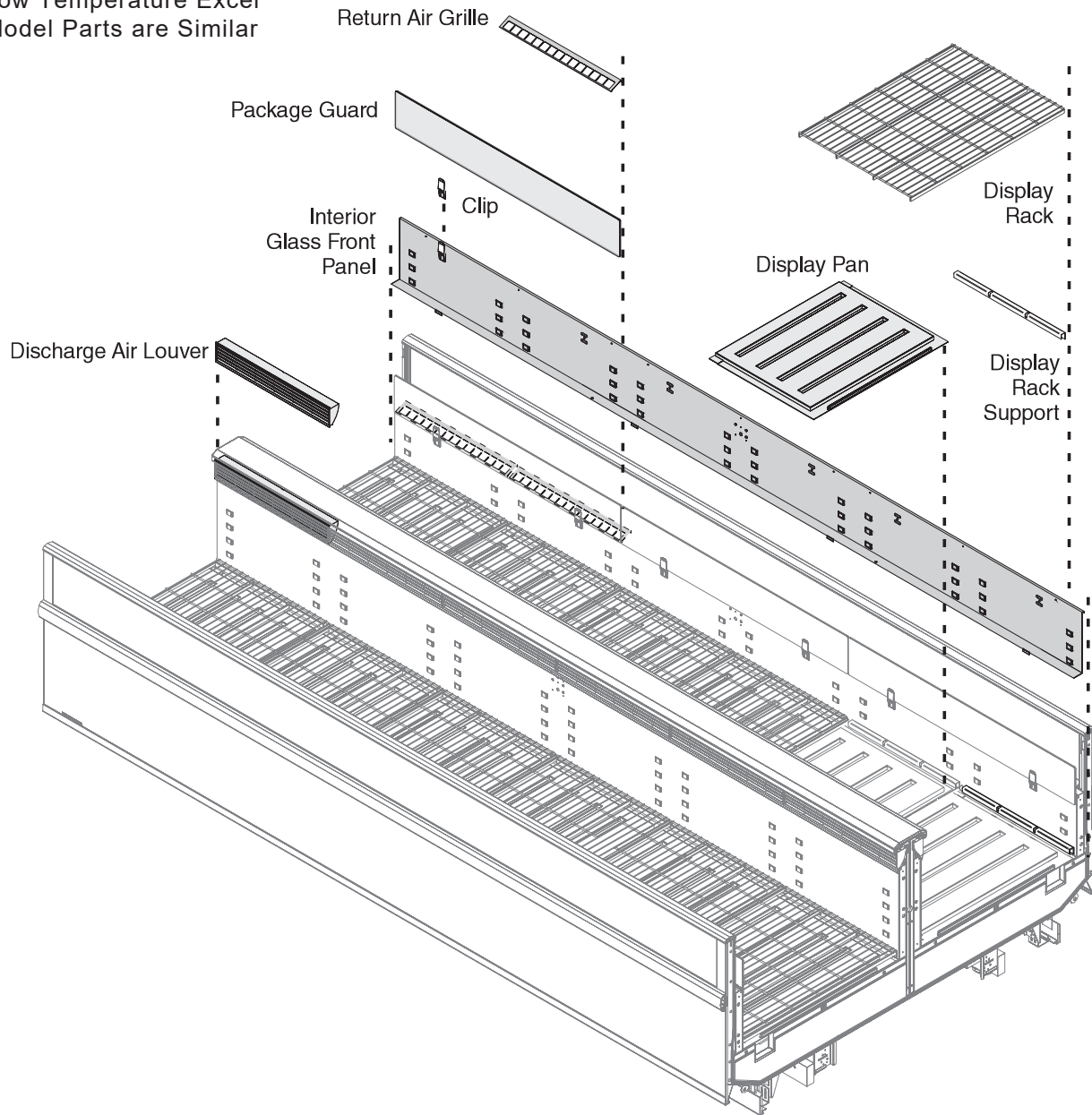

Cleaning Coils

Never use sharp objects around coils. Use a soft brush or vacuum brush to clean debris from coils. Do not puncture coils. Do not bend fins. Contact an authorized service technician if a coil is punctured, cracked, or otherwise damaged. Do NOT use chlorine or ammonia-based cleaners to clean aluminum coils.

Ice in or on the coil indicates the refrigeration and defrost cycle is not operating properly. Contact an authorized service technician to determine the cause of icing, and to make adjustments as necessary. To maintain product integrity, move all product to a cooler until the unit has returned to normal operating temperatures.

Excel Open Island and Wall

Maintenance and Service

Removing Rear Flue Glass for Cleaning (FIG & FNG)

1. Remove louvers, then remove the discharge deflector brackets. The flue glass (with retainer) may then be lifted out.
2. Remove interior panels to facilitate thorough cleaning.
3. Reinstall in reverse order.

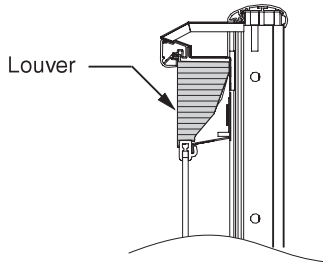

Removing Scratches from Bumper

Most scratches and dings can be removed using the following procedure.

1. Use steel wool to smooth out the surface area of the bumper or top rail.
2. Clean area.
3. Apply vinyl or car wax and polish surface for a smooth glossy finish.

Cleaning Under Merchandisers

Remove splashguards not sealed to floor. Use a vacuum with a long wand attachment to remove accumulated dust and debris from under the merchandiser.

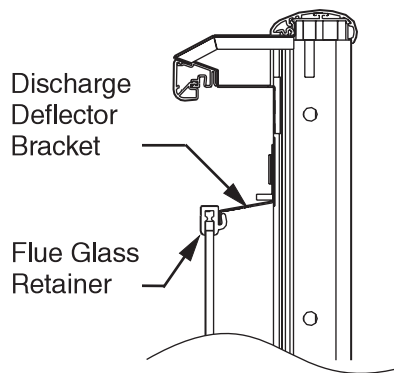
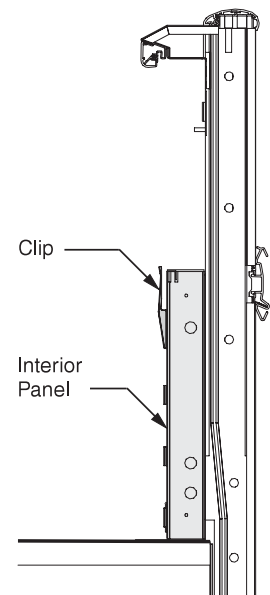
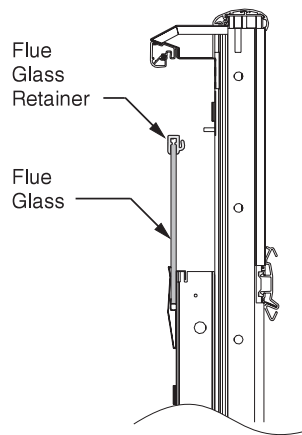
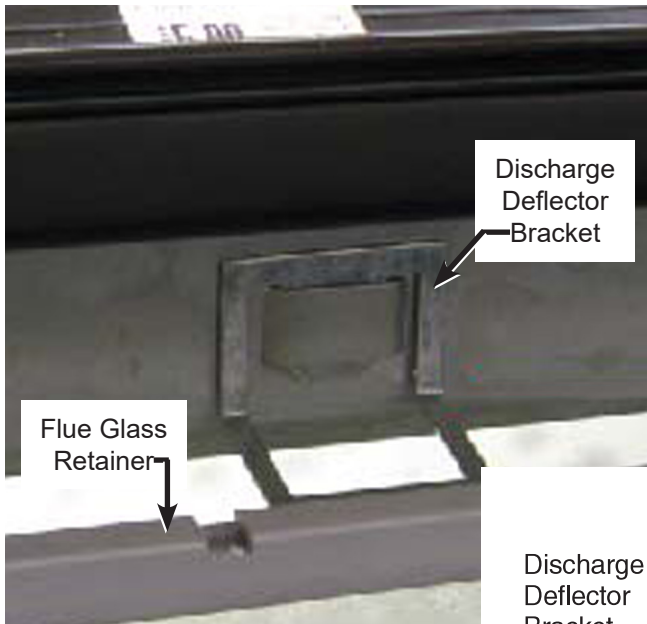

Excel Open Island and Wall

Maintenance and Service

Troubleshooting

This guide is designed to help identify, diagnose and resolve common issues.

Issue	Possible Cause(s)	Potential Solution	
case temperature is too warm	Splashguard fan harness is unplugged (A2L cases only).	Ensure splashguard fan harness is firmly connected. Safety shut-off valve will not open unless splashguard fan harness is connected.	
	ambient conditions may be affecting the case operation.	ensure case is not positioned near sources of air disturbances such as open doors, windows, electric fans, or air conditioning vents; case must be located at least 15 feet away from any doors or windows; check ambient design conditions on the serial plate	
	discharge air temp is out of specified range	check evaporator fan operation	check electrical connections and input voltage
		fans are installed backwards; check airflow direction	
		make sure fan blades have correct pitch and are per specification	
		check to see that fan plenum is installed correctly with no air gaps	
		check suction pressure and ensure that it meets factory specifications	
case is in defrost; check defrost settings see technical datasheet			
product is outside of the load limit area, blocking airflow	redistribute product so it does not exceed load limit there is a sticker on the inside of the case indicating the maximum load limit		
coil is freezing over. condensing coil or evaporator coil is clogged or dirty	return air is blocked, make sure debris is not blocking the intake section		
	coil close-offs are not installed. Inspect coil to make sure these parts are on the case		
	clean coil		
case temperature is too cold	t-stat temp is set too low	check settings; see technical specifications on the datasheet	
	ambient conditions may be affecting the case operation	ensure case is not positioned near sources of air disturbances such as open doors, windows, electric fans, or air conditioning vents; case must be located at least 15 feet away from any doors or windows; check ambient design conditions on the serial plate	
frost or ice on evaporator coil	evaporator fans are not functioning	check electrical connections	
	defrost clock is not functioning	case should be serviced by a qualified service technician	
	coil is freezing over	return air is blocked, make sure debris is not blocking the intake section	
coil close-offs are not installed. Inspect coil to make sure these parts are on the case			
coil freezing	lack of airflow over the coil	check for proper clearance and installation location	
		coil is clogged or dirty - clean coils	
		check fans for cleanliness and proper function	
	low refrigerant charge/pressure	check system charge/pressure	
		check system piping to ensure there are no problematic restrictions or design features	
check for abnormal pressure drops at metering devices and valves			
water has pooled under case; case not draining properly	case drain is clogged.	clear drain.	
	PVC drains under case may have a leak.	repair as needed.	
	drain screen or p-trap clogged	clear debris	
lights do not come on (if case is equipped with lighting)	LED driver / light socket wiring	check electrical connections	
	LED driver needs to be replaced	case should be serviced by a qualified technician	
	LED fixture socket / connection	case should be serviced by a qualified technician	
	LED fixture needs to be replaced	lighting should only be replaced with like parts contact your Hussmann representative	
	light switch needs to be replaced	case should be serviced by a qualified service technician	

Excel Open Island and Wall

Maintenance and Service

Refrigerant Removal, Evacuation, and Recovery

WARNING: Always use a pressure regulator when operating nitrogen tanks.

WARNING: Never trap liquid refrigerant between closed valves as this could cause a hydraulic explosion.

When breaking into the refrigerant circuit to make repairs—or for any other purpose—conventional procedures shall be used. However, for flammable refrigerants it is important that best practice be followed, since flammability is a consideration. The following procedure shall be adhered to:

- a. Safely remove refrigerant following local and national regulations
- b. Purge the circuit with inert gas
- c. Evacuate
- d. Purge with inert gas
- e. Open the circuit by cutting or brazing

The refrigerant charge shall be recovered into the correct recovery cylinders if venting is not allowed by local and national codes. The system shall be purged with oxygen-free nitrogen to render the appliance safe for flammable refrigerants. This process might need to be repeated several times. Compressed air or oxygen shall not be used for purging refrigerant systems.

Refrigerants purging shall be achieved by breaking the vacuum in the system with oxygen-free nitrogen and continuing to fill until the working pressure is achieved, then venting to atmosphere, and finally pulling down to a vacuum. This process shall be repeated until no refrigerant is within the system. When the final oxygen-free nitrogen charge is used, the system shall be vented down to atmospheric pressure to enable work to take place.

Nitrogen and moisture will remain in the system unless proper evacuation procedures are followed. Nitrogen left in the system may cause head pressure problems. Moisture causes EEV ice blockage, wax build up, acid oil, and sludge formation.

Do not simply purge the system. This procedure is expensive, harmful to the environment, and may leave moisture and nitrogen behind.

Do not run the compressors to evacuate. This procedure introduces moisture into the compressor's crankcase oil and does not produce adequate vacuum to remove moisture from the rest of the system at normal temperatures.

Ensure that the outlet for the vacuum pump is not close to any potential ignition sources and that ventilation is available.

Excel Open Island and Wall

Maintenance and Service

Recovery Procedure

When removing refrigerant from a system, either for servicing or decommissioning, it is recommended good practice that all refrigerants are removed safely. When transferring refrigerant into cylinders, ensure that only appropriate refrigerant recovery cylinders are employed. Ensure that the correct number of cylinders for holding the total system charge is available.

All cylinders to be used are designated for the recovered refrigerant and labeled for that refrigerant (i.e., special cylinders for the recovery of refrigerant). Cylinders shall be complete with pressure-relief valve and associated shut-off valves in good working order. Empty recovery cylinders are evacuated and, if possible, cooled before recovery occurs.

The recovery equipment shall be in good working order with a set of instructions concerning the equipment that is at hand and shall be suitable for the recovery of all appropriate refrigerants including, when applicable, FLAMMABLE REFRIGERANTS. In addition, a set of calibrated weighing scales shall be available and in good working order. Hoses shall be complete with leak-free disconnect couplings and in good condition. Before using the recovery machine, check that it is in satisfactory working order, has been properly maintained and that any associated electrical components are sealed to prevent ignition in the event of a refrigerant release. Consult manufacturer if in doubt.

The recovered refrigerant shall be returned to the refrigerant supplier in the correct recovery cylinder, and the relevant waste transfer note arranged. Do not mix refrigerants in recovery units and especially not in cylinders.

If compressors or compressor oils are to be removed, ensure that they have been evacuated to an acceptable level to make certain that FLAMMABLE REFRIGERANT does not remain within the lubricant. The evacuation process shall be carried out prior to returning the compressor to the supplier. Only electric heating to the compressor body shall be employed to accelerate this process.

When oil is drained from a system, it shall be carried out safely.

Leak Detection (all refrigerants)

Under no circumstances shall potential sources of ignition be used in the searching for or detection of refrigerant leaks. Do not unplug any device if a leak is detected or suspected. A halide torch (or any other detector using a naked flame) shall not be used. The following leak detection methods are deemed acceptable for all refrigerant systems:

- Electronic leak detectors may be used to detect refrigerant leaks but, in the case of FLAMMABLE REFRIGERANTS, the sensitivity might not be adequate, or might need recalibration. (Detection equipment shall be calibrated in a refrigerant-free area.) Ensure that the detector is not a potential source of ignition and is suitable for the refrigerant used. Leak detection equipment shall be set at a percentage of the LFL of the refrigerant and shall be calibrated to the refrigerant employed, and the appropriate percentage of gas (25% maximum) is confirmed.
- Leak detection fluids are also suitable for use with most refrigerants but the use of detergents containing chlorine shall be avoided as the chlorine can react with the refrigerant and corrode the copper pipe-work.

Note: Examples of leak detection fluids are bubble method and fluorescent method agents.

If a leakage of refrigerant is found which requires brazing, all of the refrigerant shall be recovered from the system, or isolated (by means of shut off valves) in a part of the system remote from the leak. Removal of refrigerant shall be according to the Refrigerant Recovery section provided.

Excel Open Island and Wall

Maintenance and Service

A2L Leak Detection Sensor Service and Mitigation

WARNING

- Do not drop or apply direct impact to the sensor.
- Do not apply any sharp-pointed items to the membrane filter. A broken filter will damage the water protection feature and accuracy in detection.
- Do not cover the membrane filter.
- Do not apply any air or liquid flow with high pressure.
- Do not install the sensor on curved surfaces unless the sensor remains securely fixed without bending.
- The sensor should NOT be mounted with the membrane and sensor exposed to protect the sensor from contamination and moisture.
- Do not expose the detector to temperatures above 248° F (120° C); the plastic housing may become deformed.
- Do not spray any cleaning agents on the sensor.
- Do not clean the device with corrosive chemical products, solvents, or abrasive detergents.
- Clean the enclosure only with a damp cloth. Electrostatic spark risk.
- If a leak is suspected, all naked flames shall be removed/extinguished.
- The use of silicon sealant can inhibit the effectiveness of some types of leak detection equipment. Intrinsically safe components do not have to be isolated prior to working on them.
- **IMPORTANT—Electrostatic Spark Risk—**Disconnect all electrical connections and pass a damp cloth on the detector enclosure before performing any maintenance.

It is recommended to always have spare sensors on-hand to prevent system from being down for an extended period in the event of a sensor expiration or failure.

A2L-equipped equipment comes with pre-installed Danfoss sensors. If your equipment uses A2L and has a different sensor or no sensor present as indicated, contact Hussmann immediately before proceeding with service or maintenance.

It is important not to relocate, remove, or disable any factory leak detection devices. These components must be replaced with the same exact part by authorized service personnel only.

Excel Open Island and Wall

Maintenance and Service

Sensor Parts List

Danfoss System	
Part Description	Part Number
R-454A sensor	3216202
R-454C sensor	3216203
12-inch (305 mm) sensor harness	3216204
40-inch (1 m) sensor harness	3216206
60-inch (1.5 m) sensor harness	3216207
100-inch (2.5 m) sensor harness	3216208
240-inch (6.1 m) sensor harness	3216209

Sensor Specifications and Wiring

Specification	Value
Electrical Voltage	24 VAC +/- 10% and 24 VDC (8–32 VDC)
Compatible Refrigerant	R-454A or R-454C (as specified)

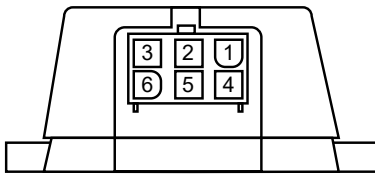

Pin Number	Function	Harness Wire Color (at sensor connection)
Pin 1	Supply Voltage	red
Pin 2	Earth/Ground	black
Pin 3	Mod A (Data +) (not used)	white
Pin 4	Mod B (Data -) (not used)	blue
Pin 5	Input Relay	yellow
Pin 6	Normally Open Contacts Output	orange

Relay Operation





- Relay is energized on power up when not in alarm state
- Relay is de-energized in alarm or no power state

Excel Open Island and Wall

Maintenance and Service

Sensor Mitigation and Alarms

When the sensor is powered on, an LED positioned on the back of the sensor near the sensor membrane indicates its status. When the sensor is mounted, the LED backlights the sensor and can be seen as a reflection on the mounting surface.

	Solid green	-Sensor power-up and self-test
	Blinking green	-Normal operation (heartbeat)
	Solid red	-Alarm state – gas detected
	Blinking red	-Sensor fault

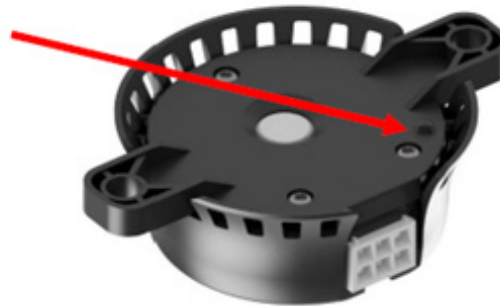

When the sensor detects a gas reading at or above the alarm threshold, the relay de-energizes, causing the relay contacts to open during the alarm. Additionally, the alarm flag is set in the alarm status register.

To reset the alarm, the sensor reading must drop at least 2.5% below the alarm threshold. Once this happens follow instructions in the 'Sensor Reset Instructions' section below. After completing this, the relay re-energizes and the sensor returns to normal operation. The alarm flag is also cleared by these actions. After the alarm is reset, the relay remains open for five seconds before resuming normal operation.

Note: If not manually reset, the sensor will not automatically reset for approximately 24 days.

Self-diagnostics are performed when the sensor is first powered on. If a fault is detected the sensor LED will begin to blink red approximately 5 seconds after being powered on. These tests ensure the integrity of the memory, embedded program, and power supply.

The sensor continuously performs diagnostics to monitor its integrity, checking for issues such as shorts, open circuits, out-of-range values, and communication errors, as well as the integrity of the on-board memory, programming, oscillator, and voltage levels.

Sensor Cleaning

- Before beginning any cleaning activity, turn off the unit or isolate supply power to the sensor to avoid any electrical short or induced alarm.
- In order to clean the sensor, use a dry microfiber cloth only to lightly wipe off the enclosure.
- Do not apply pressure on the sensor opening or membrane
- Do not insert anything into the ports or touch the membrane directly
- Do not use alcohol or isopropyl alcohol, acetone, solvents, spray cleaners (e.g., degreasers, window cleaner, etc.), compressed air, vacuums, brushes, or cotton swabs when cleaning the sensor to avoid damage to the membrane or damage to the sensor

Excel Open Island and Wall

Maintenance and Service

Sensor Position

F-Series case A2L refrigerant leak sensor(s) are mounted inside the case's A2L valve compartment, right next to the refrigerant piping connection and the A2L shut-off valve. Each valve assembly section contains a sensor.

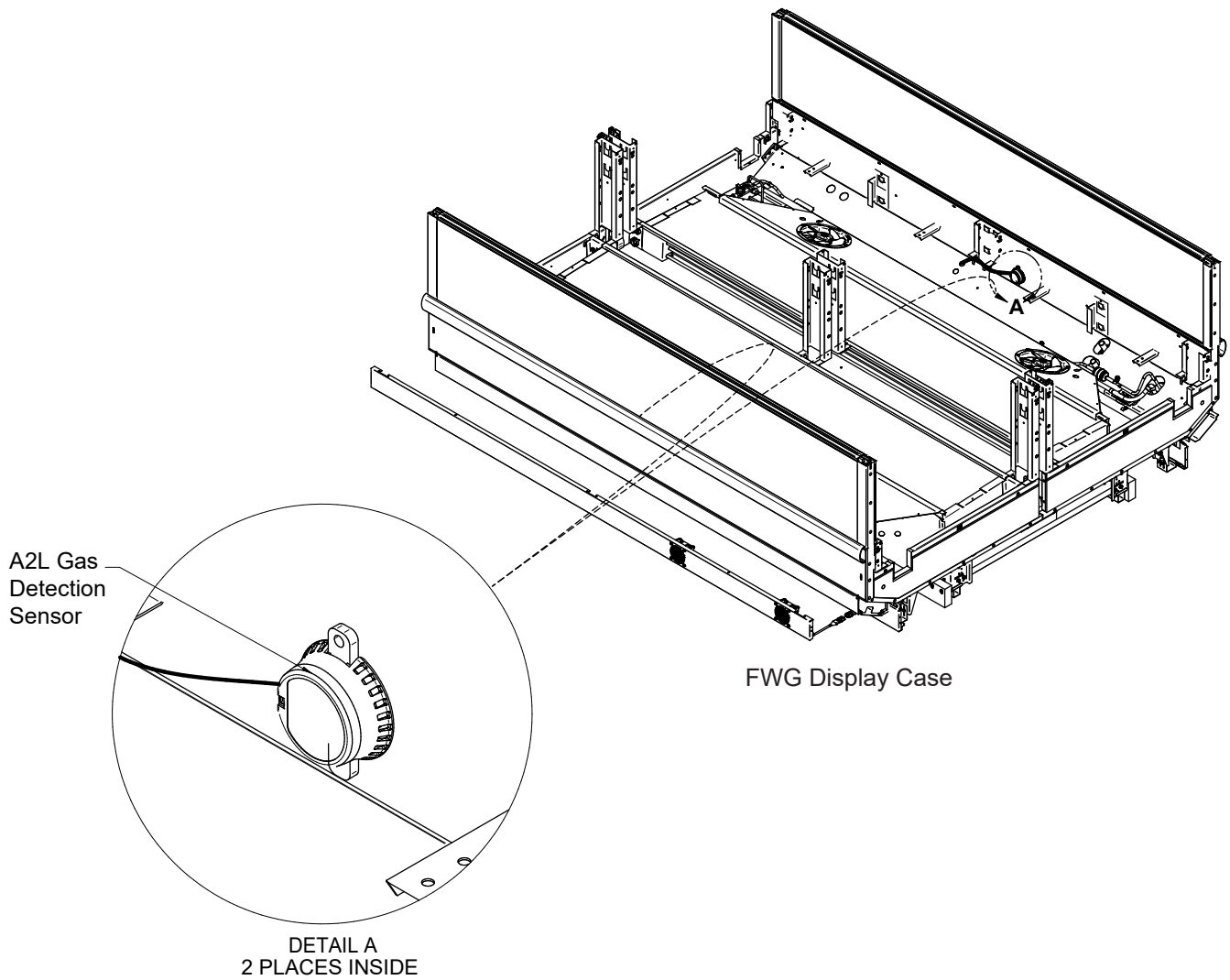

Excel Open Island and Wall Maintenance and Service

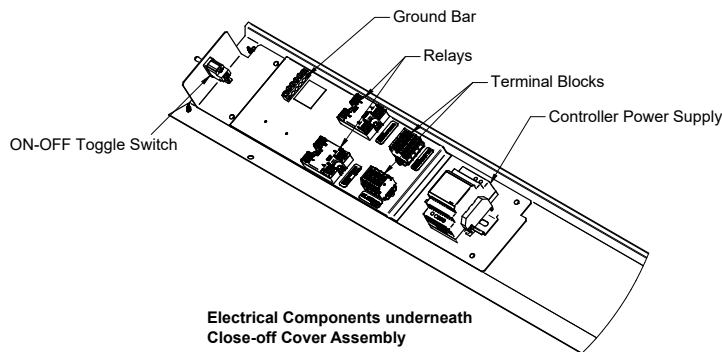
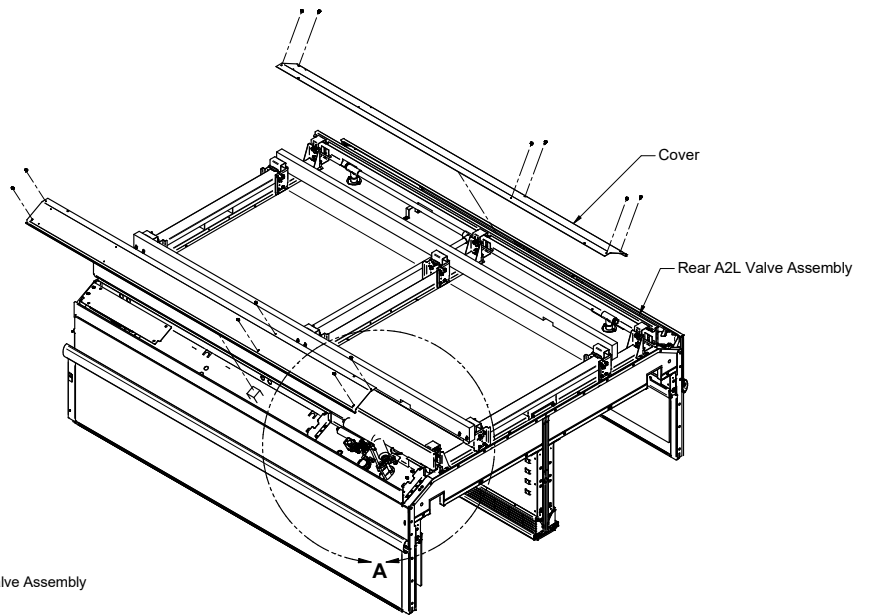
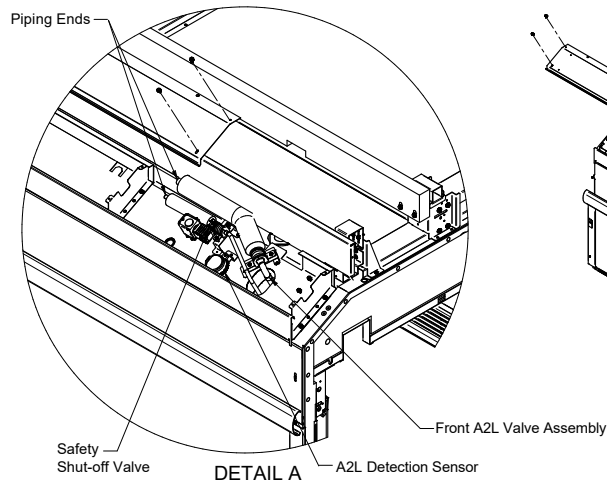

FWG model shown. Other F-Series models have similar A2L leak sensor locations.

Note: End cases have only one A2L compartment (on the front side).

Sensor System Check

These steps should be used to verify proper operation at system startup and periodically (at least annually) during normal maintenance.

Warning: The lighter used for testing should never be struck or lit to cause a spark or flame at any point, it is only being used for the gas it emits.

1. Power on sensor 1 and let it complete initialization routine.
2. Green light should be active (normal status/blinking).
3. Expose sensor 1 to mixture by holding the button on a lighter without touching the striker (it should trigger in less than 60 seconds). The end of the lighter the gas comes out will need to be placed near the base of the sensor where it mounts to the unit.
4. Verify that sensor 1 triggers an alarm (open/de-energized inside relay) and switches to red light.
5. Verify that the liquid shut-off solenoid(s) are de-energized and closed.
6. Verify that ventilation fans are activated (if applicable).
7. Wait five minutes, then manually reset the sensor using the procedure in the following section and verify it is in normal state.
8. If the case has multiple sensors, repeat steps 3-7 for each remaining sensor.

If needed, the system (external to the sensor) can also be tested independently by opening the circuits that go to pin #5 and #6 wherever possible in the wiring harness without cutting. This would simulate the sensor detecting a leak and allow the shut-off valve(s) and ventilation (if applicable) function to be tested. If this method is used, ensure any disconnected wiring is reconnected and perform the reset procedure (in the following section) before finishing service/inspection.

Excel Open Island and Wall

Maintenance and Service

Sensor Reset Instructions (after leak event or test)

1. Verify Safe Conditions
 - Confirm that there is no active refrigerant leak and that the environment is safe to proceed.
 - Ensure all personnel involved are properly trained and authorized to perform reset operations.
2. Access Control Panel
 - Open the electrical control panel where the power for leak detection system is installed.
3. Locate the Toggle Switch
 - Inside the control panel, identify the designated switch assigned for the leak sensor power control.
4. Perform Power Cycle Reset
 - Flip the toggle switch to the OFF position to remove power from the leak detection sensor.
 - Wait approximately 5–10 seconds to allow the sensor and associated safety circuits to fully de-energize.
 - Flip the toggle switch back to the ON position to reapply power.
5. Confirm System Reset:
 - Verify that the sensor alarm has been cleared.
 - Confirm that all safety valves have returned to their normal operating state.
 - Observe the system for any abnormal indicators or alarm recurrence.

Sensor Replacement

Replacement sensors should be of the same type and mounted in the original locations and orientation only.

- Max torque for screws is 6.2 lb-in (0.7 N-m)
- Mounting holes are sized for #10– #12 self-tapping sheet metal screws
- Recommended installation position is with connector down. When this is not possible, rotation up to 90 degrees left or right is acceptable.

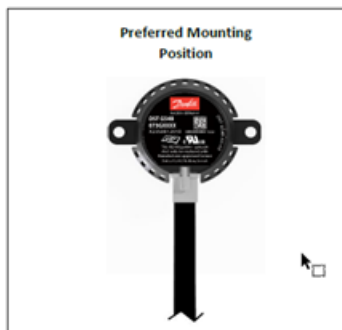

Mount Sensor with cable facing downward if possible. This is to minimize Water ingress from the cable and connector.



Alternative mounting if downward is not possible. Cable can exit 90 degrees from right or left side. Any angle from downward 0 degrees up to 90 degrees can be used.



Replacement Steps

1. Before replacing sensor, first ensure no refrigerant leak is detected and then that the power is off. Also, ensure the exact same sensor part number is being used as a replacement by comparing the two sensors.
2. Remove two mounting screws from sensor.
3. Disconnect wires from relay and controller.
4. Attach new sensor in the same orientation and position with the previously removed screws.
5. Connect wiring to relay and controller per the wiring diagram.
6. Reconnect power. The refrigerant sensor should now run through the initialization process.

Excel Open Island and Wall

Maintenance and Service

Component Replacement

Replacing Fan Motors and Blades



Always disconnect the electrical power at the main disconnect when servicing or replacing any electrical component. This includes, but is not limited to, such items as doors, lights, fans, heaters, and thermostats.

The fan motor harness plug must be properly secured. This connection should only be disconnected or connected by a qualified contractor and only in the event of fan motor replacement.

See cross section in data sheet for location of evaporator fans. Should it ever be necessary to service or replace the fan motors or blades be certain that the fan blades are re-installed correctly.

For access to fans:

1. Turn off power at the breaker.
2. Remove wire racks and display pans from the compartment being serviced.
3. Disconnect fan from wiring harness.
4. Remove fan blade.
5. Remove screws holding fan motor/bracket assembly to plenum and remove assembly.
6. Replace fan motor/bracket assembly and reinstall screws.
7. Reinstall fan blade.
8. Reconnect fan to wiring harness.
9. Turn on power.
10. Verify that motor is working and blade is turning in the correct direction.
11. Close large air gaps under fan plenum. Warmer air moving into refrigerated air reduces effective cooling. If the plenum does not rest against the case bottom without gaps, apply foam tape to the bottom of the fan plenum to reduce improper air movement, however defrost water should not be blocked by fan plenum. Do NOT seal fan plenum so that water can not drain.
12. Replace display pans.
13. Bring merchandiser to operating temperature before restocking.

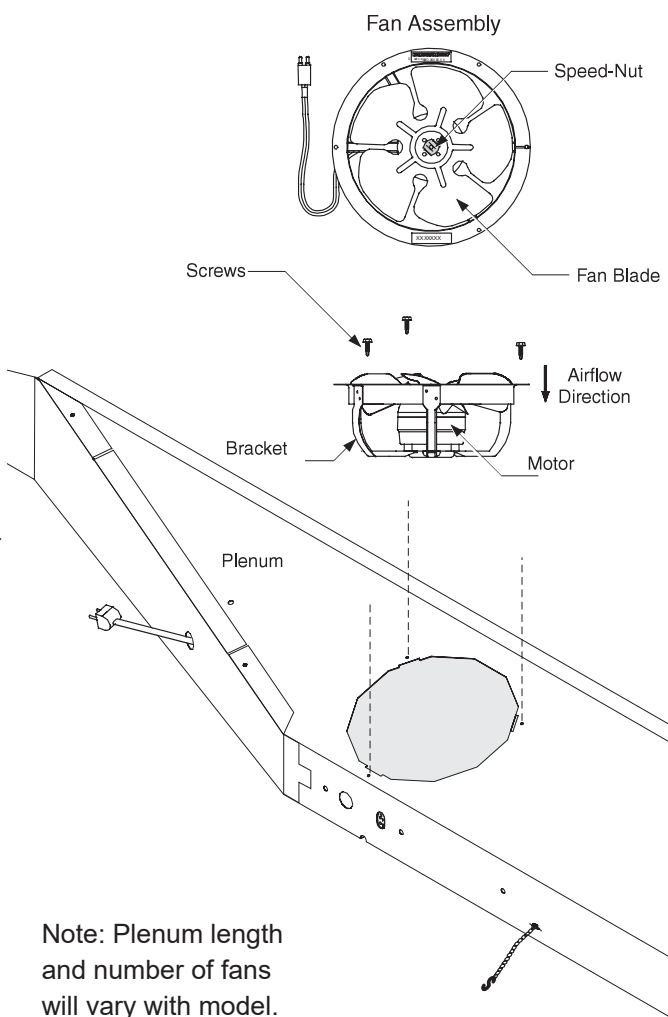

Note: Plenum length and number of fans will vary with model.

Excel Open Island and Wall

Maintenance and Service

Replacing Electric Defrost Heater

These heaters are installed at the front of the coils. They may be accessed by lifting the fan plenums. To replace:

1. Turn off power to merchandiser.
2. Remove wire racks and display pans from the compartment being serviced.
3. Hinge up and fasten the fan plenum to the interior back panel with chain and hook provided.
4. Unplug the heater from the heater harness.
5. Remove the heater from the face of the coil by rotating the support tab far enough to free the heater element.
6. Position the new heater and rotate the support tab back to the original position.
7. Reconnect heater to wiring harness.
8. Lower the fan plenum to operating position.
9. Reconnect power.
10. Verify heater is working properly.
11. Replace display pans and wire racks. Bring case to operating temperature before restocking.

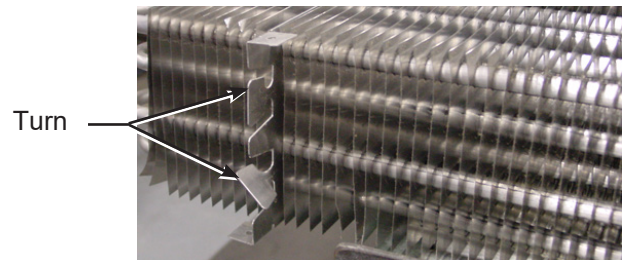
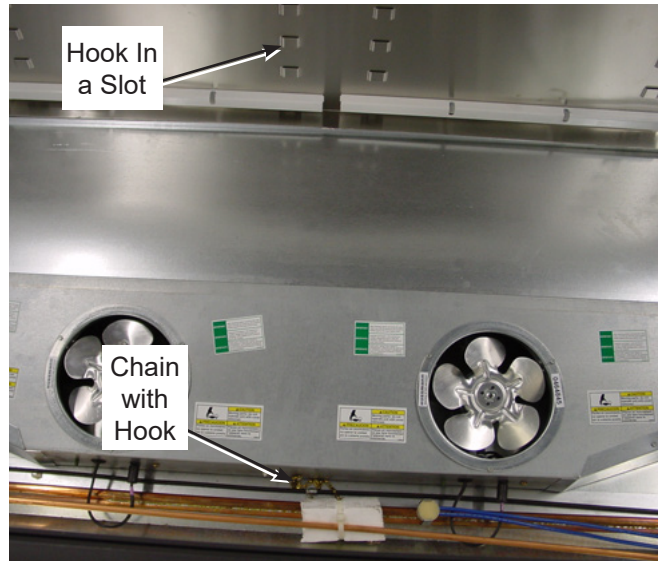
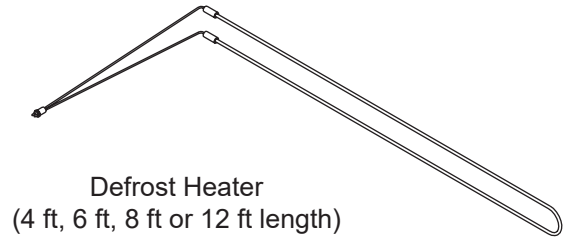

⚠ WARNING

— LOCK OUT / TAG OUT —

- » To avoid serious injury or death from electrical shock, always disconnect the electrical power at the breaker when servicing or replacing any electrical component. This includes, but is not limited to, such items as doors, lights, fans, heaters, and thermostats.

Excel Open Island and Wall Maintenance and Service

Replacing Hand Rail Heater (Solid Fronts)

To replace the heater:

1. Turn OFF the power to the merchandiser.
2. Remove return grilles, package guard and interior panel as needed from the compartment being serviced.
3. Remove screw and corner cap.
4. Remove screws, grounding wire harness and corner cap bracket.
5. Remove hand rails, hand rail retainers and heater from hand rail retainers.
6. Remove wireway cover.

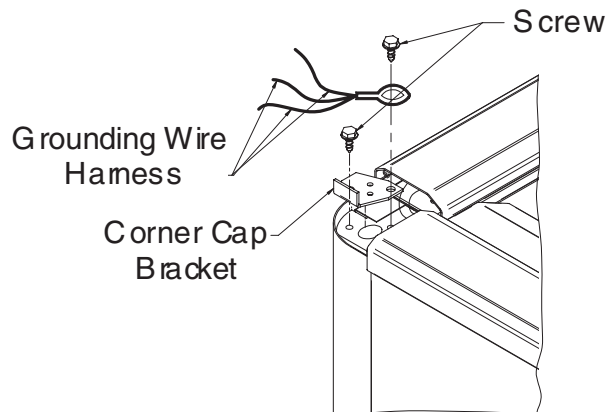
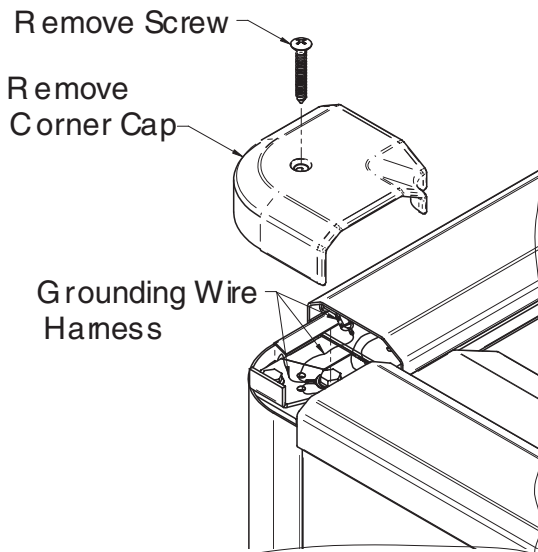
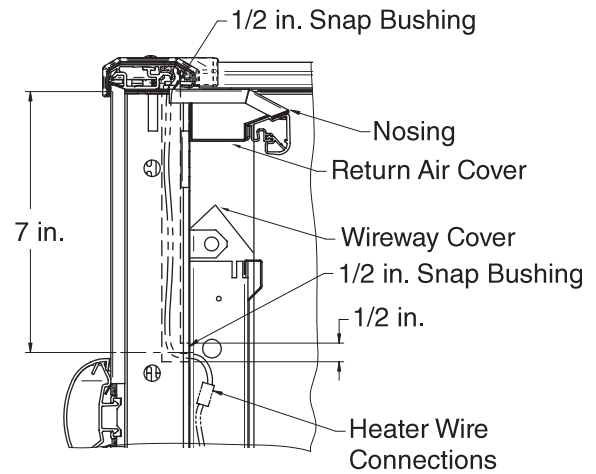

⚠ WARNING

— LOCK OUT / TAG OUT —

» To avoid serious injury or death from electrical shock, always disconnect the electrical power at the breaker when servicing or replacing any electrical component. This includes, but is not limited to, such items as doors, lights, fans, heaters, and thermostats.

Excel Open Island and Wall

Maintenance and Service

7. Disconnect, and remove hand rail heater from wireway.
8. Replace heater connections and re-route new heater onto hand rail retainers.
9. Clean rail surfaces thoroughly, then install new hand rail heater.
10. Reinstall parts in reverse order. Any damaged parts must be replaced.

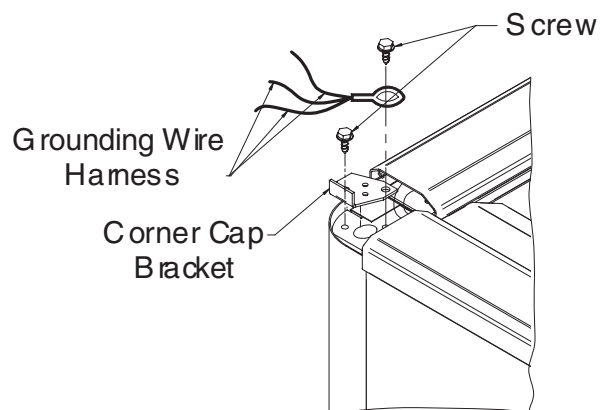
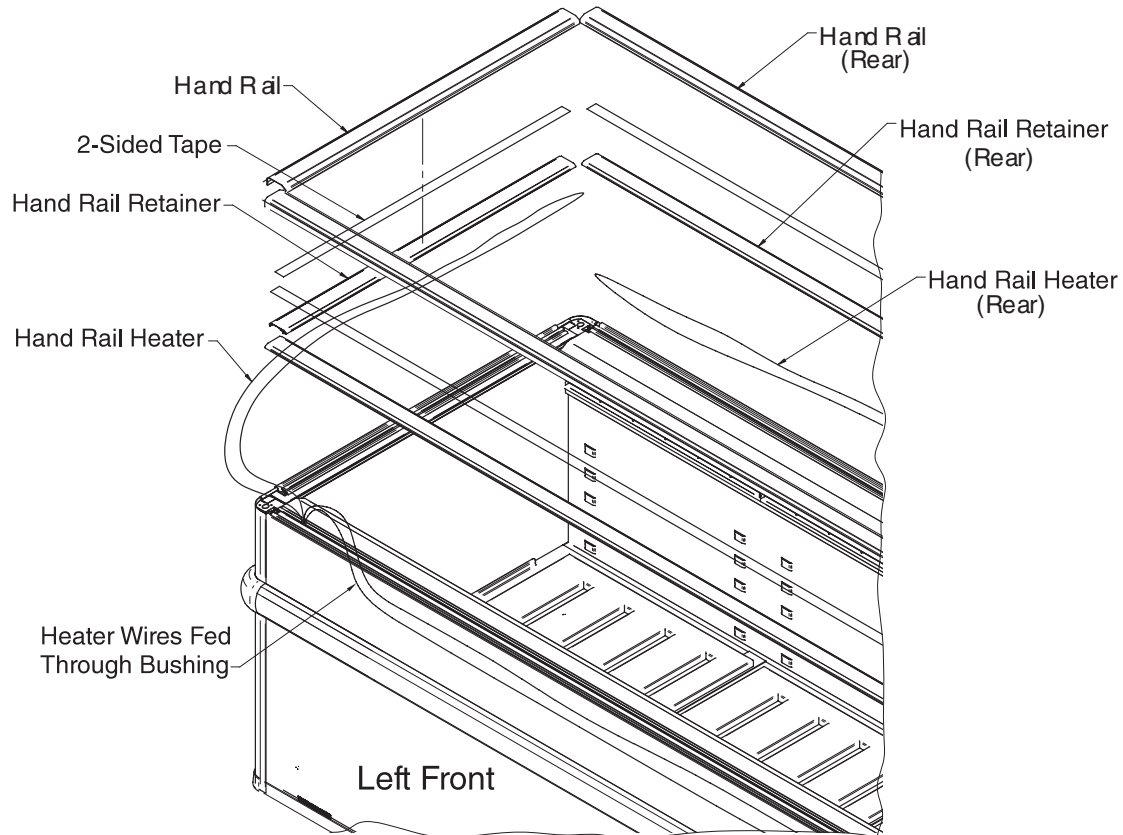

Metal top rail must be properly grounded.

Excel Open Island and Wall

Maintenance and Service

Replacing Hand Rail Heater (Glass Fronts)

To replace the heater:

1. Turn OFF the power to the merchandiser.
2. Remove wire racks, display pans, return grilles, package guard and interior panel from the compartment being serviced.

Hand rail heater connections are located in left front corner of merchandiser (near serial plate). FWEG heater connections are at right rear corner of merchandiser.

3. Remove screw and corner cap.
4. Remove screws, grounding wire harness and remove corner cap bracket.

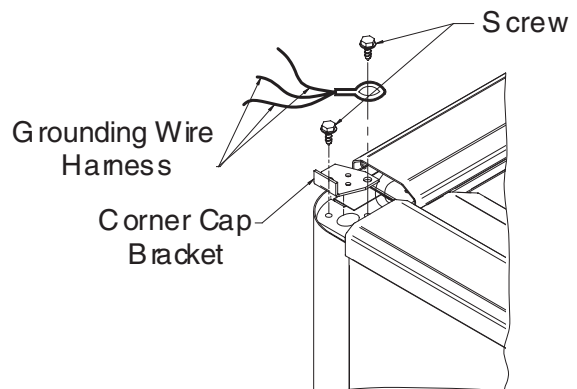
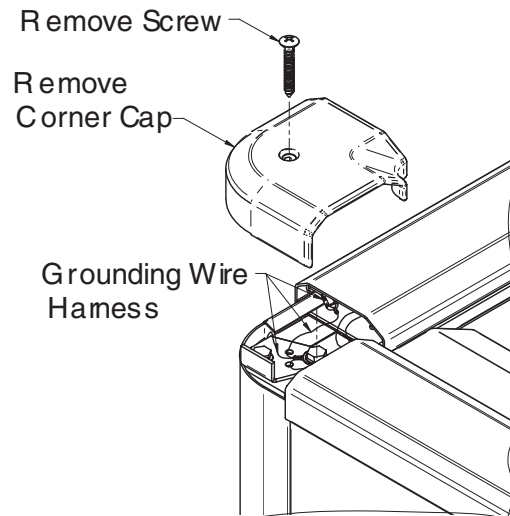
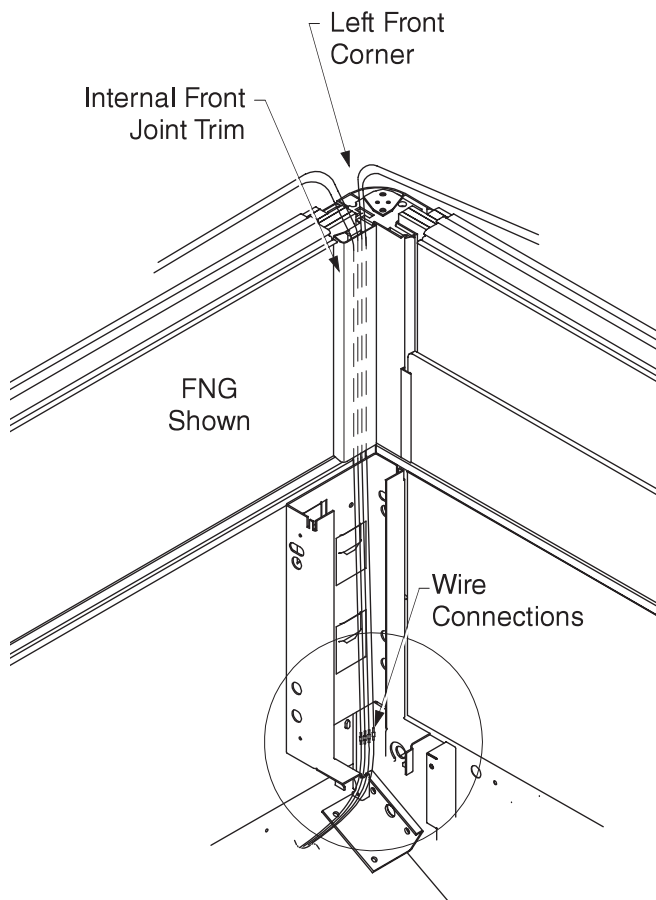

Excel Open Island and Wall Maintenance and Service

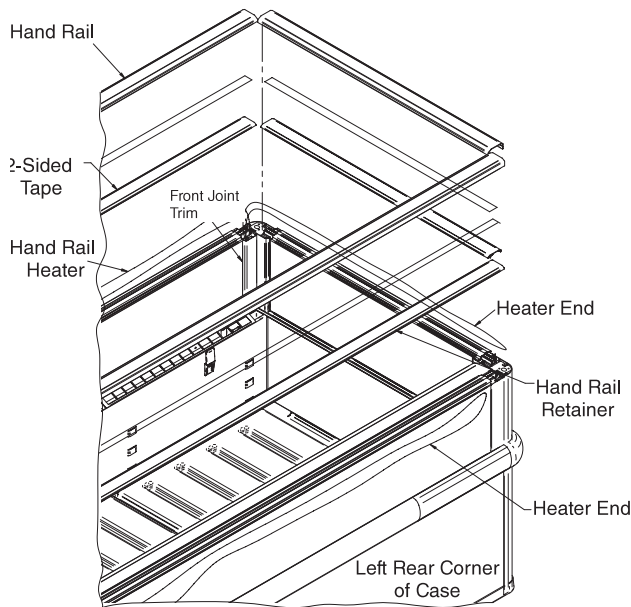

Hand Rail Heater Connections are Located in Left Front Corner of Merchandiser (Near Serial Plate)

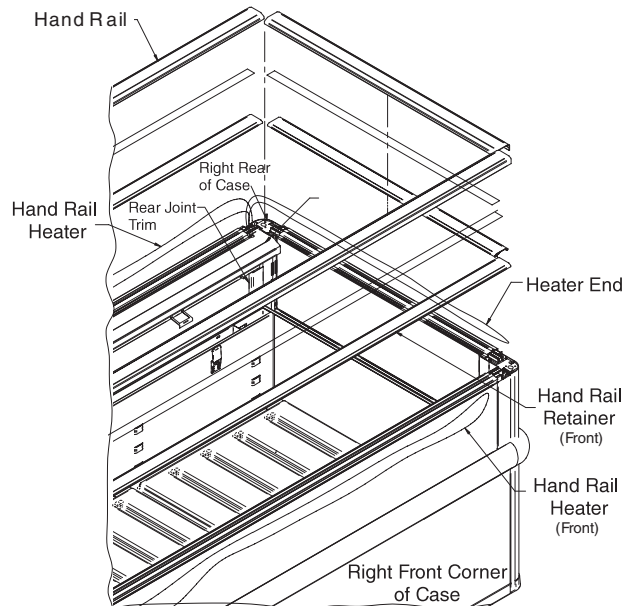

FWEG Heater Connections are at Right Rear Corner of Merchandiser

7. Disconnect and remove hand rail heater from wireway.
8. Replace heater connections and re-route new heater through internal front joint trim and onto hand rail retainers as shown.

9. Clean rail surfaces thoroughly, then install new hand rail heater.
10. Reinstall parts in reverse order. Any damaged parts must be replaced.

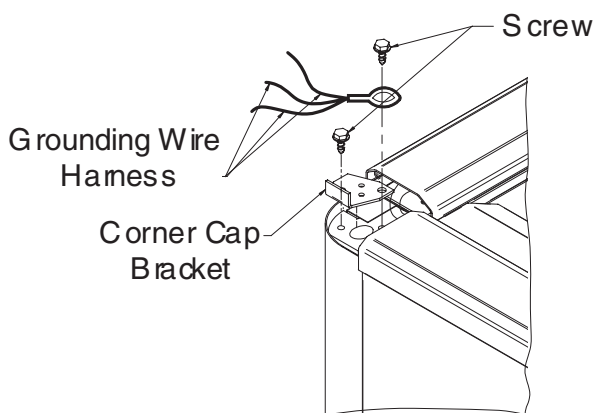

Metal top rail must be properly grounded.

⚠ WARNING

— LOCK OUT / TAG OUT —

- » To avoid serious injury or death from electrical shock, always disconnect the electrical power at the breaker when servicing or replacing any electrical component. This includes, but is not limited to, such items as doors, lights, fans, heaters, and thermostats.

Excel Open Island and Wall

Maintenance and Service

Replacing Return Air Heater

To replace the heater:

1. Turn OFF the power to the merchandiser.
2. Remove return grilles, package guard and interior panel from the compartment being serviced.
3. Remove screw and wireway cover.
4. Unplug existing return air heater. The return air heater plug is routed on RH side from front of merchandiser (end opposite the main serial plate).
5. Remove screws and retainer.
6. Remove the foil tape and heater from the retainer.
7. Clean thoroughly. Remove all adhesive and residue. Wipe surface with alcohol to ensure new heater tape will adhere properly.
8. Install new heater and tape in retainer as shown.
9. Reinstall retainer, routing plug to jumper harness; plug in.
10. Reinstall wireway cover, interior panel, package guard, return air grilles, display pans and wire racks.
11. Turn on power to merchandiser and check for proper operation.

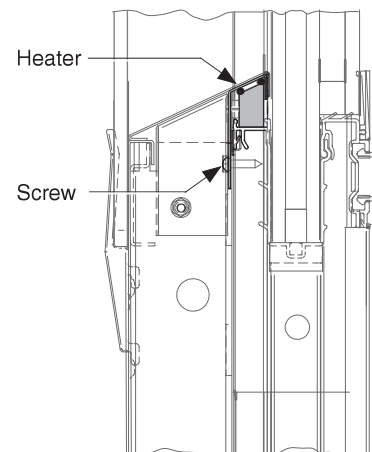
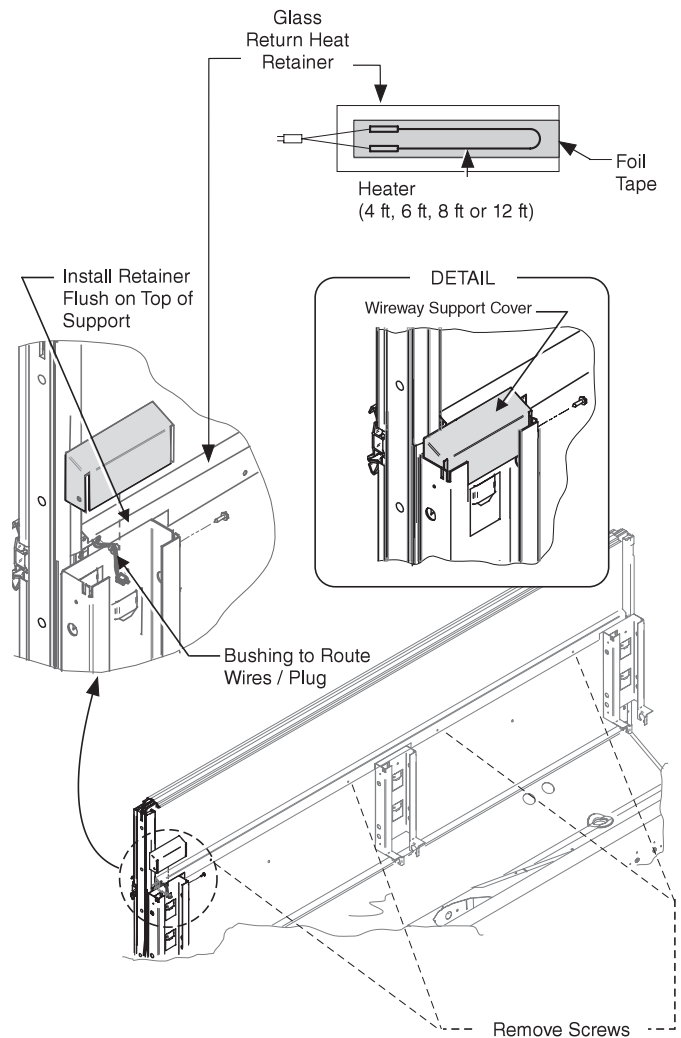

⚠ WARNING

— LOCK OUT / TAG OUT —

» To avoid serious injury or death from electrical shock, always disconnect the electrical power at the breaker when servicing or replacing any electrical component. This includes, but is not limited to, such items as doors, lights, fans, heaters, and thermostats.

Excel Open Island and Wall

Maintenance and Service

Replacing Product Side Heater (FWGH & FWEFH only)

To replace the heater:

1. Turn OFF the power to the merchandiser.
2. Remove return grilles, package guard and interior panel from the compartment being serviced.
3. Remove the pop rivets. Rivets will be drilled out. Unplug existing product side heater. Heater is routed on RH side from front of merchandiser (end opposite the main serial plate).
4. Clean thoroughly. Remove all adhesive and residue. Wipe surface with alcohol to ensure new heater tape will adhere properly.
5. Install new heater and tape in retainer as shown.
6. Reinstall retainer, routing plug to jumper harness; plug in.
7. Reinstall wireway cover, interior panel, package guard, return air grilles, display pans and wire racks.
8. Turn on power to merchandiser and check for proper operation.

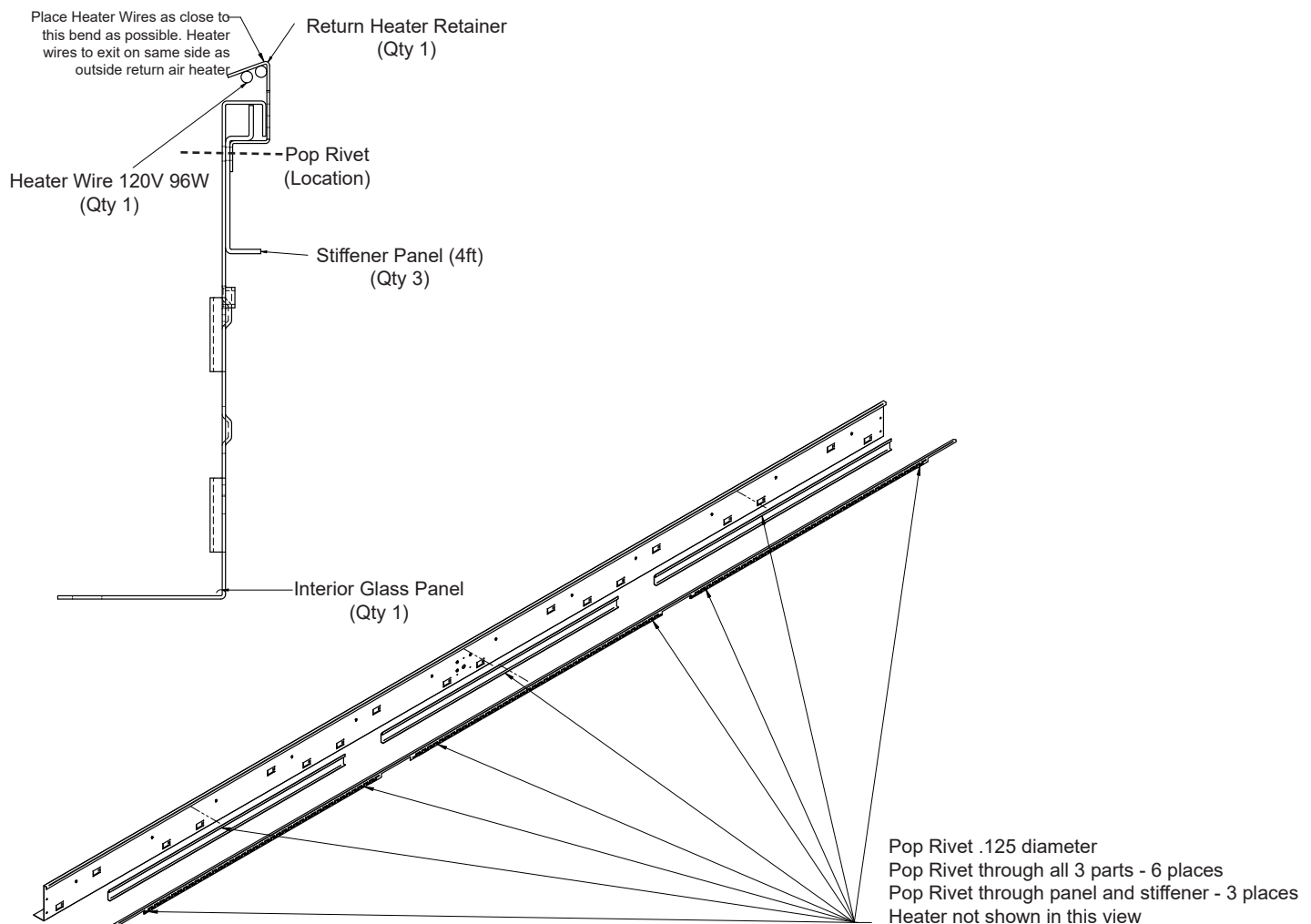

Excel Open Island and Wall Maintenance and Service

Replacing Nosing Anti-sweat Heater

To replace the heater:

1. Turn OFF the power to the merchandiser.
2. Remove a louver from one end. It doesn't matter which end.
3. Remove exterior nosing extrusion by placing fingers at the back end of the extrusion and pulling forward until it separates from the interior nosing extrusion.
4. Unplug and remove existing anti-sweat heater. The

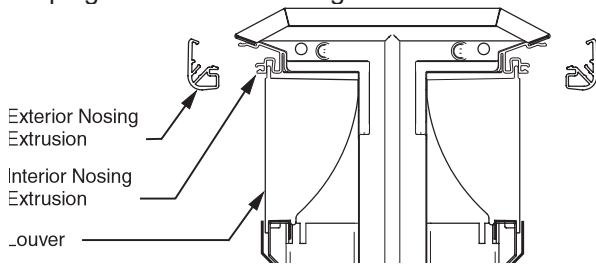

anti-sweat heater plug is routed on RH side from front of merchandiser (end opposite the main serial plate).

5. Install new anti-sweat heater as shown and route plug to jumper harness; plug in.

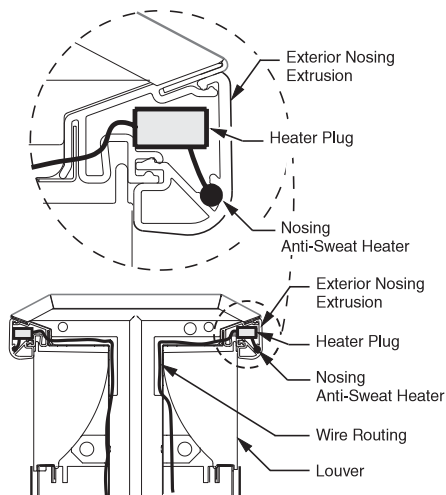

6. Do the following to reattach exterior nosing extrusion to interior nosing extrusion: There are two joining locations "A" and "B" that must be fastened to the interior nosing extrusion. "A" can be positioned in place by hand. Use a rubber mallet to snap "B" into place at interior extrusion. A light to medium tap is all that is required.

Note:

It is easier to reinstall plastic extrusion if wide PTM is removed.

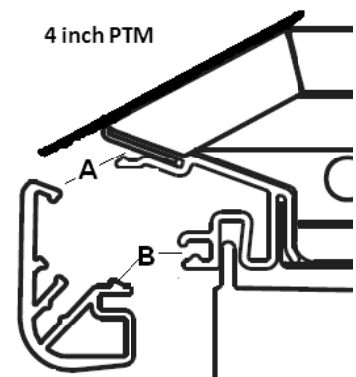

7. Replace discharge air louver, retainer and fasteners.
8. Turn on power to merchandiser, and check for proper operation.

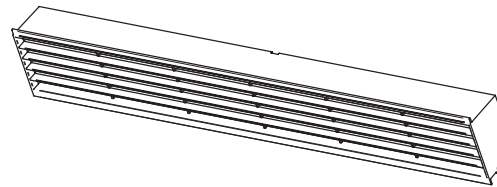

⚠ WARNING

— LOCK OUT / TAG OUT —

- » To avoid serious injury or death from electrical shock, always disconnect the electrical power at the breaker when servicing or replacing any electrical component. This includes, but is not limited to, such items as doors, lights, fans, heaters, and thermostats.

Excel Open Island and Wall Maintenance and Service

Center Flue Superstructure Anti-sweat Heater Replacement Model: FW-S

To replace the heater:

1. Turn off power to the merchandiser.
2. Remove the shelves from the section of the superstructure that requires heater replacement.
3. Unscrew, and remove the night curtain covers.

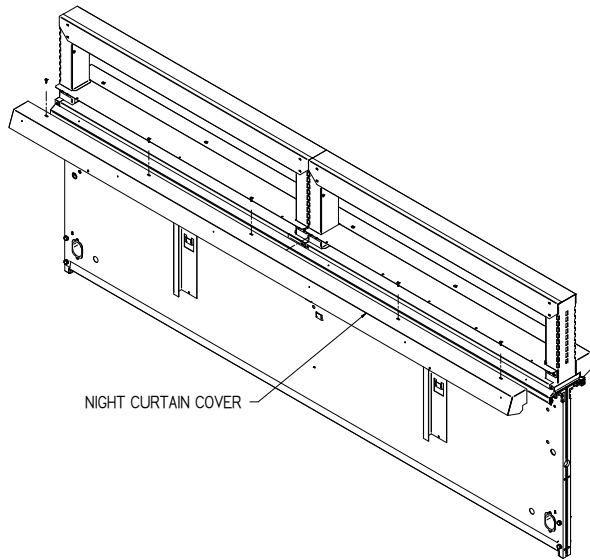

4. Remove the night curtains from the spring clip using a flat head screwdriver.
5. Unscrew and raise the center flue heater cover, and remove the center flue insulation.

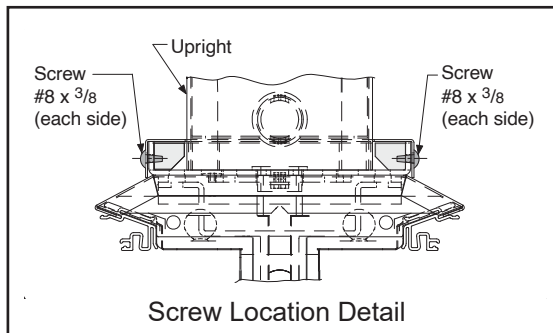

6. Unplug the heater from the anti-sweat heater supply harness, and remove it.
7. Apply the new heater to the center flue using the adhesive backing.
8. Connect the heater leads to the anti-sweat heater supply harness, and reverse the steps to install the insulation, heater cover, and night curtains.

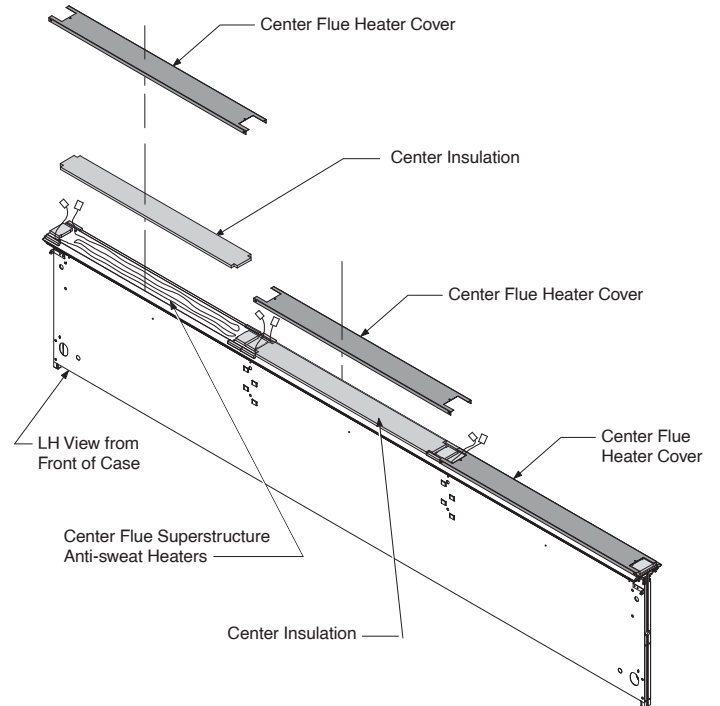

Insulation and Heater Covers (Step 5)

For clarity, the superstructure assembly is not shown.

Excel Open Island and Wall

Maintenance and Service

Replacing Drip Pan Heater

1. Turn off power to the merchandiser.
2. Remove wire racks and display pans from the compartment being serviced.
3. Unplug the heater from the heater harness.
4. Remove heater lead wire from interior panel supports.
5. Remove all screws and clips, then remove the heater.
6. Position the new heater. Apply new acrylic sealer to the underside of clips. Carefully reinstall clips in their original position.
7. Route heater lead wire through the interior panel supports.
8. Reconnect harness.
9. Turn on power to merchandiser and check for proper operation.
10. Reinstall display pans and wire racks.

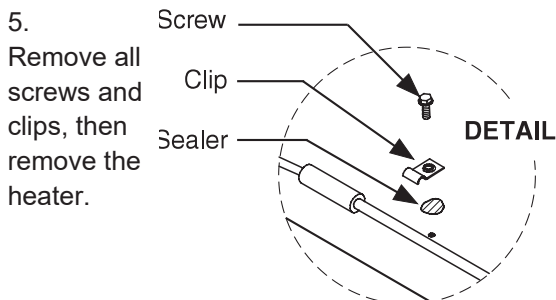
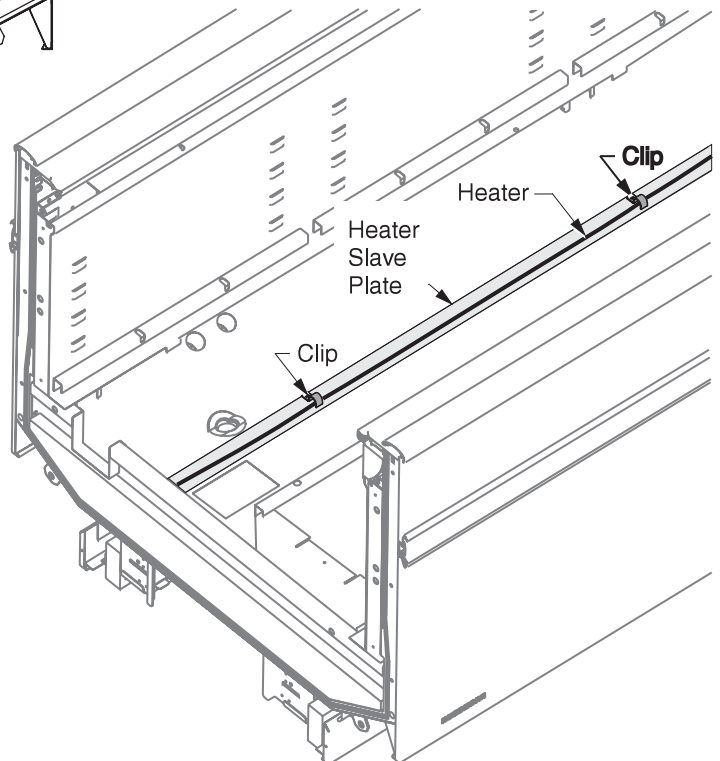
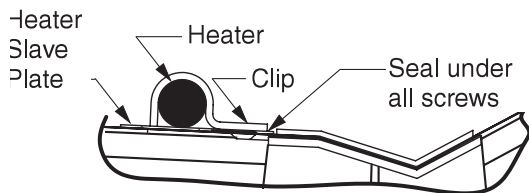
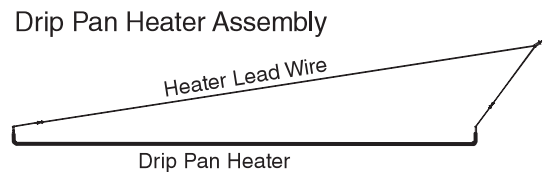
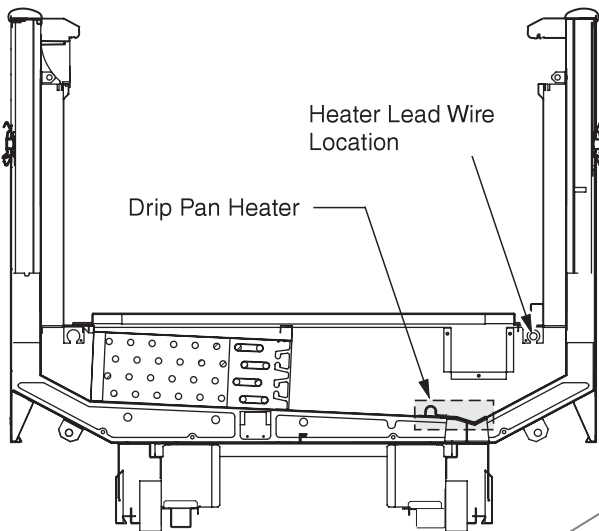

Excel Open Island and Wall

Maintenance and Service

Replacing Discharge Thermopane Glass Assembly (FNG and FIG)

Requires TWO (2) people.

Always use gloves when handling glass.

1. Turn off power to merchandiser.
2. Remove louvers, package guards, discharge rear deflector module and hand rail. Remove hand rail heater.
3. Disconnect glass pane heater lead wires from the wiring junctions.
4. With one person standing at each end of glass, lift the thermopane glass assembly straight up to remove it from its retainer channel and the end posts.
5. To install glass, have one person hold each end of the thermopane glass assembly and carefully lower it into the retainer channel and end posts.

Note:

It may be necessary to use a wide, thin tool (such as a putty knife) to keep trim from obstructing glass positioning.

6. Reconnect glass pane heater lead wires.
7. Reinstall hand rail, discharge rear deflector, package guards and louvers.
8. Turn on power. Verify that heater is working properly.

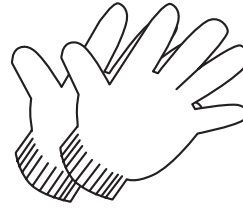

Always Use Gloves
When Handling Glass!!

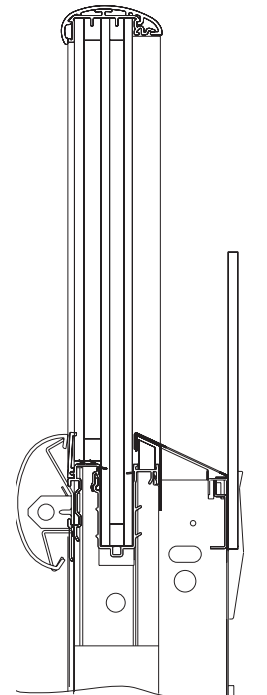

⚠️ WARNING

— LOCK OUT / TAG OUT —

- » To avoid serious injury or death from electrical shock, always disconnect the electrical power at the breaker when servicing or replacing any electrical component. This includes, but is not limited to, such items as doors, lights, fans, heaters, and thermostats.

Excel Open Island and Wall

Maintenance and Service

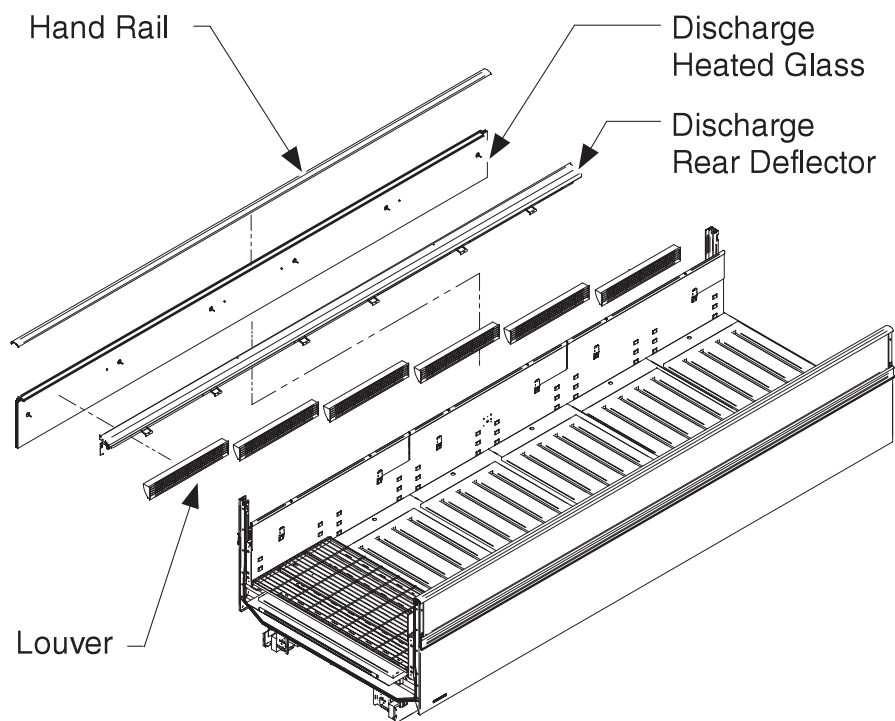
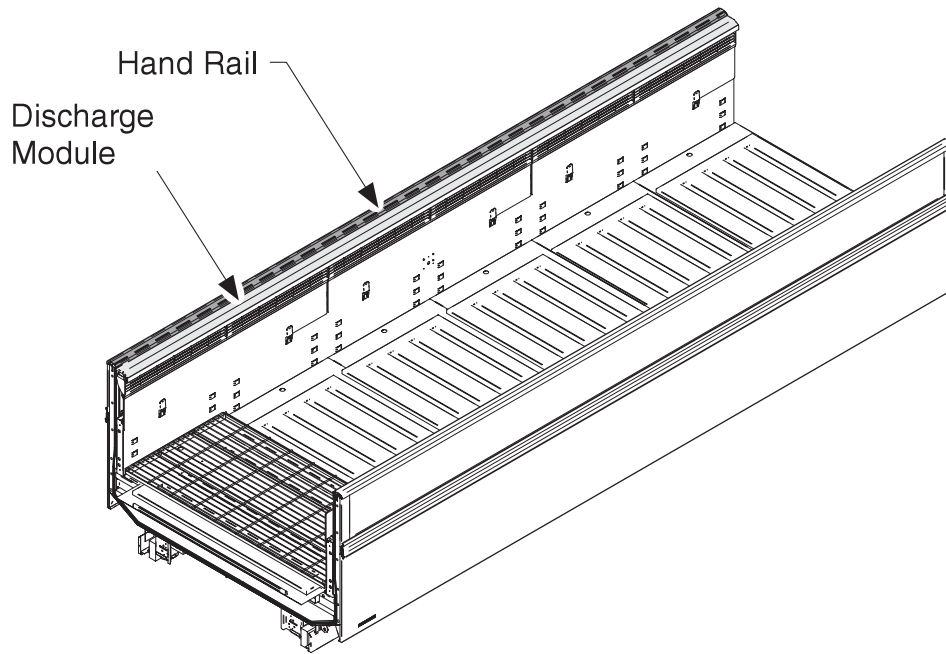

Excel Open Island and Wall Maintenance and Service

Replacing Return Thermopane Glass Assembly

Requires TWO (2) people.

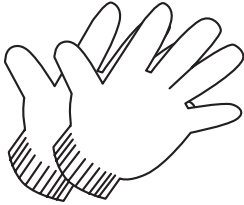

Always use gloves when handling glass.

1. Turn off power to merchandiser.
2. Remove hand rail.
3. Disconnect glass pane heater lead wires from the wiring junctions.
4. With one person standing at each end of the glass, lift the thermopane glass assembly straight up to remove it from its retainer channel and end posts.
5. To install glass, have one person hold each end of the thermopane glass assembly and carefully lower it into the retainer channel and end-posts.

Note:

It may be necessary to use a wide thin tool (such as a putty knife) to keep trim from obstructing glass positioning.

6. Reconnect glass pane heater lead wires.
7. Replace hand rail.
8. Turn on power. Verify the heater is working properly.

⚠ WARNING

— LOCK OUT / TAG OUT —

» To avoid serious injury or death from electrical shock, always disconnect the electrical power at the breaker when servicing or replacing any electrical component. This includes, but is not limited to, such items as doors, lights, fans, heaters, and thermostats.

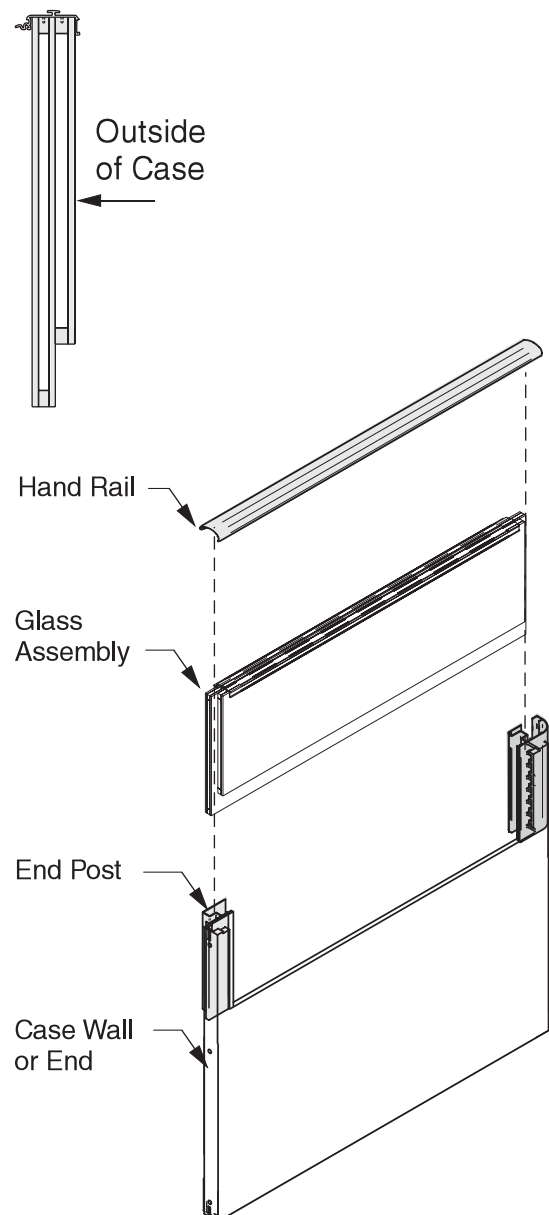

Excel Open Island and Wall

Maintenance and Service

Replacing Hand Rail

Beginning at one end, remove the hand rail by pressing down, 1, and back, 2, to release the back corner from its retainer (refer to the following illustration). Work along the back (inside) until the full length is free. Rotate the hand rail out to release the front edge.

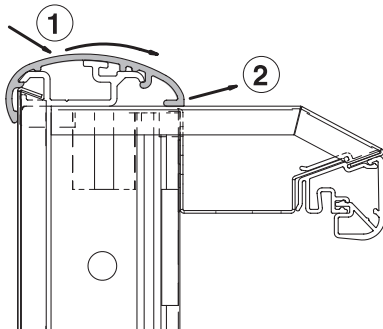

To reinstall, catch the front edge of the hand rail retainer with the inside front of the hand rail as shown in the following illustration, 1. Rotate the hand rail in toward the case and press down, 2, until back of hand rail snaps over back of retainer.

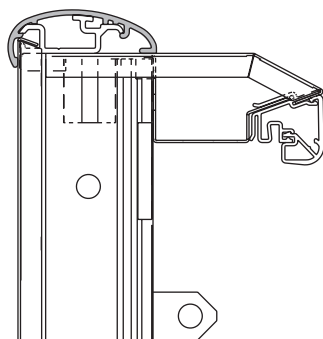
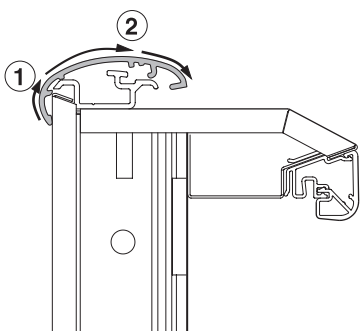

Hand Rail Snapped onto Retainer

Replacing Panel Edge Guard

Beginning at one end of the edge guard, insert a thin wide plastic tool (such as a putty knife) to separate the guard from the panel until a finger can be inserted to rotate the guard off the panel. Work the length of the panel.

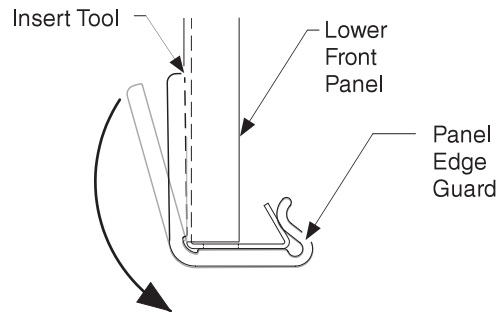

To reinstall, hook the curved leg of the edge guard behind the flange on the lower front panel. Rotate the edge guard forward to snap onto the lower front panel. Refer to the following illustrations.

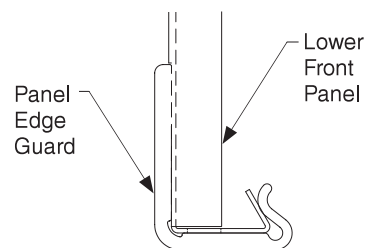
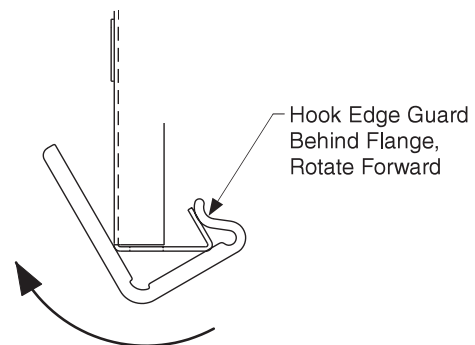

Edge Guard Snapped onto Lower Front Panel

Excel Open Island and Wall

Maintenance and Service

Superstructure LED Power Supply Replacement (FW-S)

1. Turn off power to the merchandiser.
2. Remove the raceway cover from the impacted section.
3. Unplug the power supply requiring replacement from the supply harness and LED shelf light harness
4. Install the new power supply, and connect to harnesses.
5. Replace cover.

Night Curtain Adjustment (FW-S)

The night curtain return spring can be adjusted by using a flat head screwdriver to adjust the screw located on the end of the night curtain assembly.

Turn the screw clockwise to increase tension, and counterclockwise to decrease tension.

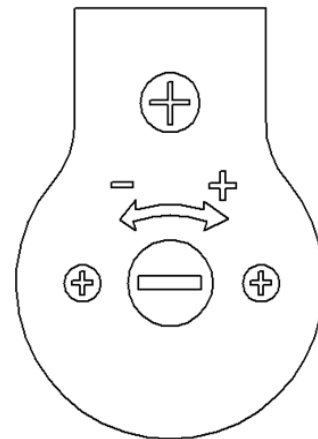

Night Curtain
(End Shown)

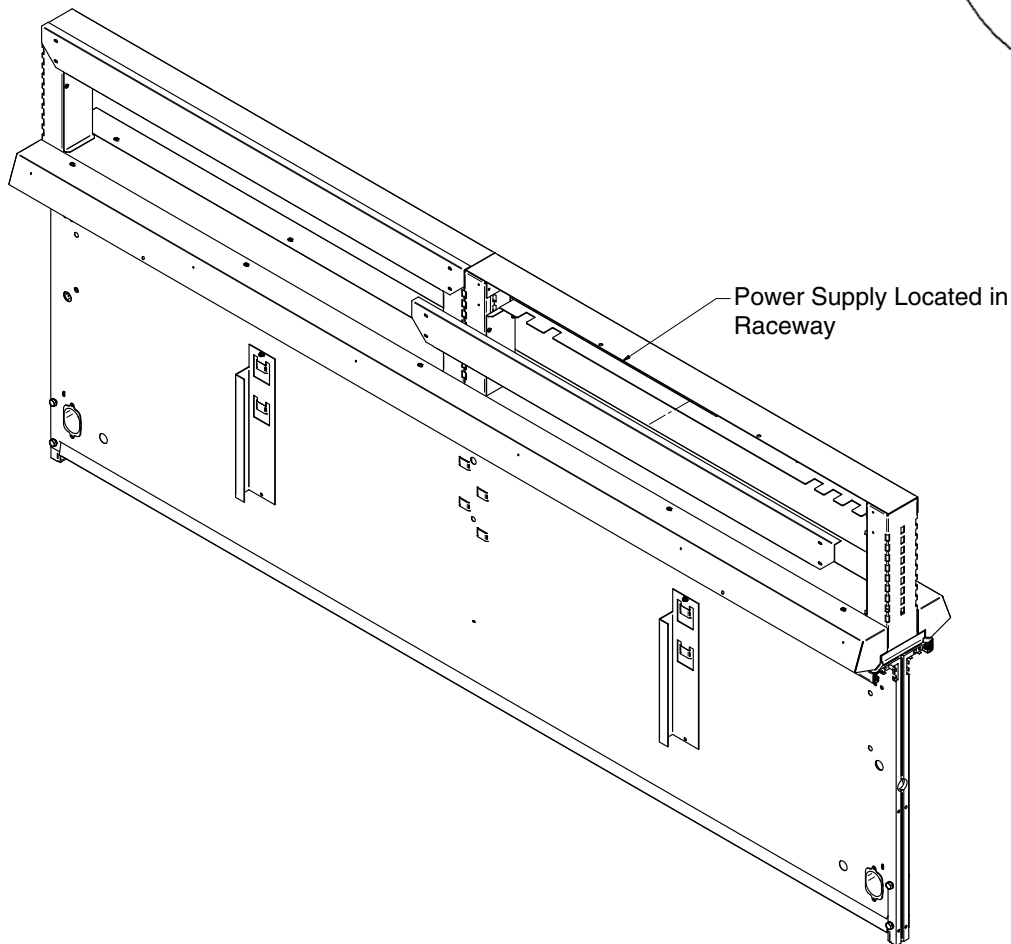

Excel Open Island and Wall

Decommissioning

Decommissioning Process

Before carrying out this procedure, it is essential that the technician is completely familiar with the equipment and all its details. It is recommended good practice that all refrigerants are recovered safely. Prior to the task being carried out, an oil and refrigerant sample should be taken in case analysis is required prior to re-use of recovered refrigerant. It is essential that electrical power is available before the task is commenced.

- a. Become familiar with the equipment and its operation.
- b. Isolate the system electrically.
- c. Before attempting the procedure, ensure:
 - i. Mechanical handling equipment is available, if required, for handling refrigerant cylinders.
 - ii. All personal protective equipment is available and being used correctly.
 - iii. The recovery process is supervised at all times by a qualified, competent person.
 - iv. Recovery equipment and cylinders conform to the appropriate standards.
- d. Pump down refrigerant system, if possible.
- e. If a vacuum is not possible, make a manifold so that refrigerant can be removed from various parts of the system.
- f. Make sure that cylinder is situated on the scales before recovery takes place.
- g. Start the recovery machine and operate in accordance with instructions.
- h. Do not overfill cylinders (no more than 80% volume liquid charge).
- i. Do not exceed the maximum working pressure of the cylinder, even temporarily.
- j. When the cylinders have been filled correctly and the process completed, make sure that the cylinders and the equipment are removed from site promptly and all isolation valves on the equipment are closed off.
- k. Recovered refrigerant shall not be charged into another refrigerating system unless it has been cleaned and checked.

Equipment shall be labeled stating that it has been decommissioned and emptied of refrigerant. The label shall be dated and signed. For appliances containing flammable refrigerants, ensure that there are labels on the equipment stating the equipment contains flammable refrigerant.

Warranty

To obtain warranty information or other support, contact your Hussmann representative or visit:

<https://www.hussmann.com/services/warranty>.

Please include the model and serial number of the product.

For questions about your equipment, please contact our Technical Support Team at 1-866-785-8499

For general support or service calls, contact our Customer Support Call Center at 1-800-922-1919

For ordering aftermarket warranty parts, call 1-855-HussPrt (1-855-487-7778) or email the following address:

Hussmann_part_warranty@hussmann.com

Revision History

Revision R: Redesign; added A2L refrigerants

Revision P:

Added FW-S Service instructions for night curtain, anti-sweat heaters, and LED power supply

Revision K:

Updated UL Listing, Page 1-1; California Warning, Page 1-2; Updated, Page 1-21; Refrigerant, Page 2-1



Scan the QR code on your mobile device to access additional product information or order parts.

Parts may also be ordered at:

parts.hussmann.com

Call toll free: 1.855.487.7778

We reserve the right to change or revise specifications and product design in connection with any feature of our products. Such changes do not entitle the buyer to corresponding changes, improvements, additions or replacements for equipment previously sold or shipped.