

Reach-In Merchandisers

Medium & Low Temperature

Installation, Operation and Service Manual

Use this manual with Insight Reach-In Case Manual 3181178



INSIGHT® REACH-IN DOORS

September 2023
P/N 3182257_A
Spanish P/N 3182258_A
MANUAL - IO Insight Reach-In Doors

BEFORE YOU BEGIN

READ THESE INSTRUCTIONS COMPLETELY AND CAREFULLY.

This manual was written in accordance with originally prescribed equipment that is subject to change. Hussmann reserves the right to change or revise specifications and product design in connection with any feature of our products.

SAFETY INSTRUCTIONS



Personal Protection Equipment (PPE) is required. Wear safety glasses, gloves, protective boots or shoes, long pants, and a long-sleeve shirt when working with this equipment and while handling glass.

SAFETY INSTRUCTIONS

The safety of our customers and employees is paramount. The precautions and procedures described in this manual are intended as general methods for safe use of this equipment. Please be sure to comply with the precautions described in this manual to protect you and others from possible harm.

Only qualified personnel should install and service this equipment. Observe all precautions on tags, stickers, labels and literature attached to this equipment.

Service is only to be performed by factory-authorized service personnel, so as to minimize the risk of possible ignition due to incorrect parts or improper service. Component parts shall be replaced with like components. Contact your Hussmann representative to arrange servicing.

The definitions below are used to clarify the magnitude and urgency of harm and damage, considering problems arising from misuse. Relative to their potential danger, the definitions are divided into five parts according to ANSI Z535 Series.

ANSI Z535.5 DEFINITIONS

DANGER

DANGER indicates a hazardous situation which, if not avoided, will result in death or serious injury.

WARNING

WARNING indicates a hazardous situation which, if not avoided, could result in death or serious injury.

CAUTION

CAUTION indicates a hazardous situation which, if not avoided, could result in minor or moderate injury.

NOTICE

NOTICE is used to address practices not related to personal injury.

SAFETY INSTRUCTIONS

SAFETY INSTRUCTIONS (or equivalent) signs indicate specific safety-related instructions or procedures.



This warning does not mean that Hussmann products will cause cancer or reproductive harm, or is in violation of any product-safety standards or requirements. As clarified by the California State Government, Proposition 65 can be considered more of a 'right to know' law than a pure product safety law. When used as designed, Hussmann believes that our products are not harmful. We provide the Proposition 65 warning to stay in compliance with California State law. It is your responsibility to provide accurate Proposition 65 warning labels to your customers when necessary. For more information on Proposition 65, please visit the California State Government Website.

TABLE OF CONTENTS

BEFORE YOU BEGIN	II
Read these instructions completely and carefully	ii
Safety Instructions	ii
ANSI Z535.5 Definitions.....	ii
TABLE OF CONTENTS	III
Case Clearance	iv
Shipping Damage	iv
Revision History.....	iv
NEW CASE INSTALLATIONS	1-1
Door Configurations.....	1-1
Case Leveling	1-1
Remove Protective Film & Shipping Braces.....	1-1
Door Alignment Test	1-2
Adjusting Door & Frame Alignment	1-3
Adjusting Closing Torque	1-4
Conditioning Gaskets	1-5
Installing Joint Trim.....	1-6
DOOR SERVICE AND MAINTENANCE	2-1
Replacement Parts List	2-1
Removing Door(s)	2-3
Installing Door(s)	2-4
Converting a LH door into to a RH door:	2-6
Door Bumpers.....	2-7
Torsion rod replacement for LH door:	2-8
Replacing a Door Cam.....	2-10
Replacing Door Handle(s)	2-11
Replacing LED Lighting.....	2-14
Replacing LEDs (Continued).....	2-15
Replacing Power Supply(s)	2-18
Replacing Magnetic Gasket	2-19
Restoring Gasket Seal.....	2-20
Cleaning Anti-Fog Glass Doors	2-22
Warranty & Support.....	2-22

CASE CLEARANCE

A 4-inch (102 mm) space between the rear of the merchandiser and wall must be maintained for air circulation. However, in high ambient conditions, sweating may still occur. If this happens install a method of forced ventilation such as a fan ventilation kit.

ATTENTION

- Merchandiser must operate for 24 hours before loading product!
- Regularly check merchandiser temperatures.
- Do not break the cold chain. Keep products in freezer or cooler before loading into merchandiser.
- Medium temperature merchandisers are designed for loading ONLY pre-chilled products.
- Low temperature merchandisers are designed for loading ONLY frozen products.

SHIPPING DAMAGE

All equipment should be thoroughly examined for shipping damage before and during unloading. This equipment has been carefully inspected at our factory. Any claim for loss or damage must be made to the carrier. The carrier will provide any necessary inspection reports and/or claim forms.

Apparent Loss or Damage

If there is an obvious loss or damage, it must be noted on the freight bill or express receipt and signed by the carrier's agent; otherwise, carrier may refuse claim. The carrier will supply necessary forms.

Concealed Loss or Damage

A claim for concealed damage is made when loss or damage is not apparent until after equipment is removed from its shipping crate. Upon discovering damage, make request in writing to carrier for inspection within 15 days and retain all packing. The carrier will supply inspection report and required claim forms.

REVISION HISTORY

REVISION A — April 2023 - Original Issue

⚠️ WARNING

- » Excessive ambient conditions may cause condensation and therefore sweating of doors. Facility operators should monitor doors and floor conditions to ensure safety of persons.
- » Case ventilation openings must be clear of any obstructions. Do not damage the refrigerant circuit.
- » Always disconnect the electrical power at the main disconnect when servicing or replacing any electrical component. This includes, but is not limited to, such items as fans, heaters, thermostats, doors and lights.
- » Do not use mechanical devices or other means to accelerate the defrosting process.
- » Do not use electrical appliances inside the food storage compartments of the case(s).
- » Do not store items or flammable materials atop the unit. Do not walk on case.

NEW CASE INSTALLATIONS

DOOR CONFIGURATIONS

Doors may be configured on the case as shown below.

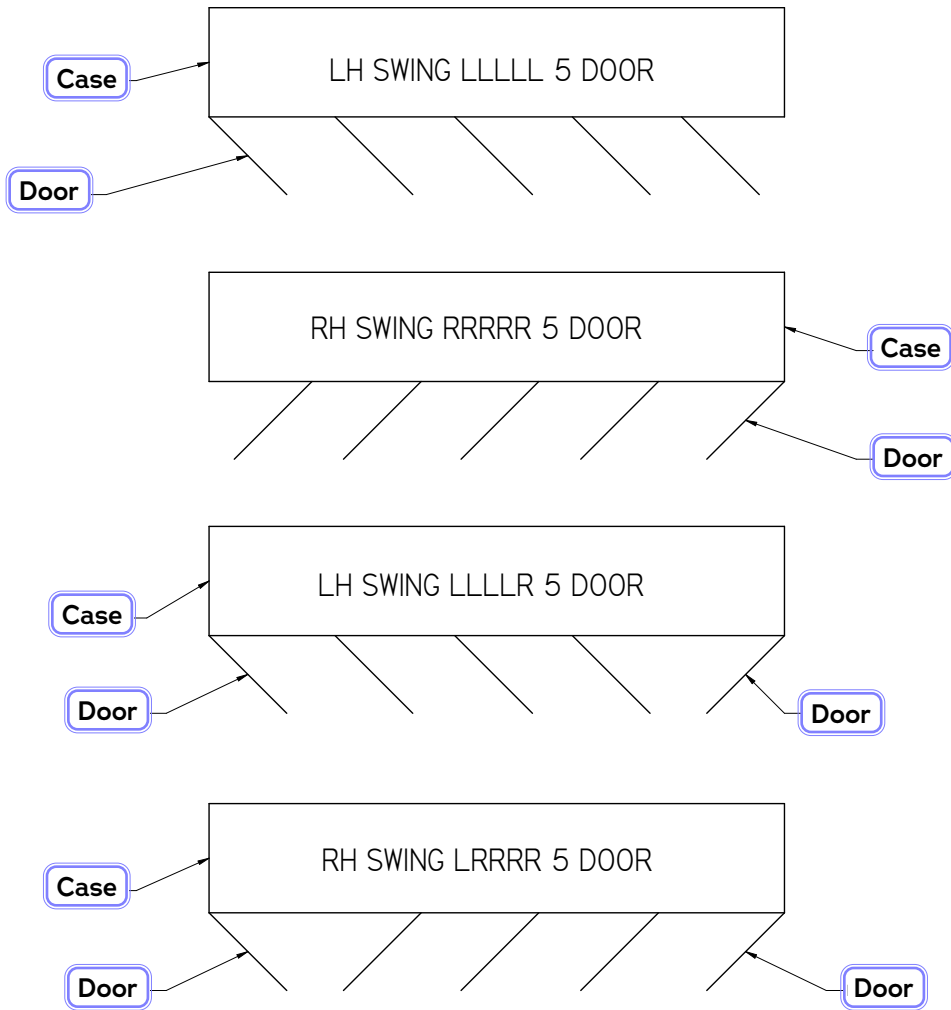

CASE LEVELING

Case must be leveled and joined together according to the installation instructions for Insight® Reach-in Merchandisers. Check if the case(s) are level, or if the floor is uneven, and if not, some shimming of the case may be required.

REMOVE PROTECTIVE FILM & SHIPPING BRACES

Make sure to remove protective film from the doors. The film was applied only for use during shipment. Remove shipping braces from the top and bottom of each door. Remove any packaging, shipping straps, or tape from the doors.

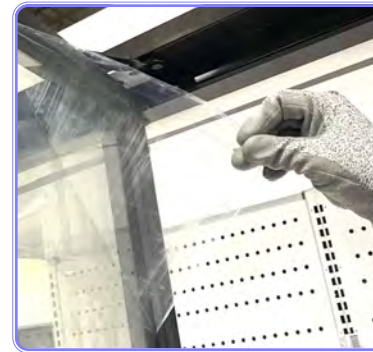

Remove protective door film.

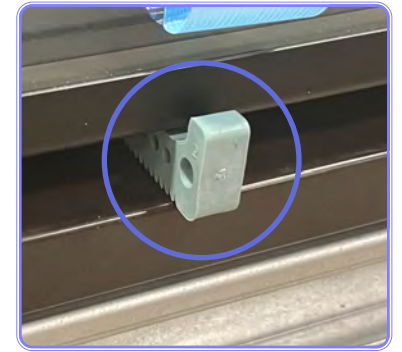

Remove shipping brace from doors.

See Page 2-21 for instructions for cleaning anti-fog glass doors.

DOOR ALIGNMENT TEST

If the cases are not level, the doors may not look aligned correctly. Check that the floor and cases are level, and if not, additional shimming may be required.

Make sure the door gasket is fully sealing around the door. One method to do this is to insert a dollar bill between the gaskets around the door perimeter with the doors closed. There should be some resistance in all locations when pulling on the dollar bill.

Fix door alignment issues by moving the bottom hinge assembly. Check if the door is square with the opening, and adjust the location of the pivot at the bottom of the door if necessary.

Ensure gaskets are fully inserted on the door.

If the gaskets are not fully inserted, it may cause an air leak or ice, and the gasket cycle life may be reduced.

NOTICE

It is the installing contractor's responsibility to consult local agencies for local code requirements.



Dollar Bill Door Test

ADJUSTING DOOR & FRAME ALIGNMENT

Torsion plate can be modulated to assist in door alignment.

1. Remove torsion plate cover.
2. Slide plate left or right and tighten screws to adjust the sawtooth, providing the proper alignment for the doors. An impact driver must be used to perform this procedure. If you do not have an impact driver tighten to 100 - 110 inch lbs. The torsion plate bolts use Torx T-27 bit.
3. Replace cover.

MOVE BOTTOM TORSION PLATE TO RIGHT

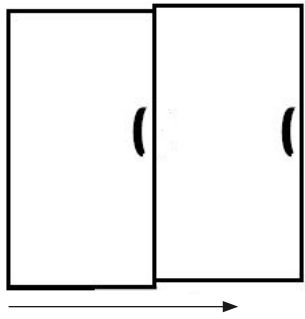

MOVE BOTTOM TORSION PLATE TO LEFT

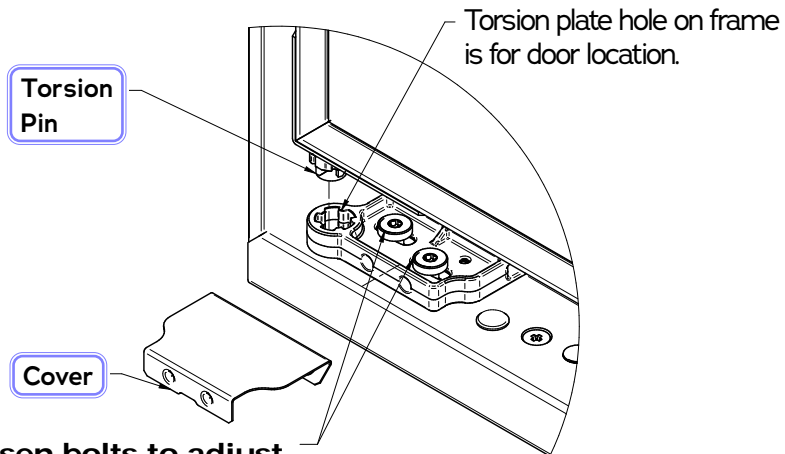
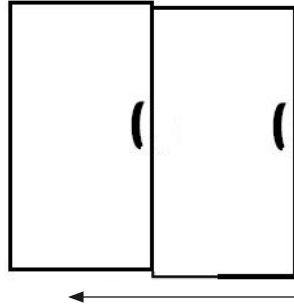

Loosen bolts to adjust sawtooth.

Left door needs to be shifted up to white line so that it is even with right door.

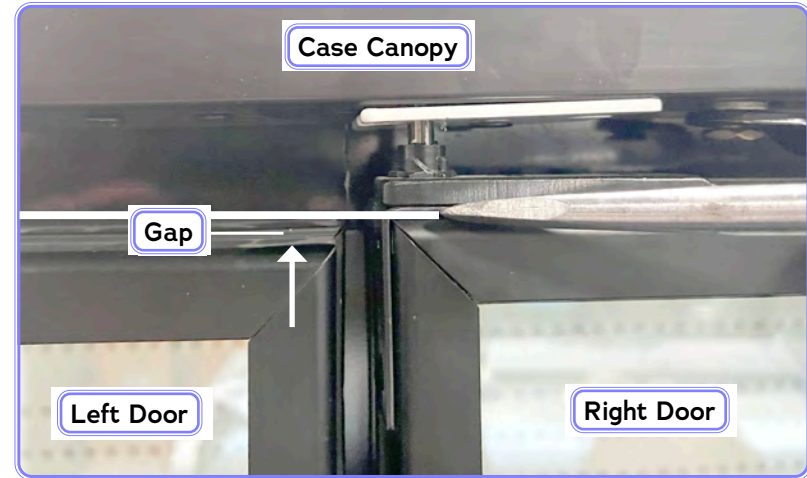

Use a screwdriver to remove torsion plate cover as shown. The plate slides out to the right away from the door.

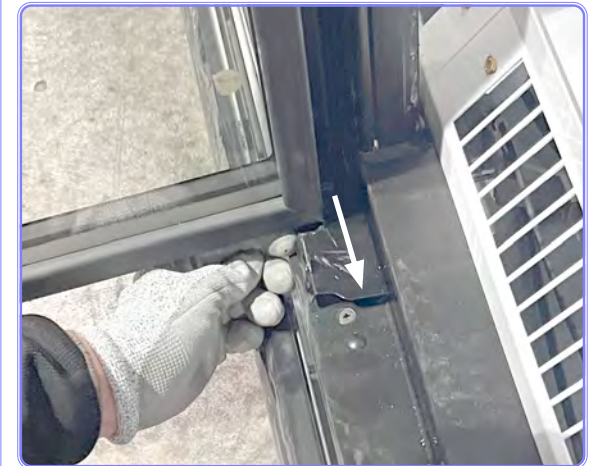

ADJUSTING CLOSING TORQUE

The door may also be field adjusted using a 9/16" wrench. A thin wrench is recommended for making these adjustments. The door's closing speed is factory adjusted and is set to three audible clicks.

To field adjust the door closing speed:

Unsnap the cover from the torsion plate using a flathead screwdriver. The torsion should be set in the hole. Turn the wrench toward the door handle to increase door closing tension. For doors that do not have any tension already applied, the suggested torque is 2-4 clicks. For doors that may need adjustment after they are factory set, tighten no more than 1 additional click.

NOTE:

Do not over-torque the torsion pin. Excessive torque (over 1 full turn) will result in damage to the spring assemble and/or door. Do not use wrench to decrease door tension as this may damage the hinge plate assembly.

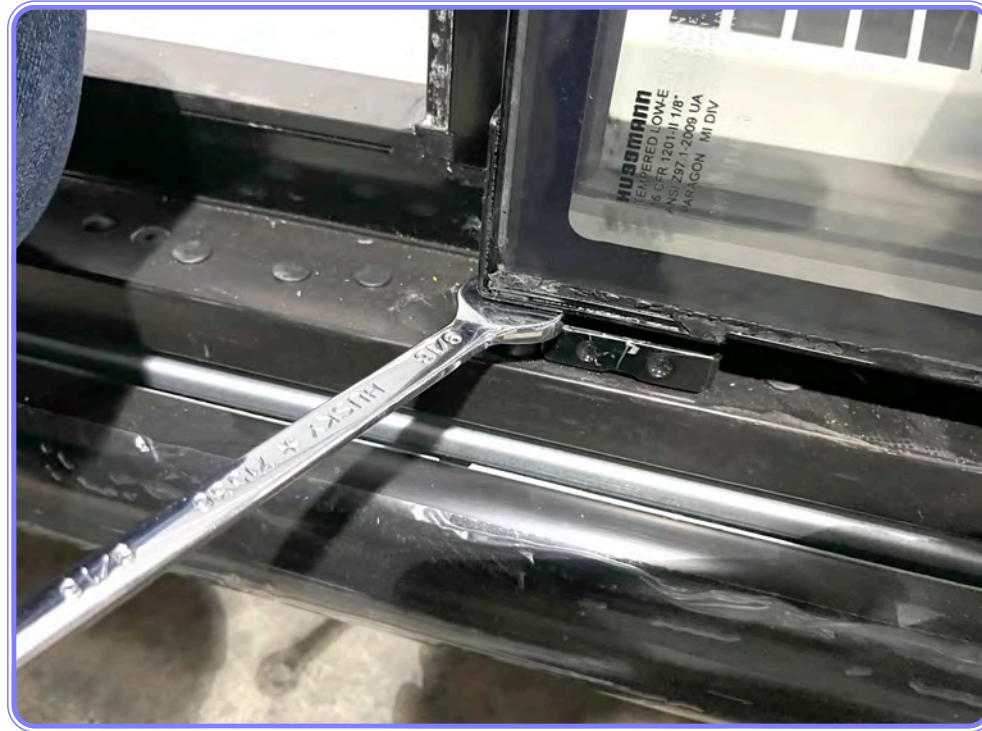

Adjust door closing torque using a slim 9/16" wrench.

CONDITIONING GASKETS

(Center & End Door Mullions)

The manufacturer cannot control the environment surrounding cases during shipment. Temperature and humidity fluctuations during shipment and excessive vibration may promote gaps between the gasket and frame. These gaps prevent gaskets from sealing even when correctly fitted at the factory. This is not a warranty issue or defect.

Follow this procedure to ensure gaps close, and gaskets seal properly:

1. Remove all shipping retainers and all packing material.
2. Close each door. Use a flashlight to identify any gaps between the frame and the gasket.
3. Energize all anti-sweat, fan, and light circuits for at least two hours, but at most four hours, before initiating the refrigeration cycle.
4. Monitor all gaps. If gaps remain at the end of four hours, follow the procedure for Restoring Gasket Seal as detailed in the Service Section of this manual.
5. Initiate cooling sequence once gaps disappear.

Do not exceed 8 hours of energized circuits without refrigeration. Doing so may cause damage to the case and will void the warranty.

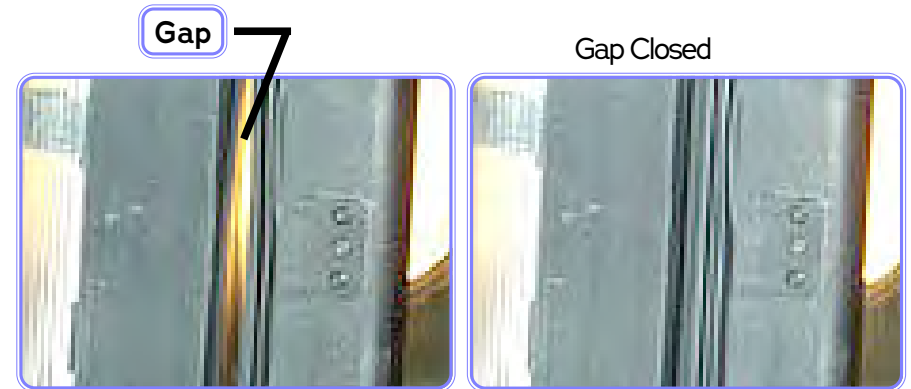

Before and After Gasket Conditioning

NOTICE

To ensure proper door gasket seal - Remove all shipping retainers and energize all anti-sweat, fan & light circuits 2 to 4 hours prior to initiating refrigeration cycle.

No not exceed 8 hours of energized circuits without refrigeration. Damage or product failure may occur and void the warranty.

INSTALLING JOINT TRIM

T-moulding needs to be installed between the joints in case lineups.

1. Align holes in frame with holes in Joint Molding – 1.
2. Fasten cases together using Binder Post and Screws – 2 as shown below.

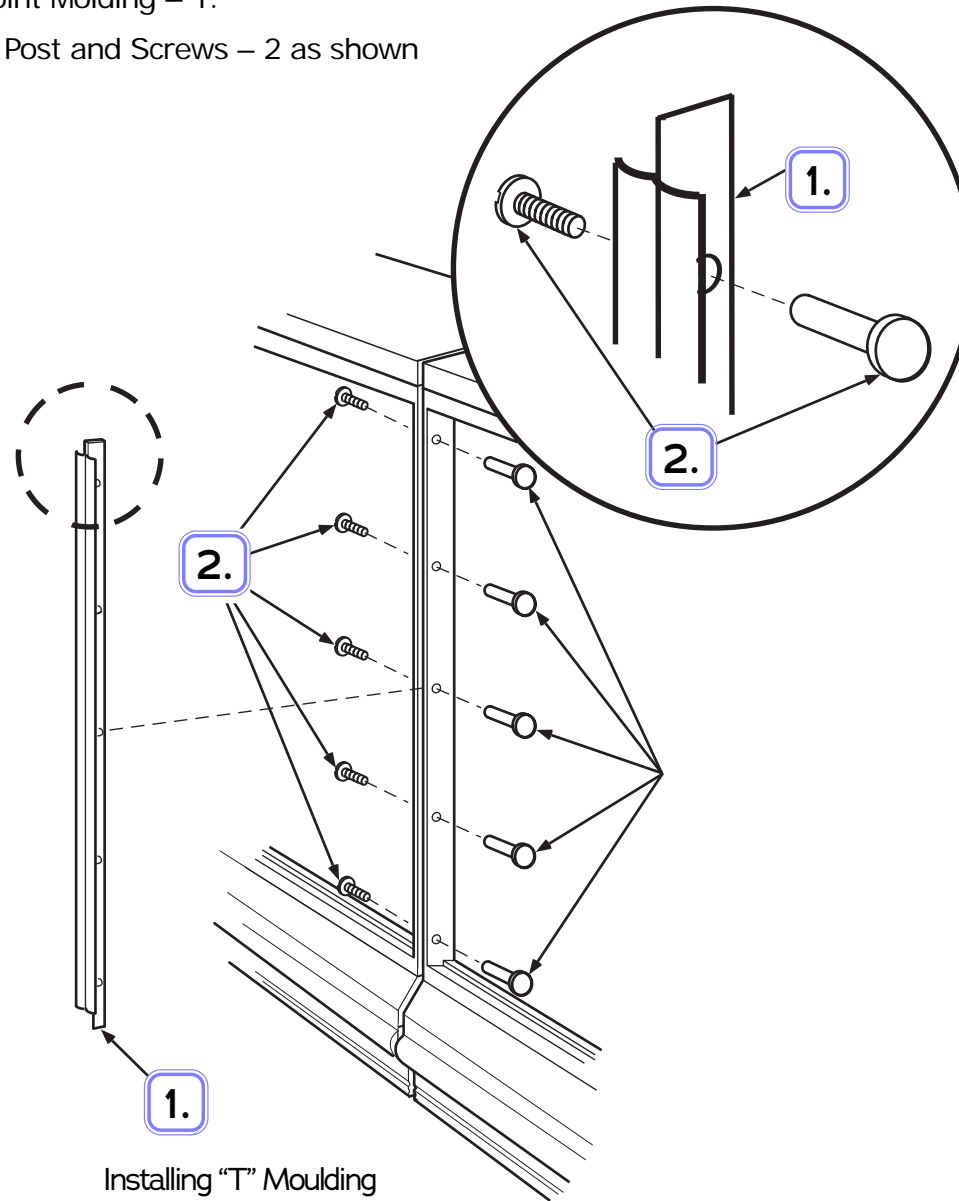

Installing "T" Moulding

DOOR SERVICE AND MAINTENANCE

REPLACEMENT PARTS LIST

Part numbers and parts are subject to change. See Warranty and Support Section of this manual for contact information.

PART LIST - ASSEMBLY			
Item Number	Document Number	Title	Quantity
1	SEE NOTE 5	DOOR ASSY-ECOVISION HDL	1 THRU 6 DOOR
2	3155340	SCREW-8-32 X .125 SST KNURL GRIP CUP POINT SET	2 PER DOOR
3	3146431	BEARING-.250 ID X .375 L OIL-EMBD SLEEVE	2 PER DOOR
4	SEE NOTE 5	PIN-TORSION DOOR LH	1 PER DOOR
5	SEE NOTE 5	PIN-TORSION DOOR RH	1 PER DOOR
6	SEE NOTE 5	ROD-TORSION DOOR	1 PER DOOR
7	3146430	BEARING-.375 ID X .625 OD OIL-EMBD THRUST	1 PER DOOR
8	1000001206	BOLT-.250-28 X .188 SHLDR HEX HD TOP DOOR CAM	1 PER DOOR
9	3119359	STUD-SST HANDLE	2 PER DOOR
10	0526059	SCREW-SET 8-32 X 1/2 SS CUP PT	2 PER DOOR
11	SEE NOTE 5	HANDLE ASM-THIN ECOVISION DOOR	1 PER DOOR
12	SEE NOTE 5	GASKET-DOOR 30.13 WD X 72.25 HGT	1 PER DOOR
13	SEE NOTE 5	HEATER-FRAME VARIABLE	1 PER FRAME
14	1000001325	BOLT-.250-28 X .250 SHLDR HEX HD TOP DOOR CAM	1 PER DOOR
15	SEE NOTE 5	RETAINER DOOR	1 PER DOOR
16	3159906	WASHER-.344 ID X .625 OD X .098 THICK SST FLAT	1 PER DOOR
17	3173469	PIN-TOP DOOR BLK	1 PER DOOR
18	3173413	WASHER-EXTERNAL TOOTH LOCK .256 ID X .51 OD	1 PER DOOR
19	3173414	LOCKNUT-HEX .250-28 NYLON INSERT	1 PER DOOR
20	3173415	RING-RETAINING E TYPE .187 SHAFT OD	1 PER DOOR
21	SEE NOTE 5	LED-S GE LH	1 PER FRAME
22	SEE NOTE 5	LED-S GE CTR	# OF DOORS -1
23	SEE NOTE 5	LED-S GE RH	1 PER FRAME
24*	0482328000	TAPE-VHB 1X72Y .025THK 14 INCHES @ THREE PLACES PER LAMP	.305 METERS PER LAMP
25*	1900679	SCREW-SM 8 X 3/4 PHIL PAN HD TEK 2	2 PER LAMP
26*	0518511	GREASE-DOOR HOLD OPEN CAM CLEAR FM (PER CAM RETAINER)	0.02 OUNCE PER DOOR REATINER
27*	3173118	ACTIVATOR-LOCTITE SF 7387	1 SPRAY PER STUD
28*	3173119	ADHESIVE-LOCTITE AA 392	2 DROPS PER STUD
29	SEE NOTE 5	BRACKET-DOOR BUMPER	2 PER DOOR
30	3189533	BUMPER-.188 ID X .078 THK SBR RUBBER PUSH IN	4 PER DOOR
31	SEE NOTE 5	PLATE-TOP PIN RETAINER	1 PER DOOR
32	SEE NOTE 5	PLATE-TORSION PIN BOT	1 PER DOOR
33	SEE NOTE 5	COVER-BOT TORSION PIN PLATE	1 PER DOOR

* INDICATES ITEM NOT SHOWN

- NOTES:
 1. APPLICABLE STANDARDS / SPECIFICATIONS
 ASME Y14.5M-1994, DIMENSIONS AND TOLERANCES
 2. KEY PRODUCT CHARACTERISTICS PER EPR-0006 & IDENTIFIED WITH SYMBOL 
 3. MATERIAL-
 4. REF NEW PART
 5. SEE LIST 3174787 FOR REPLACEMENT PARTS

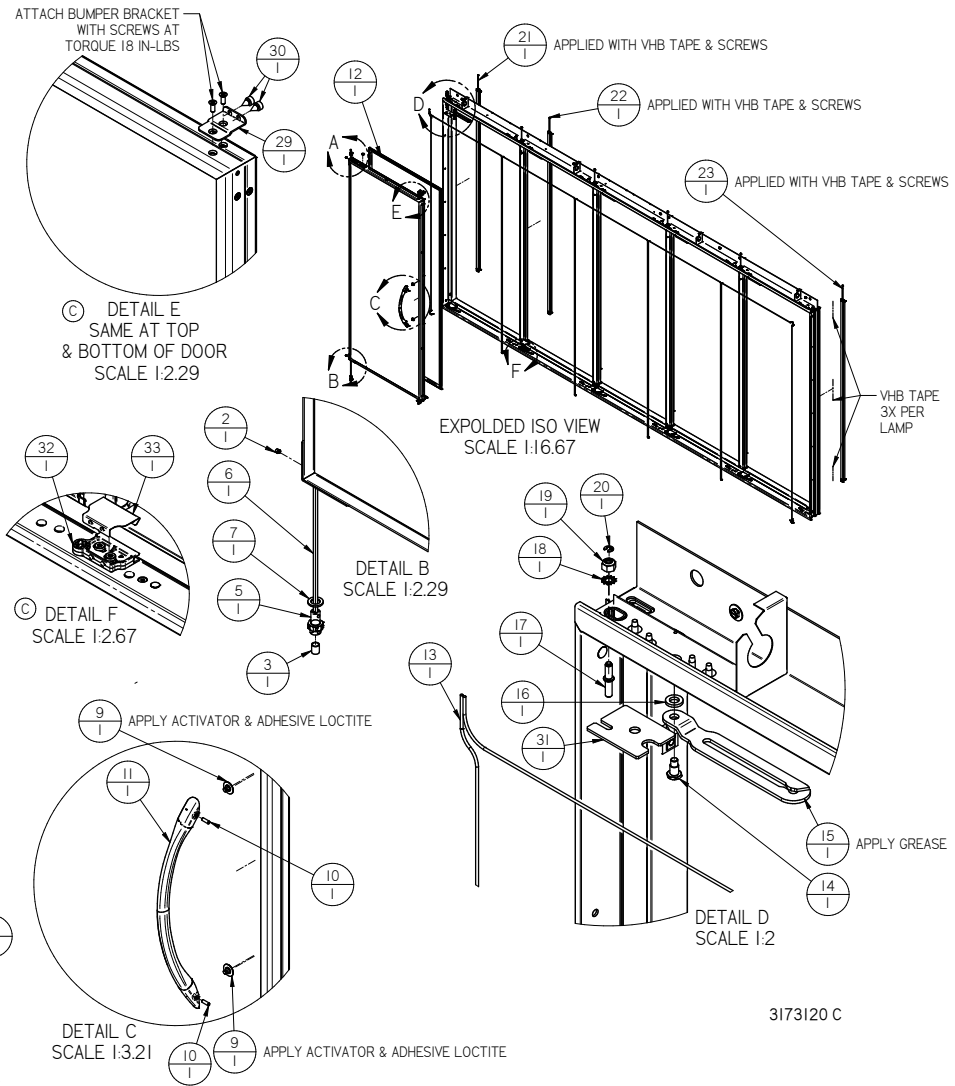
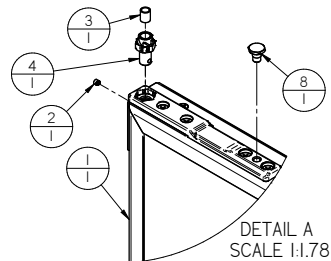

Replacement Parts List (Continued)

Part numbers and parts are subject to change.

See Warranty and Support Section of this manual for contact information.

Door handle replacement parts are shown on page 2-11.

LENGTH PART NUMBER	COLOR PART NUMBER	DESCRIPTION	QTY	HUSSMANN COLOR
	C2BIRLC022	DOOR ASSY-LH STD LTEMP 30.13 WD X 72.25 HGT BLK ECOVISION HDL	1 THRU 6 DOOR	701 BLACK
	C2GIRLC022	DOOR ASSY-LH STD LTEMP 30.13 WD X 72.25 HGT GRAY ECOVISION HDL	1 THRU 6 DOOR	101 GRAY
	C3BIRLC022	DOOR ASSY-LH ALL GL FR LTEMP 30.13 WD X 72.25 HGT BLK ECOVISION HDL	1 THRU 6 DOOR	701 BLACK
	C3GIRLC022	DOOR ASSY-LH ALL GL FR LTEMP 30.13 WD X 72.25 HGT GRAY ECOVISION HDL	1 THRU 6 DOOR	101 GRAY
	C2BIRLKO22	DOOR ASSY-RH STD LTEMP 30.13 WD X 72.25 HGT BLK ECOVISION HDL	1 THRU 6 DOOR	701 BLACK
	C2GIRLKO22	DOOR ASSY-RH STD LTEMP 30.13 WD X 72.25 HGT GRAY ECOVISION HDL	1 THRU 6 DOOR	101 GRAY
	C3BIRLKO22	DOOR ASSY-RH ALL GL FR LTEMP 30.13 WD X 72.25 HGT BLK ECOVISION HDL	1 THRU 6 DOOR	701 BLACK
	C3GIRLKO22	DOOR ASSY-RH ALL GL FR LTEMP 30.13 WD X 72.25 HGT GRAY ECOVISION HDL	1 THRU 6 DOOR	101 GRAY
	D2BIRLC002	DOOR ASSY-LH STD MDMTEMP 30.13 WD X 72.25 HGT GRAY ECOVISION HDL	1 THRU 6 DOOR	701 BLACK
	D2GIRLC002	DOOR ASSY-LH STD MDMTEMP 30.13 WD X 72.25 HGT GRAY ECOVISION HDL	1 THRU 6 DOOR	101 GRAY
	D3BIRLC002	DOOR ASSY-LH ALL GL FR MDMTEMP 30.13 WD X 72.25 HGT BLK ECOVISION HDL	1 THRU 6 DOOR	701 BLACK
	D3GIRLC002	DOOR ASSY-LH ALL GL FR MDMTEMP 30.13 WD X 72.25 HGT GRAY ECOVISION HDL	1 THRU 6 DOOR	101 GRAY
	D2BIRLK002	DOOR ASSY-RH STD MDMTEMP 30.13 WD X 72.25 HGT BLK ECOVISION HDL	1 THRU 6 DOOR	701 BLACK
	D2GIRLK002	DOOR ASSY-RH STD MDMTEMP 30.13 WD X 72.25 HGT GRAY ECOVISION HDL	1 THRU 6 DOOR	101 GRAY
	D3BIRLK002	DOOR ASSY-RH ALL GL FR MDMTEMP 30.13 WD X 72.25 HGT BLK ECOVISION HDL	1 THRU 6 DOOR	701 BLACK
	D3GIRLK002	DOOR ASSY-RH ALL GL FR MDMTEMP 30.13 WD X 72.25 HGT GRAY ECOVISION HDL	1 THRU 6 DOOR	101 GRAY
	1000001387	PIN-TORSION DOOR LH BLK	1 PER DOOR	701 BLACK
	1000001388	PIN-TORSION DOOR RH BLK	1 PER DOOR	701 BLACK
	1000001177	PIN-TORSION DOOR LH	1 PER DOOR	GRAY
	1000001178	PIN-TORSION DOOR RH	1 PER DOOR	GRAY
96640CTU00		ROD-TORSION DOOR 71.78 LG	1 PER DOOR	
	0524528	HANDLE ASM-THIN ECOVISION DOOR BLK	1 PER DOOR	701 BLACK
	0524801	HANDLE ASM-THIN ECOVISION DOOR GRY	1 PER DOOR	101 GRAY
	G7B76KCVK0	GASKET-DOOR 30.13 WD X 72.25 HGT BLK	1 PER DOOR	701 BLACK
	G7G76KCVK0	GASKET-DOOR 30.13 WD X 72.25 HGT GRAY	1 PER DOOR	101 GRAY
	0458446000	RETAINER DOOR BLACK (CAM)	1 PER DOOR	701 BLACK
	0458477000	RETAINER DOOR ZINC (CAM)	1 PER DOOR	GRAY
	3189321	BRACKET-DOOR BUMPER BLK	2 PER DOOR	701 BLACK
	3189607	BRACKET-DOOR BUMPER GRAY	2 PER DOOR	101 GRAY
	3177158	PLATE-TOP PIN RETAINER BLK	1 PER DOOR	701 BLACK
	3177159	PLATE-TOP PIN RETAINER GRAY	1 PER DOOR	101 GRAY
	3173250	PLATE-TORSION PIN BOT BLK	1 PER DOOR	701 BLACK
	3173251	PLATE-TORSION PIN BOT GRAY	1 PER DOOR	101 GRAY
	3173385	COVER-BOT TORSION PIN PLATE BLK	1 PER DOOR	701 BLACK
	3173386	COVER-BOT TORSION PIN PLATE GRAY	1 PER DOOR	101 GRAY
H2LTIRL000		HEATER-FRAME VARIABLE LTEMP IRL 2 DOOR	1 PER FRAME	
H2MTIRL000		HEATER-FRAME VARIABLE MDMTEMP IRL 2 DOOR	1 PER FRAME	
H3LTIRL000		HEATER-FRAME VARIABLE LTEMP IRL 3 DOOR	1 PER FRAME	
H3MTIRL000		HEATER-FRAME VARIABLE MDMTEMP IRL 3 DOOR	1 PER FRAME	
H4LTIRL000		HEATER-FRAME VARIABLE LTEMP IRL 4 DOOR	1 PER FRAME	
H4MTIRL000		HEATER-FRAME VARIABLE MDMTEMP IRL 4 DOOR	1 PER FRAME	
H5LTIRL000		HEATER-FRAME VARIABLE LTEMP IRL 5 DOOR	1 PER FRAME	
H5MTIRL000		HEATER-FRAME VARIABLE MED IRL 5 DOOR	1 PER FRAME	
3071876		LED-S GE LH 65IN 3500K	1 PER FRAME	
3071881		LED-S GE LH 65IN 4000K	1 PER FRAME	
3071886		LED-S GE LH 65IN 5000K	1 PER FRAME	
3071895		LED-S GE RH 65IN 3500K	1 PER FRAME	
3071900		LED-S GE RH 65IN 4000K	1 PER FRAME	
3071909		LED-S GE RH 65IN 5000K	1 PER FRAME	
3071855		LED-S GE 65IN 3500K	# OF DOORS - 1	
3071860		LED-S GE CTR 65IN 4000K	# OF DOORS - 1	
3071865		LED-S GE CTR 65IN 5000K	# OF DOORS - 1	

REMOVING DOOR(S)

Removing a door requires two people to perform this procedure safely.

1. Use an impact driver to remove the two 1/2" hex head bolts from the door cam. Once the door cam is removed from the door, the door can swing freely.
2. Remove screw (#2 Phillips) from door retaining plate. A long-bit extension is recommended for this procedure.
3. Slide out the door retaining plate (move to the right along frame).
4. Pick bottom of door up and out of door torsion plate hole.
5. Bring door down slightly in order to remove torsion pin from top of door. The door is now removed from the case.



Remove door cam from top of door(s).



Remove screw from door retaining plate

1.

2.



Remove door retaining plate.

3.



Pick door up and out of frame.

4.



Door removed from bottom of torsion plate.

5.

INSTALLING DOOR(S)

See previous page for door removal if necessary. Installing a door requires two people in order to be performed safely.

1. Locate the pin on the top of frame. Lift door and slide door torsion pin up onto frame pin.
2. Locate torsion plate hole located on bottom frame. Set bottom door torsion pin onto the torsion plate hole.
3. Use an impact driver to attach the door retaining plate (#2 Phillips).
4. Install door cam to top of door using an impact driver.
5. Set door tension using a slim box end wrench. Increase tension by turning wrench toward door handle. Stop adjustment after three audible clicks.
6. Check door closing speed. See Page 1-3 and 1-4 if further door or frame adjustments are necessary.



Slide torsion pin up and onto frame pin.

1.



Locate door onto torsion plate hole.

2.



Slide torsion pin up and onto frame pin.

3.



Install door cam at top of door.

4.



Slide torsion pin up and onto frame pin.

5.

⚠ CAUTION

- » Do not carry glass doors by the handle. Grasp each door firmly with both hands.

⚠ CAUTION

- » Do NOT remove doors from shipping crate until the doors are ready for installation.

CONVERTING LH FRAME SWING TO RH FRAME SWING OPENING:

1. Remove the hex screws to uninstall the fascia at the top of the case.
2. Remove the retaining clip, 7/16 hex locknut, and star washer from the inside of the raceway above the door opening being converted.
3. Remove the door from the opening being converted. See page 2-3.
4. Remove the pin from the LH top of the opening using a T20 Torx bit.
5. Remove the cover and bolts from the bottom torsion plate.
6. Remove plastic plugs from pin hole on top and the 2 bolt holes on bottom of RH side of opening. Insert into the same holes on the LH side for pin and torsion plate that was just removed.
7. Flip torsion plate for RH side of the opening, bolts are tightened (with impact driver) at center slot, and cover is snapped back on part.
8. Using a non-powered hand operated screwdriver with a T20 Torx bit, firmly tighten the top pin into the hole on the right side of the opening.
9. Place the star washer over the exposed threads on the pin that are sticking out above the frame.
10. While holding the pin tight with the T20 Torx hand tool, install the 7/16 hex locknut using a powered impact driver.

NOTICE

» Do not let the pin rotate when the 7/16 hex locknut is tightened.

11. Reinstall the retaining clip on the end of the threaded pin.
12. Reinstall the fascia using the hex screws at the top of the case.
13. Converting a RH to a LH swing frame opening follows similar steps with LH/RH terms swapped.

CAUTION

» Tipping Hazard! Case tipping may occur if cases are not properly leveled and secured, or if cases are not properly loaded.



1.

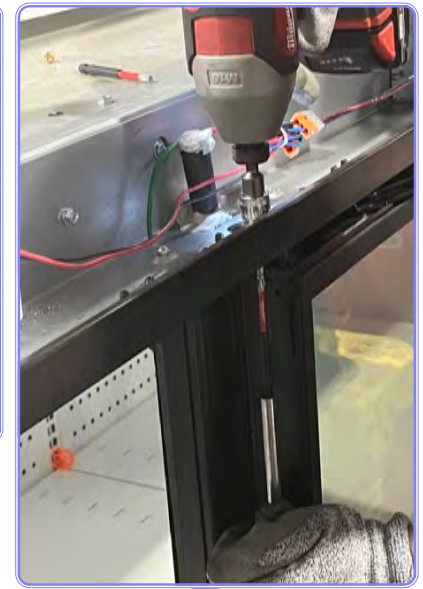

2.



4.



2.



5.

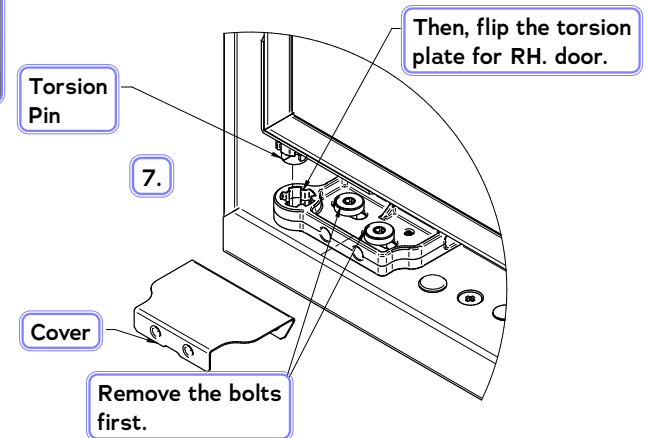

7.

Torsion Pin

Cover

Remove the bolts first.

CONVERTING A LH DOOR INTO TO A RH DOOR:

1. Remove the door and place the door on a soft, secure and flat surface. See page 2-3 for door removal.
2. Remove the 4 Phillips screws to uninstall the metal block at the top of the door.
3. Reinstall the same screws into the exposed holes on top of door.
4. Remove the 4 Phillips screws from the same locations on the bottom of the door.
5. Reinstall the block at the bottom of the door now you have a RH swing door prepared. Rotate part until it drops flush over pin.

NOTICE

» There should not be any gaps between the block and the door if installed correctly

6. Re-install the door on the case.
7. Converting a RH to a LH follows similar steps.
8. Tighten the nut on the bottom of the torsion rod toward the handle 3 clicks normally, or up to 4 clicks if needed for the door to close.



8.



2.



5.



3.

DOOR BUMPERS

There are bumpers on the top and bottom handle side of the door to increase the life of the gasket. If the bumper or bracket is damaged, it must be replaced. Proper installation of the bumper and bracket is shown below.

Door Bumper Replacement Parts:

Part Number	Item Description
1. 3189321	Bracket - Door Bumper BLK
2. 3189533	Bumper - .188 ID X .078 THK SBR Rubber Push In
3. 3189596	Instruction - Door & Frame Assy Gasket Bumper
4. 3189607	Bracket - Door Bumper Gray
5. ABZ36	Bumper - Door Gasket BLK
6. ABZ37	Bumper - Door Gasket Gray

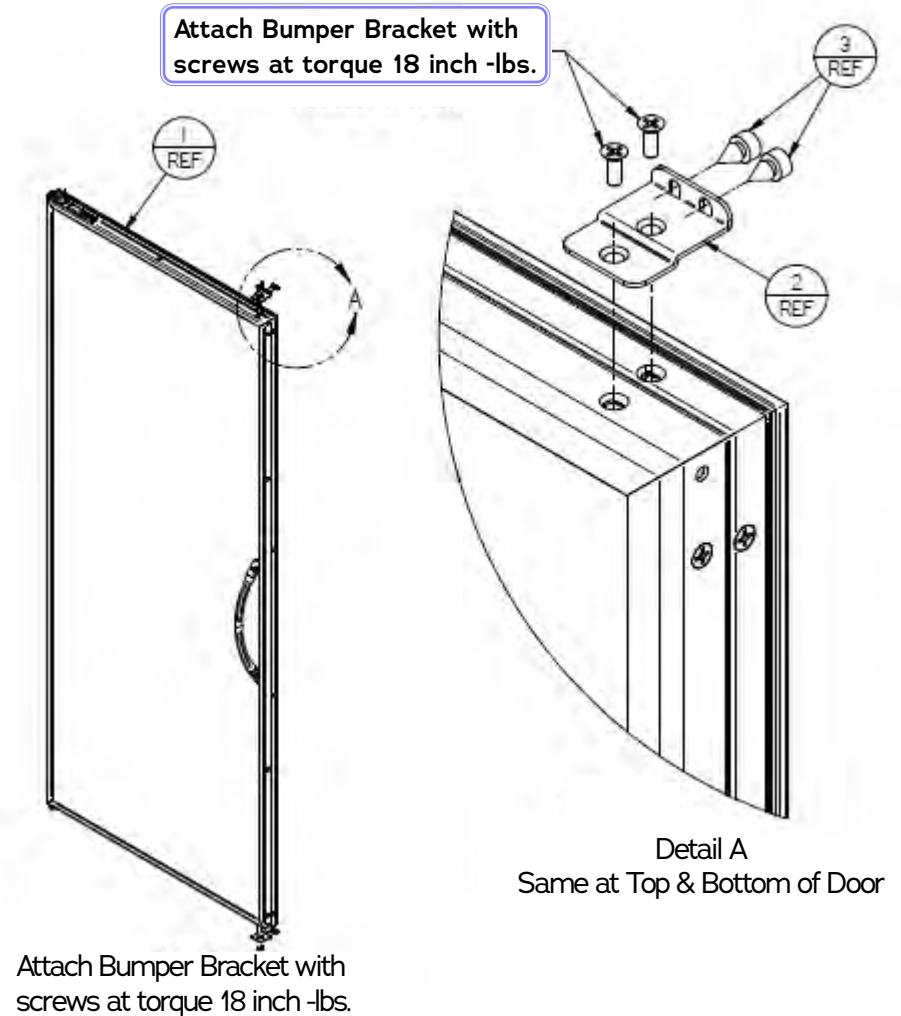

TORSION ROD REPLACEMENT FOR LH DOOR:

1. Remove the door and place the door on a soft, secure and flat surface.
2. Remove the set screw from the torsion pin located at the top of the door (requires 5/64 hex key).
3. Remove the 4 Phillips screws to uninstall the metal block at the top of the door.
4. Grip the torsion pin at the top of the door with a vice grips, and tap the vice grips away from the door with a mallet to remove the pin.
5. Grip the torsion pin at the bottom of the door and pull out the torsion rod.
6. Prepare the new rod, torsion pins, set screws, Loctite 680 retaining compound, Loctite 7649 primer, blue Loctite 242, NSF grease, and bronze washer.
7. Apply Loctite SF 7649 brush on primer to about 1" of the surface on both ends of the rod and allow the primer a few minutes to dry.



2.



3.



6.



4.



5.



7.

8. Apply 2 drops of Loctite 680 retaining compound inside the square hole on the RH torsion pin that is labeled with the letter "R".
9. Insert the bronze washer on RH torsion pin shaft, then insert the rod into the RH torsion pin.
10. Apply 1 drop of blue Loctite 242 to the set screw and tighten into the RH torsion pin using a 5/64 hex key.
11. Apply NSF NLGI #2 grade grease on the RH torsion pin outside diameter that is normally inside the door.
12. Insert the assembled RH pin and rod fully into the top of the door.
13. Reinstall the block at the top of the door using the 4 Phillips screws.
14. Apply 2 drops of Loctite 680 inside the square hole on the LH torsion pin that is labeled with the letter "L".

NOTICE

» There should not be any gaps between the block and the door if installed correctly.

15. Apply NSF NLGI #2 grade grease on the LH torsion pin outside diameter that is normally inside the door.
16. Insert the bronze washer on LH torsion pin shaft (labeled "L").
17. Insert the LH torsion pin with assembled bronze washer into the bottom of the door. There should be no gaps between the torsion pin, washer, and the door.
18. Apply 1 drop of blue Loctite 242 to the set screw.
19. Using the access hole on the side of the door, tighten the set screw into the LH torsion pin using a 5/64 hex key.
 - a. A slight rotation of the pin may be required to align the set screw with the access hole.

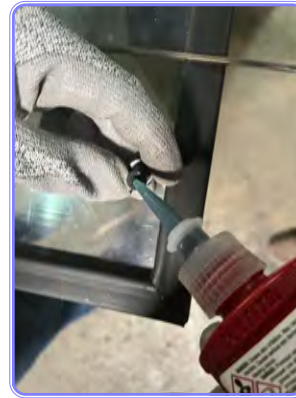

8.



9.



12. Top of door shown



15.

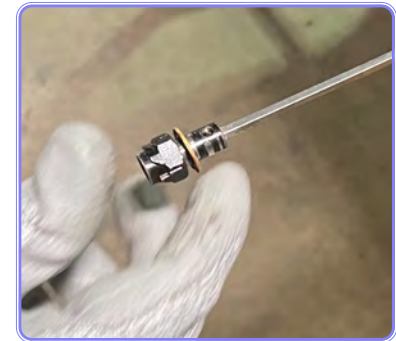

17.

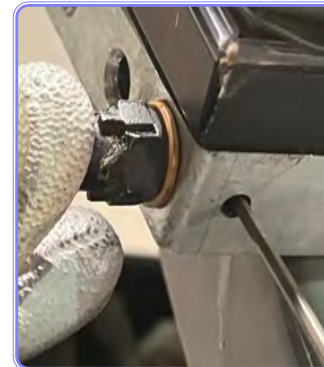

19.

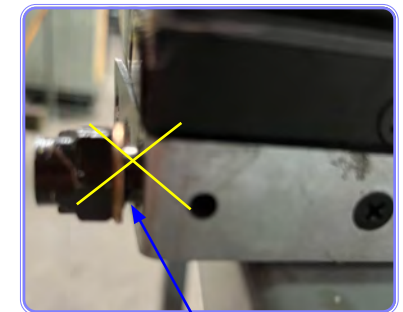

17. Gap shown. (There should be no gap).

REPLACING A DOOR CAM

1. Remove both ¼"-28 threaded shoulder bolts and the washer from the damaged CAM.
2. Place the new cam with the washer between the cam and the frame aligned with the threaded hole on the frame.
3. Using a ½" socket and impact driver, tighten the long bolt into the hole on the cam and onto the frame.
4. Using a ½" socket and impact driver, tighten the short bolt into the slot on the cam and onto the door.
5. Apply NSF NLGI #2 grease on the teeth at the end of the slot on the cam. Reinstall door. Open and close the door to check for full coverage of the grease.

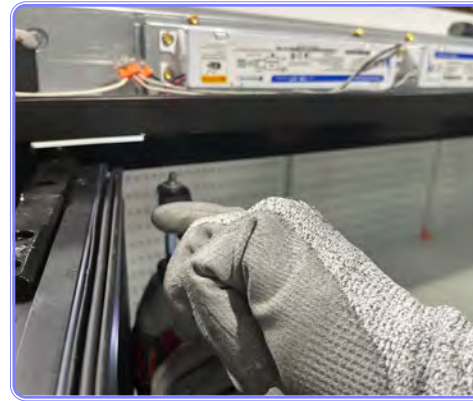

3.



4.



2.

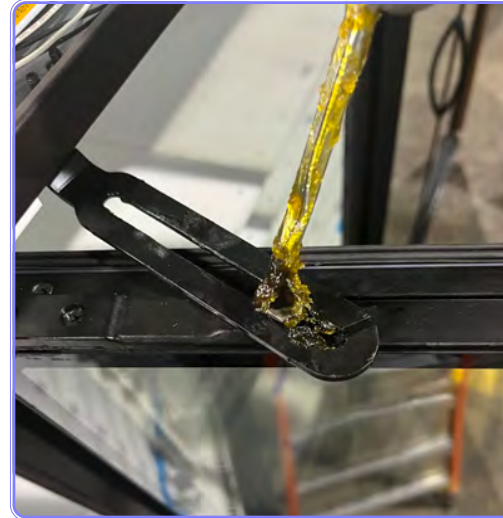

5.



5.

REPLACING DOOR HANDLE(S)

These doors have glued on studs. If the handle is broken it should be replaced along with the stud.

1. Use a razor blade to remove the excess glue from the door. Only replace the stud that is damaged.
2. Clean the glass surface. Apply isopropyl alcohol to the surface of the glass and wipe using a paper towel until dry.
3. Clean the surface of the stud. Apply isopropyl alcohol to the surface to the stud and wipe using a paper towel until dry.
4. Apply Loctite SF 7387 to the bottom flat surface of the stud and wait 30 seconds or until dry.



1.



2. & 3.

Replacement Parts

Kit	Description	Components in Kit	Order
ABB91	Retrofit studs only	2 studs only, 2 sets screws, instructions	Replace 1 or 2 studs only - have original handle
ABB92	Retrofit black handles and studs	2 studs, one black handle assembly, 2 set screws	Replace black handle, 2 studs, 2 set screws
ABB93	Retrofit black handles and studs	2 studs, one gray handle assy, 2 set screws	Replace gray handle, 2 studs, 2 set screws
ABB94	Glue and Template	adhesives and template	Template and adhesives for repairing many handles

Tools and Supplies Needed:

- EcoVision Stud: P/N 3119359
- Glue: Loctite AA 392
- Activator: Loctite SF 7387
- Razor
- Hammer, if needed
- Template
- Isopropyl Alcohol
- Paper Towels
- Tape



4.

5. Place the stud template in the correct orientation/location and secure to surface of the door.

Ensure tape does not leave residue when removed. Painter's tape and 3M 8898 are the suggested choice of tape to use.

6. Apply a drop of Loctite AA 392 to the center of the stud.

7. By hand, firmly press the stud to the glass for 15 seconds.



5.



6.

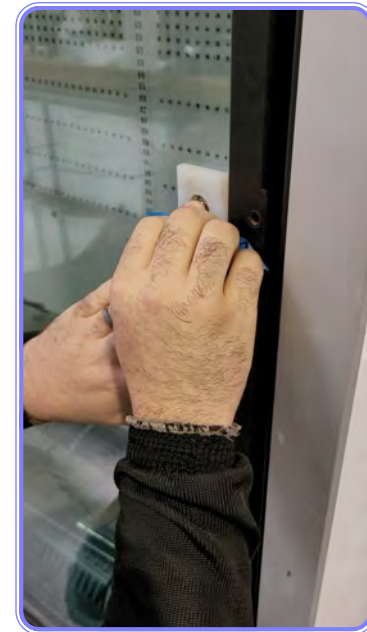

7.

8. Carefully remove the stud template from the door. Wait about 5 minutes to allow the glue to cure fully.
9. Carefully wipe away any excess glue / activator from glass surface and clean using isopropyl alcohol.



8.

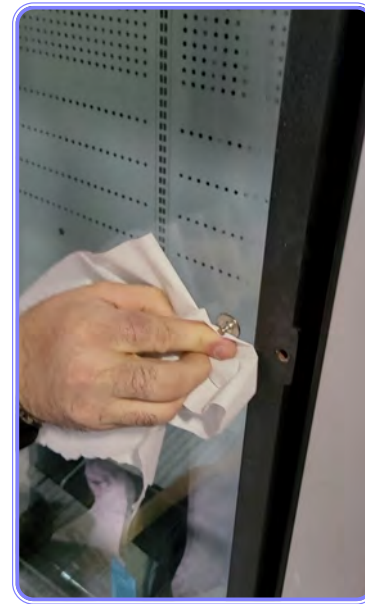

9.



9.

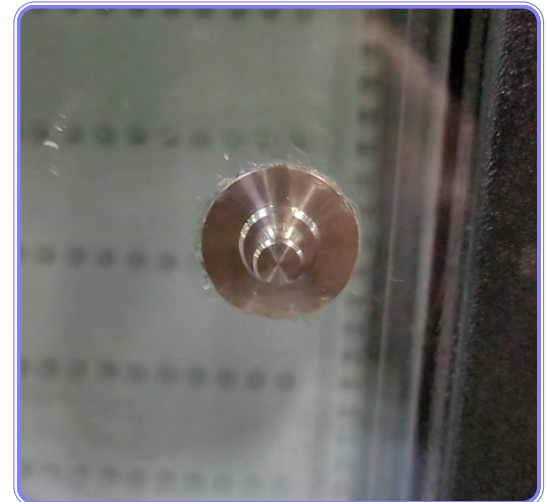

9.

REPLACING LED LIGHTING

(Center & End Door Mullions)

NOTE:

LED lamps must be replaced with like parts. Contact your Hussmann representative to order replacements. See additional details on the next three pages.

1. Remove product from case and store at appropriate temperature.
2. Turn off light switch.
3. Remove existing screws and pry the old LED bar off the frame with a flathead screwdriver. There is tape located on the top, bottom, and center of the LED bar that must be removed from the frame. There is one screw location at the top and one at the bottom of the LED bar.
4. Cut the wire from the mullion lighting harness. Cut the LED wires to about 3 inches. Strip wires to about 3/8 inches.
5. Reconnect wiring with new connectors for the new LED bar. Be sure to crimp connection using crimping pliers. Wire nuts are also acceptable to use. Hide wiring so that no wires are exposed. Verify circuit against appropriate wiring diagram.

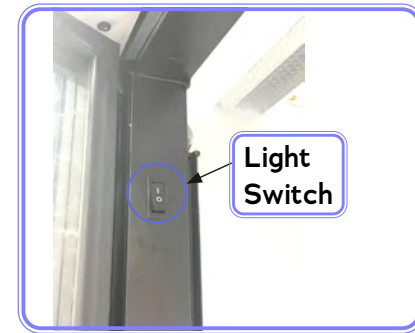

2.

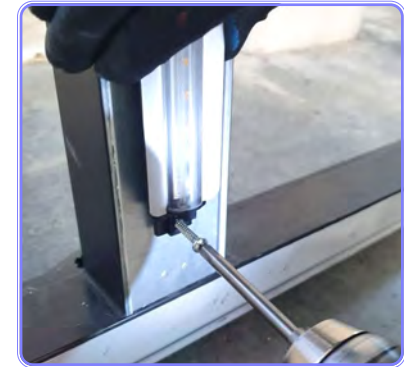

3.

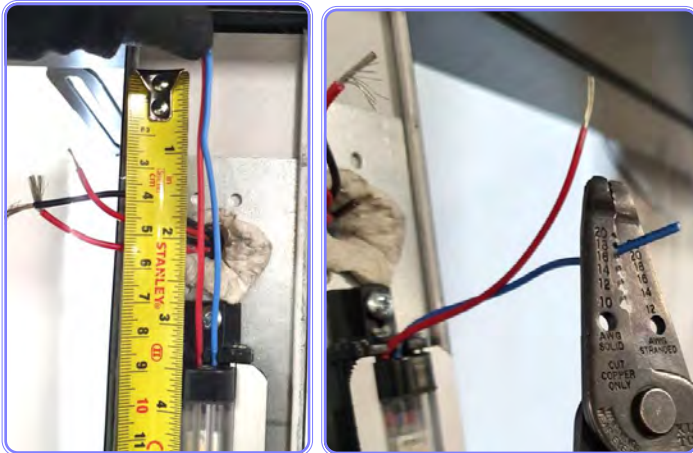

4.

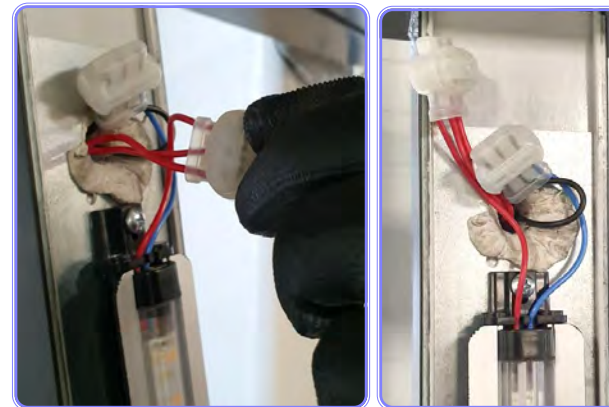

5.

REPLACING LEDS (CONTINUED)

(Center & End Door Mullions)

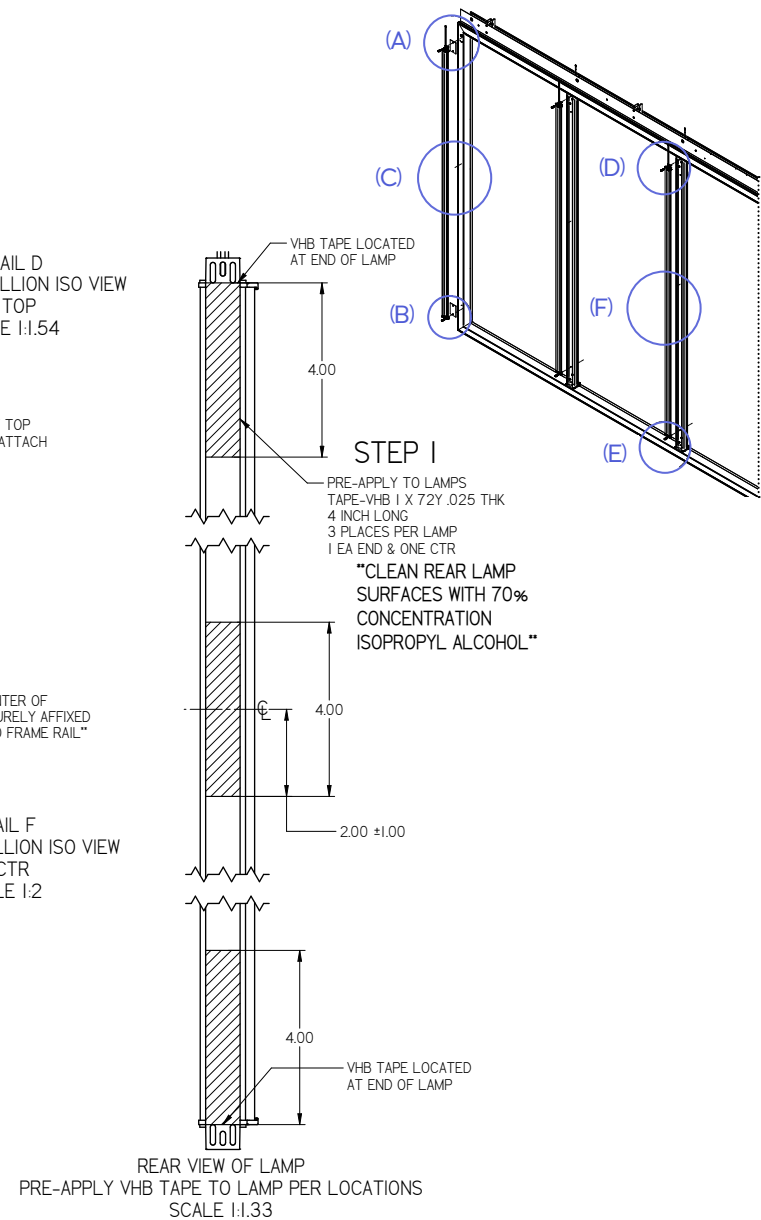
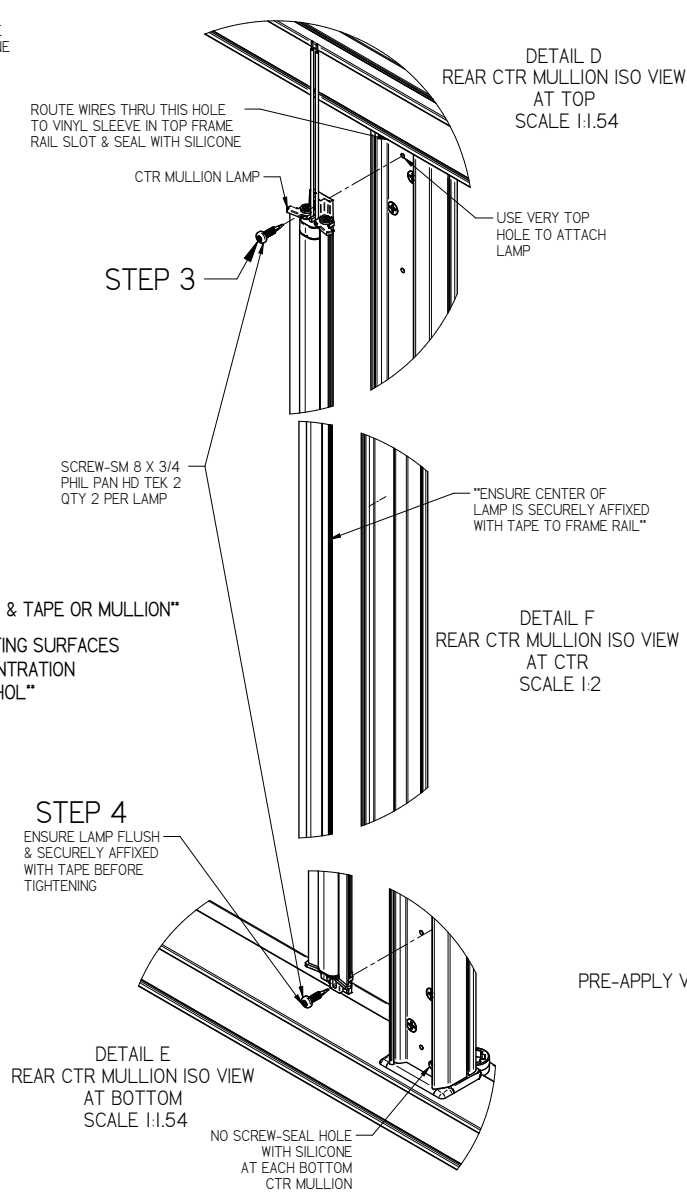
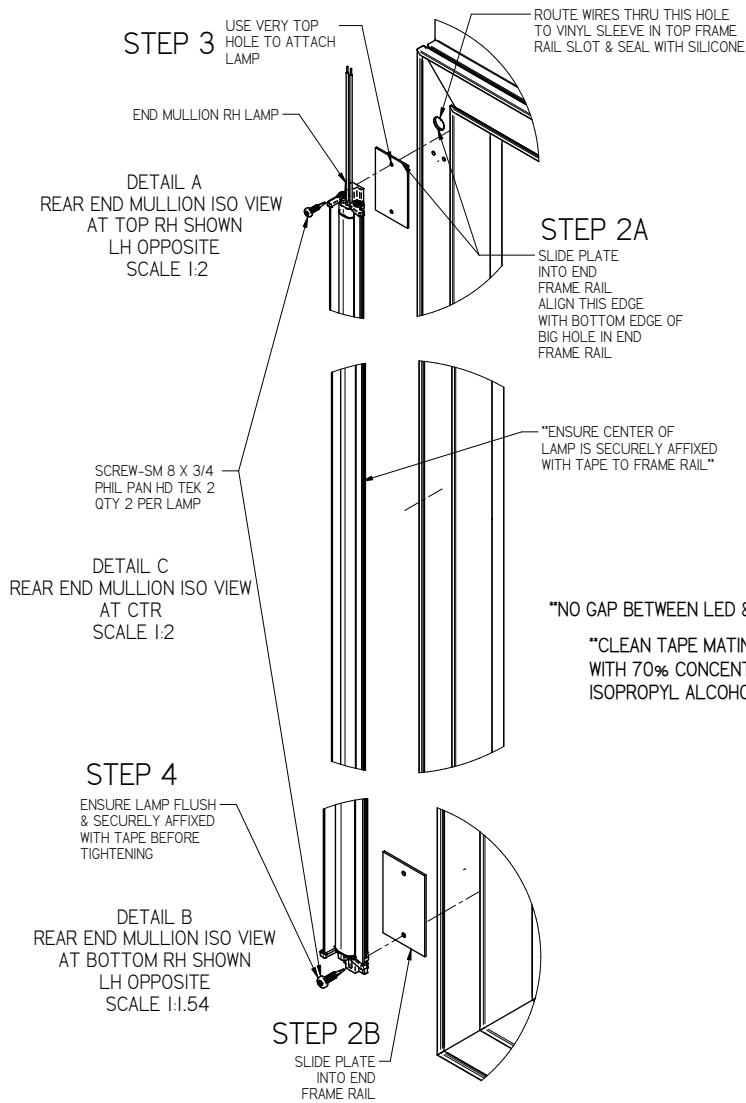

REPLACING LEDs (Continued) (Center & End Door Mullions)

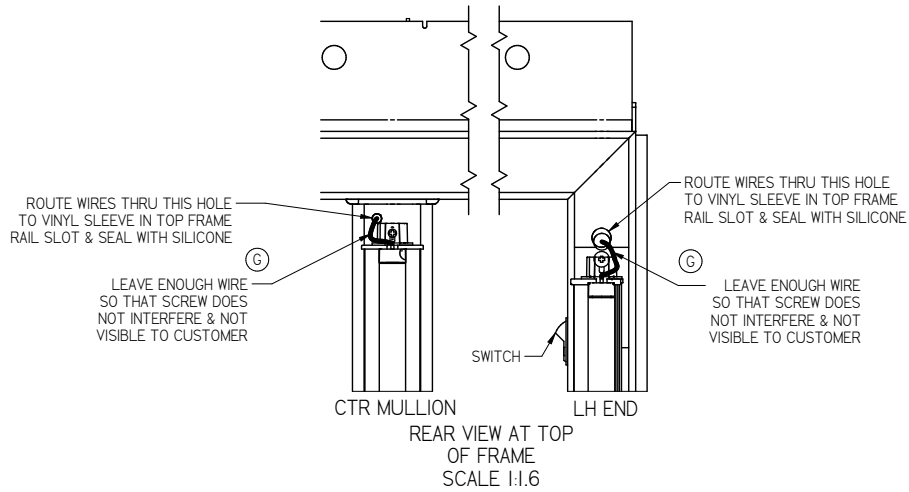

SLOT WITH VINYL SLEEVE IN FRAME & RACEWAY- SILICONE APPLIED INSIDE VINYL SLEEVE BOTH ENDS

WIRES ROUTE THRU VINYL SLEEVE IN SLOT IN FRAME & RACEWAY- SEAL BOTH ENDS WITH SILICONE

FRONT OF FRAME

TOP VIEW OF LH & RH LED LAMP ORIENTATION SCALE 1.06:1

SLOT WITH VINYL SLEEVE IN FRAME & RACEWAY- SILICONE APPLIED INSIDE VINYL SLEEVE BOTH ENDS

FRONT ISO VIEW AT TOP OF FRAME SCALE 1:2.67

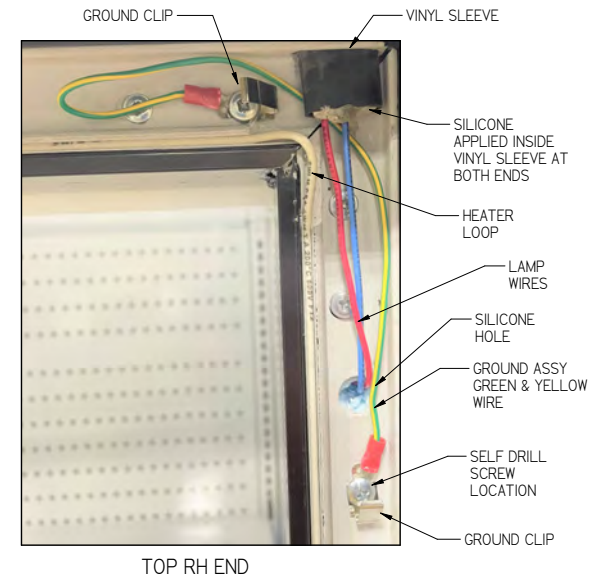
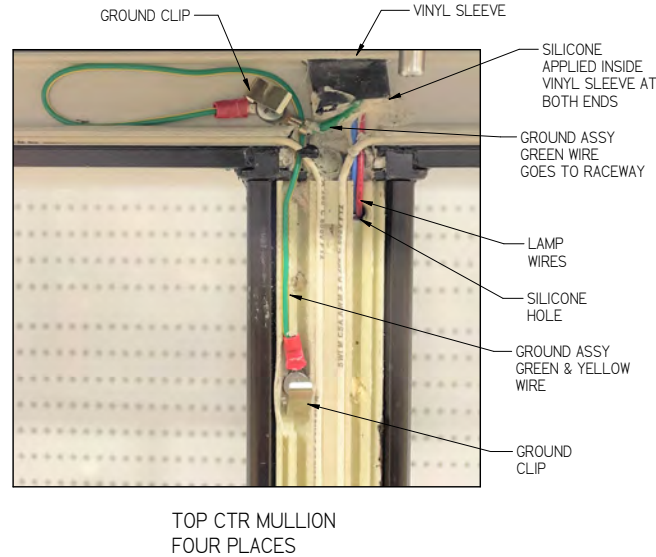
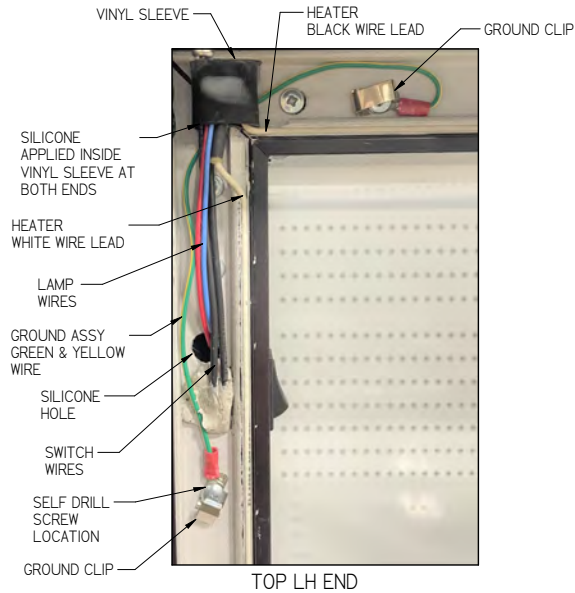

REPLACING LEDs (Continued)
 (Center & End Door Mullions)

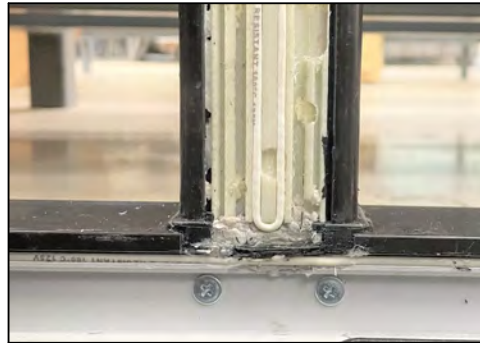
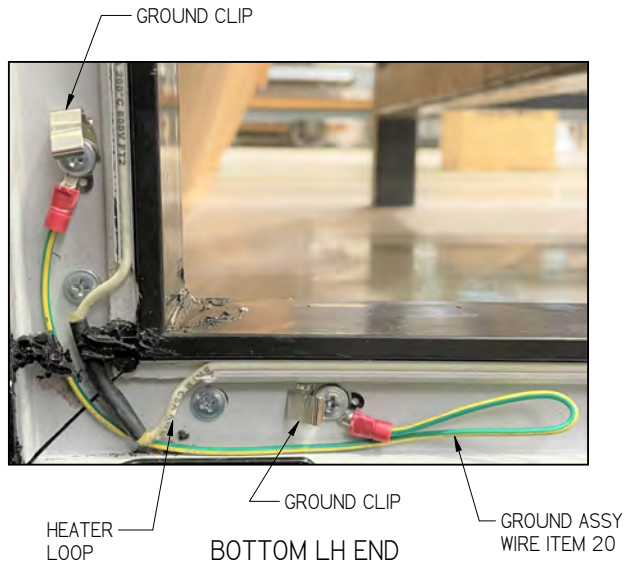

NO GROUND WIRE VIEW
 2-4 DOOR NO GROUND WIRE
 **5 DOOR ONLY HAS
 BOTTOM FIRST & FOURTH
 CTR MULLION FROM LH END
 WITH NO GROUND WIRE**

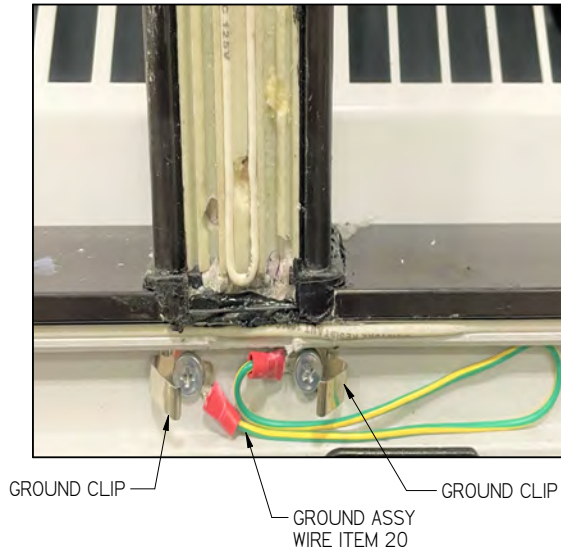

5 DOOR ONLY
 BOTTOM SECOND & THIRD CTR MULLION FROM LH END

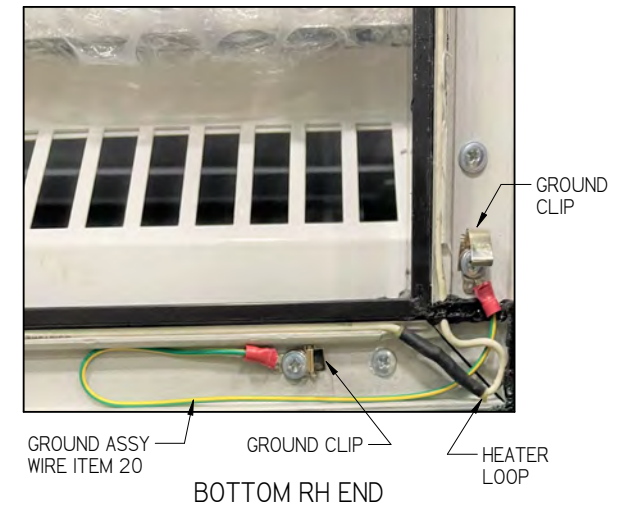

REPLACING POWER SUPPLY(S)

LED Power supply(s) for canopy lights are located at the top of the merchandiser inside the canopy.

1. Disconnect power from the merchandiser.
2. Remove canopy screws to access power supply(s).
3. Replace power supply(s).
4. Reconnect the electrical power.
5. Check to make sure LED mullion lights are working properly.

See case manual for case wiring diagrams.

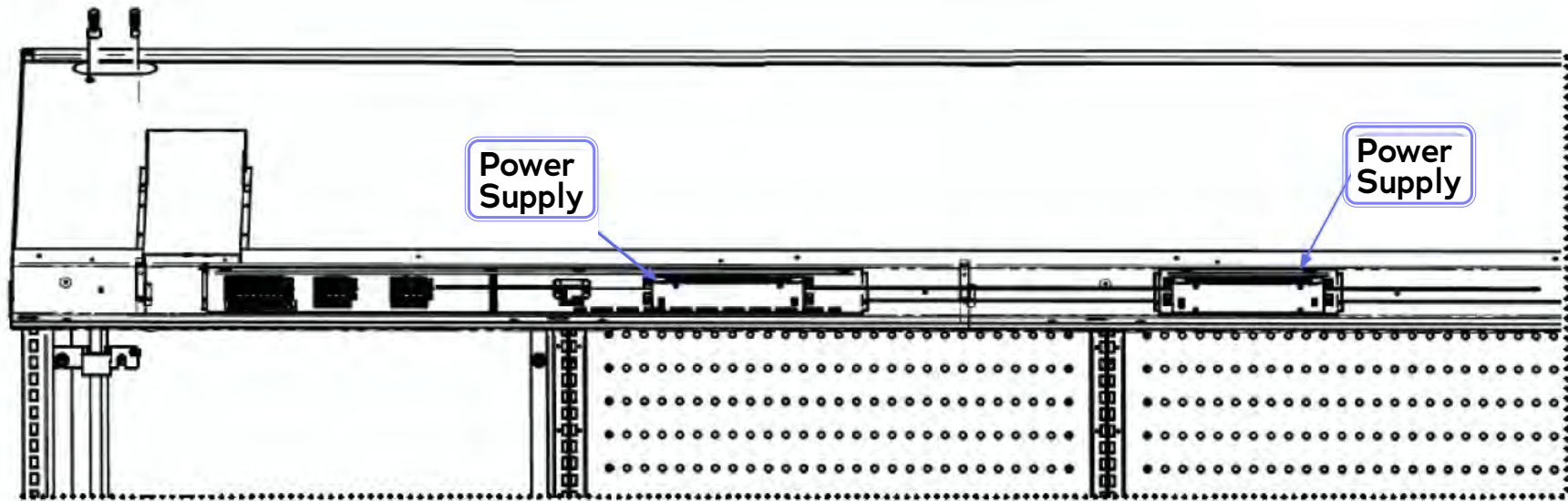
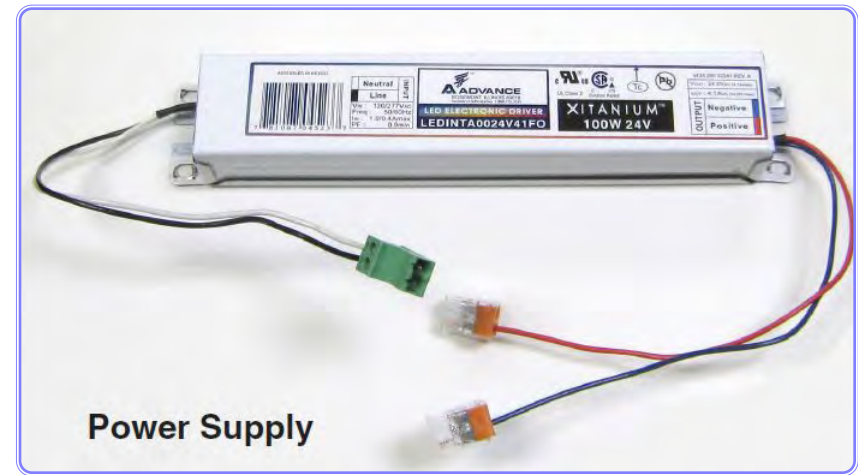

REPLACING MAGNETIC GASKET

Carefully remove the old gasket from the groove in the back of the door as shown below.

The new gasket will be easier to work with if it is at ambient temperature. Begin by lubricating the new gasket with a mild soap and water solution.

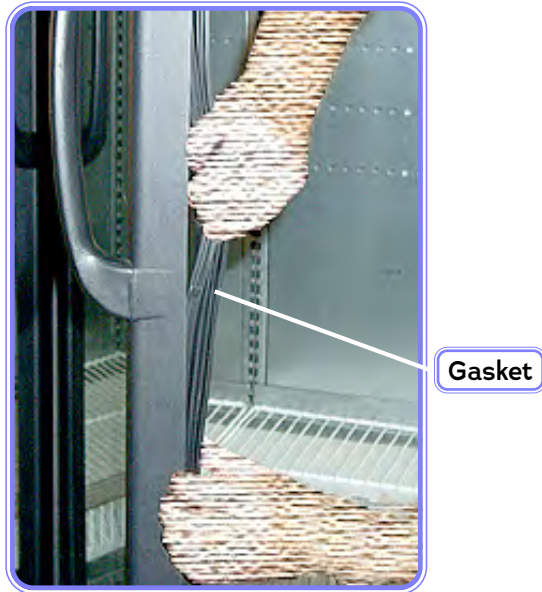

Work from the corners to the centers of each side, top, and bottom. Carefully push the new gasket into the groove at each corner. Refer to (A). Then, press the gasket into the channel at the center of the top, bottom, and each side (B). Avoid stretching the gasket.

Sub-divide remaining areas and push the gasket in at those points (C).

Sub-divide once again and repeat pushing the gasket in until all of the gasket is evenly seated in the groove (D).

Use a soft cloth or paper towel to dry the gasket before closing the door on the clean door frame.

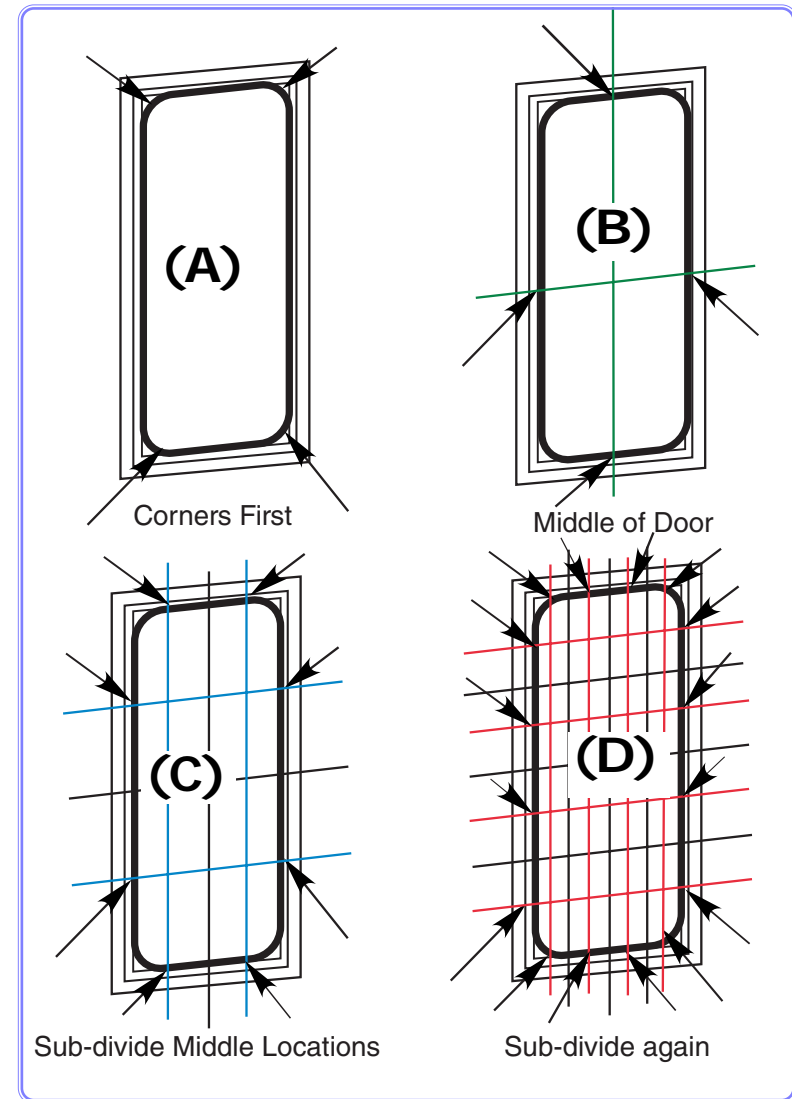

Sequence for Installing New Gasket

RESTORING GASKET SEAL

Occasionally, a crimped or damaged gasket can cause gaps in the seal, leading to frost formation on the doors. Use this procedure to close gaps and end frost formation on doors.



Improperly installed or damaged gasket

Locate Gaps

Typically, interior case lighting will provide enough light to see gaps. In some cases, the only way to see gaps is to provide a backlight, as shown in (A). Backlight the door mullion and look for places the light shines between the door and gasket (B).

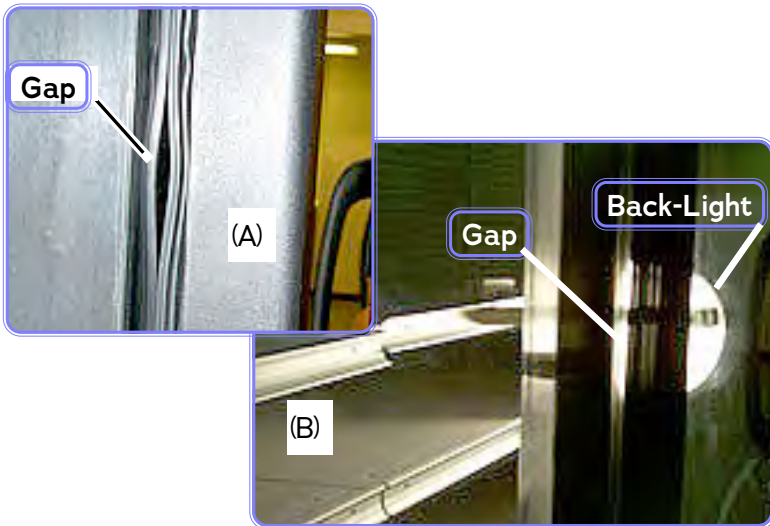

Back-Lighting Gaps in Gasket

Heat the Gasket

Make sure the door is closed. Beginning at the top of the gap, use a heat gun or electric hair dryer (1500-1600 watt) to heat the gasket with a constant up and down motion.

NOTE:

If a gap runs the entire length of the door, heat the area 4 inches (100 mm) above and 8 inches (200 mm) below the top-most point where the gap starts and work in 12-inch (300 mm) increments.

If the gasket becomes shiny, remove heat immediately as this is an indication that the gasket is near the melting point.

If possible, direct the hot air onto the gasket and also through the gap between the gasket and mullion. This will help to heat both sides of the gasket. Refer to (A) and (B) below.

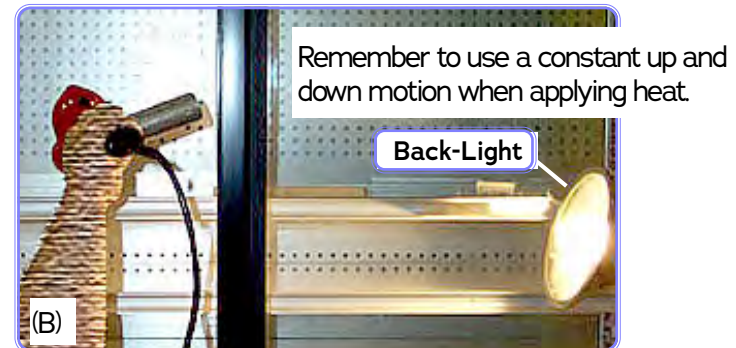
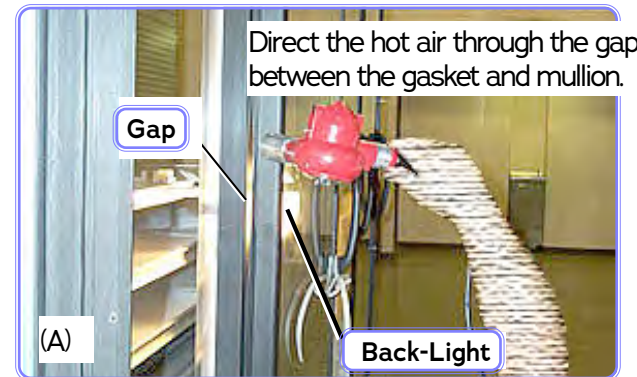

Applying Heat to Gasket

As the gasket softens and becomes pliable, the magnet in the gasket should pull it across the gap. As the gap closes, move heat down to create a zippering effect as shown below.

If the gasket is not pulled across the gap by the magnet, reach around the mullion (from the inside) and pull the gasket skirt toward the mullion.

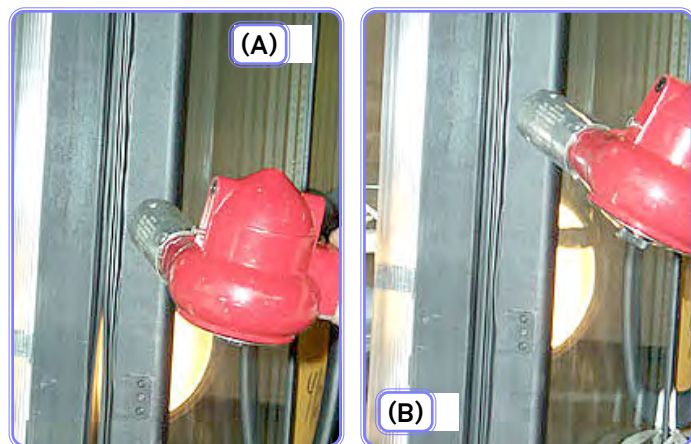

Zipper Effect

This can also be accomplished by pushing the magnet across the gap from the outside with a pencil or other non-heat conducting material.

On doors where the gap is against an end, top, or bottom mullion, this process can still be done; however, the heat will need to be directed between the lip of the mullion and the edge of the door. It will work in the same fashion but the back-light shining through and showing on the mullion will have to be a guide as to the position of the gasket.

Cool the Gasket

Once the gap is closed, remove the heat and allow the gasket to cool, undisturbed, for 3 to 5 minutes. As the gasket cools, it will set permanently in this new shape. Once the gasket is cool to the touch, open the and close the door. Verify that the gasket seals. If not, repeat the process. If the gasket rolls it must be replaced.

Use a soft cloth or paper towels, and a mild soap and water solution to thoroughly clean the gasket. Dry the gasket completely with a fresh cloth or paper towels before closing the door on a clean door frame.



Pulling Gasket Into Place With a Pencil

CLEANING ANTI-FOG GLASS DOORS

Wipe inside of anti-fog glass doors with isopropyl alcohol and a microfiber cloth. Only use a terry weave micro-fiber cloth. Allow surface to dry before closing door. Use of other cleaners or abrasives may damage the surface, and/or void the warranty. Ensure protective shipping film is removed from the doors. The film was applied only for use in shipping.

- **Never use abrasive or highly alkaline cleaner on door film.**
- **Never use aromatic or halogenated solvents like toluene, benzene, gasoline, acetone or carbon tetrachloride on door film.**
- **Use of incompatible cleaning materials with door film can cause surface damage.**
- **Contact with aggressive solvents and chemicals such as methyl ethyl ketone (MEK) or hydrochloric acid can result in surface degradation and possible crazing of door film.**
- **Never scrub with brushes, steel wool or other abrasive materials.**
- **Never use squeegees, razorblades or other sharp instruments to remove deposits or spots.**
- **For all mentioned chemicals consult the manufacturer's material safety datasheet (MSDS) for proper safety precautions.**

Selection of cleaning products suitable for use with Clarifoil® AF1000 Film

Product	Ingredients
Water	
Water and Washing up Liquid	Anionic Surfactant, 2-bromo-2-nitropropane, Methylchloroisoethiazoline, Methylisothiazolinone
Windolene	Butoxypropanol, Methoxyisopropanol, Propylene Glycol, Alkyl Polyglucoside, Acetic Acid, Sodium Laureth Sulfate, Sodium Lauryl Sulfate, Colorant
Mr. Muscle	Butoxypropanol, Propylene Glycol, 2-Hexyloxyethanol, Acetic Acid, Lactic Acid, Sodium Alkyl Sec Sulfonate, Sodium Dodecylbenzenesulfonate, Sodium Xylene Sulfonate
Walmart own	Benisothiazolinone, Methylisothiazoline, Methylchloroisoethiazoline, Methylisothiazolinone
Glass wipes	DMDM Hydantoin, Formaldehyde
Windex products	Any of: Water, 2-hexoxyethanol, isopropanolamine, sodium dodecylbenzene sulfonate, lauramine oxide, ammonium hydroxide, sodium hydroxide, alkyl polyglycoside, propylene glycol, butoxypropanol, acetic acid, sodium c1417 sec-alkyl-sulfonate, lactic acid,

Cleaning products containing acetone should NOT be used on or in close proximity to Clarifoil® film.

WARRANTY & SUPPORT

HUSSMANN®

To obtain warranty information or other support, contact your Hussmann representative or visit: <https://www.hussmann.com/services/warranty>. Please include the model and serial number of the product.

For questions about your equipment please contact our Technical Support Team 866-785-8499

For General Support or Service Calls contact our Customer Support Call Center 800-922-1919

For ordering Aftermarket Warranty Parts 1-855-Huss-Prt (1-855-487-7778) Hussmann_part_warranty@hussmann.com