



Model shown with options.

---

## B4X-E

Excel High Volume, Four-Deck  
Bulk Convertible Merchandiser

# Hussmann Excel High Volume, Four-Deck Bulk Convertible Merchandiser for Cheese, Deli, Grab and Go, and Produce Applications

## B4X-E - High Volume, Four-Deck

Available in 8' and 12' lengths. Contact your sales rep for information on possible availability of additional case lengths.

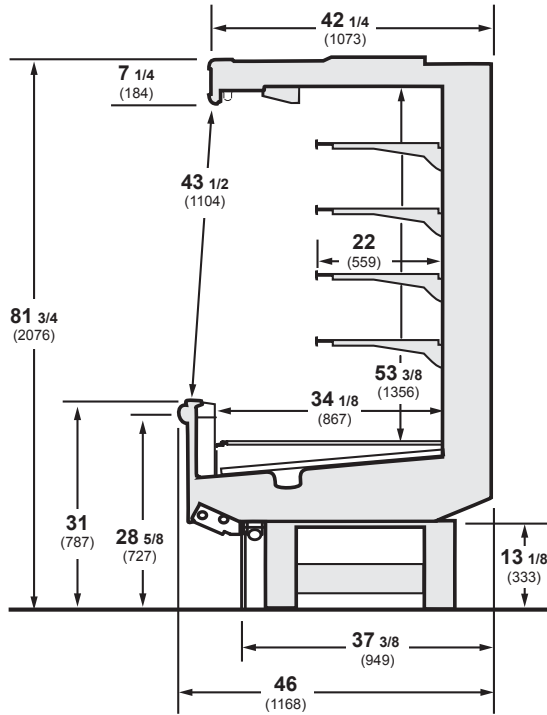

## Plan View

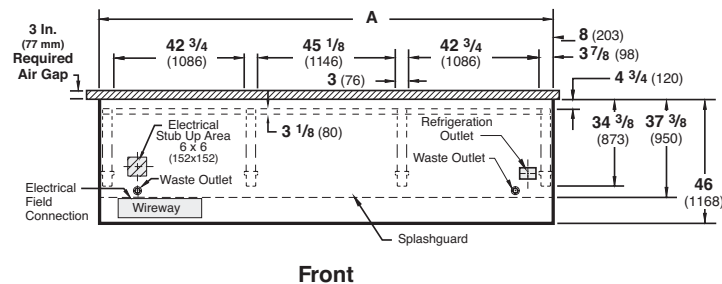

Dimensions	8 FT	12 FT
A	96 3/8 (2448)	144 1/2 (3670)

### Notes:

Case-to-case electrical connections are made in front of splashguard.

Overall case length without ends or partitions. Contact your sales representative for information on possible availability of additional case lengths.

### Note

Use Hussmann's technical data sheets to get precise dimensions for all store layout purposes.

## Extended Depth for Bulk Applications.

The B4X-E high-volume multi-deck is the newest case in Hussmann's bulk line-up. With four decks and an 82-inch height, the B4X-E can hold four layers of product for easy shopping in higher volume departments. It is 4-inch deeper (front to back) than our standard Excel multi-deck fixtures for maximum pack-out of bulk medium temp items. Interior merchandising space is 34-1/8" deep (front to back at lower deck) by 53-3/8" tall.

## Improved Lighting.

EcoShine II LED lights are now available on the B4X-E. The new LEDs provide bright, even illumination of products with lower energy costs.

## Longer Shelf Life.

Modular coils and off-time defrost work to reduce thermal shock and stabilize product temperatures.

## Lower Labor Costs.

Labor-saving features include greater clearance under the case, easy-to-clean bathtub bottom with no coil in the bottom of the case, easier raceway access, 2-ft honeycomb sections and more.

## Superior Reliability.

Our five-year modular coil warranty is the best available. Pre-set adjustable expansion valves are designed to hold optimal temperatures.



Hussmann refrigerated merchandisers configured for sale for use in the United States meet or surpass the requirements of the DOE 2017 energy efficiency standards.

NOTE: These merchandisers are designed for use in stores when temperature and humidity do not exceed 75°F and 55% R.H.

NOTE: We reserve the right to change or revise specifications and product design in connection with any feature of our products. Such changes do not entitle the buyer to corresponding changes, improvements, additions, or replacements for equipment previously sold or shipped.

For additional resources, contact your representative or visit [www.hussmann.com](http://www.hussmann.com).

**HUSSMANN**

Hussmann Corporation  
12999 St. Charles Rock Rd.  
Bridgeton, MO 63044-2483  
Ph: 314.291.2000

[www.hussmann.com](http://www.hussmann.com)