



C2NX-XLP, C2NX-XLGP

Excel Extra Height, Narrow Footprint,
Multi-Deck Convertible Merchandisers
for All Medium Temperature Applications

Husmann Excel Extra Height, Narrow Footprint Multi-Deck Convertible Merchandisers for All Medium Temperature Applications

C2NX-XLP - Convertible, Narrow Footprint, Extra 55" Height, Low Front, High Efficiency Plus Coil
C2NX-XLGP - Convertible, Narrow Footprint, Extra 55" Height, Low Front with Glass

Available in 8' and 12' lengths. Contact your sales rep for information on possible availability of additional case lengths.

C2NX-XLP

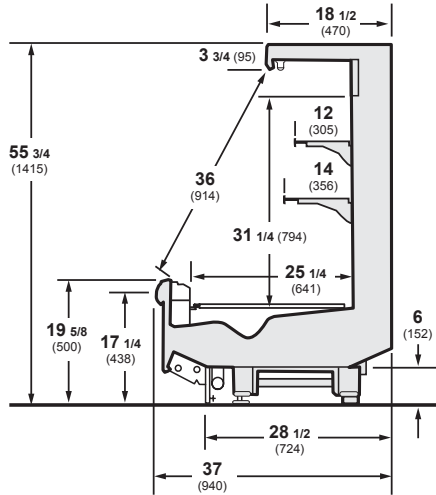

C2NX-XLGP

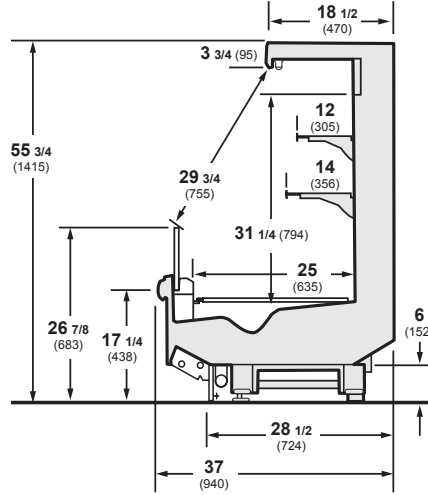

Plan View

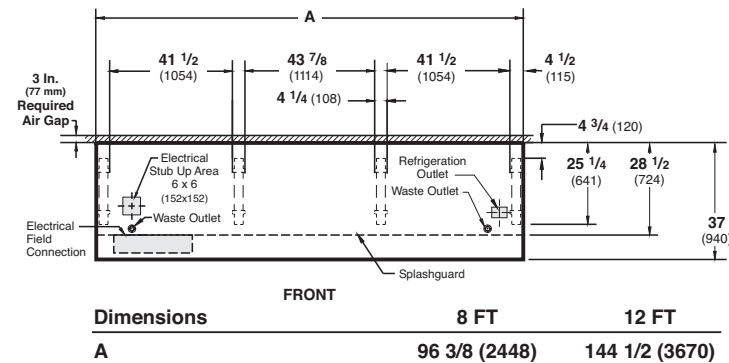

Notes:

Case-to-case electrical connections are made in front of splashguard.

Overall case length without ends or partitions.

Note

Use Husmann's technical data sheets to get precise dimensions for all store layout purposes.

Superior Merchandising

The C2NX-XLP is 55-3/4" tall to accommodate up to 4-display levels. The narrow footprint saves floorspace. The XLGP model has a glass front. Both models have a higher efficiency coil. All models provide quick, easy shopping access and merchandise a wide variety of refrigerated foods. Ideal for grab-n-go meals or other high margin prepared food selections.

Superior Shelf Life

Modular coils and off-time defrost work to reduce thermal shock and stabilize product temperatures, resulting in better freshness and longer shelf life. Modular defrost (optional) can further stabilize temperatures.

Lower Labor Costs

Labor saving features include greater clearance under the case, easy-to-clean bathtub bottom with no coil in the bottom of the case, easier raceway access, 2-ft honeycomb sections and more.

Superior Reliability

Our 5 year modular coil warranty is the best available. Pre-set adjustable expansion valves are designed to hold optimal temperatures.



Husmann refrigerated merchandisers configured for sale for use in the United States meet or surpass the requirements of the DOE 2017 energy efficiency standards.

NOTE: These merchandisers are designed for use in stores when temperature and humidity do not exceed 75°F and 55% R.H.

NOTE: We reserve the right to change or revise specifications and product design in connection with any feature of our products. Such changes do not entitle the buyer to corresponding changes, improvements, additions, or replacements for equipment previously sold or shipped.

For additional resources, contact your representative or visit www.husmann.com.



Husmann Corporation
 12999 St. Charles Rock Rd.
 Bridgeton, MO 63044-2483
 Ph: 314.291.2000

www.husmann.com