



---

# C2XEC-XEP

Excel Medium Temp Convertible Merchandiser  
with Extended Canopy and Extra Height

# Husmann Excel Medium Temp Convertible Merchandiser with Extended Canopy and Extra Height

## C2XEC-XEP - Convertible, 2-Decks, Extended Canopy, Extra Height, E Plus Coil

Available in 8' and 12' lengths. Contact your sales rep for information on possible availability of additional case lengths.

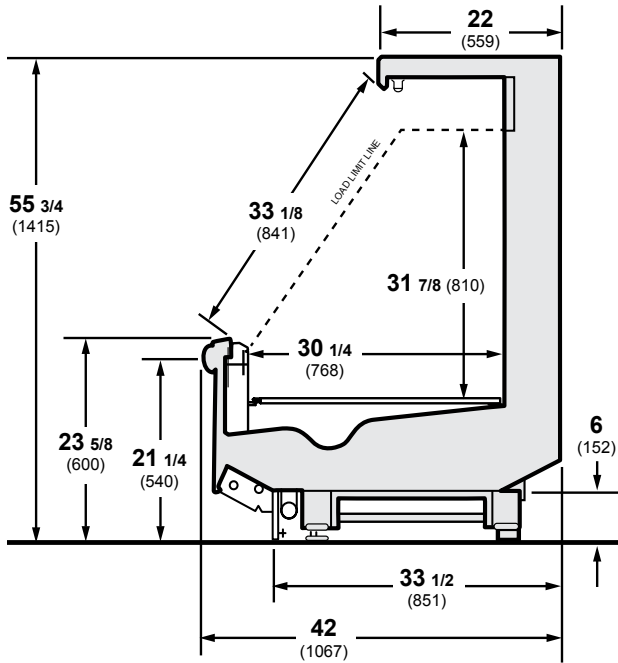

## Plan View

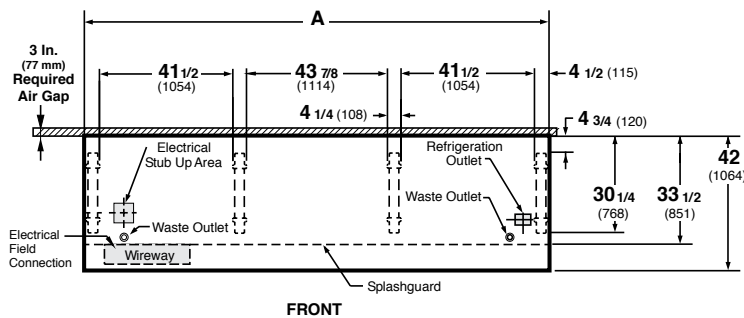

Dimensions	8 FT	12 FT
A	96 3/8 (2448)	144 1/2 (3670)

**Notes:**  
Case-to-case electrical connections are made in front of splashguard.  
Overall case length without ends or partitions.

## Note

Use Husmann's technical data sheets to get precise dimensions for all store layout purposes.

## Superior Merchandising.

The C2XEC-XEP is a medium capacity, high performance convertible merchandiser. Shelves can be placed in any position due to the recessed shelf wiring harness channel in Excel. The C2XEC-XEP does an excellent job with any medium temperature product, including dairy, deli, pre-cut, and packaged produce.

## Lower Energy Costs.

E Plus high efficiency coils keep energy costs down. Integrated night curtains are optionally available to further reduce energy costs.

## Superior Shelf Life.

Modular coils and off-time defrost help reduce thermal shock and stabilize product temperatures.

## Lower Labor Costs.

Labor saving features include easier access for cleaning under the case, easy-to-clean bathtub bottom (no coil in the bottom of the case) and simplified raceway access for quicker installation, and more.

## Superior Reliability.

Our five-year modular coil warranty is the best available. Pre-set adjustable expansion valves are designed to hold optimal temperatures.

**DOE 2017 Energy Efficiency Compliant** Husmann refrigerated merchandisers configured for sale for use in the United States meet or surpass the requirements of the DOE 2017 energy efficiency standards.

NOTE: These merchandisers are designed for use in stores when temperature and humidity do not exceed 75°F and 55% R.H.

NOTE: We reserve the right to change or revise specifications and product design in connection with any feature of our products. Such changes do not entitle the buyer to corresponding changes, improvements, additions, or replacements for equipment previously sold or shipped.

For additional resources, contact your representative or visit [www.husmann.com](http://www.husmann.com).

**HUSMANN®**

Husmann Corporation  
12999 St. Charles Rock Rd.  
Bridgeton, MO 63044-2483  
Ph: 314.291.2000

[www.husmann.com](http://www.husmann.com)