



C2XSC-LP, C2XSC-LG

Excel Low Profile, Short Canopy,
Low Front, Multi-Deck Convertible Merchandiser
for All Medium Temperature Applications

Husmann Excel Low Profile, Short Canopy, Low Front, Multi-Deck Convertible Merchandiser for All Medium Temperature Applications

C2XSC-LP - Convertible, Low Profile, Short Canopy, Low Front
C2XSC-LG - Convertible, Low Profile, Short Canopy, Low Front with Glass

Available in 8' and 12' lengths. Contact your sales rep for information on possible availability of additional case lengths.

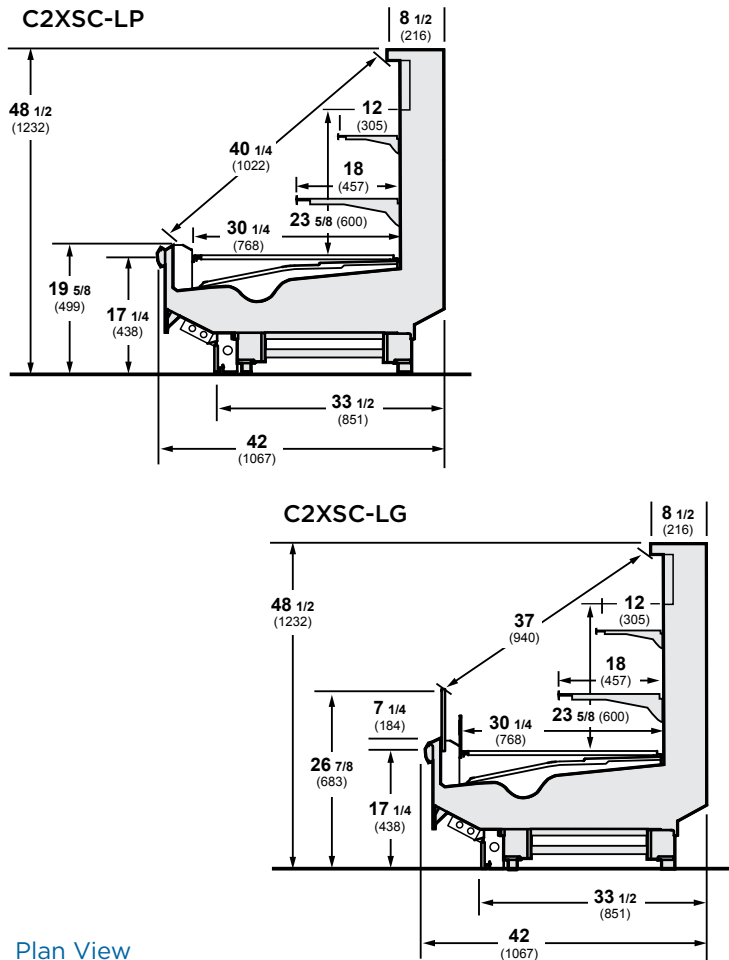

Dimensions	8 FT	12 FT
A	96 3/8 (2448)	144 1/2 (3670)

Note:
 Overall case length without ends or partitions. Contact your sales representative for information on possible availability of additional case lengths.

Superior Merchandising

The C2XSP has a short canopy for easier access and visibility to the top shelf. The LG model has glass front. The C2XSP provides quick, easy shopping access and merchandises a wide variety of refrigerated foods. Ideal for grab-n-go meals or other high margin prepared food selections such as sandwiches, prepared salads, pizza, etc.

Superior Shelf Life

Modular coils and off-time defrost work to reduce thermal shock and stabilize product temperatures, resulting in better freshness and longer shelf life. Modular defrost (optional) can further stabilize temperatures.

Lower Labor Costs

Labor-saving features include greater clearance under the case, easy-to-clean bathtub bottom with no coil in the bottom of the case, easier raceway access, 2-ft honeycomb sections and more.

Superior Reliability

Our 5 year modular coil warranty is the best available. Pre-set adjustable expansion valves are designed to hold optimal temperatures.

DOE 2012
 Energy Efficiency
 Compliant

Husmann refrigerated merchandisers configured for sale for use in the United States meet or surpass the requirements of the DOE 2012 energy efficiency standards.

NOTE: These merchandisers are designed for use in stores when temperature and humidity do not exceed 75°F and 55% R.H.

NOTE: We reserve the right to change or revise specifications and product design in connection with any feature of our products. Such changes do not entitle the buyer to corresponding changes, improvements, additions, or replacements for equipment previously sold or shipped.

For additional resources, contact your representative or visit www.husmann.com.

Note

Use Husmann's technical data sheets to get precise dimensions for all store layout purposes.

HUSMANN®

Husmann Corporation
 12999 St. Charles Rock Rd.
 Bridgeton, MO 63044-2483
 Ph: 314.291.2000

www.husmann.com