

HUSSMANN®



C3X-LGE, C3X-LGEP

Excel Multi-Deck Convertible Merchandisers
for All Medium Temperature Applications

www.hussmann.com

Husmann Excel Multi-Deck Convertible Merchandisers for Dairy, Deli, Pre-cut and Packaged Produce Applications

C3X-LGE - Multi-Deck Convertible, Low Front with Glass
C3X-LGEP - Multi-Deck Convertible, Low Front with Glass and E Plus Coils

Available in 8' and 12' lengths. Contact your sales rep for information on possible availability of additional case lengths.

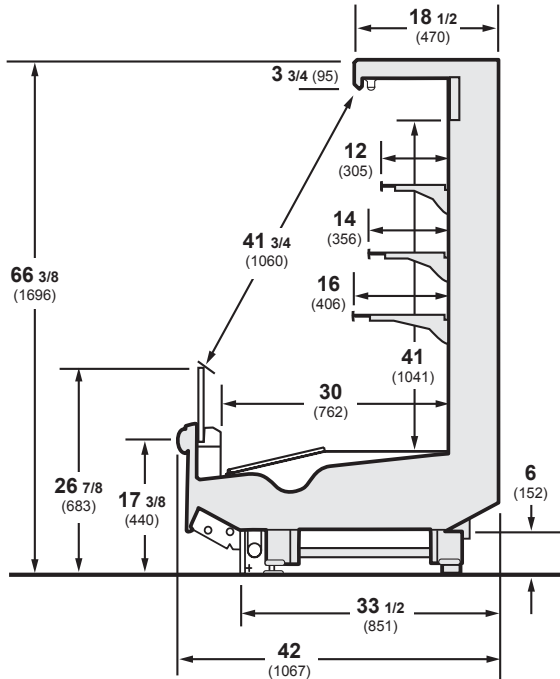

Plan View

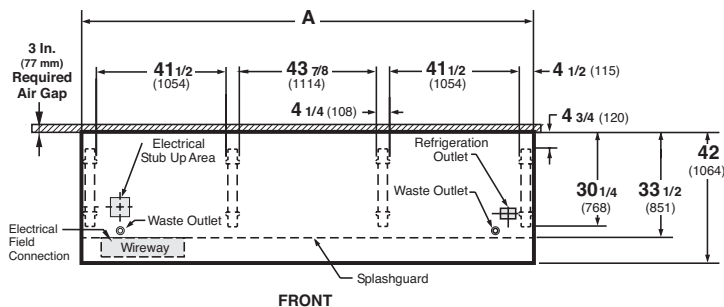

Dimensions	8 FT	12 FT
A	96 3/8 (2448)	144 1/2 (3670)

Notes:
 Case-to-case electrical connections are made in front of splashguard.
 Overall case length without ends or partitions.

Note

Use Husmann's technical data sheets to get precise dimensions for all store layout purposes.

Superior Merchandising.

The C3X is a medium capacity, high performance convertible merchandiser that will comfortably handle four merchandising levels. Shelves can be placed in any position due to the recessed shelf wiring harness channel in Excel. The C3X does an excellent job with any medium temperature product, including dairy, deli, pre-cut, and packaged produce. Its low front with glass provides merchandising flexibility and maximum product capacity.

Lower Energy Costs.

Standard high efficiency coils in the C3X keep energy costs down. Integrated night curtains and LED shelf and canopy lights are optionally available to further reduce energy costs.

Superior Shelf Life.

Modular coils and off-time defrost help reduce thermal shock and stabilize product temperatures.

Lower Labor Costs.

Labor saving features include easier access for cleaning under the case, easy-to-clean bathtub bottom (no coil in the bottom of the case) and simplified raceway access for quicker installation, and more.

Superior Reliability.

Our five-year modular coil warranty is the best available. Pre-set adjustable expansion valves are designed to hold optimal temperatures.

DOE 2017 Energy Efficiency Compliant Husmann refrigerated merchandisers configured for sale for use in the United States meet or surpass the requirements of the DOE 2017 energy efficiency standards.

NOTE: These merchandisers are designed for use in stores when temperature and humidity do not exceed 75°F and 55% R.H.

NOTE: We reserve the right to change or revise specifications and product design in connection with any feature of our products. Such changes do not entitle the buyer to corresponding changes, improvements, additions, or replacements for equipment previously sold or shipped.

For additional resources, contact your representative or visit www.husmann.com.

HUSMANN®

Husmann Corporation
 12999 St. Charles Rock Rd.
 Bridgeton, MO 63044-2483
 Ph: 314.291.2000

www.husmann.com