



C5X-GEP

5-Deck, Glass Front Convertible Merchandiser
for All Medium Temperature Applications

Hussmann 5-Deck, Glass Front Convertible Merchandiser for All Medium Temperature Applications

C5X-GEP - Convertible, 5-Deck, Glass Front, High Efficiency

Available in 8' and 12' lengths. Contact your sales rep for information on possible availability of additional case lengths.

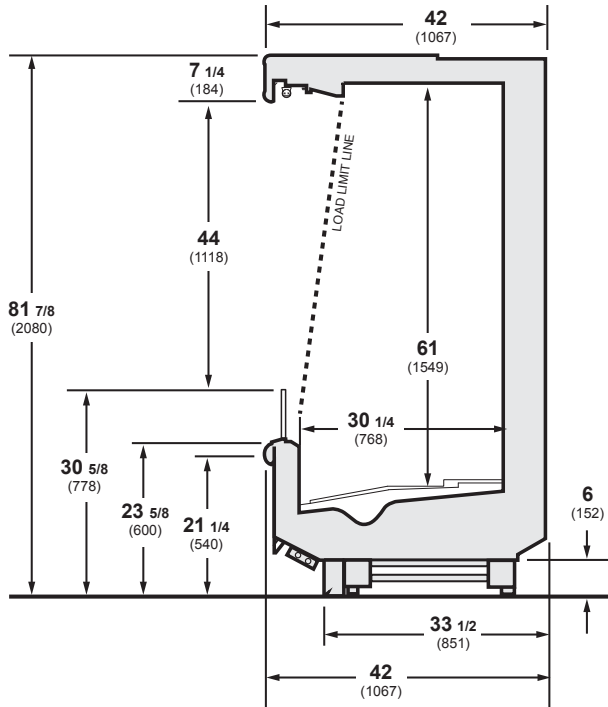

Plan View

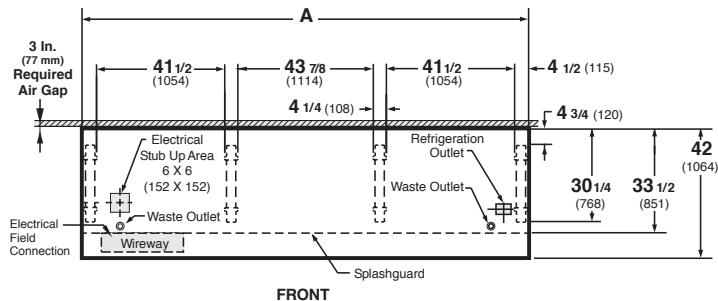

Dimensions	8 FT	12 FT
A	96 3/8 (2448)	144 1/2 (3670)

Notes:

Case-to-case electrical connections are made in front of splashguard.
Overall case length without ends or partitions.

Note

Use Hussmann's technical data sheets to get precise dimensions for all store layout purposes.

Large Capacity Display

The C5X-GEP provides large display capacity in a high performance convertible merchandiser. Ideal for any medium temperature product application. Glass front provides excellent product visibility while improving energy efficiency.

Lower Energy Costs

Glass front reduces energy use. High efficiency coils are standard, and integrated night curtains are optionally available to further reduce energy costs.

Lower Labor Costs

Labor-saving features include greater clearance under the case, easy-to-clean bathtub bottom with no coil in the bottom of the case, easier raceway access, 2-ft honeycomb sections and more.

Superior Shelf Life

Modular coils and off-time defrost work to reduce thermal shock and stabilize product temperatures.

Superior Reliability

Excellent five year modular coil warranty.



Hussmann refrigerated merchandisers configured for sale for use in the United States meet or surpass the requirements of the DOE 2017 energy efficiency standards.

NOTE: These merchandisers are designed for use in stores when temperature and humidity do not exceed 75°F and 55% R.H.

NOTE: We reserve the right to change or revise specifications and product design in connection with any feature of our products. Such changes do not entitle the buyer to corresponding changes, improvements, additions, or replacements for equipment previously sold or shipped.

For additional resources, contact your representative or visit www.hussmann.com.

HUSSMANN®

Hussmann Corporation
12999 St. Charles Rock Rd.
Bridgeton, MO 63044-2483
Ph: 314.291.2000

www.hussmann.com