



C6X-E

C6X-E, C6X-EP, C6X-LE, C6X-LEP

Excel High Capacity, Multi-Deck Convertible Merchandiser
for All Medium Temperature Applications

Husmann Excel High Capacity, Multi-Deck Convertible Merchandiser for All Medium Temperature Applications

C6X-E - High Capacity, Multi-Deck Convertible

C6X-EP - High Capacity, Multi-Deck Convertible, High Efficiency

C6X-LE - High Capacity, Multi-Deck Convertible with Low Front

C6X-LEP - High Capacity, Multi-Deck Convertible with Low Front, High Efficiency

Available in 8' and 12' lengths. Contact your sales rep for information on possible availability of additional case lengths.

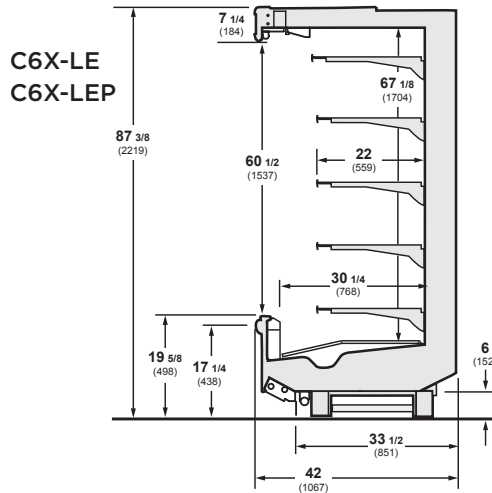
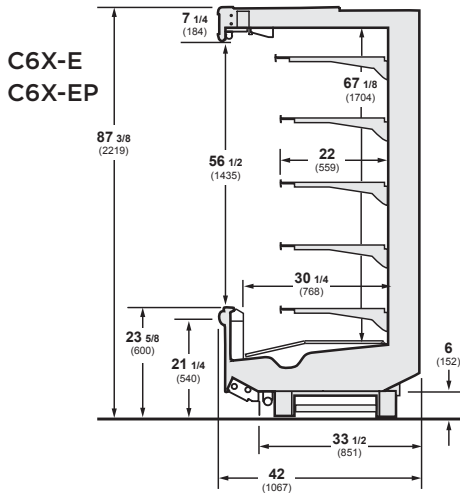

Plan View

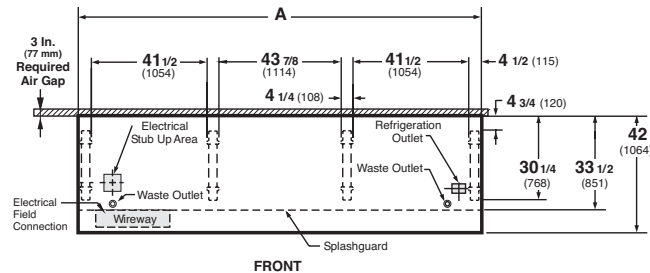

Dimensions	8 FT	12 FT
A	96 3/8 (2448)	144 1/2 (3670)

Notes:

Case-to-case electrical connections are made in front of splashguard. Overall case length without ends or partitions.

Note

Use Husmann's technical data sheets to get precise dimensions for all store layout purposes.

Superior Merchandising.

The C6X is designed to help you sell food. It is a high capacity convertible merchandiser that can hold any medium temp product, from fresh meat to dairy to cut produce. Full view glass ends and stainless steel reflective ends are two excellent display options that help you create an endless product view. Shelves can be positioned at any height for greater merchandising flexibility. Optional lighted canopy signs can be used to announce specials, advertise brands, promote store slogans and more.

Lower Energy Costs.

Standard high efficiency coils in the C6X help reduce your energy bills. The optional integrated night curtains will further reduce your energy costs.

Superior Shelf Life.

Modular coils with off-time defrost help keep refrigerated temperatures extremely stable, reducing thermal shock.

Lower Labor Costs.

Labor saving features include easier access for cleaning under the case, easy-to-clean bathtub bottom (no coil in the bottom of the case) and simplified raceway access for quicker installation, and more.

Superior Reliability.

Our five year modular coil warranty is the best available. Pre-set adjustable expansion valves are designed to hold optimal temperatures.

DOE 2017 Energy Efficiency Compliant Husmann refrigerated merchandisers configured for sale for use in the United States meet or surpass the requirements of the DOE 2017 energy efficiency standards.

NOTE: These merchandisers are designed for use in stores when temperature and humidity do not exceed 75°F and 55% R.H.

NOTE: We reserve the right to change or revise specifications and product design in connection with any feature of our products. Such changes do not entitle the buyer to corresponding changes, improvements, additions, or replacements for equipment previously sold or shipped.

For additional resources, contact your representative or visit www.husmann.com.

HUSSMANN®

Husmann Corporation
12999 St. Charles Rock Rd.
Bridgeton, MO 63044-2483
Ph: 314.291.2000

www.husmann.com