



CW2UGE

CW2UGE, CW2EGE, CW2GE

Excel Low Profile Multi-Deck
Unitized Convertible Island Merchandiser

Hussmann Excel Low Profile Multi-Deck Unitized Convertible Island Merchandiser

CW2U90GE - Unitized, 48" Height, 90" Length, Glass Front, High Efficiency
CW2U138GE - Unitized, 48" Height, 138" Length, Glass Front, High Efficiency

CW2GE - Center Case
CW2EGE - End Case

CW2UGE CW2GE

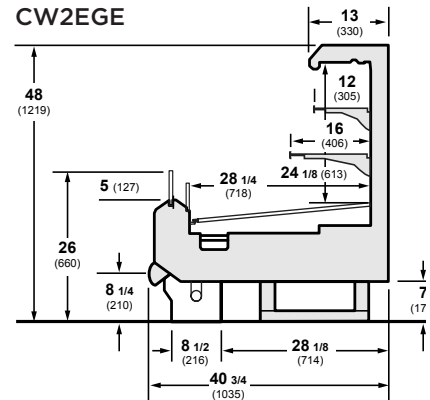
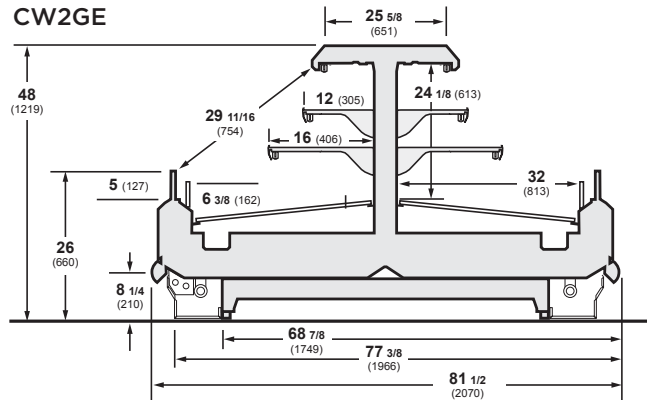

Plan View

CW2UGE

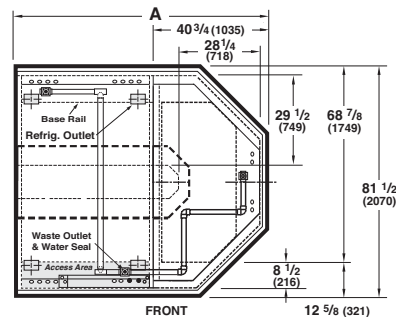

Dimensions	90 IN	138 IN
A	89 (2261)	137 (3480)

Notes: Electrical field wiring connection point.
 Overall case length without ends or partitions.

CW2GE

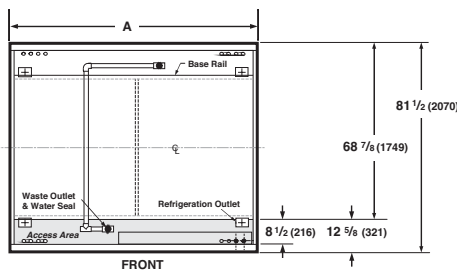

Dimensions	8 FT	12 FT
A	96 3/8 (2448)	144 1/2 (3670)

Notes: Electrical field wiring connection point.
 Overall case length without ends or partitions.

CW2EGE

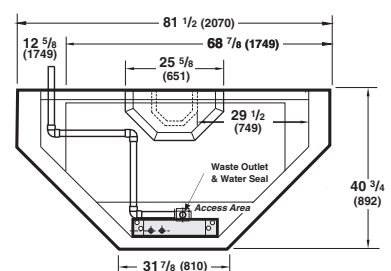

Notes: Maximum dimension of case (back to front) includes bumper. Overall case length without ends or partitions.

Note

Use Hussmann's technical data sheets to get precise dimensions for all store layout purposes.

Shop Around, Convertible Merchandising

Use with high margin items to help boost sales. This low height, convertible multi-deck island can be used for any medium temperature application. Great for prepared foods or other grab-n-go items. High visibility and easy access increase merchandising appeal.

Unitized Construction

The end and center portions of the "U" models are constructed as a single, unitized case. By connecting two unitized cases together at a single joint, adding an end case, or including additional center cases, you can have a complete shop around island of almost any length. The unitized design greatly simplifies installation.

Shelving Flexibility

Shelves are available in 12", 14", 16" and 18" depths. Shelves can be used for excellent display flexibility.



Hussmann refrigerated merchandisers configured for sale for use in the United States meet or surpass the requirements of the DOE 2017 energy efficiency standards.

NOTE: These merchandisers are designed for use in stores when temperature and humidity do not exceed 75°F and 55% R.H.

NOTE: We reserve the right to change or revise specifications and product design in connection with any feature of our products. Such changes do not entitle the buyer to corresponding changes, improvements, additions, or replacements for equipment previously sold or shipped.

For additional resources, contact your representative or visit www.hussmann.com.



Hussmann Corporation
 12999 St. Charles Rock Rd.
 Bridgeton, MO 63044-2483
 Ph: 314.291.2000

www.hussmann.com