



Model shown with options.

---

## D5X-LRE, D5X-RE

Excel Multi-Deck Dairy/Deli Displays  
with Rear Sliding Doors for Rear Loading

# Husmann Excel Multi-Deck Dairy/Deli Displays with Rear Sliding Doors for Rear Loading

**D5X-LRE** - Multi-Deck Dairy with Rear Sliding Doors, Low Front

**D5X-RE** - Multi-Deck Dairy with Rear Sliding Doors

Available in 8' and 12' lengths. Contact your sales rep for information on possible availability of additional case lengths.

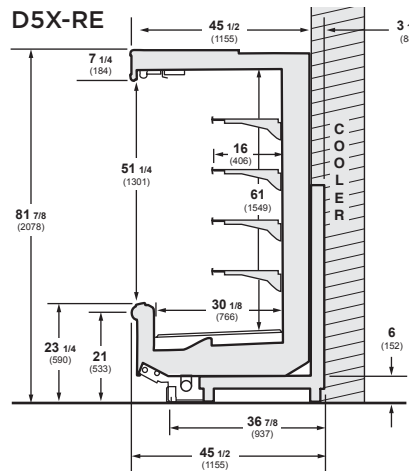
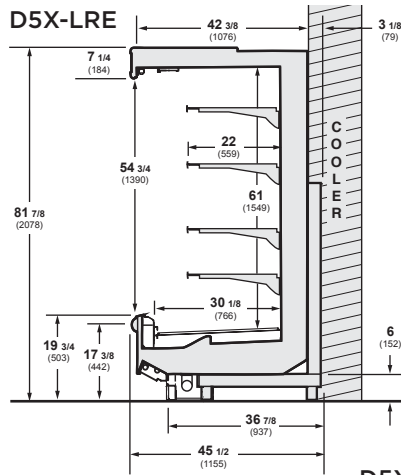

## Plan View

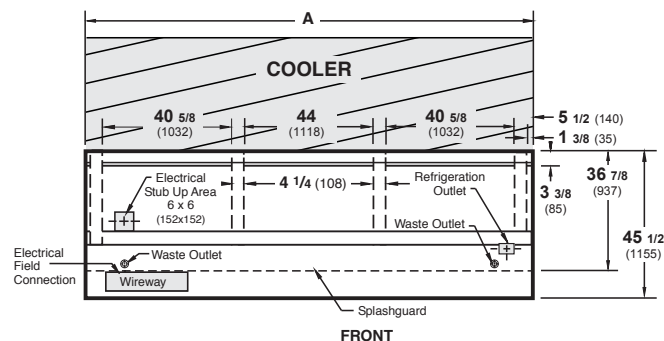

Dimensions	8 FT	12 FT
A	96 3/8 (2448)	144 1/2 (3670)

**Notes:**  
Case-to-case electrical connections are made in front of splashguard.  
Overall case length without ends or partitions.

## Rear Sliding Doors for Easy Stocking

The D5X-LRE and D5X-RE are designed for easy rear loading from a cooler adjacent to the back of the case. Product is stocked quickly and stays cold. This is a benefit in heavy traffic stores with rapid product turnover.

## Sliding Doors Provide Full Access

Doors are constructed in three panels, with one three panel door opening every four feet. The three panels can be slid together to the right or the left, so you have complete rear access to the full merchandising area in front of each door opening.

## Lower Labor Costs

The sliding doors decrease stocking time and free your labor for other tasks. Other labor saving features include greater clearance under the case, easier raceway access, 2-ft honeycomb sections and more.

## Superior Reliability

All Excel cases are built to last. Our 5 year coil warranty is the best available. Pre-set adjustable expansion valves are designed to hold optimal temperatures.

**DOE 2017 Energy Efficiency Compliant** Husmann refrigerated merchandisers configured for sale for use in the United States meet or surpass the requirements of the DOE 2017 energy efficiency standards.

NOTE: These merchandisers are designed for use in stores when temperature and humidity do not exceed 75°F and 55% R.H.

NOTE: We reserve the right to change or revise specifications and product design in connection with any feature of our products. Such changes do not entitle the buyer to corresponding changes, improvements, additions, or replacements for equipment previously sold or shipped.

For additional resources, contact your representative or visit [www.husmann.com](http://www.husmann.com).

## Note

Use Husmann's technical data sheets to get precise dimensions for all store layout purposes.

**HUSMANN®**

**Husmann Corporation**  
12999 St. Charles Rock Rd.  
Bridgeton, MO 63044-2483  
Ph: 314.291.2000

[www.husmann.com](http://www.husmann.com)