

HUSSMANN®

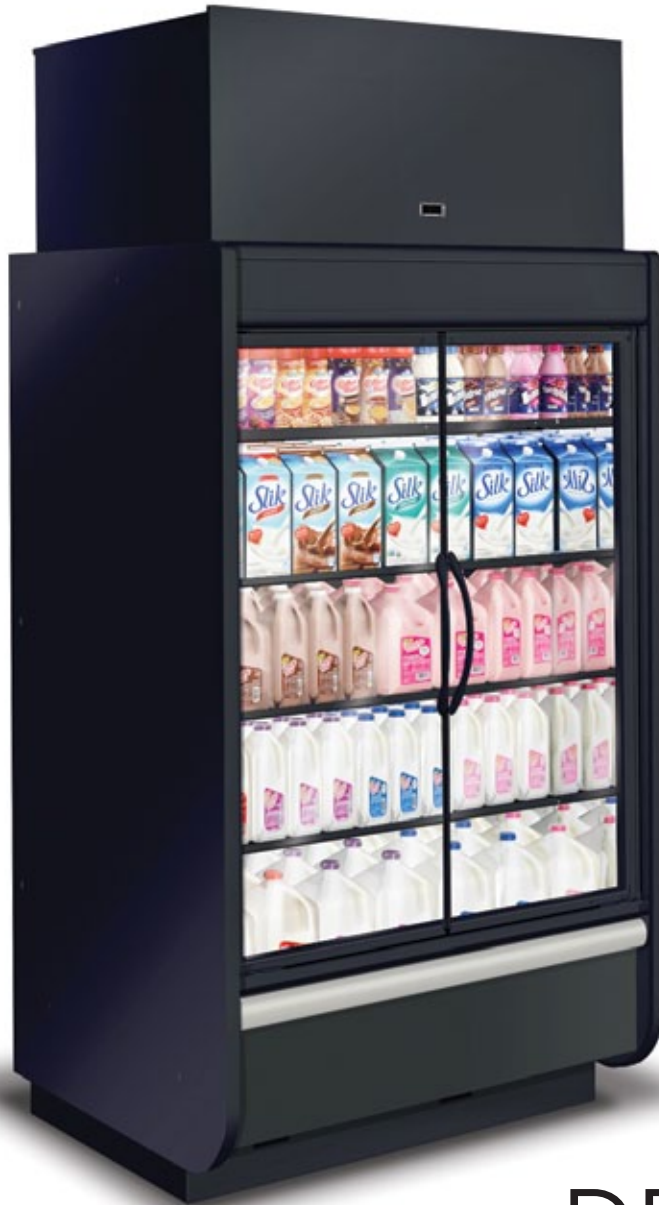

DDF5NX-L

Excel Freedom Line Multi-Deck Dairy/Deli Merchandiser
with Glass Doors, Narrow Footprint and Low Front

Husmann Excel Freedom Line Multi-Deck Dairy/Deli Merchandiser with Glass Doors, Narrow Footprint and Low Front

DDF5NX-L - Glass Doors, Freedom Line, 5-Deck, Narrow Footprint, Excel, Low Front

Available in 4' and 6' lengths. Contact your sales rep for information on possible availability of additional case lengths.

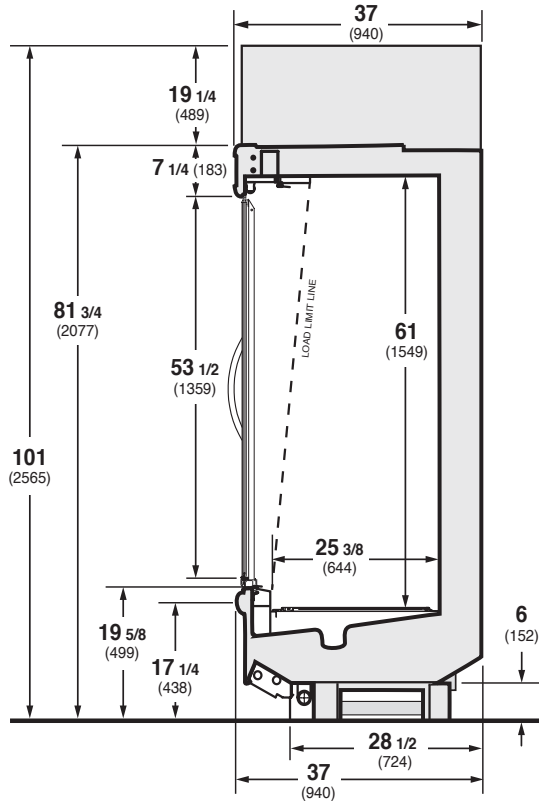

Plan View

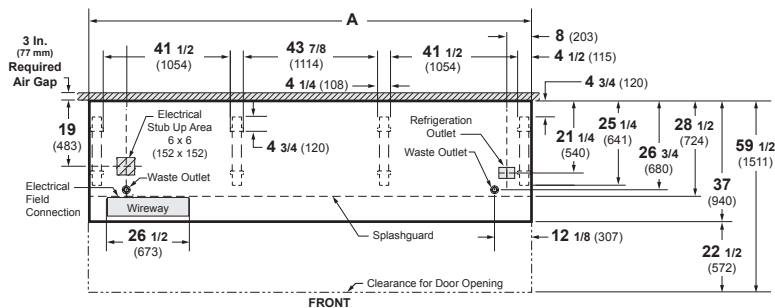

Dimensions	4 FT	6 FT
A	48 3/8 (1229)	72 3/8 (1838)

Note: Case-to-case electrical connections are made in front of splashguard. Overall case length without ends or partitions.

Note

Use Husmann's technical data sheets to get precise dimensions for all store layout purposes.

Features and Benefits

- Freedom Line cases offer choice of field installed refrigeration on top of case or remote refrigeration
- EcoVision glass doors provide excellent product visibility and reduce refrigeration energy up to 82%
- Low front for additional product facings
- Narrow footprint reduces floor space needed
- No heat required in doors or frames
- Energy efficient coils standard
- 5 year modular coil warranty

Options Include

- Various shelves, racks, lighting, paint and bumper colors
- Door frames, trim and handles available in gray and black
- Streamline or contour styling
- Illuminated canopy signs



Husmann refrigerated merchandisers configured for sale for use in the United States meet or surpass the requirements of the DOE 2017 energy efficiency standards.

NOTE: These merchandisers are designed for use in stores when temperature and humidity do not exceed 75°F and 55% R.H.

NOTE: We reserve the right to change or revise specifications and product design in connection with any feature of our products. Such changes do not entitle the buyer to corresponding changes, improvements, additions, or replacements for equipment previously sold or shipped.

For additional resources, contact your representative or visit www.husmann.com.



Husmann Corporation
12999 St. Charles Rock Rd.
Bridgeton, MO 63044-2483
Ph: 314.291.2000

www.husmann.com