

DDSS-4MC

Self-Contained, High Capacity Multi-Deck
Medium Temperature Merchandiser

- 29-Inch Deep Footprint

Advanced Design

- Maximum capacity in a 29-inch deep footprint
- Glass shelves - (3) 13-inch and (2) 9-3/4-inch, with silver PTM
- White interior and exterior
- Black front bumper
- Solid ends

Merchandising with Style

- Newly designed access panel
- Lighted sign

Smart Construction

- R-404A condensing unit (208/230V, 20A, cord connected)
- One row upper canopy light (T-8)
- Low profile casters
- CFC-free insulation

Innovative Refrigeration

- Type II (80°F and 55% R.H.) certified
- Electronic controls with digital display

Model shown with
optional view ends.



Self-Contained, High Capacity Multi-Deck Merchandiser for Beverage, Salad, and Sandwich Applications

DDSS-4MC - High Capacity Multi-Deck Merchandiser

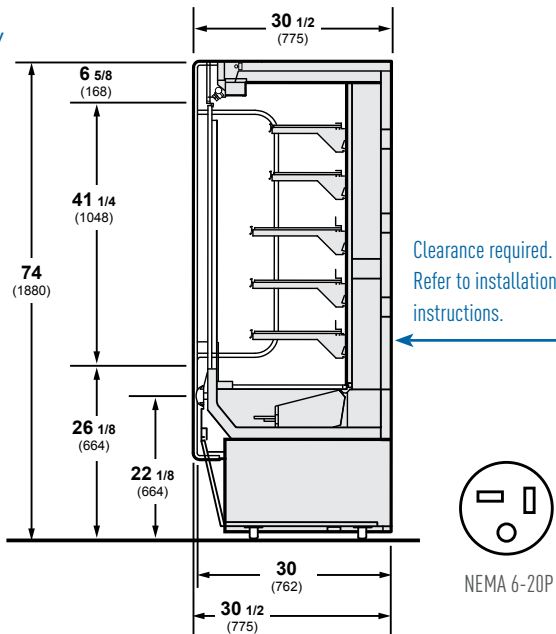

Plan View

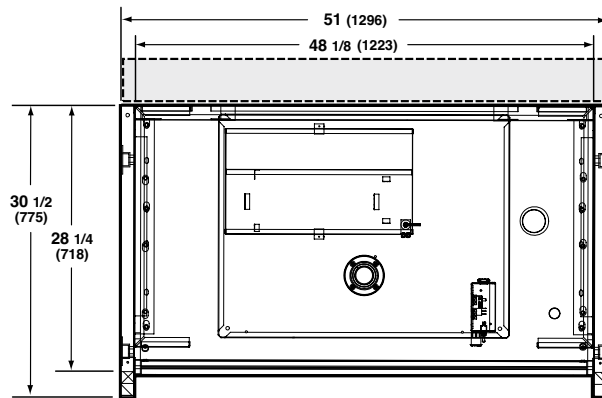

Specifications

Model	Exterior Dimensions			Nom. HP	Refrig.	Hz/Ph	Electrical			NEMA Plug	Approx. Ship Wt. (lbs)
	L	D	H				Run Amps	Fuse Amps	Volts		
DDSS-4MC	51"	30-1/2"	74"	3/4	R-404a	60/1	10.85	20	208-230	6-20P	900

Refrigeration load requirement: 6402 BTU/h @ 15°F evaporating, 110°F condensing temperature AC load requirement: 8623 BTU/h.

* Field hardwired.



Hussmann refrigerated merchandisers configured for sale for use in the United States meet or surpass the requirements of the DOE 2017 energy efficiency standards.



Type II

Standard Features.

- Color Exterior	White
- Color Interior	White
- Bumper	Black
- Glass Shelves	(3) 13" and (2) 9-3/4"
- Shelf Lighting	Yes
- Canopy Lighting	Yes
- End Panel	View
- Power Cord	Yes
- PTM	Silver
- NSF	Type II
- Air Discharge	Front
- Insulation	CFC-Free
- Casters	Yes
- Lighted Sign	Yes

Optional Accessories.

- Integrated night cover.
- Reversing condenser fan motor.
- Locking security cover.
- Leg kit.
- View ends.
- Mirror interior.
- Stainless steel exterior.
- 6-inch casters.
- Solid shelves (12-inch and 10-inch).
- Black or white PTM.
- Reversing product stop.

NOTE: These merchandisers are designed for use in stores when temperature and humidity do not exceed 80°F and 55% R.H. Case is designed for holding pre-frozen product only.

NOTE: We reserve the right to change or revise specifications and product design in connection with any feature of our products. Such changes do not entitle the buyer to corresponding changes, improvements, additions, or replacements for equipment previously sold or shipped.

For additional resources and warranties, contact your representative or visit www.hussmann.com.

HUSSMANN®

Hussmann Corporation
12999 St. Charles Rock Rd.
Bridgeton, MO 63044-2483
Ph: 314.291.2000

www.hussmann.com