

HUSSMANN®

Excel Merchandisers



DF5NX

Excel Freedom Line Narrow Multi-Deck Merchandiser
for Dairy and Deli Applications

www.husmann.com

Husmann Excel Freedom Line Narrow Multi-Deck Merchandiser for All Medium Temperature Applications

DF5NX - Dairy, Freedom Line, 5-Deck, Narrow Footprint, Excel
Available in 4', 6', 8', and 12' lengths.

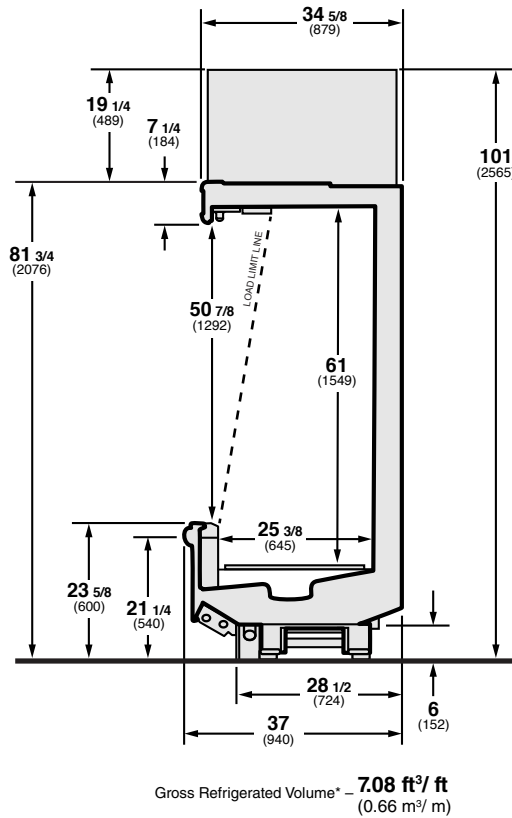

Plan View

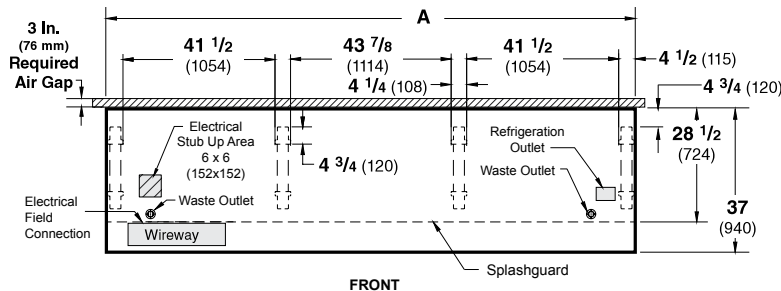

Dimensions	4 FT	6 FT	8 FT	12 FT
A	48 3/8 (1229)	72 3/8 (1838)	96 3/8 (2448)	144 1/2 (3670)

Notes:
Case-to-case electrical connections are made in front of splashguard. Overall case length without ends or partitions.

Note

Use Husmann's technical data sheets to get precise dimensions for all store layout purposes.

Features and Benefits

- Freedom Line cases offer choice of field installed refrigeration on top of case or remote refrigeration
- Narrow depth conserves floor space
- Energy efficient coils standard
- 5 year modular coil warranty

Easy Installation

- No drains required: condensate removal system with field installed pump and condensate pan
- Refrigeration lines are pre-charged and pre-piped to top of case with quick-connect, threaded couplings for easy condensing unit installation
- Pre-wired and labeled to simplify electrical connections
- Matching facade conceals top-mounted refrigeration electrical components

Options Include

- Various shelves, racks, lighting, paint and bumper colors
- Door frames, trim and handles available in gray and black
- Streamline or contour styling
- Illuminated canopy signs

DOE 2017 Energy Efficiency Compliant Husmann refrigerated merchandisers configured for sale for use in the United States meet or surpass the requirements of the DOE 2017 energy efficiency standards.

NOTE: These merchandisers are designed for use in stores when temperature and humidity do not exceed 75°F and 55% R.H.

NOTE: We reserve the right to change or revise specifications and product design in connection with any feature of our products. Such changes do not entitle the buyer to corresponding changes, improvements, additions, or replacements for equipment previously sold or shipped.

For additional resources, contact your representative or visit www.husmann.com.

HUSSMANN®

Husmann Corporation
12999 St. Charles Rock Rd.
Bridgeton, MO 63044-2483
Ph: 314.291.2000

www.husmann.com