

**HUSSMANN®**

---

Specialty



---

# DSI-03, DSRPI-03

Island Produce Display  
- Dry or Refrigerated

# Hussmann Island Produce Display - Dry or Refrigerated

## DSI-03, DSRPI-03

### Exterior Styling

Custom panels can be added to match your store's produce department design.



### Flexible Merchandising

Built to your produce department's requirements for center divider and product height. In addition, we can supply flat racks or multi-level steps.

### DSRPI Remote - 6' Wide:

Lengths: 8', 10', 12', 14', 16', 18', 20', 22', and 24'

### DSI Dry - 6' Wide:

Lengths: 8', 10', 12', 14', 16', 18', 20', 22', and 24'

#### DSI-03

Standard Section shown with Optional Ledge Lights

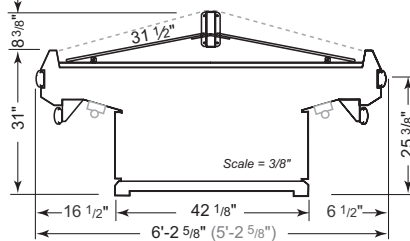

#### DSRPI-03

Shelf and Rack Option

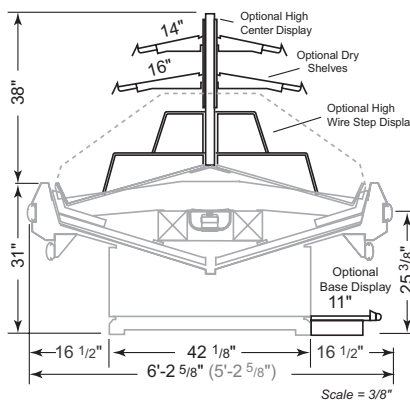

#### DSRPI-03 Plan View

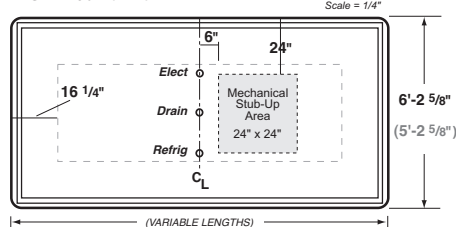

NOTE: Mechanical Stub-Up areas will vary with size of case. Consult factory for location(s)

### Features.

- Low center divider - 8" aluminum
- Impact body styles
- Green epoxy flat wire racks
- Energy efficient fans
- Painted exterior
- Urethane deck non-insulated (dry)
- Plastic product dividers every 24"
- Price tag wire with chrome posts
- 3" Black vinyl cart bumpers (Impact style)
- Insulated urethane interior (refrigerated)
- Package-type forced air coil (refrigerated)
- Solar digital thermometer (refrigerated)
- Please reference color chart for choice of standard Hussmann paint and finish options ([www.hussmann.com](http://www.hussmann.com))

### Options.

- Green epoxy step wire racks with plastic product dividers every 24"
- Scale hangers (single/double)
- Adjustable stainless steel shelves (14", 16" non-refrigerated)
- Bag dispensers
- Price tag molding
- Perimeter ledge LED
- Solid urethane-coated fixed steps (dry)
- Additional product dividers
- Water outlets with quick disconnect (refrigerated)
- Water spray hose (refrigerated)
- Custom decor
- High center divider (24", 30", 38")
- 5' wide case
- Custom exterior body panels, lengths and options\* (consult your Hussmann sales representative)

**Note: Does not hold processed produce or juice temperatures.**

**DOE 2017 Energy Efficiency Compliant**

Hussmann refrigerated merchandisers configured for sale for use in the United States meet or surpass the requirements of the DOE 2017 energy efficiency standards.

\* Some optional features may need to be certified by UL, NSF, and/or other 3rd party certification agencies. Contact Hussmann for verification or questions for availability.

† Only lighting configurations that are compliant with the U.S. Dept. of Energy (DOE) 2017 regulation are available for sale for use in the U.S.A.

NOTE: These merchandisers are designed for use in stores when temperature and humidity do not exceed 75°F and 55% R.H. We reserve the right to change or revise specifications and product design in connection with any feature of our products. Such changes do not entitle the buyer to corresponding changes, improvements, additions, or replacements for equipment previously sold or shipped.

For additional resources, contact your representative or visit [www.hussmann.com](http://www.hussmann.com).



### Note.

Use Hussmann's technical data sheets to get precise dimensions for all store layout purposes.

**Intertek Intertek**

### Hussmann Specialty

13770 Ramona Avenue  
Chino, California 91710-5423  
Ph: 800.395.9229

[www.hussmann.com](http://www.hussmann.com)

**HUSSMANN®**