



ESGMVS

Elite Vertical Glass Service Case with Gravity
and Serpentine Coils for Deli and Meat Applications

Husmann Elite Vertical Glass Service Case with Gravity and Serpentine Coils for Deli and Meat Applications

ESGMVS - Straight Glass Service Case with Gravity Coil

Available in 8' and 12' lengths. Contact your sales rep for information on possible availability of additional case lengths.

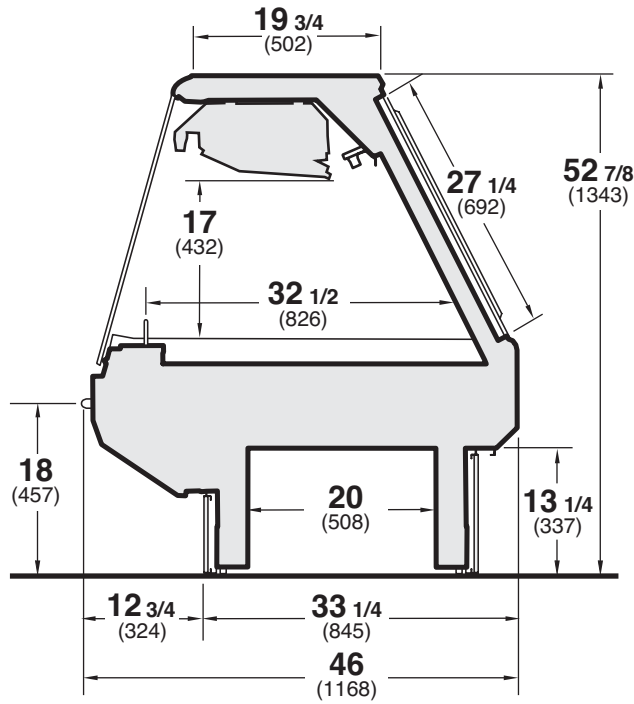

Plan View

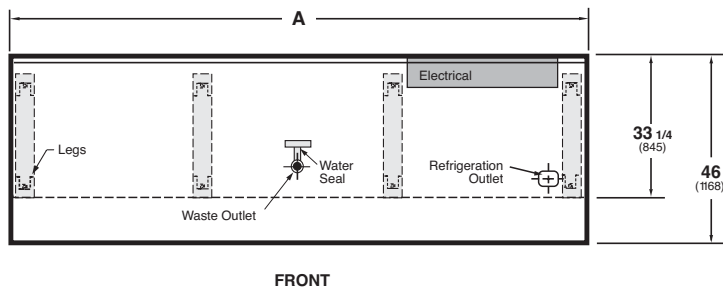

Dimensions	8 FT	12 FT
A	96 3/8 (2448)	144 1/2 (3670)

Notes:

Overall case length without ends or partitions. Contact your sales representative for information on possible availability of additional case lengths.

Note

Use Husmann's technical data sheets to get precise dimensions for all store layout purposes.

Traditional Vertical Glass Deli Merchandising with Elite Styling.

The ESGMVS is a gravity coil merchandiser providing the benefits of more traditional, nearly vertical straight glass deli service displays in dramatic Elite styling. This can be great in deli departments designed with a more traditional yet clearly high quality style in mind. The signature straight front glass, which is nearly but not quite vertical, lifts up for easy stocking and cleaning.

Large Top Display for Convenience and Cross-Merchandising.

The vertical glass provides room for a large, 19 3/4-inch top display area. This can be used for cross-merchandising non-refrigerated items, for scale stands, and for extra space when serving customers.

Proven Performance.

Husmann's advanced refrigerated technology is available in all Elite merchandisers, giving you better product temperatures, lower energy costs, fewer refrigerant leaks, and easier cleaning and maintenance. Get ultimate styling and ultimate performance with Elite.

Available Accessories.

ESGMVS accessories include scale stands, wrapping boards, step displays, paper cutters and a 2-inch base elevation kit.

At last, advanced styling plus world-class performance and energy efficiency... that's Elite.



Husmann refrigerated merchandisers configured for sale for use in the United States meet or surpass the requirements of the DOE 2017 energy efficiency standards.

NOTE: These merchandisers are designed for use in stores when temperature and humidity do not exceed 75°F and 55% R.H.

NOTE: We reserve the right to change or revise specifications and product design in connection with any feature of our products. Such changes do not entitle the buyer to corresponding changes, improvements, additions, or replacements for equipment previously sold or shipped.

For additional resources, contact your representative or visit www.husmann.com.

HUSMANN®

Husmann Corporation
12999 St. Charles Rock Rd.
Bridgeton, MO 63044-2483
Ph: 314.291.2000

www.husmann.com