



FN

Excel Narrow Island
Frozen Foods/Ice Cream Merchandiser

Husmann Excel Narrow Island Merchandiser for Frozen Food/Ice Cream Applications

FN - Narrow Island Merchandiser

Available in 8' and 12' lengths. Contact your sales rep for information on possible availability of additional case lengths.

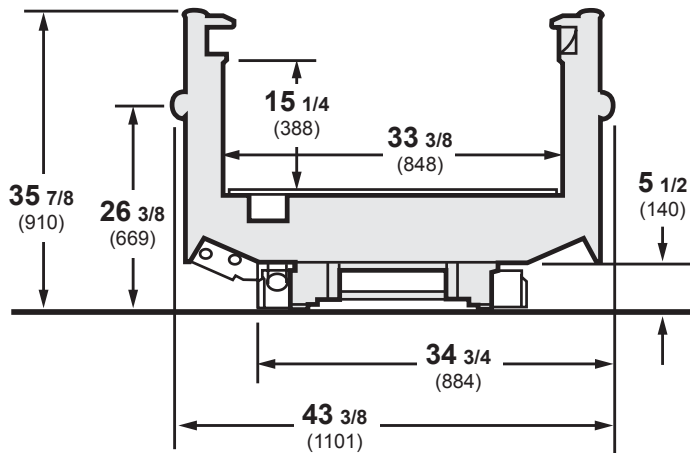

Plan View

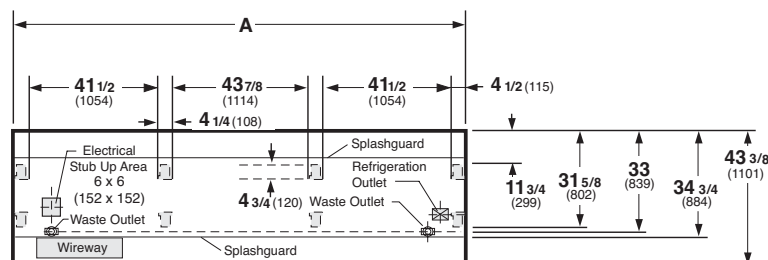

FRONT

Dimensions	8 FT	12 FT
A	96 3/8 (2448)	144 1/2 (3670)

Notes:

Case-to-case electrical connections are made in front of splashguard.

Overall case length without ends or partitions. Contact your sales representative for information on possible availability of additional case lengths.

Note

Use Husmann's technical data sheets to get precise dimensions for all store layout purposes.

More Energy Efficient

The Excel FN has improved energy efficiency compared to Impact and all competitive models.

More Merchandising Capacity

Compared with the standard Impact model, the Excel FN narrow island provides 5% more merchandising space.

Superior Shelf Life

Excellent temperature consistency and stability throughout the display zone due to Husmann's proprietary discharge air louvers and continuous tube serpentine coils.

Lower Labor Costs

Labor saving features include greater clearance under the case, easier raceway access and simplified wiring.

Superior Reliability

Our five year coil warranty is the best available. Pre-set adjustable expansion valves are designed to hold optimal temperatures.

Sliding Glass Lids Available

Sliding glass lids are available as a field installed upgrade or as original equipment for all single deck, open island display cases. Lids will reduce overall case energy from 40% to 60%, depending on case model.

DOE 2017 Energy Efficiency Compliant Husmann refrigerated merchandisers configured for sale for use in the United States meet or surpass the requirements of the DOE 2017 energy efficiency standards.

NOTE: These merchandisers are designed for use in stores when temperature and humidity do not exceed 75°F and 55% R.H.

NOTE: We reserve the right to change or revise specifications and product design in connection with any feature of our products. Such changes do not entitle the buyer to corresponding changes, improvements, additions, or replacements for equipment previously sold or shipped.

For additional resources, contact your representative or visit www.husmann.com.

HUSSMANN®

Husmann Corporation
12999 St. Charles Rock Rd.
Bridgeton, MO 63044-2483
Ph: 314.291.2000

www.husmann.com