

FWGH

FWGH, FWEGH

Excel Wide Island Frozen Food Merchandiser
with Extra Tall Glass Sides

Hussmann Excel Wide Island Display with Extra Tall Glass Sides for Frozen Food Applications

FWGH - Wide Island with Extra Tall Glass Sides
Available in 8' and 12' lengths.

FWEGH - Wide Island End Case with Extra Tall Glass Sides

Contact your sales rep for information on possible availability of additional case lengths.

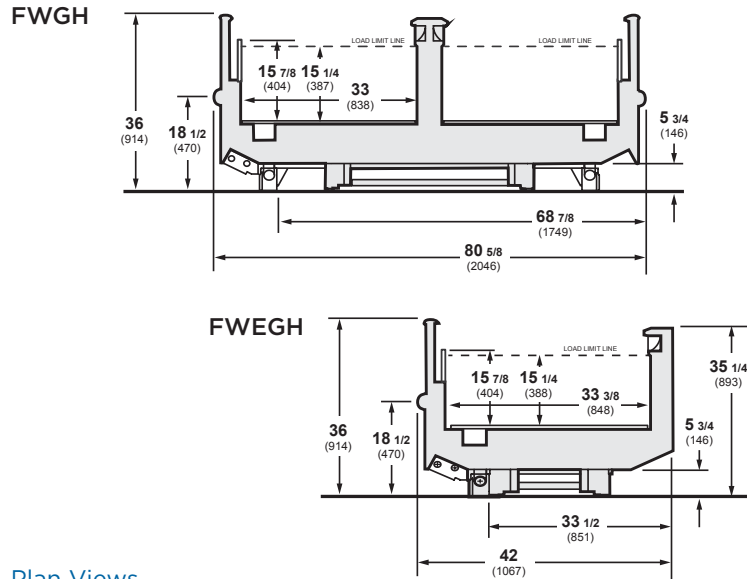

Plan Views

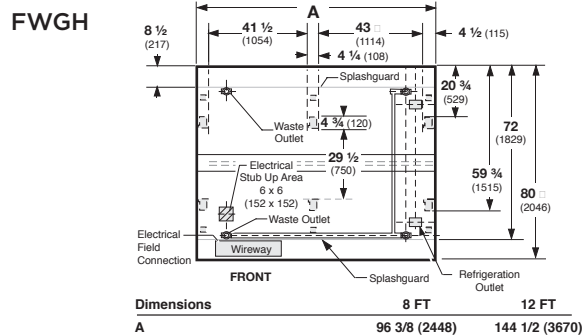

Notes: Overall case length without ends or partitions.

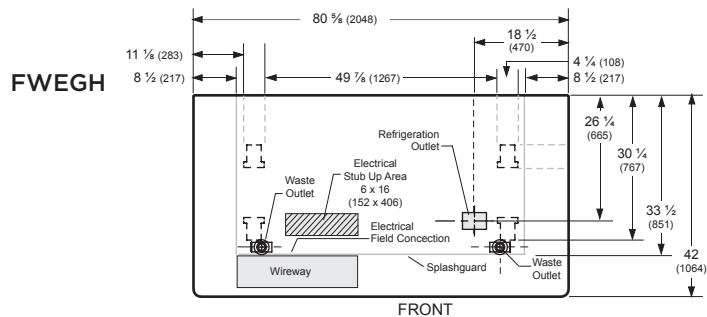

Notes: Overall case length without ends or partitions.

Note Use Hussmann's technical data sheets to get precise dimensions for all store layout purposes.

Features / Benefits

- The FWGH is a wide island display with extra tall glass for superior product visibility and merchandising
- Often used as a central line-up in a frozen food department
- Excellent for a wide range of frozen entrees, side dishes, and desserts
- Superior merchandising capacity
- Excellent temperature consistency and stability throughout the display zone due to Hussmann's proprietary discharge air louvers and continuous tube serpentine coils
- Solid reliability with a 5-year coil warranty and pre-set, adjustable expansion valves that are designed to hold optimal temperatures
- The wide open, parallel wells are easy to stock and shop
- The FWEGH, also with extra tall glass, can be used to create an adjoining end cap well

Options Include

- Various paint and bumper color options
- Sliding glass lids for Island Merchandisers
 - Sliding lids provide full access to all products
 - Glass lids provide substantial reduction in energy costs
 - Excellent product visibility through glass lids
 - Can be ordered with original equipment or as a field installed upgrade

DOE 2017 Energy Efficiency Compliant Hussmann refrigerated merchandisers configured for sale for use in the United States meet or surpass the requirements of the DOE 2017 energy efficiency standards.

NOTE: These merchandisers are designed for use in stores when temperature and humidity do not exceed 75°F and 55% R.H.

NOTE: We reserve the right to change or revise specifications and product design in connection with any feature of our products. Such changes do not entitle the buyer to corresponding changes, improvements, additions, or replacements for equipment previously sold or shipped.

For additional resources, contact your representative or visit www.hussmann.com.

HUSSMANN®

Hussmann Corporation
12999 St. Charles Rock Rd.
Bridgeton, MO 63044-2483
Ph: 314.291.2000

www.hussmann.com