



FWG

FW, FWG, FWE, FWEG

Excel Wide Island Frozen Foods/Ice Cream Merchandiser
with Glass Sides

Husmann Excel Wide Island Merchandiser with Glass Sides for Frozen Food/Ice Cream Applications

FW - Wide Island

FWG - Wide Island with Glass Sides

FWE - Wide Island End Case

FWEG - Wide Island End Case with Glass Sides

Available in 8' and 12' lengths. Contact your sales rep for information on possible availability of additional case lengths.

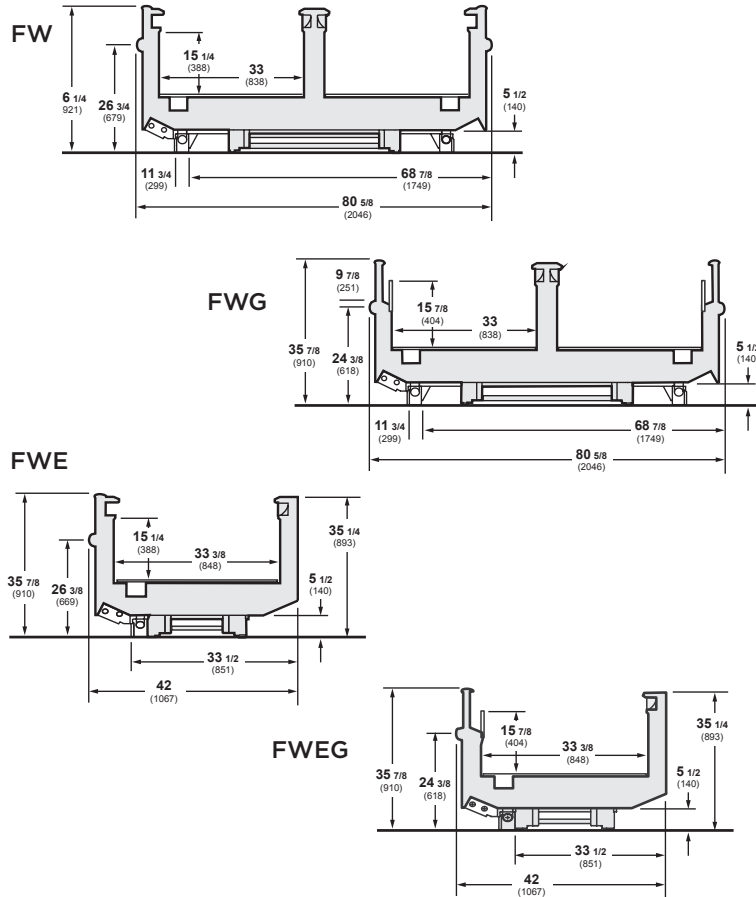

Plan Views

FW, FWG

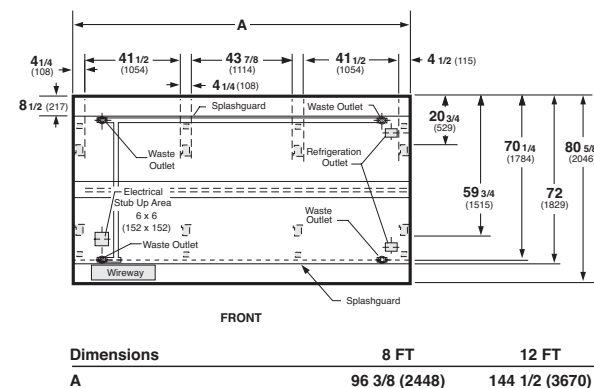

FWE, FWEG

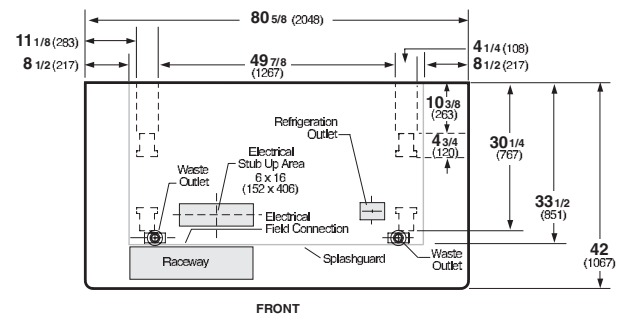

More Energy Efficient

Excel Energy Efficiency Advantage*

Excel	vs. Impact	Competitor 1	Competitor 2	Competitor 3
FW	vs. 19%	22%	38%	29%
FWG	vs. 28%	38%	31%	29%
FWE	vs. 3%	39%	33%	34%
FWEG	vs. 30%	46%	30%	34%

*Based on April, 2005 published data.

More Merchandising Capacity

Excel Capacity Advantage vs. Impact:

- FW	- 6%	- FWE	- 5%
- FWG	- 11%	- FWEG	- 10%

Superior Shelf Life

Excellent temperature consistency and stability throughout the display zone due to Husmann's proprietary discharge air louvers and continuous tube serpentine coils.

Lower Labor Costs

Labor saving features include greater clearance under the case, easier raceway access, and simplified wiring.

Superior Reliability

Our 5 year coil warranty is the best available. Pre-set adjustable expansion valves are designed to hold optimal temperatures.

Sliding Glass Lids Available

Sliding glass lids are available as a field installed upgrade or as original equipment for all single deck, open island display cases. Lids will reduce overall case energy from 40% to 60%, depending on case model.



Husmann refrigerated merchandisers configured for sale for use in the United States meet or surpass the requirements of the DOE 2017 energy efficiency standards.

NOTE: These merchandisers are designed for use in stores when temperature and humidity do not exceed 75°F and 55% R.H.

NOTE: We reserve the right to change or revise specifications and product design in connection with any feature of our products. Such changes do not entitle the buyer to corresponding changes, improvements, additions, or replacements for equipment previously sold or shipped.

For additional resources, contact your representative or visit www.husmann.com.

Note Use Husmann's technical data sheets to get precise dimensions for all store layout purposes.

HUSMANN®

Husmann Corporation
12999 St. Charles Rock Rd.
Bridgeton, MO 63044-2483
Ph: 314.291.2000

www.husmann.com