

HUSSMANN®

Insight® Merchandisers



IC2XSL

IC2XSL, IC2XSM

Hussmann Insight 2-Deck Convertible Merchandisers,
Extra Tall for Multiple Applications

Two versatile styling options



CANOPY



BUMPER

Ellipse



CANOPY



BUMPER

Faceted

Enabling Excellence in Food Retailing.

Hussmann Insight® 2-Deck Convertible Merchandisers, Extra Tall for Multiple Applications

IC2XSL - Insight, Convertible, 2-Deck, Extra Tall
Standard Front-to-Back Depth, Low Front

IC2XSM - Insight, Convertible, 2-Deck, Extra Tall
Standard Front-to-Back Depth, Medium Front

Available in 4', 6', 8' and 12' lengths.

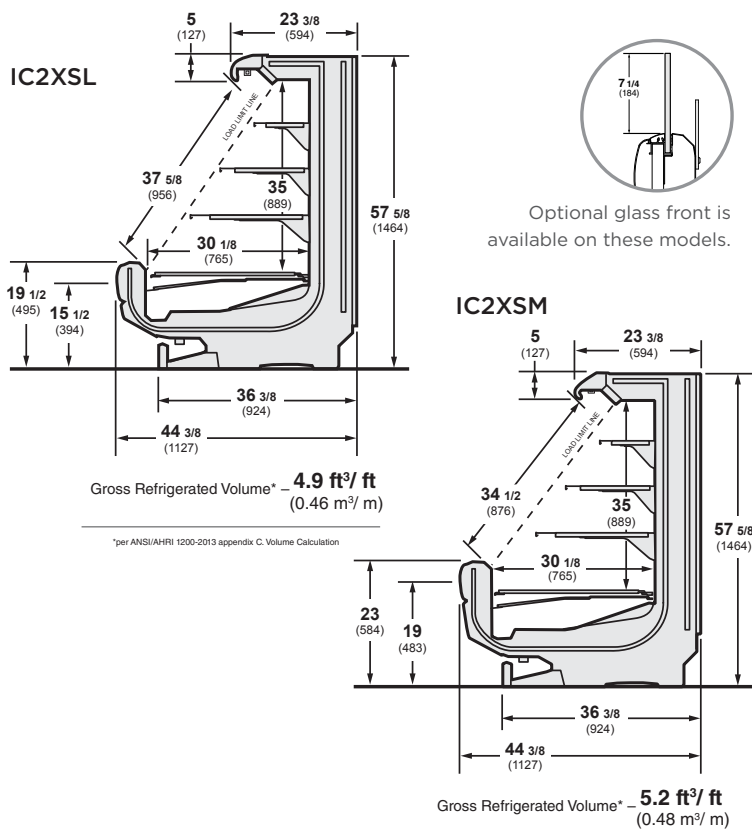

Plan View

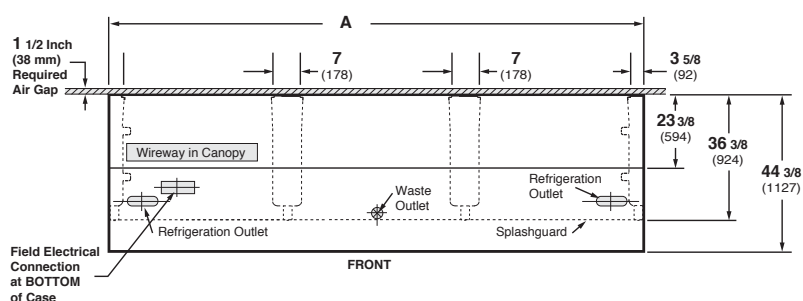

Dimensions	4 FT	6 FT	8 FT	12 FT
A	48 1/8 (1222)	72 1/4 (1835)	96 1/4 (2445)	144 3/8 (3668)

Note: Overall case length without ends or partitions. Contact your sales representative for information on possible availability of additional case lengths.

Note

Use Hussmann's technical data sheets to get precise dimensions for all store layout purposes.

Features / Benefits

- The IC2XS family is about 8 inches taller than the similar IC2S cases
- Ideal for sandwiches, packaged meal solutions, prepared salads, pizza, and more
- Excellent self-service addition to a deli department
- **Superior Food Quality**
 - More stable and uniform product temperatures to maintain freshness
 - Shorter defrost cycles protect food integrity
- **Energy and Sustainability Benefits**
 - 17% case energy savings on average vs. other currently available Hussmann products
 - EcoShine II LED lights standard, up to 71% more efficient than fluorescents
 - Over 30% less refrigerant in coils vs. previous coil designs
- **Better Structural Integrity**
 - Unibody construction improves integrity, facilitates moving, joining, and setting cases
 - New joining system, gasket channel and other new features simplify installation
- **Easier to Clean, Better Sanitation**
 - Electrical parts/connections in splash zone can be sprayed with water, rated IP 67
 - New anti-clog drain strainer
 - Coil in back wall and flip-up fan plenums for easy-to-clean case bottom
 - Seamless plastic "bathtub" bottom helps prevent leaks
- **Easier Service**
 - Flip-up access door on optional bottom rack for easy access to drain, fans, and valves
 - Standard LED lights reduce relamping and other maintenance costs
- **Superior Merchandising**
 - Ellipse and faceted design options to align with store image
 - Convertible merchandising for multiple applications
 - EcoShine II LED lighting standard, customized for optimal product lighting
 - Improved air curtain reduces "cold aisle" effect by 2-3° F

Options

- Various ends, lighting, shelves, racks, paint and bumper colors
- Two basic styling options, ellipse and faceted, with mix and match alternatives
- Flip-up bottom rack for easier cleaning/service
- Options available on most models to adjust performance to Type II climatic conditions



Hussmann refrigerated merchandisers configured for sale for use in the United States meet or surpass the requirements of the DOE 2017 energy efficiency standards.

NOTE: These merchandisers are designed for use in stores when temperature and humidity do not exceed 75°F (23.9°C) and 55% R.H.

NOTE: We reserve the right to change or revise specifications and product design in connection with any feature of our products. Such changes do not entitle the buyer to corresponding changes, improvements, additions, or replacements for equipment previously sold or shipped.

HUSSMANN®

Hussmann Corporation
12999 St. Charles Rock Rd.
Bridgeton, MO 63044-2483
Ph: 314.291.2000

www.hussmann.com