

**HUSSMANN®**

Insight® Merchandisers



# IC4SL

Insight 4-Deck Convertible Merchandiser  
with Low Front for Medium Temperature Applications

Two versatile styling options



CANOPY



BUMPER

**Ellipse**



CANOPY



BUMPER

**Faceted**

Enabling Excellence in Food Retailing.

# Hussmann Insight® 4-Deck Convertible Merchandiser with Low Front for Medium Temperature Applications

## IC4SL - Insight Convertible, 4-Deck, Standard Front-to-Back Depth, Low Front

Available in 4', 6', 8' and 12' lengths.

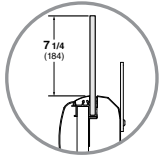

Optional glass front is available on this model.

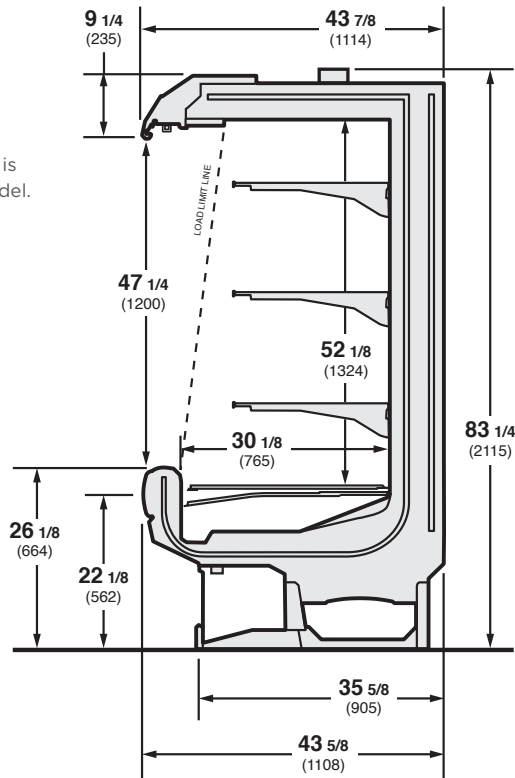

Gross Refrigerated Volume\* – **10.15 ft<sup>3</sup>/ft**  
(0.94 m<sup>3</sup>/m)

\*per ANSI/AHRI 1200-2013 appendix C, Volume Calculation

### Plan View

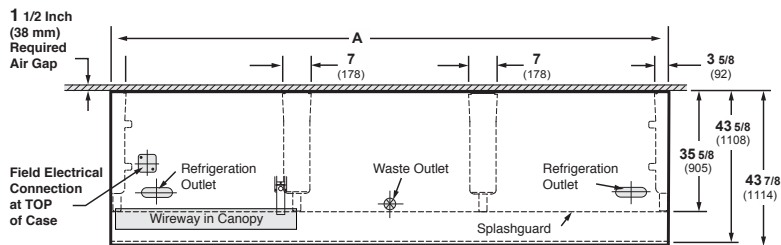

Dimensions	4 FT	6 FT	8 FT	12 FT
A	48 1/8 (1222)	72 1/4 (1835)	96 1/4 (2445)	144 3/8 (3668)

**Note: Overall case length without ends or partitions. Contact your sales representative for information on possible availability of additional case lengths.**

### Note

Use Hussmann's technical data sheets to get precise dimensions for all store layout purposes.

### Features / Benefits

- Convertible multi-deck merchandising
- Can be used for many medium temperature applications, including meat, cheese, produce, deli items, grab and go foods and more
- Superior Food Quality
  - More stable and uniform product temperatures to maintain freshness
  - Shorter defrost cycles protect food integrity
- Energy and Sustainability Benefits
  - 17% case energy savings on average vs. other currently available Hussmann products
  - EcoShine II LED lights standard, up to 71% more efficient than fluorescents
  - Over 30% less refrigerant in coils vs. previous coil designs
- Better Structural Integrity
  - Unibody construction improves integrity, facilitates moving, joining, and setting cases
  - New joining system, gasket channel, and other new features simplify installation
- Easier to Clean, Better Sanitation
  - Electrical parts/connections in splash zone can be sprayed with water, rated IP 67
  - New anti-clog drain strainer
  - Coil in back wall and flip-up fan plenums for easy-to-clean case bottom
  - Seamless plastic "bathtub" bottom helps prevent leaks
- Easier Service
  - Flip-up access door on optional bottom rack for easy access to drain, fans, and valves
  - Standard LED lights reduce relamping and other maintenance costs
- Superior Merchandising
  - Ellipse and faceted design options to align with store image
  - Convertible merchandising for multiple applications
  - EcoShine II LED lighting standard, customized for optimal product lighting
  - Improved air curtain reduces "cold aisle" effect by 2-3° F

### Options

- Various ends, lighting, shelves, racks, paint, and bumper colors
- Two basic styling options, ellipse and faceted, with mix and match alternatives
- Flip-up bottom rack for easier cleaning/service
- Options available on most models to adjust performance to Type II climatic conditions



Hussmann refrigerated merchandisers configured for sale for use in the United States meet or surpass the requirements of the DOE 2017 energy efficiency standards.

**NOTE:** These merchandisers are designed for use in stores when temperature and humidity do not exceed 75°F (23.9°C) and 55% R.H.

**NOTE:** We reserve the right to change or revise specifications and product design in connection with any feature of our products. Such changes do not entitle the buyer to corresponding changes, improvements, additions, or replacements for equipment previously sold or shipped.

**HUSSMANN®**

### Hussmann Corporation

12999 St. Charles Rock Rd.  
Bridgeton, MO 63044-2483  
Ph: 314.291.2000

[www.hussmann.com](http://www.hussmann.com)