

**HUSSMANN®**

Insight® Merchandisers



**microDS™**

**ID5SM-W**

Self-Contained Propane R290  
Natural Refrigerant Merchandiser

5-Level Multi-Deck with Medium Front  
for Deli, Dairy and Beverage Applications

Two versatile styling options

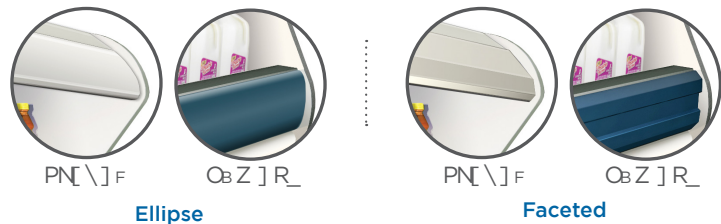

**Ellipse**

**Faceted**

Enabling Excellence in Food Retailing.



Available in 4', 6', 8' and 12' lengths.

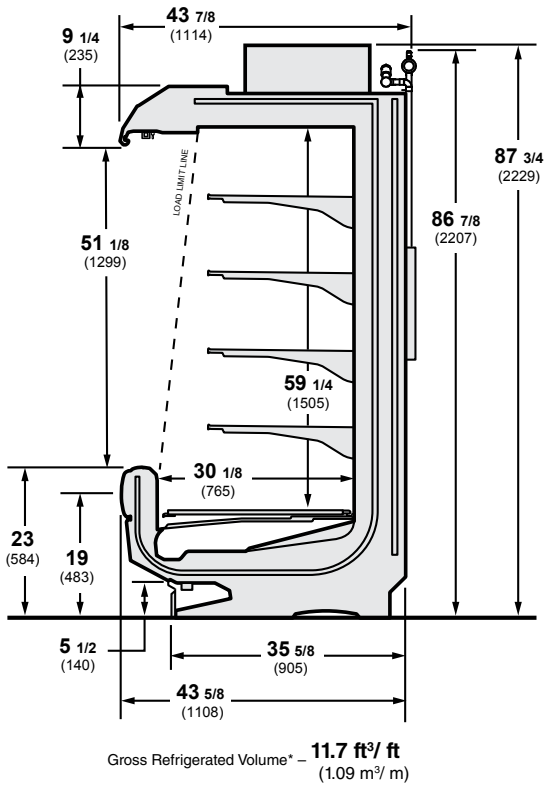

\*per ANSI/AHRI 1200-2013 appendix C, Volume Calculation



L21-20P



L21-30P



**Features / Benefits**

- ID5S cases are designed for effective multi-deck display of packaged dairy and deli products
- Merchandiser rejects heat through a continuous flow closed water-loop system at store level
- Water-loop system operates between 50 and 115°F inlet water temperatures
- Environmentally-friendly R290 hydrocarbon refrigerant that has zero ozone depletion (ODP) potential and 3 Global Warming Potential (GWP)
- Unibody construction improves integrity, facilitates moving, joining and settling cases
- UL, NSF Type I and DOE 2017 certified
- **Energy and Sustainability Benefits**
  - EcoShine II LED lights standard:
    - Up to 71% more efficient than fluorescents
    - Customized for optimal product lighting
    - Standard LED lights reduce relamping and other maintenance costs
  - More stable and uniform product temperatures to maintain freshness and shorter defrost cycles protect food integrity
  - Improved air curtain reduces "cold aisle" effect by 2-3° F
- **Superior Merchandising and Flexibility**
  - All electrical parts/connections in display area can be sprayed with water, rated IP67
  - New anti-clog drain strainer
  - Coil and plenum in back wall for easy-to-clean bottom
  - Seamless plastic "bathtub" bottom helps prevent leaks
  - Wiring raceway in canopy for easy access
  - Ellipse and faceted design options to align with store image
  - Convertible merchandising optionally available
  - EcoShine II LED lighting standard, customized for optimal product lighting

**Standard Features**

- Color Interior/Exterior: Black, Grey, White
- Exterior Sign Panel: None
- LED Lighting: Canopy, Shelves
- Number of display levels: 5
- Power Cord: 3 phase 20A/208V or 30A/208V, NEMA L21-20P, L21-30P
- Hardwired: No
- Insulation: Polyurethane Foam - CFC Free

**Optional Accessories**

- Various ends, lighting, shelves, racks, paint, and bumper colors
- Two basic styling options, ellipse and faceted, with mix and match alternatives
- Unique, high efficiency night curtains
- Flip-up bottom rack
- Sign-ready canopy fascia panel



Husmann refrigerated merchandisers configured for sale for use in the United States meet or surpass the requirements of the DOE 2017 energy efficiency standards.

NOTE: These merchandisers are designed for use in stores when temperature and humidity do not exceed 75°F (23.9°C) and 55% R.H.

NOTE: We reserve the right to change or revise specifications and product design in connection with any feature of our products. Such changes do not entitle the buyer to corresponding changes, improvements, additions, or replacements for equipment previously sold or shipped.

**Plan View**

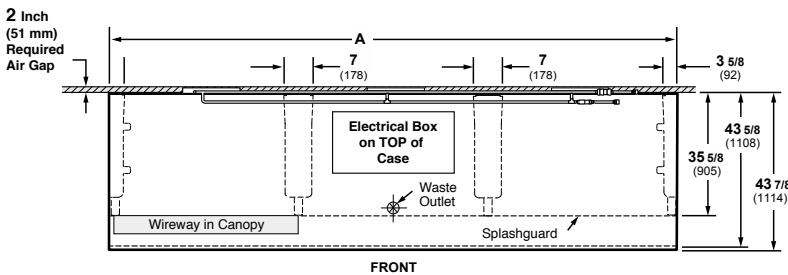

Dimensions	4 FT	6 FT	8 FT	12 FT
A	48 1/8 (1222)	72 1/4 (1835)	96 1/4 (2445)	144 3/8 (3668)

**Note: Overall case length without ends or partitions. Contact your sales representative for information on possible availability of additional case lengths.**

**Note**

Use Husmann's technical data sheets to get precise dimensions for all store layout purposes.

**Husmann Corporation**

12999 St. Charles Rock Rd.  
Bridgeton, MO 63044-2483  
Ph: 314.291.2000

[www.husmann.com](http://www.husmann.com)

