

**HUSSMANN®**

Insight® Merchandisers



# IDD5SU, IDD5SV

Insight 5-Deck Merchandisers  
with EcoVision Glass Doors and Ultra or Very Low Front  
for Dairy and Deli Applications

Two versatile styling options



CANOPY  
**Ellipse**

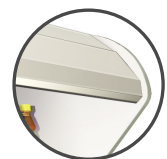

CANOPY  
**Faceted**

Enabling Excellence in Food Retailing.

# Hussmann Insight® 5-Deck Merchandisers with EcoVision Glass Doors and Ultra or Very Low Front for Dairy and Deli Applications

**IDD5SU** - Insight, Dairy, EcoVision Glass Doors, 5-Deck, Standard Front-to-Back Depth, Ultra Low Front

**IDD5SV** - Insight, Dairy, EcoVision Glass Doors, 5-Deck, Standard Front-to-Back Depth, Very Low Front

Available in 4', 6', 8' and 12' lengths.

## IDD5SU

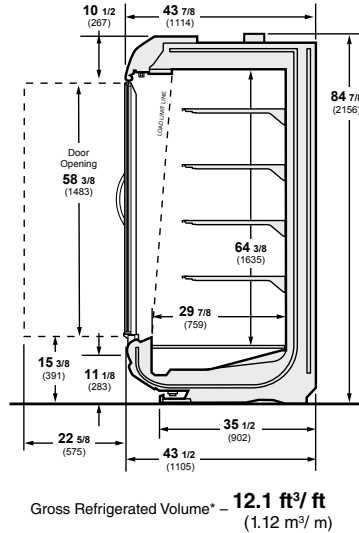

\*per ANSI/AHRI 1200-2013 appendix C, Volume Calculation

## IDD5SV

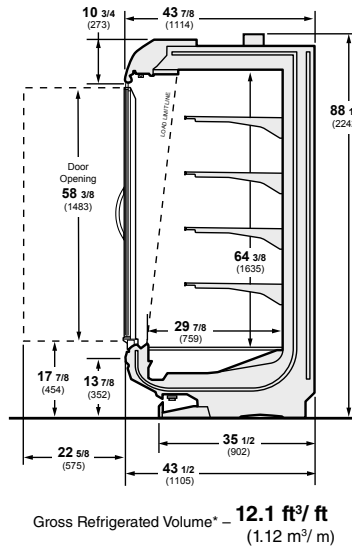

\*per ANSI/AHRI 1200-2013 appendix C, Volume Calculation

## Plan View

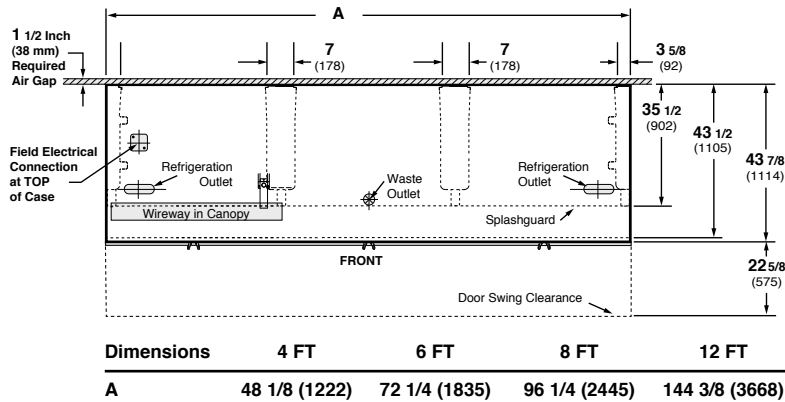

**Note: Overall case length without ends or partitions. Contact your sales representative for information on possible availability of additional case lengths.**

## Note

Use Hussmann's technical data sheets to get precise dimensions for all store layout purposes.

## Features / Benefits

- Hussmann IDD5SU and IDD5SV cases include EcoVision glass doors for superior merchandising appeal and optimal energy efficiency
- Extreme reliability. EcoVision glass doors are now tested for up to 99% reliability at 10 years
- Superior Food Quality
  - More stable and uniform product temperatures to maintain freshness
  - Shorter defrost cycles protect food integrity
- Energy and Sustainability Benefits
  - Insight cases with EcoVision glass doors save up to 20% energy versus previous Hussmann cases with doors, up to 75% energy than similar Insight dairy cases without doors, and up to 80% energy than previous Hussmann cases without doors
  - EcoShine II LED lights standard, up to 71% more efficient than fluorescents
  - Over 30% less refrigerant in coils vs. previous coil designs
- Better Structural Integrity
  - Unibody construction improves integrity, facilitates moving, joining, and setting cases
  - New joining system, gasket channel and other new features simplify installation
- Easier to Clean, Better Sanitation
  - Electrical parts/connections in splash zone can be sprayed with water, rated IP 67
  - New anti-clog drain strainer
  - Coil in back wall and flip-up fan plenums for easy-to-clean case bottom
  - Seamless plastic "bathtub" bottom helps prevent leaks
- Easier Service
  - Wiring raceway in canopy for easy access
  - Flip-up access door on optional bottom rack for easy access to drain, fans and valves
  - Standard LED lights reduce relamping and other maintenance costs
- Superior Merchandising
  - Ellipse and faceted design options to align with store image
  - EcoVision glass doors provide excellent product visibility and merchandising impact
  - Convertible merchandising optionally available
  - EcoShine II LED lighting standard, customized for optimal product lighting

## Options

- Various ends, lighting, shelves, racks, paint and bumper colors
- Two basic canopy styling options, ellipse and faceted, are available
- Flip-up bottom rack for easier cleaning/service
- EcoVision glass doors can be factory installed or field installed after purchase
- Sign-ready canopy fascia panel
- Options available on most models to adjust performance to Type II climatic conditions



Hussmann refrigerated merchandisers configured for sale for use in the United States meet or surpass the requirements of the DOE 2017 energy efficiency standards.

NOTE: These merchandisers are designed for use in stores when temperature and humidity do not exceed 75°F (23.9°C) and 55% R.H.

NOTE: We reserve the right to change or revise specifications and product design in connection with any feature of our products. Such changes do not entitle the buyer to corresponding changes, improvements, additions, or replacements for equipment previously sold or shipped.

**HUSSMANN®**

## Hussmann Corporation

12999 St. Charles Rock Rd.  
Bridgeton, MO 63044-2483  
Ph: 314.291.2000

[www.hussmann.com](http://www.hussmann.com)