

HUSSMANN®

Insight® Merchandisers



IP1XSL, IP1XXSL

Insight Single-Deck, Extra Height Merchandisers
with Low Front for Produce Applications

Two versatile styling options



BUMPER

Ellipse



BUMPER

Faceted

Enabling Excellence in Food Retailing.

Hussmann Insight® Single-Deck, Extra Height Merchandisers with Low Front for Produce Applications

IP1XSL - Insight, Produce, Single-Deck, Extra Tall (approx. 7" taller), Standard Depth, Low Front

IP1XXSL - Insight, Produce, Single-Deck, Extra-Extra Tall (approx. 11" taller), Standard Depth, Low Front

Available in 4', 6', 8' and 12' lengths.

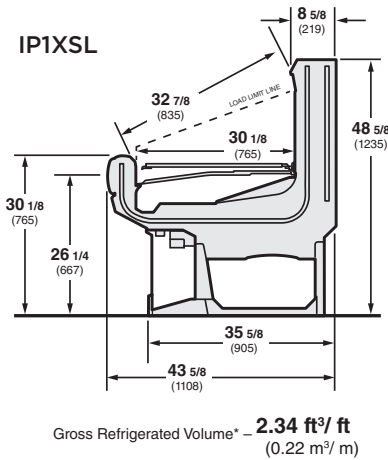

*per ANSI/AHRI 1200-2013 appendix C. Volume Calculation

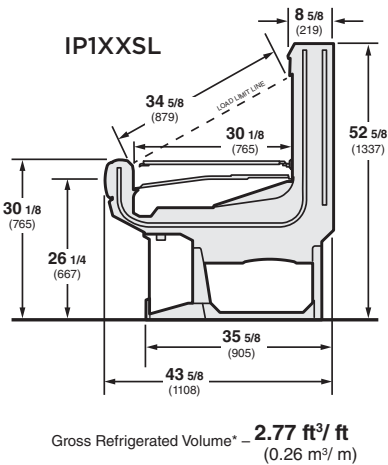

*per ANSI/AHRI 1200-2013 appendix C. Volume Calculation

Plan View

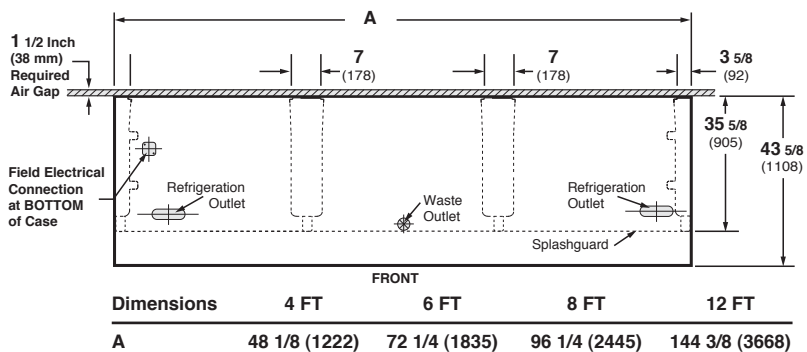

Note: Overall case length without ends or partitions. Contact your sales representative for information on possible availability of additional case lengths.

Note

Use Hussmann's technical data sheets to get precise dimensions for all store layout purposes.

Features / Benefits

- The IP1XSL and IP1XXSL can be used for single-deck displays to create an ideal platform for fresh produce
- These X and XX models allow more merchandising capacity and steeper display slant
- **Superior Food Quality**
 - More stable and uniform product temperatures to protect and maintain freshness
 - Shorter defrost cycles protect food integrity
- **Energy and Sustainability Benefits**
 - Superior energy efficiency vs. previous models
 - Over 30% less refrigerant in coils vs. previous coil designs
- **Better Structural Integrity**
 - Unibody construction improves integrity, facilitates moving, joining, and setting cases
 - Additional new features simplify installation
- **Easier to Clean, Better Sanitation**
 - Electrical parts/connections in display zone can be sprayed with water, rated IP 67
 - New anti-clog drain strainer
 - Coil in back wall and flip-up fan plenums make cleaning case bottom easy
 - Seamless plastic "bathtub" bottom helps prevent leaks
- **Easier Service**
 - Flip-up access door on optional bottom rack for easy access to drain, fans and valves
- **Superior Merchandising**
 - Ellipse and faceted design options to align with store image
 - Improved air curtain reduces "cold aisle" effect by 2-3° F

Options

- Various ends, racks, paint, and bumper colors
- Two basic styling options, ellipse and faceted, with mix and match alternatives
- Flip-up bottom rack
- Options available on most models to adjust performance to Type II climatic conditions



Hussmann refrigerated merchandisers configured for sale for use in the United States meet or surpass the requirements of the DOE 2017 energy efficiency standards.

NOTE: These merchandisers are designed for use in stores when temperature and humidity do not exceed 75°F (23.9°C) and 55% R.H.

NOTE: We reserve the right to change or revise specifications and product design in connection with any feature of our products. Such changes do not entitle the buyer to corresponding changes, improvements, additions, or replacements for equipment previously sold or shipped.

HUSSMANN®

Hussmann Corporation

12999 St. Charles Rock Rd.
Bridgeton, MO 63044-2483
Ph: 314.291.2000

www.hussmann.com