

HUSSMANN®

Insight® Merchandisers



IP4SLI90X

Insight 90° Inside Wedge, Extra Wide, for 4-Deck Merchandisers with Low Front for Produce Applications

Two versatile styling options



BUMPER

Ellipse



BUMPER

Faceted

Enabling Excellence in Food Retailing.

Husmann Insight 90° Inside Wedge, Extra Wide, for 4-Deck Merchandisers with Low Front for Produce Applications

IP4SLI90X - Insight, Produce, 4-Deck, Standard Front-to-Back Depth, Low Front, Inside 90° Wedge, Extra Wide

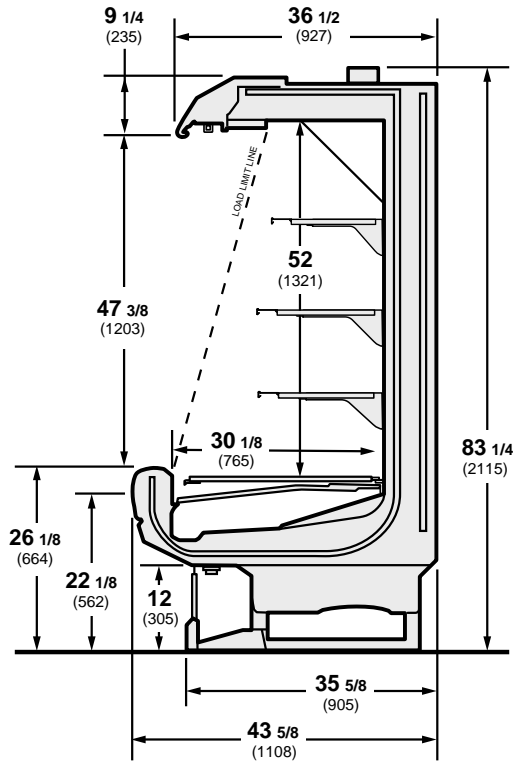

Gross Refrigerated Volume* - **34.52 ft³/ft**
(0.98 m³)

*AHRI Gross Refrigerated Volume: Refrigerated Volume, ft³/m³

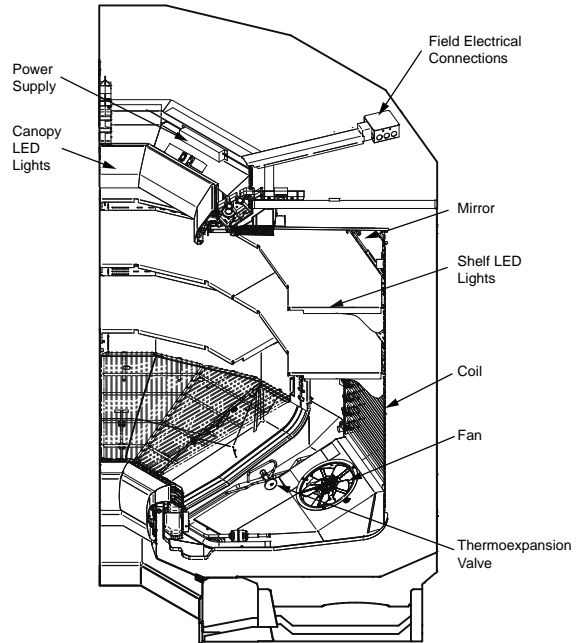

Plan View

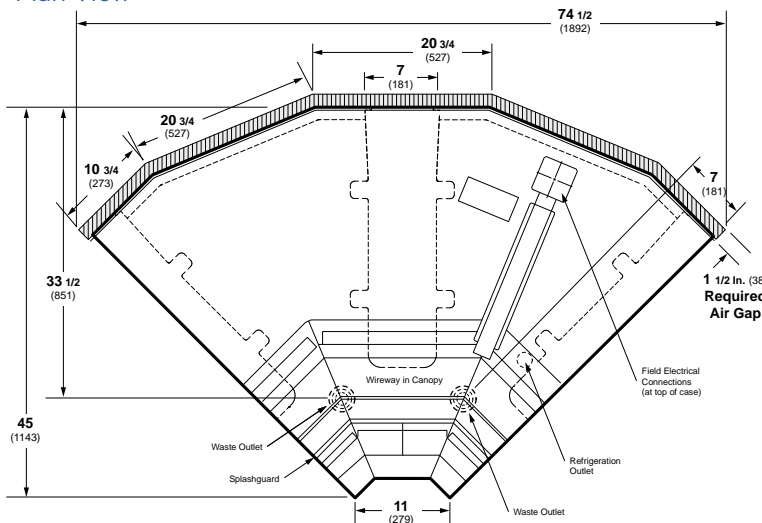

Note

Use Husmann's technical data sheets to get precise dimensions for all store layout purposes.

Features / Benefits

- 90° Inside Wedge can be used with IP4SL parent cases to create a 90° inward turn in a line-up
- DOE 2017 compliant energy performance
- Flexible shelf positions
- Additional Insight wedges may be available. Consult Husmann sales representative.

Options

- Various paint and bumper colors
- Various shelf sizes
- Optional shelf lighting



Husmann refrigerated merchandisers configured for sale for use in the United States meet or surpass the requirements of the DOE 2017 energy efficiency standards.

NOTE: These merchandisers are designed for use in stores when temperature and humidity do not exceed 75°F (23.9°C) and 55% R.H.

NOTE: We reserve the right to change or revise specifications and product design in connection with any feature of our products. Such changes do not entitle the buyer to corresponding changes, improvements, additions, or replacements for equipment previously sold or shipped.

HUSSMANN®

Husmann Corporation

12999 St. Charles Rock Rd.
Bridgeton, MO 63044-2483
Ph: 314.291.2000

www.husmann.com