



M4X-GE

---

# M4X-EP, M4X-GE, M4X-GEP

Excel Large Capacity Multi-Deck Meat  
Display Merchandiser

# Husmann Large Capacity Multi-Deck Display Merchandiser for Fresh Meat Applications

**M4X-EP** - Large Capacity Multi-Deck, Extra-High Efficiency

**M4X-GE** - Large Capacity Multi-Deck with Glass Front

**M4X-GEP** - Large Capacity Multi-Deck, Glass Front, Extra-High Efficiency

Available in 8' and 12' lengths. Contact your sales rep for information on possible availability of additional case lengths.

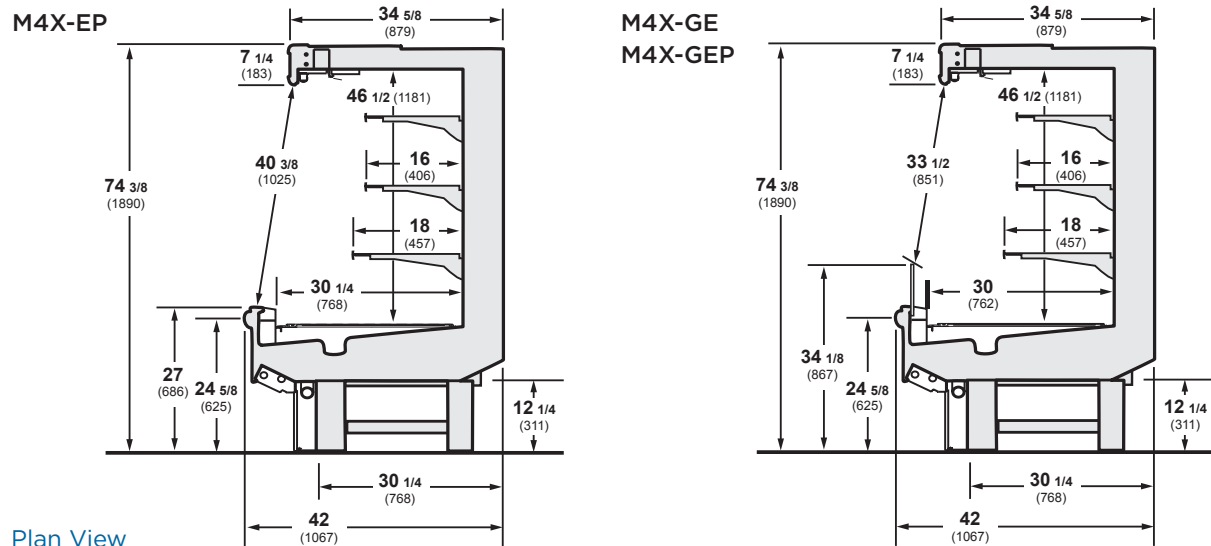

Plan View

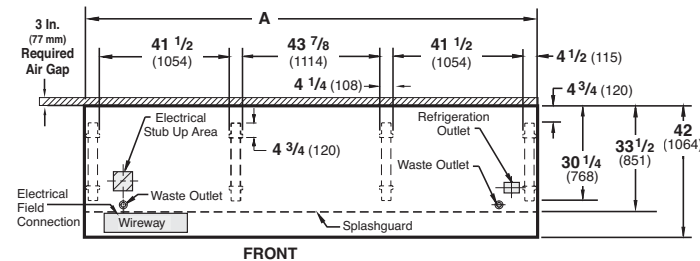

Dimension	8 FT	12 FT
A	96 3/8 (2448)	144 1/2 (3670)

Notes:  
Overall case length without ends or partitions.

## Note

Use Husmann's technical data sheets to get precise dimensions for all store layout purposes.

## Superior Merchandising.

The M4X is an easy-to-shop, large volume meat multi-deck. Glass front and rail light options improve product visibility. Other superior merchandising features include full vision glass ends, illuminated canopy signs, improved ledge lighting and greater shelf placement flexibility.

## Superior Shelf Life.

Modular coils and off-time defrost reduce thermal shock and stabilize meat temperatures.

## Lower Labor Costs.

Labor saving features include greater clearance under the case, easy-to-clean bathtub bottom, easier raceway access, 2-ft honeycomb sections and more.

## Superior Reliability.

Our 5 year modular coil warranty is the best available. Pre-set adjustable expansion valves are designed to hold optimal temperatures.

NOTE: These merchandisers are designed for use in stores when temperature and humidity do not exceed 75°F and 55% R.H.

NOTE: We reserve the right to change or revise specifications and product design in connection with any feature of our products. Such changes do not entitle the buyer to corresponding changes, improvements, additions, or replacements for equipment previously sold or shipped.

For additional resources, contact your representative or visit [www.husmann.com](http://www.husmann.com).

**DOE 2017 Energy Efficiency Compliant** Husmann refrigerated merchandisers configured for sale for use in the United States meet or surpass the requirements of the DOE 2017 energy efficiency standards.

**HUSSMANN®**

**Husmann Corporation**  
12999 St. Charles Rock Rd.  
Bridgeton, MO 63044-2483  
Ph: 314.291.2000

[www.husmann.com](http://www.husmann.com)