

MD4060DA

Self-Contained, Multi-Deck
Medium Temperature Merchandiser

Advanced Design.

- Glass ends for side visibility.
- Heavy-duty, anti-microbial door handles.

Merchandising with Style.

- Available with high efficiency LED vertical lighting for canopy.
- Easy access to display levels for merchandising or shopping.

Smart Construction.

- Easy to clean interior and exterior with clean-out drain.
- Easy to service slide out condensing unit.
- Timer controlled automatic defrost and thermometer.
- Product visibility is improved with 29-inch long vertical LED lighting for evenly illuminated merchandise throughout display area.

Innovative Refrigeration.

- Front air intake and discharge - requires a 1-inch min. open space behind the back of the case.
- State-of-the-art honeycomb discharge air system assures even temperature and maximum efficiency.
- Adjustable temperature control.
- Aluminum fins and tubes help minimize corrosion.
- 2" foamed in-place insulation with high density polyurethane insulation - zero ozone depletion potential.



Self-Contained, Multi-Deck Merchandiser for Beverage, Dairy, Deli, and Produce Applications

MD4060DA - Specialty Propane, Multi-Deck Med Temp Merchandiser

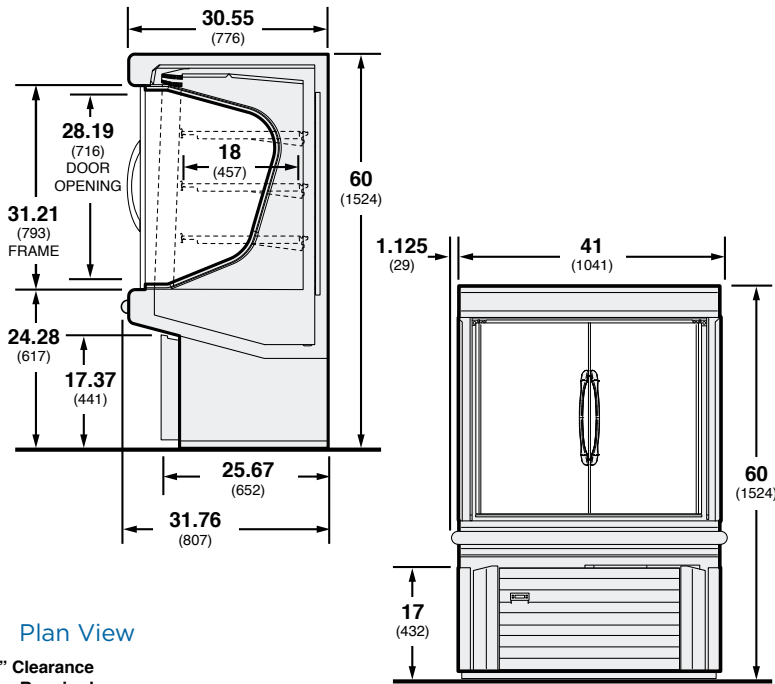

Plan View

1" Clearance
Required

MD4060DA



NEMA 5-15P

Standard Features.

- Color Exterior Black
- Color Interior Black
- Bumper Black
- Doors (2)
- Shelves (6) 18"
- LED Vertical Lighting Yes
- PTM Yes
- End Panels View
- Power Cord 9 ft
- Hardwired No
- NSF Type II
- Air Discharge Front
- Insulation CFC-Free
- Leg Levelers Yes
- Condensate Pan Removal

Optional Accessories.

- Additional shelving.
- Stainless steel exterior or choice of exterior colors.
- Wrap-around bumper.
- Side bumpers (specify color).
- Leg and caster kits, cross bar and hook display.

Specifications

Model	Exterior Dimensions			Nom. HP	Refrig.	Hz/Ph	Electrical			NEMA Plug	Refrig.* Load (BTU/h)	Energy Consumption (Kwh/day)	A/C Load (BTU/h)	Approx. Ship Wt. (lbs)
	L	D	H				Run Amps	Fuse Amps	Volts					
MD4060DA	41-5/16"	30-7/16"	60-1/4"	1/4	R-290	60/1	115	1.83	15	5-15P	2399	2.18	3325	434

* Refrigeration load calculated at 20° F evaporation and 110° F condensing temperature.

NOTE: These merchandisers are designed for use in stores when temperature and humidity do not exceed 80°F and 55% R.H. Case is designed for holding pre-frozen product only.

NOTE: We reserve the right to change or revise specifications and product design in connection with any feature of our products. Such changes do not entitle the buyer to corresponding changes, improvements, additions, or replacements for equipment previously sold or shipped.

For additional resources and warranties, contact your representative or visit www.hussmann.com.



Hussmann refrigerated merchandisers configured for sale for use in the United States meet or surpass the requirements of the DOE 2017 energy efficiency standards.



HUSSMANN®

Hussmann Corporation
12999 St. Charles Rock Rd.
Bridgeton, MO 63044-2483
Ph: 314.291.2000

www.hussmann.com