

HUSSMANN®

Impact™ Merchandisers



RFLNI

Impact Freedom Line Reach-In
Back-to-Back Narrow Merchandiser
for Frozen Food Applications

www.husmann.com

Hussmann Impact Freedom Line Reach-In Back-to-Back Narrow Merchandiser for Frozen Food Applications

RFLNI - Back-to-Back Reach-In, Freedom Line, Narrow Footprint

Available with 4 and 5 doors.

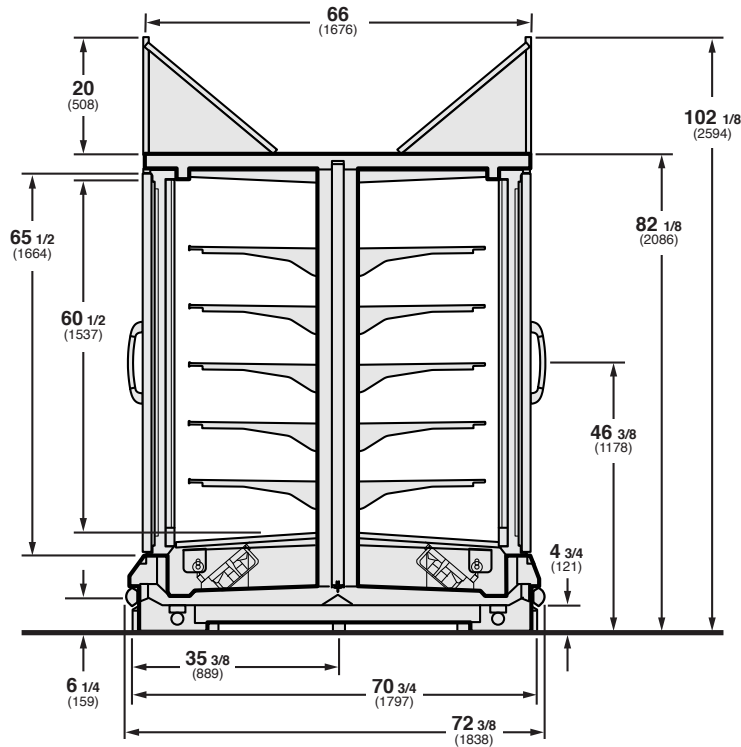

Plan View

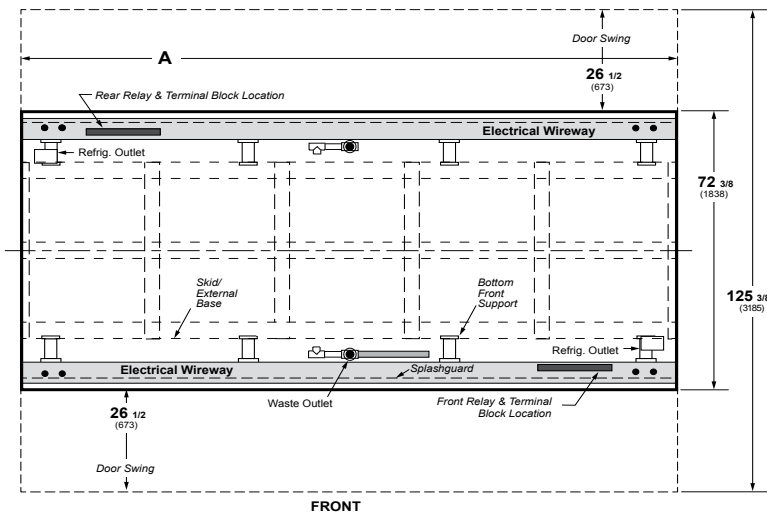

Dimensions	4 DOOR	5 DOOR
A	122 7/8 (3121)	153 3/8 (3896)

Note: Overall case length without ends or partitions. Contact your sales representative for information on possible availability of additional case lengths.

Note

Use Hussmann's technical data sheets to get precise dimensions for all store layout purposes.

Features and Benefits

- Freedom Line cases provide the flexibility of field-installed refrigeration on top of case or from a remote location
- RFLNI reduces the footprint by 16 inches from back-to-back standard reach-in cases
- High pack-out in limited footprint allowing more product in same space
- Suitable for heavy shopping environments
- Superior energy efficiency
- Excellent product temperature consistency throughout the refrigerated space

Options Include

- Various shelves, racks, lighting, paint, and bumper colors.
- Innovator, Innovator I LE, and Innovator III doors available.
- Top-mounted or remote refrigeration.
- Canopy and condensing unit are field installed.



Hussmann refrigerated merchandisers configured for sale for use in the United States meet or surpass the requirements of the DOE 2017 energy efficiency standards.

NOTE: These merchandisers are designed for use in stores when temperature and humidity do not exceed 75°F and 55% R.H.

NOTE: We reserve the right to change or revise specifications and product design in connection with any feature of our products. Such changes do not entitle the buyer to corresponding changes, improvements, additions, or replacements for equipment previously sold or shipped.

For additional resources, contact your representative or visit www.hussmann.com.

HUSSMANN®

Hussmann Corporation
12999 St. Charles Rock Rd.
Bridgeton, MO 63044-2483
Ph: 314.291.2000

www.hussmann.com