



# EGPF-MT

## eGROCERY FREEDOM MERCHANDISER



### ADVANTAGES

- Increased height for high volume tote staging
- Ideal for any medium temperature product staging
- Frameless French style doors provide ease of product access
- Top electric and refrigeration piping for easy installation
- Service-friendly construction for quick access



### KEY POINTS

- Available with 54 tote capacity
- Freedom Line gives the flexibility of field installed refrigeration on top of the case or from a remote location
- Meets Type 2 ambient conditions and current NSF/ANSI standards



# EGPF-MT eGrocery Freedom Merchandiser

## MERCHANDISING

- Freedom Line refrigeration options include field intalled top condensing unit or piping to a remote system
- No drains required
- Frameless French style doors
- Six display levels for 54 totes

## SERVICEABILITY

- Standard electrical connections on top for ease of service
- Electrical compartment can be moved to any location at the time of installation to help with future service

## ENERGY PERFORMANCE

- AHRI 1200 rating point for energy consumption

## STORE CONDITIONS

- NSF Type I and Type 2 Certified
- Intertek and UL Listed
- DOE 2017 Certified

## OPTIONS

- Optional Hussmann provided condensing unit for air-cooled applications
- Optional condensate evaporator pan heater
- Color Options: Standard Colors (Black/White)

## TECHNICAL INFORMATION



Scan the QR code with your mobile device to access technical data sheet on [hussmann.com](http://hussmann.com)

Case available with 54 tote capacity.

### STANDARD CURRENT TOTE SIZE

Length:	23.62"
Width:	15.75"
Total Height:	11.31"

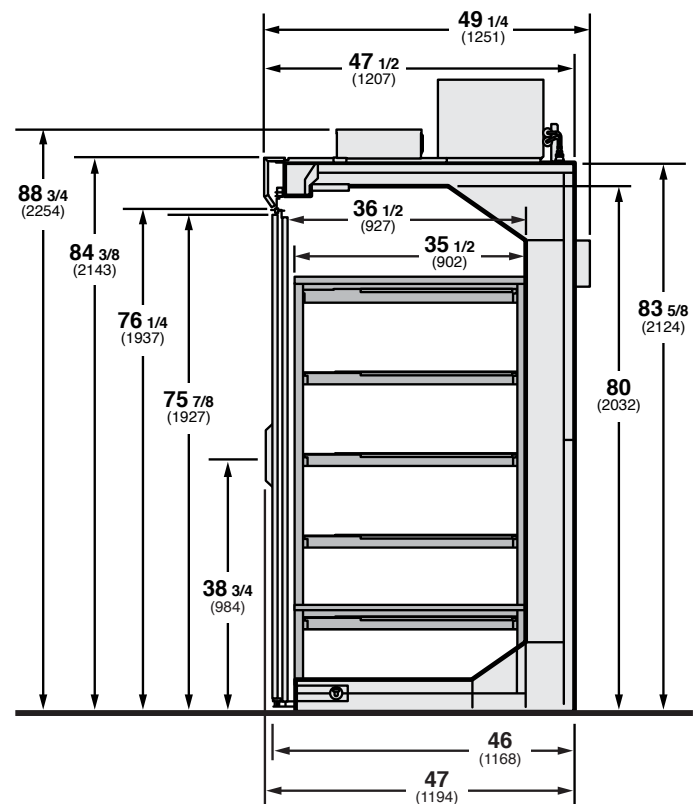

**DOE 2017 Energy Efficiency Compliant** Hussmann refrigerated merchandisers configured for sale for use in the United States meet or surpass the requirements of the DOE 2017 energy efficiency standards.

NOTE: These merchandisers are designed for use in stores when temperature and humidity do not exceed 80°F and 55% R.H. We reserve the right to change or revise specifications and product design in connection with any feature of our products. Such changes do not entitle the buyer to corresponding changes, improvements, additions, or replacements for equipment previously sold or shipped. For additional resources, contact your representative or visit [www.hussmann.com](http://www.hussmann.com).



**Hussmann Corporation**  
12999 St. Charles Rock Rd.  
Bridgeton, MO 63044-2483  
Ph: 800.592.2060

[www.hussmann.com](http://www.hussmann.com)