

IC4SLO90X

90° OUTSIDE WEDGE MERCHANDISER



ADVANTAGES

- High volume multi-deck designed to display dairy, deli, and beverage applications
- Energy and sustainability benefits
- Better structural integrity
- Easier to service
- Superior merchandising



KEY POINTS

- Extra wide convertible 4-deck merchandiser
- Low front
- DOE compliant energy performance
- Flexible shelf positions



IC4SLO90X Insight® 90° Outside Wedge

MERCHANDISING

- 90° Outside Wedge can be used with IC4SL parent cases to create a 90° outward turn in a line-up
- Additional Insight wedges may be available. Consult Hussmann sales representative.

STORE CONDITIONS

- NSF / ANSI Certified
- Intertek ETL Listed

OPTIONS

- Optional shelf lighting
- Various shelf sizes and bumper options
- Several paint and bumper colors available

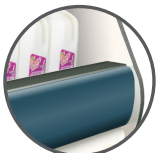

BUMPER
Ellipse



BUMPER
Faceted



Hussmann refrigerated merchandisers configured for sale for use in the United States meet or surpass the requirements of the DOE 2017 energy efficiency standards.

NOTE: These merchandisers are designed for use in stores when temperature and humidity do not exceed 75°F and 55% R.H.

We reserve the right to change or revise specifications and product design in connection with any feature of our products. Such changes do not entitle the buyer to corresponding changes, improvements, additions, or replacements for equipment previously sold or shipped.

For additional resources, contact your representative or visit www.hussmann.com.

TECHNICAL INFORMATION



Scan the QR code with your mobile device to access technical data sheet on hussmann.com

IC4SLO90X

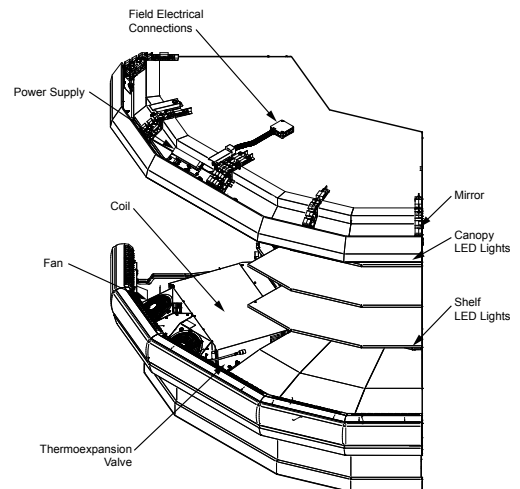
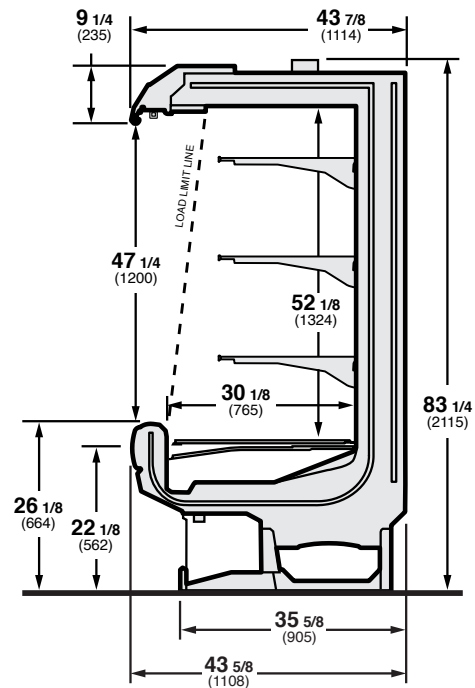

HUSSMANN®

Hussmann Corporation
12999 St. Charles Rock Rd.
Bridgeton, MO 63044-2483
Ph: 800.592.2060

www.hussmann.com