



FIG

---

# FI, FIG

Excel Intermediate Island Merchandiser  
with/without Glass Front

# Hussmann Excel Intermediate Island Merchandiser for Frozen Food Applications

## FI - Intermediate Island

Available in 6', 8', and 12' lengths\*. Contact your sales rep for information on possible availability of additional case lengths.

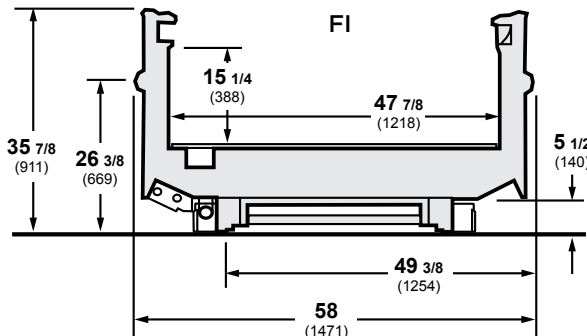

## FIG - Intermediate Island with Glass

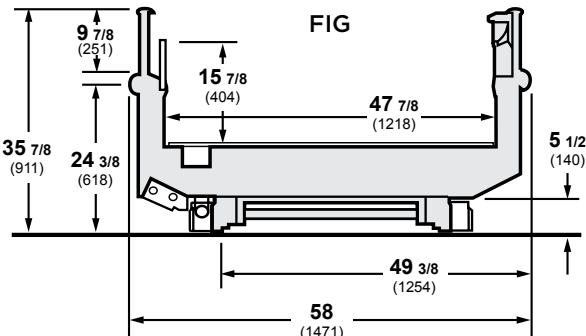

## Plan View

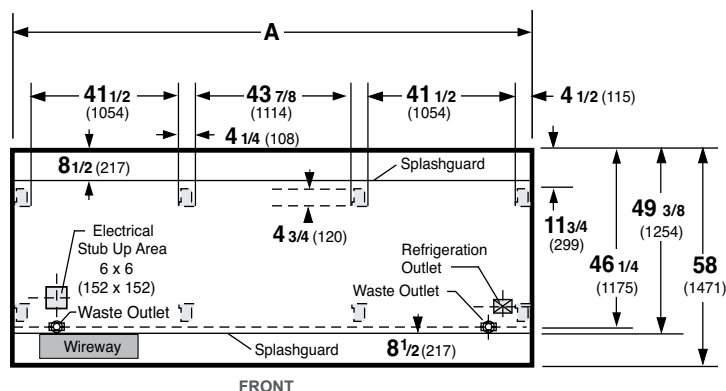

### Dimensions: A

6 FT	8 FT	12 FT
73 3/4 (1872)	96 3/8 (2448)	144 1/2 (3670)

**Notes: Overall case length without ends or partitions. Contact your sales representative for information on possible availability of additional case lengths.**

## Note

Use Hussmann's technical data sheets to get precise dimensions for all store layout purposes.

## More Energy Efficient

The Excel FI and FIG models provide superior energy efficiency compared to Impact and competitive models.

## 13% to 16% More Merchandising Space

Compared with the standard Impact models, the Excel FI provides 13% more merchandising space and FIG provides a full 16% additional merchandising capacity.

## Superior Shelf Life

Excellent temperature consistency and stability throughout the display zone due to Hussmann's proprietary discharge air louvers and continuous tube serpentine coils.

## Lower Labor Costs

Labor saving features include greater clearance under the case, easier raceway access and simplified wiring.

## Superior Reliability

Our five year coil warranty is the best available. Pre-set adjustable expansion valves are designed to hold optimal temperatures.

## Sliding Glass Lids Available

Sliding glass lids are available as a field installed upgrade or as original equipment for all single deck, open island display cases. Lids will reduce overall case energy from 40% to 60%, depending on case model.



Hussmann refrigerated merchandisers configured for sale for use in the United States meet or surpass the requirements of the DOE 2017 energy efficiency standards.

NOTE: These merchandisers are designed for use in stores when temperature and humidity do not exceed 75°F and 55% R.H.

NOTE: We reserve the right to change or revise specifications and product design in connection with any feature of our products. Such changes do not entitle the buyer to corresponding changes, improvements, additions, or replacements for equipment previously sold or shipped.

For additional resources, contact your representative or visit [www.hussmann.com](http://www.hussmann.com).

# HUSSMANN®

Hussmann Corporation  
12999 St. Charles Rock Rd.  
Bridgeton, MO 63044-2483  
Ph: 314.291.2000

[www.hussmann.com](http://www.hussmann.com)

MK\_0000386\_C\_PS\_FI\_FIG\_EN