

VRL-B1A

SELF-CONTAINED MERCHANDISER



ADVANTAGES

The natural refrigerant case solution!

- Environmentally-friendly R-290 natural refrigerant
- Refrigeration system capable of maintaining -10°F temperature
- Evaporator and condenser fan motors produces less heat, reduces energy consumption and provides greater reliability



KEY FEATURES

- Self-service reach-in with doors
- 120V plug-n-play design for fast deployment
- Bottom mount condensing unit
- Customizable top lighted display
- 1-, 2- and 3-glass door models available



VRL-B1A

STANDARD CONFIGURATION

- Color Exterior: Black, White
- Color Interior: Black, White
- Exterior Sign Panel: Lighted Flat Panel
- View End Panels: No
- Shelves: 4 Shelves
- LED Lighting: Yes (Vertical)
- Adjustable Leveling Legs: Yes
- Refrigerant: R-290
- Power Cord: Yes, 9ft
- Power Supply: 120V / 1ph / 60Hz
- NEMA Plug: 5-15
- NSF Certification: Type II
- Air Discharge: Front
- Defrost: Hot Gas

OPTIONS

- Stainless steel exterior/interior
- Adjustable leveling legs
- Baskets, peg bar and hooks
- Additional display shelves available
- Price tag molding
- Door locks and shelf product stops
- Customizable sign kit available
- Left door opening is standard; right door opening is optional

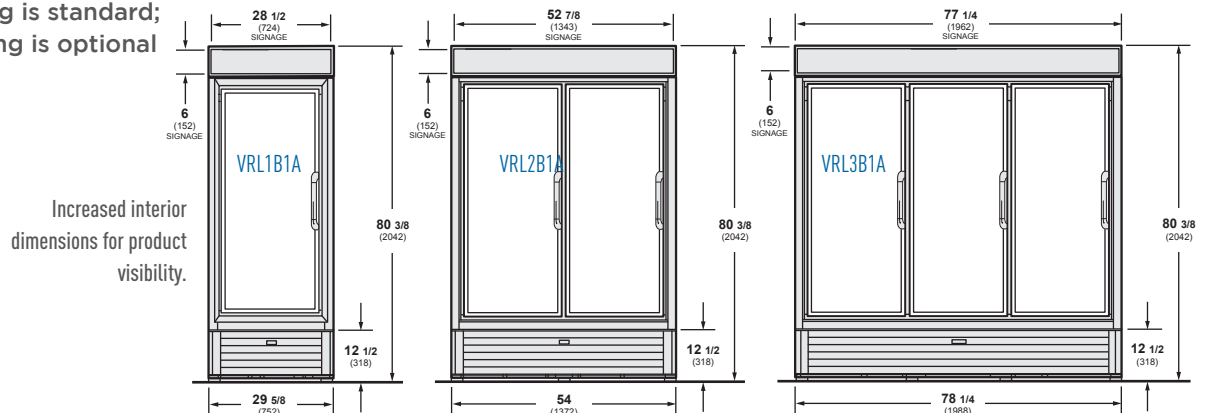

TECHNICAL INFORMATION



Scan the QR code with your mobile device to access technical data sheet on hussmann.com

Available in 1-, 2-, and 3-Glass Door models.

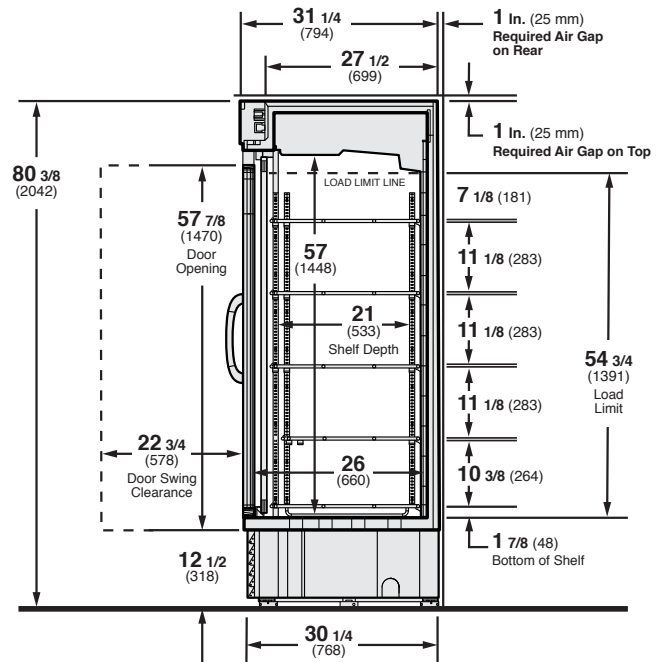

We reserve the right to change or revise specifications and product design in connection with any feature of our products. Such changes do not entitle the buyer to corresponding changes, improvements, additions, or replacements for equipment previously sold or shipped. For additional resources, contact your representative or visit www.hussmann.com.

HUSSMANN®

Hussmann Corporation
12999 St. Charles Rock Rd.
Bridgeton, MO 63044-2483
Ph: 800.592.2060

www.hussmann.com

MK_0000412_C_PS_VRL-B1A_EN