

HUSSMANN®



SMGB

Excel Self-Contained Service Merchandiser
with Curved Glass and Gravity Coil
for Medium Temperature Applications

- NSF Certified

www.hussmann.com

Husmann Excel Self-Contained Service Merchandiser with Curved Glass and Gravity Coil for Medium Temperature Applications

SMGB - Self-Contained, Single-Pane Curved Glass Case with Gravity Coil and Small Blower Coil

Available in 8' length only. Contact your sales rep for information on possible availability of additional case lengths.

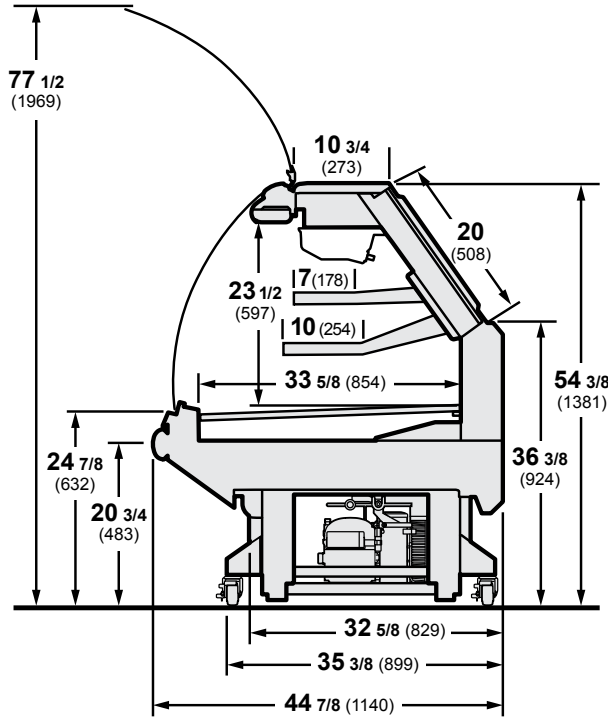

Plan View

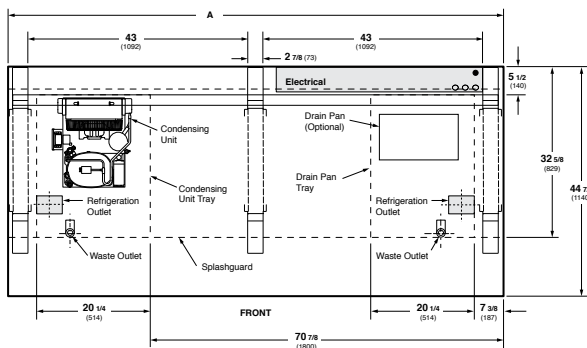

Dimensions	8 FT
A	99 1/4 (2521)

Note: Overall case length without ends or partitions.

Note

Use Husmann's technical data sheets to get precise dimensions for all store layout purposes.

Advanced Design

This case model incorporate advanced features and benefits, including modular coils, superior energy efficiency, modular case design, durable bumper, factory pre-adjusted expansion valves, and seamless polystyrene "bathtub" bottoms for quick, easy cleaning. Both are self-contained for plug and play operation.

Reduced Refrigerant, Fewer Leaks

Patented Husmann modular coils require 50% to 60% less refrigerant. Also, all return bend solder joints have been eliminated, which greatly reduces the possibility of refrigerant leaks.

Merchandising with Style

One look tells the story. Sleeker, cleaner exterior to enhance product display. Attractive molded end design. Excellent lighting and product visibility for "high impact" merchandising that sells.

Easy to Work

Front glass tilts up for easy stocking and cleaning. 10 1/2" stainless flat non-movable top is standard. A large 20" rear door opening has an increased angle to improve reach and ergonomics. Options include mezzanine shelves, display racks, scale stands, thermometers, and wrapping boards.

NSF Certified

Both models have been NSF Certified to ANSI/NSF standard 7.

DOE 2017 Energy Efficiency Compliant Husmann refrigerated merchandisers configured for sale for use in the United States meet or surpass the requirements of the DOE 2017 energy efficiency standards.

NOTE: This merchandiser is designed for use in stores when temperature and humidity do not exceed 75°F and 55% R.H.

NOTE: We reserve the right to change or revise specifications and product design in connection with any feature of our products. Such changes do not entitle the buyer to corresponding changes, improvements, additions, or replacements for equipment previously sold or shipped.

For additional resources, contact your representative or visit www.husmann.com.

HUSSMANN®

Husmann Corporation
12999 St. Charles Rock Rd.
Bridgeton, MO 63044-2483
Ph: 314.291.2000

www.husmann.com