



IRL, IRM, IRLN, IRMN

INSIGHT REACH-IN MERCHANDISERS



ADVANTAGES

- Designed for maximum energy savings, refrigeration performance, and merchandising impact
- Industry leading door design for more product visibility and substantial energy savings
- Improved serviceability with easy-to-access refrigeration components
- Internal redesign creates extra pack out with efficient airflow



KEY POINTS

- Anti-fog film allows for No-Heat doors and reduced energy usage
- Doors are reversible
- Easy access to top electrical raceway
- Deck pan designed for easy access to refrigeration components
- Modular fan plenum design



IRL, IRM, IRLN, IRMN Insight® Reach-In Merchandisers

MERCHANDISING

- Designed for any low or medium temperature product
- Slimmer mullions and door handles with redesigned lighting improves product visibility
- Internal redesign increases merchandise pack out
- Allows up to 27" shelves

TESTING STANDARDS

- NSF / ANSI Certified
- Intertek ETL Listed
- DOE 2017 Certified

OPTIONS

- Available in low temp and medium temperature
- Available in narrow and standard depth
- Available with CO2 and DX refrigerants
- Available with left and right hand door configuration
- 18", 20", 22", 24" shelves for narrow case model
- 20", 24", 27" shelves for standard case model
- Various kits for customization (shelves, racks, lighting, paint, and bumper colors)

DIMENSIONS

Model	IRL / IRM	IRLN / IRMN
LENGTH		
2 Door	61 3/4" (1568)	61 3/4" (1568)
3 Door	92 1/8" (2334)	92 1/8" (2334)
4 Door	122 5/8" (3115)	122 5/8" (3115)
5 Door	153 3/8" (3896)	153 3/8" (3896)
DEPTH	44" (1118)	39" (991)
HEIGHT	85 3/8" (2169)	85 3/8" (2169)

TECHNICAL INFORMATION



Scan the QR code with your mobile device to access technical data sheet on hussmann.com

Available with 2, 3, 4, and 5 doors.

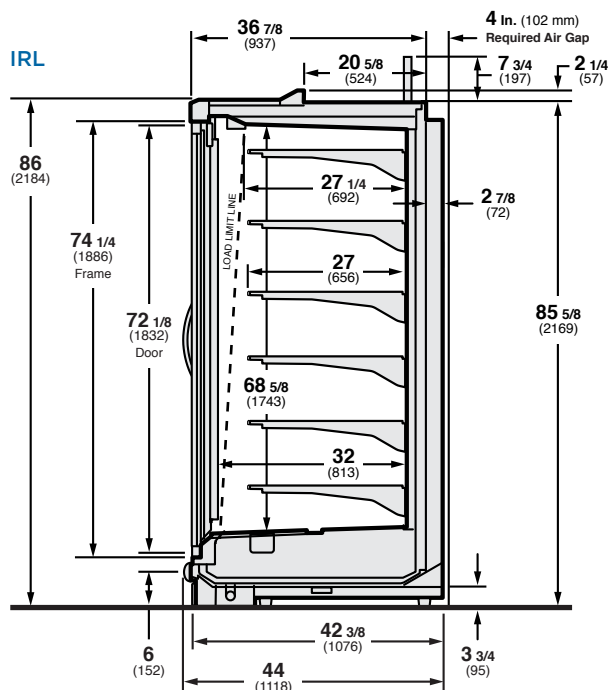

NOTE: These merchandisers are designed for use in stores when temperature and humidity do not exceed 75°F and 55% R.H. We reserve the right to change or revise specifications and product design in connection with any feature of our products. Such changes do not entitle the buyer to corresponding changes, improvements, additions, or replacements for equipment previously sold or shipped. For additional resources, contact your representative or visit www.hussmann.com.



Hussmann Corporation
12999 St. Charles Rock Rd.
Bridgeton, MO 63044-2483
Ph: 800.592.2060

www.hussmann.com