



P1X-E

---

# P1X-E, P1X-XE, P1NX-E

Excel Single-Deck  
Produce Merchandiser

# Husmann Excel Single-Deck Merchandiser for Produce Applications

## PIX-E - Single-Deck

## PIX-XE - Single-Deck with High Back

## PINX-E - Single-Deck, Narrow Footprint

Available in 8' and 12' lengths. Contact your sales rep for information on possible availability of additional case lengths.

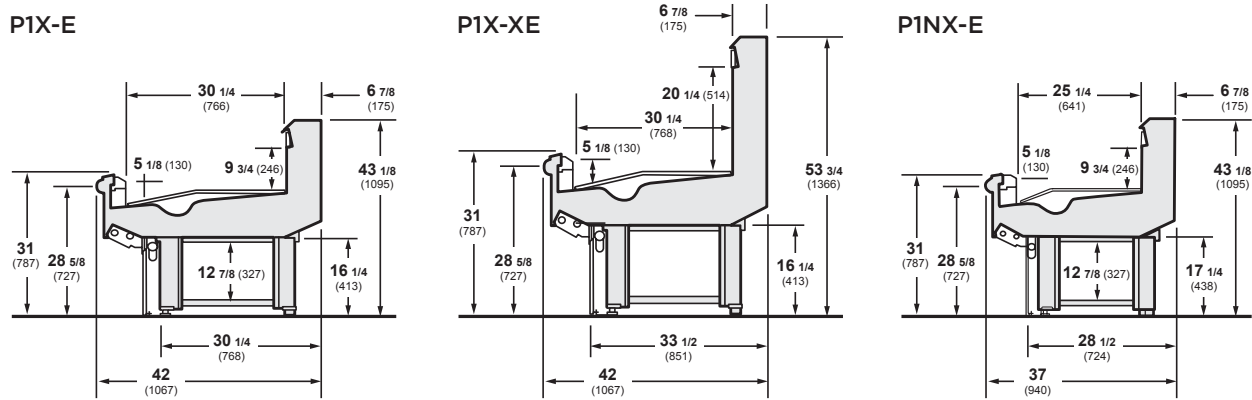

## Plan Views

### PIX-E, PIX-XE

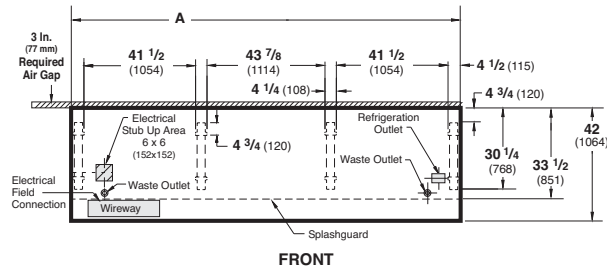

Dimension	8 FT	12 FT
A	96 3/8 (2448)	144 1/2 (3670)

#### Notes:

Overall case length without ends or partitions.

### PINX-E

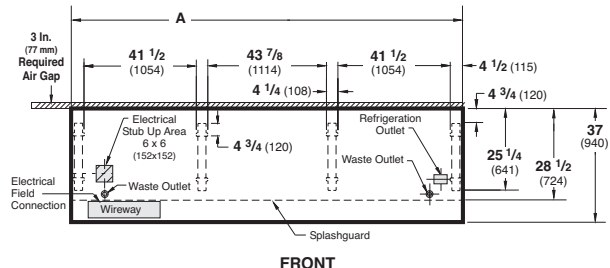

Dimension	8 FT	12 FT
A	96 3/8 (2448)	144 1/2 (3670)

#### Notes:

Overall case length without ends or partitions.

## Note

Use Husmann's technical data sheets to get precise dimensions for all store layout purposes.

## Superior Merchandising.

The PIX-E is a single deck display that makes your produce easy to see and easy to reach. The PIX-XE provides a higher back for more capacity, and the PINX-E reduces the front to back dimension to save floor space.

## Lower Energy Costs.

Energy efficient "E" coils are standard on the PIX-E.

## Superior Shelf Life.

Modular coils and off-time defrost work to reduce thermal shock and stabilize product temperatures.

## Lower Labor Costs.

Labor saving features include greater clearance under the case, easy-to-clean bathtub bottom, easier raceway access and more.

## Superior Reliability.

Our five year modular coil warranty is the best available. Pre-set adjustable expansion valves are designed to hold optimal temperatures.



NOTE: These merchandisers are designed for use in stores when temperature and humidity do not exceed 75°F and 55% R.H.

NOTE: We reserve the right to change or revise specifications and product design in connection with any feature of our products. Such changes do not entitle the buyer to corresponding changes, improvements, additions, or replacements for equipment previously sold or shipped.

For additional resources, contact your representative or visit [www.husmann.com](http://www.husmann.com).

# HUSMANN®

Husmann Corporation  
12999 St. Charles Rock Rd.  
Bridgeton, MO 63044-2483  
Ph: 314.291.2000

[www.husmann.com](http://www.husmann.com)